

Invitation For Bids

DEPARTMENT OF WATER, COUNTY OF KAUA‘I  
Job No. 17-10, WP2020 Project No. KW-07  
Rehabilitate Paua Valley Tank No. 1, 0.5 MG Concrete  
Kekaha Water System  
Kekaha, Kaua‘i, Hawai‘i

Pursuant to Chapter 103D, HRS, SEALED TENDERS will be received up to and opened at 2:00p.m., Hawaiian Standard Time (HST) on Thursday, October 31, 2019, in the Administration Office of the Department of Water at 4398 Pua Loke Street, Līhu‘e, Kaua‘i, Hawai‘i (“DOW Admin. Office”). Bids received after the date and time specified above shall be rejected. Facsimile offers will not be accepted or considered. Bids must be submitted via [www.publicpurchase.com](http://www.publicpurchase.com).

The schedule set out below represents the Department’s best estimate of the schedule that will be followed for this competitive sealed bidding procurement process. If an activity in the schedule is delayed, the dates following the delayed activity may be adjusted by the same number of days. All prospective Offerors will be advised by addendum of any changes to the Procurement Schedule.

Activity	Scheduled Date
Invitation For Bids Issued	September 23, 2019
Pre-Bid Conference	October 1, 2019 @ 8:30 AM HST
Deadline: Receipt of Questions / Comments / Material Substitutions	October 11, 2019
Deadline: Notice of Intent	October 21, 2019
Department’s Responses to Questions / Comments / Material Substitutions	October 21, 2019
Bid Opening	October 31, 2019
Selection / Award Notification	November 2019
Contract Execution Period	November 2019-December 2019
Contract Tentative Notice to Proceed Date	January 2020

The Manager and Chief Engineer also reserves the right to reject any or all bids, in whole or in part, if deemed to be in the best interest of the Department of Water.

Bids must be signed in ink by the person or persons duly authorized to sign bids in the space provided for signature on the Offer form.

**BIDDERS ARE HEREBY NOTIFIED THAT EVIDENCE OF THE AUTHORITY OF THE PERSON(S) SIGNING THE BID DOCUMENT IS REQUIRED TO BE INCLUDED WITH THE BID DOCUMENTS. FAILURE TO COMPLY WITH THIS REQUIREMENT WILL BE CAUSE FOR REJECTION OF THE BID AS BEING NON-RESPONSIVE.**

**SCOPE OF WORK:** The 0.5 MG PAUA VALLEY TANK #1 is a 0.5 million gallon (MG) reinforced concrete reservoir, with an inside diameter of 69 feet and a maximum water height of 18 feet to the overflow pipe opening. The flat concrete roof is supported on the interior by four square concrete columns. Work includes installation of a level indicator system with gauge board, remove and replace the interior ladder, remove and replace the asphalt concrete pavement surrounding the reservoir, repair the leak at the base of the reservoir, spall repairs, install interior coating of the reservoir, repaint the entire reservoir including appurtenances, remove and replace the reservoir roofing system, mitigate hazardous materials associated with the repair work. The Project is located in the Kekaha, Kaua‘i, Hawai‘i area accessed by a gated unpaved access road from Kokee Road., as indicated in the contract drawings and specifications.

**PLANS AND SPECIFICATIONS:** The contract documents are to be downloaded electronically. Please email the Department of Water Departmental Contracts Officer, Christine Erorita at [cerorita@kauaiwater.org](mailto:cerorita@kauaiwater.org) for instructions. May be examined and obtained at the DOW Admin. Office. Those who download documents electronically shall be responsible for any and all costs related to printing or reproducing the items as required for offer submission. For inquires on obtaining plans and specifications and all other inquires call the project engineer at (808) 245-5459.

The contract documents may be examined at the following locations:

DOW Admin. Office, Līhu‘e, Kaua‘i, Hawai‘i  
Building Industry Digest Plan Room, Honolulu, Hawai‘i  
General Contractors’ Association Plan Room, Honolulu, Hawai‘i

Published in:  Garden Island Newspaper  
 Bid Service Weekly  
 General Contractors’ Association  
 State Procurement Internet website at: <https://hands.ehawaii.gov/hands/welcome>  
 PublicPurchase website at: [www.publicpurchase.com](http://www.publicpurchase.com)  
 DOW website at: [www.kauaiwater.org](http://www.kauaiwater.org)

**CONTRACTORS LICENSE**: All prospective Bidders must be currently licensed by the State of Hawai‘i, Department of Commerce and Consumer Affairs, Division of Professional and Vocational Licensing.

“A” general engineering contractors and “B” general building contractors are reminded that due to the Hawai‘i Supreme Court’s January 28, 2002 decision in Okada Trucking Co., Ltd. v. Board of Water Supply, et al, 97 Haw. 450 (2002), they are prohibited from undertaking any work, solely or as part of a larger project, which would require the general contractor to act as a specialty contractor in any area where the general contractor has no license. Although the “A” and “B” contractor may still bid on and act as the “prime” contractor on an “A” or “B” project (See, HRS § 444-7 for the definitions of an “A” or “B” project), respectively, the “A” and “B” contractor may only perform work in the areas in which they have the appropriate contractor’s license (An “A” or “B” contractor obtains “C” specialty contractor’s licenses either on its own or automatically under HAR § 16-77-32.). The remaining work must be performed by appropriately licensed entities. It is the sole responsibility of the contractor to review the requirements of this Project and determine the appropriate licenses that are required to complete the Project.

**PRE-BID CONFERENCE**: The estimated contract value is more than \$500,000 and, thus, a Pre-Bid Conference shall be held. If a Pre-Bid Conference is held, all potential interested offerors, subcontractors, and union representatives are invited to attend on the date specified in the Procurement Schedule in Section 1.1 at the DOW Admin. Office. A visit to the site will be conducted following the meeting. The site inspection is not mandatory; however, submission of an offer shall be evidence that the Offeror understands the scope of the project and shall comply with the specifications herein, if awarded the contract and has thoroughly familiarize itself with the existing conditions, rules and regulations, and the extent and nature of work to be performed. No additional compensation, subsequent to bid opening, shall be allowed by reason of any misunderstanding or error regarding site conditions or work to be performed. All prospective Bidders must make their own transportation arrangements to and from the site. Those interested in attending the pre-bid conference should contact the Procurement Officer. Offerors are advised that anything discussed at the pre-bid conference does not change any part of this solicitation. All changes and/or clarifications to this solicitation shall be done in the form of written addenda.

**NOTICE OF INTENTION TO BID**: Prospective bidders shall file with the Manager and Chief Engineer, a written notice of intention to bid at least ten (10) calendar days prior to the day designated for the opening of bids, as required by HRS 103D-310.

MANAGER AND CHIEF ENGINEER  
DEPARTMENT OF WATER  
COUNTY OF KAUA‘I

POSTED: September 23, 2019

**INVITATION FOR BIDS  
AND  
CONSTRUCTION DOCUMENTS  
FOR**

**JOB NO. 17-10, WP2020 Project No. KW-07  
Rehabilitate Paua Valley Tank No. 1, 0.5 MG Concrete  
Kekaha Water System  
KAUA'I, HAWAI'I**

**September 2019**

**DEPARTMENT OF WATER  
COUNTY OF KAUA'I  
LĪHU'E, KAUA'I, HAWAI'I**

APPROVED:

  
\_\_\_\_\_  
Manager and Chief Engineer

9/18/19  
\_\_\_\_\_  
Date

# 1 ADMINISTRATION

## 1.1 Invitation For Bids.

DEPARTMENT OF WATER, COUNTY OF KAUA'I  
**17-10, WP2020 Project No. KW-07 Rehabilitate Paua Valley Tank No. 1, 0.5 MG Concrete  
Kekaha Water System  
KAUA'I, HAWAI'I**

Pursuant to Chapter 103D, HRS, SEALED TENDERS will be received up to and opened at 2:00 p.m., Hawaiian Standard Time (HST) on **Thursday, October 31, 2019**, in the Administration Office of the Department of Water at 4398 Pua Loke Street, Lihu'e, Kaua'i, Hawai'i ("DOW Admin. Office"). Bids received after the date and time specified above shall be rejected. Facsimile offers will not be accepted or considered.

The schedule set out below represents the Department's best estimate of the schedule that will be followed for this competitive sealed bidding procurement process. If an activity in the schedule is delayed, the dates following the delayed activity may be adjusted by the same number of days. All prospective Offerors will be advised by addendum of any changes to the Procurement Schedule.

Activity	Scheduled Date
Invitation For Bids Issued	September 23, 2019
Pre-Bid Conference	October 1, 2019 @ 8:30 AM HST
Deadline: Receipt of Questions / Comments / Material Substitutions	October 11, 2019
Deadline: Notice of Intent	October 21, 2019
Department's Responses to Questions / Comments / Material Substitutions	October 21, 2019
Bid Opening	October 31, 2019
Selection / Award Notification	November 2019
Contract Execution Period	November 2019-December 2019
Contract Tentative Notice to Proceed Date	January 2020

The Manager and Chief Engineer also reserves the right to reject any or all bids, in whole or in part, if deemed to be in the best interest of the Department of Water.

Bids must be signed in ink by the person or persons duly authorized to sign bids in the space provided for signature on the Offer form.

**BIDDERS ARE HEREBY NOTIFIED THAT EVIDENCE OF THE AUTHORITY OF THE PERSON(S) SIGNING THE BID DOCUMENT IS REQUIRED TO BE INCLUDED WITH THE BID DOCUMENTS. FAILURE TO COMPLY WITH THIS REQUIREMENT WILL BE CAUSE FOR REJECTION OF THE BID AS BEING NON-RESPONSIVE.**

**SCOPE OF WORK:** The 0.5 MG PAUA VALLEY TANK #1 is a 0.5 million gallon (MG) reinforced concrete reservoir, with an inside diameter of 69 feet and a maximum water height of 18 feet to the overflow pipe opening. The flat concrete roof is supported on the interior by four square  
Job No. 17-10, WP2020 Project No. KW-07 Rehabilitate Paua Valley Tank No. 1, 0.5 MG Concrete Kekaha Water System

concrete columns. Work includes installation of a level indicator system with gauge board, remove and replace the interior ladder, remove and replace the asphalt concrete pavement surrounding the reservoir, repair the leak at the base of the reservoir, spall repairs, install interior coating of the reservoir, repaint the entire reservoir including appurtenances, remove and replace the reservoir roofing system, mitigate hazardous materials associated with the repair work. The Project is located in the Kekaha, Kaua‘i, Hawai‘i area accessed by a gated unpaved access road from Kokee Road., as indicated in the contract drawings and specifications. |

**PLANS AND SPECIFICATIONS:** | The contract documents are to be downloaded electronically. Please email the Department of Water Departmental Contracts Officer, Christine Erorita at cerorita@kauaiwater.org for instructions. | May be examined and obtained at the DOW Admin. Office. Those who download documents electronically shall be responsible for any and all costs related to printing or reproducing the items as required for offer submission. For inquires on obtaining plans and specifications and all other inquires call the project engineer at (808) 245-5459. |

The contract documents may be examined at the following locations:

| DOW Admin. Office, Līhu‘e, Kaua‘i, Hawai‘i  
| Building Industry Digest Plan Room, Honolulu, Hawai‘i  
| General Contractors’ Association Plan Room, Honolulu, Hawai‘i |

Published in:  Garden Island Newspaper  
 Bid Service Weekly  
 General Contractors’ Association  
 State Procurement Internet website at: <https://hands.ehawaii.gov/hands/welcome>  
 PublicPurchase website at: [www.publicpurchase.com](http://www.publicpurchase.com)  
 DOW website at: [www.kauaiwater.org](http://www.kauaiwater.org)

**CONTRACTORS LICENSE:** All prospective Bidders must be currently licensed by the State of Hawai‘i, Department of Commerce and Consumer Affairs, Division of Professional and Vocational Licensing.

“A” general engineering contractors and “B” general building contractors are reminded that due to the Hawai‘i Supreme Court’s January 28, 2002 decision in Okada Trucking Co., Ltd. v. Board of Water Supply, et al, 97 Haw. 450 (2002), they are prohibited from undertaking any work, solely or as part of a larger project, which would require the general contractor to act as a specialty contractor in any area where the general contractor has no license. Although the “A” and “B” contractor may still bid on and act as the “prime” contractor on an “A” or “B” project (See, HRS § 444-7 for the definitions of an “A” or “B” project), respectively, the “A” and “B” contractor may only perform work in the areas in which they have the appropriate contractor’s license (An “A” or “B” contractor obtains “C” specialty contractor’s licenses either on its own or automatically under HAR § 16-77-32.). The remaining work must be performed by appropriately licensed entities. It is the sole responsibility of the contractor to review the requirements of this Project and determine the appropriate licenses that are required to complete the Project.

**PRE-BID CONFERENCE:** The estimated contract value is more than \$500,000 and, thus, a Pre-Bid Conference shall be held. If a Pre-Bid Conference is held, all potential interested offerors, subcontractors, and union representatives are invited to attend on the date specified in the Procurement Schedule in Section 1.1 at the DOW Admin. Office. A visit to the site will be conducted following the meeting. The site inspection is not mandatory; however, submission of an offer shall be evidence that the Offeror understands the scope of the project and shall comply with the specifications herein, if awarded the contract and has thoroughly familiarize itself with the existing conditions, rules and regulations, and the extent and nature of work to be performed. No additional compensation, subsequent to bid opening, shall be allowed by reason of any misunderstanding or error regarding site conditions or work to be performed. All prospective Bidders must make their own transportation arrangements to and from the site. Those interested in attending the pre-bid conference should contact the Procurement Officer. Offerors are advised that anything discussed at the pre-bid conference does not change any part of this solicitation. All changes and/or clarifications to this solicitation shall be done in the form of written addenda.

**NOTICE OF INTENTION TO BID:** Prospective bidders shall file with the Manager and Chief Engineer, a written notice of intention to bid at least ten (10) calendar days prior to the day designated for the opening of bids, as required by HRS 103D-310.

MANAGER AND CHIEF ENGINEER  
DEPARTMENT OF WATER  
COUNTY OF KAUA'I

## TABLE OF CONTENTS

<b>1</b>	<b>ADMINISTRATION.....</b>	<b>2</b>
1.1	INVITATION FOR BIDS. ....	2
1.2	DEFINITIONS. ....	7
1.3	INSTRUCTIONS TO BIDDERS. ....	9
1.4	GENERAL PROVISIONS, SPECIFICATIONS, AND STANDARD DETAILS. ....	16
1.5	PROCUREMENT OFFICER AND CONTRACT ADMINISTRATOR. ....	17
<b>2</b>	<b>SCOPE OF WORK.....</b>	<b>18</b>
2.1	SCOPE OF WORK. ....	18
2.2	TIME OF COMPLETION. ....	18
2.3	PERMITS. ....	19
2.4	CONTRACTOR’S RESPONSIBILITY FOR EXISTING UTILITIES AND STRUCTURES. ....	19
2.5	POWER AND WATER SUPPLIES. ....	19
2.6	CONTRACTOR’S LICENSE REQUIRED. ....	19
2.7	HOURS. ....	20
2.8	QUANTITIES.....	20
2.9	MATERIALS FURNISHED FOR THE PROJECT. ....	20
2.10	WORK TO BE DONE WITHOUT DIRECT PAYMENT.....	20
2.11	INTENT OF THE SPECIFICATIONS. ....	20
2.12	IMPLEMENTATION.....	20
2.13	GOVERNING LAW; APPLICATION OF LAW.....	21
<b>3</b>	<b>METHOD OF AWARD.....</b>	<b>22</b>
3.1	METHOD OF AWARD.....	22
3.2	HAWAI’I REVISED STATUTES. ....	22
3.3	RESPONSIBILITY OF SUCCESSFUL BIDDER.....	22
3.4	REQUIREMENT FOR AWARD. ....	23
3.5	TIMELY SUBMISSION OF ALL CERTIFICATES. ....	24
3.6	FINAL PAYMENT REQUIREMENTS. ....	24
<b>4</b>	<b>AWARD OF CONTRACT AND NOTICE TO PROCEED .....</b>	<b>25</b>
4.1	AWARD. ....	25
4.2	NOTICE OF AWARD. ....	25
4.3	NOTICE TO PROCEED. ....	25
	<b>APPENDIX A: SAMPLE CONTRACT (BOUND SEPARATELY).....</b>	<b>26</b>
	<b>APPENDIX B: GENERAL PROVISIONS FOR CONSTRUCTION CONTRACTS FOR THE DEPARTMENT OF WATER, DATED APRIL 25, 2016 (BOUND SEPARATELY).....</b>	<b>27</b>
	<b>APPENDIX C: OFFER.....</b>	<b>28</b>
	<b>APPENDIX D: INSURANCE (BOUND SEPARATELY).....</b>	<b>44</b>
	<b>APPENDIX E: WAGE CERTIFICATE FOR SERVICE CONTRACTS.....</b>	<b>45</b>

**APPENDIX F: CERTIFICATION OF COMPLIANCE FOR FINAL PAYMENT..... 46**

**APPENDIX G: APPRENTICESHIP PROGRAM..... 47**

**APPENDIX H: NOTICE OF INTENT TO PROPOSE..... 50**

**APPENDIX I: NPDES DOCUMENTS (BOUND SEPARATELY)..... 52**

**APPENDIX J: HAZARDOUS MATERIALS SURVEY REPORT (BOUND SEPARATELY).  
..... 53**

**APPENDIX K: EMPLOYMENT OF STATE RESIDENTS ON CONSTRUCTION  
PROCUREMENT CONTRACTS..... 54**

**APPENDIX L: CERTIFICATION OF COMPLIANCE WITH HRS 396-18, SAFETY AND  
HEALTH PROGRAMS FOR CONTRACTOR BIDDING ON BOARD  
JOBS..... 57**

**APPENDIX M: SPECIAL PROVISIONS..... 58**

**APPENDIX N: ENVIRONMENTAL PROTECTION AGENCY DOCUMENTS (BOUND  
SEPARATELY)..... 207**



## 1.2 Definitions.

This section shall incorporate the definitions not listed below and contained in Hawai‘i Revised Statutes (HRS) 103D; the Hawai‘i Administrative Rules (HAR), Title 3, Department of Accounting & General Services, Subtitle 11, Procurement Policy Board, Chapters 120 through 131; and the General Provisions for Construction Contracts of the Department of Water, dated April 25, 2016. Terms as used in this solicitation, unless the context requires otherwise, shall have the following meaning:

“Award” means the notification of the Department’s acceptance of a bid or the presentation of a contract to the selected offeror.

“Bid sample” means a sample to be furnished by a bidder to show the characteristics of the item offered in the bid.

“Board” or “Board of Water Supply” shall mean the “Department of Water, County of Kaua‘i”, as provided for in the County Charter which became effective January 2, 1969.

“Contract Administrator” means the person designated to manage the various facets of the Contract to ensure the Contractor’s total performance is in accordance with the contractual commitments and obligations to the Department are fulfilled.

“Department” or “DOW” means the Department of Water, County of Kaua‘i, contracting on behalf of the Board of Water Supply. Wherever the terms “Engineer” or “Owner” are used in any document which forms a part of the Contract, the terms shall mean the Department of Water, County of Kaua‘i and its authorized agents.

“Offer” means the bid, proposal, or quotation.

“Offeror” means any individual, partnership, firm, corporation, joint venture, or other legal entity submitting, directly or through a duly authorized representative or agent, an offer for the good, service, or construction contemplated.

“Opening” means the date set for opening of bids, receipt of unpriced technical offers in multistep sealed bidding, or receipt of proposals in competitive sealed proposals.

“Procurement officer” means any person with delegated authority to enter into and administer contracts and make written determination with respect thereto. The term includes an authorized representative acting within the limits of authority. The delegated authority is received from the chief procurement officer directly or through the head of a purchasing agency or designee to the procurement officer.

“Project” means work to be performed as set forth in the Contract, including furnishing all services, labor, goods, materials, supplies, equipment and other incidentals reasonably necessary for the successful completion of work contemplated under the Contract.

“Quotation” means a statement of price, terms of sale, and description of goods, services, or construction offered by a prospective seller to a prospective purchaser, usually for purchases pursuant to section 103D-305, HRS.

“Special Provisions” means the terms and conditions pertaining to the specific solicitation in which they are incorporated; including but not limited to terms and conditions describing the preparation of solicitations, evaluation of offers, determination of award, plus those applicable to performance by the Contractor.

Additions or revisions to the General Provisions, which shall be considered a part of the General Provisions, setting forth conditions or requirements applicable to the particular project or contract under consideration shall be included in the Special Provisions. Should any Special Provisions conflict with these General Provisions, said Special Provisions shall govern.

“Specifications” mean any description of the physical or functional characteristics, or of the nature of a good, service, or construction item. The term includes descriptions or any requirement for inspecting, testing, or preparing a good, service, or construction item for delivery.

“Standard commercial product” means a product or material, in the normal course of business, is customarily maintained in stock or readily available by a manufacturer, distributor, or dealer for the marketing of the product.

“Successful bidder” means the individual, partnership, firm, corporation, joint venture, or other legal entity that submitted a bid for the Project and was determined to be a responsible, responsive bidder and selected for award of the contract.

### 1.3 Instructions to Bidders.

THESE INSTRUCTIONS TO BIDDERS SHALL BE CONSIDERED TO BE INCORPORATED IN THE SPECIAL PROVISIONS.

- 1.3.1 SUBMISSION OF BIDS: Bidders shall read and examine the Special Provisions, Specifications, General Provisions and all other bid documents attached hereto and by reference made a part hereof. Submission of bids shall be deemed a verification of such reading and examination and shall be deemed acknowledgement and agreement to be bound by the terms and conditions, and specifications of such documents. All Bidders shall complete and submit with its bid, the Offer form found in Appendix C via [www.publicpurchase.com](http://www.publicpurchase.com) .

All bids for the construction of this project shall be submitted via [www.publicpurchase.com](http://www.publicpurchase.com) and marked “**17-10, WP2020 Project No. KW-07 Rehabilitate Paua Valley Tank No. 1, 0.5 MG Concrete Kekaha Water System.**”

- 1.3.2 BIDDING INSTRUCTIONS: In addition to these Instructions to Bidders, Bidders are directed to SECTION 2 - BIDDING / PROPOSAL INSTRUCTIONS of the “GENERAL PROVISIONS FOR CONSTRUCTION CONTRACTS OF THE DEPARTMENT OF WATER”, dated April 25, 2016 (hereafter “GENERAL PROVISIONS”), and the General Provisions in its entirety.
- 1.3.3 OFFER FORM: The attached form of the OFFER is furnished only for the guidance of bidders and is not to be used for actual bidding. An official copy of the Offer on which the bid shall be made will be furnished to the prospective bidder when plans and specifications are obtained.
- 1.3.4 OMISSION OR ERASURES; CONDITIONED OFFERS: Any Offer which contains any omission or erasure or alteration not properly initialed or any attempt by a bidder to condition the bid or other irregularity, and bid samples or descriptive literature, unless expressly requested, will not be examined or tested, and will not be deemed to vary any of the provisions of this Invitation for Bids and are submitted at the Bidder’s risk and may be rejected. Offerors shall not submit their organization’s terms and conditions, standard contracts, or other similar agreements or forms. General reference to such items or attempts to substitute such items for the Department’s **shall** result in the disqualification of the Offeror’s bid as conditioned.
- 1.3.5 SOLICITATION REVIEW; SUBMISSION OF QUESTIONS AND REQUESTS FOR CLARIFICATION:
- 1.3.5.1 Submission of Questions and Requests for Clarification: Offerors are encouraged to submit written questions pertaining to this Invitation for Bids. Questions and requests for clarification must be submitted in writing via e-mail or received by post mail to the Procurement Officer not later than the date specified in the Procurement Schedule in

Section 1.1 in order to generate an official answer. All written questions will receive an official written response from the Department and become an addenda to this Invitation for Bids. The only official position of the Department is that which is stated in writing and issued in this Invitation for Bids as an addenda thereto. All other means of communication, whether oral or written, shall not be formal or official responses/statements and may not be relied upon.

1.3.5.2 Solicitation Review: Offerors should carefully review this Invitation for Bids for defects and/or ambiguities. Comments concerning defects and questionable or objectionable matter must be made in writing either via e-mail or post mailed and should be received by the Procurement Officer not later than the date specified in the Procurement Schedule in Section 1.1. This will allow issuance of any necessary amendments to this Invitation for Bids. It will also assist in preventing the opening of offers upon which award may not be made due to a defective solicitation package.

1.3.6 STANDARD QUESTIONNAIRE AND FINANCIAL STATEMENT: When the Manager and Chief Engineer requires a prospective bidder to file a “Standard Qualification Questionnaire for Prospective Offerors on Department of Water Contracts,” the prospective bidder shall return a completed Standard Questionnaire, on the form provided by the Department, at least 48 hours prior to opening of bids. If this proves satisfactory, the bidder’s Offer will be received.

1.3.7 BID BOND: A bid bond for the value of at least 5% of the bid value shall accompany the bid.

1.3.8 RESPONSIBILITY OF BIDDERS TO STUDY SITE:

At the time of opening of bids, the Department shall presume that each Bidder has inspected the project site(s) and has read the Plans, Specifications, and other Contract Documents, including all Addenda and has become thoroughly familiar with them. The failure or omission of any Bidder to receive or examine any form, instrument, or document shall in no way relieve that Bidder from any obligation under the Bid or the Contract.

Each bidder must form an opinion of the character of the work and of the materials to be excavated, from an examination of the project site(s), from studies and inspection of available samples, records and reports and from any other investigations the Bidder may wish to make. Each Bidder must form an independent opinion of all the conditions affecting the work to be done and the labor and materials to be supplied, in order to make a Bid in sole reliance thereupon. Failure of a Bidder to become completely familiar with the labor and construction conditions under which the work is to be performed will not relieve that Bidder of any obligations to furnish all materials, equipment, and labor necessary to perform the work as set forth in this Invitation For Bids and to perform the Contract.

1.3.9 INSURANCE:

Contractor shall procure and maintain, on a primary basis and at its sole expense, at all times during the life of the contract insurance coverages, limits, including endorsements as described Appendix "D" - Insurance, against claims for injuries to persons or damages to property which may arise from or in connection with the performance of the work by the Contractor or the Contractor's agents, representatives, employees, or subcontractors. The requirements contained therein, as well as the Department's review or acceptance of insurance maintained by the Contractor is not intended to and shall not in any manner limit or qualify the liabilities or obligations assumed by the Contractor. Unless otherwise approved by the Manager and Chief Engineer, the policy or policies of insurance maintained by the Contractor shall provide the minimum limit(s) and coverage(s) as specified in the attached Appendix "D" - Insurance and be placed with an insurance carrier authorized to do business in this state and rated A-VII by A.M. Best.

1.3.10 TAX CLEARANCE: See: Subsection 3.5 - RESPONSIBILITY OF OFFERORS AND TAX CLEARANCE of the GENERAL PROVISIONS in its entirety. Further, the Bidder shall be required to submit a tax clearance with the bid Offer. Failure to comply with this provision will be grounds for disqualifying the Bidder. The successful bidder will also be required to submit a current valid tax clearance prior to final payment for this Project.

1.3.11 PREFERENCES: The following preferences are applicable when preceded by a checked box. Information and legal and procedural requirements pertaining to all preferences can be found within the General Provisions:

**Hawai'i Products Preference (See: Appendix C)**. Pursuant to HRS 103D-1002, Offers should complete the Certificate of Hawai'i Products Preference for application of this preference.

**Reciprocal Preferences**: Pursuant to the provisions of Section 103D-1004, HRS and Subchapter 3, Chapter 124, Subtitle 11, Title 3, HAR, the Manager may impose a reciprocal preference against Bidders from those states which apply preferences.

**Recycled Products Preference**. Pursuant to HRS 103D-1005, Offerors should contact the Procurement Officer for application of this preference.

**Tax Payer Preference (Hawai'i Excise and Use Tax Preference)**. Pursuant to HRS 103D-1008, any "taxpaying bidder" shall qualify for this preference.

**Qualified Community Rehabilitation Programs Preference**. Pursuant to HRS 103D-1009, a five per cent preference shall be given to services to be provided by nonprofit corporations or public agencies operating qualified community rehabilitation programs in conformance with criteria established by the DLIR for all competitive sealed bid and proposal procurements.

**Apprenticeship Program Preference (See: Appendix G).** Pursuant to HRS 103-55, applicable to public works projects with estimated values of \$250,000 or greater. Section 103-55.6, HRS, as enacted by S.B. 19, Act 17, SLH 2009, and the State of Hawai'i Comptroller's Memorandum 2011-06 as amended, provides for a Hawai'i Apprenticeship Preference for public works construction projects with estimated values of \$250,000 or greater. The preference shall be in the form of five percent (5%) bid adjustment applied to the Bidder's Offer amount.

**Safety and Health Program (See: Appendix N).** Pursuant to HRS 396-18, applicable to construction projects where the offer amount is in excess of \$100,000.

1.3.12 TAX ADJUSTMENT FOR OUT-OF-STATE VENDORS AND TAX EXEMPT BIDDERS: Pursuant to the provisions of Section 103-53.5, HRS, where the Bidder is an out-of-state vendor not doing business in the State of Hawaii, or is a person exempted from paying the applicable general excise tax, the package bid or purchase price, for the purpose of determining the lowest price bid, shall be increased by the applicable retail rate of general excise tax and the applicable use tax. The lowest responsible bidder who satisfies all of the requirements of these bid documents, taking into consideration the above increases, shall be awarded the contract, but the contract amount of any contract awarded shall be the amount of the bid offered and shall not include the amount of the increase.

1.3.13 WORKER'S COMPENSATION ACT: The Contractor will be required to comply with the provisions of Chapter 97, Revised Laws of Hawaii 1955, known as the "Worker's Compensation Laws," and all laws amendatory thereof, relating to the compensation of employees for personal injuries sustained in the course of their employment. The Contractor's surety or sureties shall be liable for any loss caused the Department by reason of the Contractor's failure to comply with the provisions of said laws.

The Contractor shall furnish to the Department one copy of certificate of said insurance prior to commencement of work. Refer to the "RESPONSIBILITY OF SUCCESSFUL BIDDER" for additional requirements.

1.3.14 SUBCONTRACTOR: Under the terms of this Contract, no subcontractor will be recognized. All subcontractors shall deal directly with the general Contractor; however, each and every subcontractor shall manage and take care of its own material and waste.

1.3.15 LISTING JOINT CONTRACTORS OR SUBCONTRACTORS:

Bidder shall complete the "[Joint Contractors or Subcontractors List](#)." It is the sole responsibility of the bidder to review the requirements of this Project and determine the appropriate specialty contractor licenses that are required to complete the Project. Failure of the bidder to provide the correct names and specialty contractor's nature of work to be performed may cause the bid to be rejected.

Bidder agrees the completed listing of joint contractors or subcontractors is required for the Project and that the bidder, together with the listed joint contractors and subcontractors, have all the specialty contractor licenses to complete the work.

Based on the Hawai‘i Supreme Court’s January 28, 2002 decision in Okada Trucking Co., Ltd. v. Board of Water Supply, et al., 97 Hawai‘i 450 (2002), the bidder as a general Contractor (‘A’ or ‘B’ license) is prohibited from undertaking any work solely or as part of a larger project, which would require the bidder (‘A’ or ‘B’ general Contractor) to act as a specialty (‘C’ license) Contractor in any area in which the bidder (‘A’ or ‘B’ general Contractor) has no specialty Contractor’s license. Although the ‘A’ and ‘B’ Contractor may still bid on and act as the “Prime Contractor” on an ‘A’ and ‘B’ project (See: HRS § 444-7 for the definitions of an ‘A’ and ‘B’ project.), respectively, the ‘A’ and ‘B’ Contractor may only perform work in the areas in which they have the appropriate Contractor’s license. The bidder (‘A’ or ‘B’ general Contractor) must have the appropriate ‘C’ specialty Contractor's licenses either obtained on its own, or obtained automatically under HAR §16-77-32.

General Engineering ‘A’ Contractors automatically have these ‘C’ specialty contractor licenses: C-3, C-9, C-10, C-17, C-24, C31a, C32, C-35, C-37a, C-37b, C-38, C43, C49, C-56, C-57a, C-57b, and C61.

General Building ‘B’ Contractors automatically have these ‘C’ specialty contractor licenses: C-5, C-6, C-10, C-12, C-24, C-25, C31a, C32a, C42a, and C-42b.

Instructions to complete the Joint Contractors or Subcontractors List:

Describe the nature of work to be performed by the specialty contractor for this Project and provide the complete firm name of the joint contractor or subcontractor in the respective columns. If the bidder is a general contractor and providing the work of the required specialty contractor, fill in the Bidder’s (general contractor’s) name and nature of work to be performed for this Project.

List only one joint contractor or subcontractor per required specialty contractor classification.

For projects with alternate(s), fill out the respective “Joint Contractors or Subcontractors List for the Alternate(s).” Bidder shall describe the nature of work to be performed by the specialty contractor on this Project for the respective alternate. Bidders shall fill in the complete firm name and nature of work to be performed by the respective joint contractor or subcontractor. If the joint contractor or subcontractor previously listed under base bid, listing under Alternate(s) is not required.

- 1.3.16 WAGES AND LABOR REQUIREMENTS: Pursuant to HRS Section 103-55, each bidder submitting an offer and list of subcontractors certifies that: **WAGES**: The service to be rendered shall be performed by employees paid not less than wages paid to public officers and employees for similar work; and **COMPLIANCE WITH LABOR LAWS**:

All applicable laws of the Federal and State governments relating to workmen's compensation, unemployment compensation, payment of wages, and safety will be fully complied with. The successful Bidder shall complete the Wage Certification in Appendix E.

- 1.3.16.1 In accordance with HRS Section 104-2 et seq., the Hawaii Director of Labor and Industrial Relations determines the prevailing wages applicable to the project. The wage rates are the minimum rates to be paid and may be revised. Contractors shall pay the applicable rates, as revised, at no cost to the Department. This is not a representation that labor can be obtained at these rates. It is the responsibility of bidders to inform themselves of local labor conditions and prospective changes or adjustments of wage rates. No increase in the contract price shall be allowed or authorized on account of the payment of wage rates in excess of those listed herein. Wage rate schedules are available at the office of the Department of Labor and Industrial Relations, State of Hawai'i.

Current Wage Rate Bulletin: 494 & 495

- 1.3.17 ASBESTOS CEMENT PIPE: All construction contract bids involving asbestos cement pipe, the Contractor shall remove, handle, and dispose of asbestos cement pipe in conformance with all applicable OSHA, State, and Federal regulations. The asbestos cement pipes shall be disposed of at an approved disposal site.
- 1.3.18 CHLORINATION SUBCONTRACTOR: All construction contract bids involving any chlorination work shall have a name listed for the C-37d Water Chlorination Subcontractor. Any bid not listing this subcontractor shall be rejected and disqualified. However, where the value of the work to be performed by the subcontractor is equal to or less than one percent of the total bid amount, the listing of the subcontractor may be waived if it is in the best interest of the Department.
- 1.3.19 SUBSTITUTE MATERIALS: Bidders contemplating submission of bids based on substitute materials must obtain prior written permission from the Department. Lists of substitute materials together with qualifying data shall be submitted on the Department's Request for Substitution form by the date set in the Procurement Schedule in Section 1.1, as evidenced by the time stamp of the Department, to the Procurement Officer for approval (the Request for Substitution form may be obtained from this individual). It is not the intent of the Department to exclude or limit the products. Any substitute material determined by the Department upon evaluation to be an acceptable equal, will be listed in an addendum to this solicitation, issued prior to the bid opening date. The Department is the sole judge as to the comparable quality and suitability of any substitute material and its decision shall be final. If a Bidder offers a product without the Department's pre-approval, the substitute material shall not be considered for award.
- 1.3.20 INDEPENDENT PRICE DETERMINATION: By submitting a bid, the bidder certifies that the price submitted was independently arrived at without collusion.



- 1.3.21 PROTESTS: Any protest shall be submitted in writing within five (5) working days after the posting of the notice of award; provided that a protest based upon the content of the solicitation shall be submitted in writing prior to the date set for receipt of offers. Any and all protests pursuant to Hawai'i Procurement Code, Chapter 103D-701 HRS and Section 3-126-3 HAR shall be submitted in writing to the Procurement Officer for this Invitation for Bids.
- 1.3.22 INCORPORATION BY REFERENCE: Bidders hereby agree that all documents referred to in the Table of Contents are hereby incorporated by reference into this Invitation for Bids.
- 1.3.23 SEVERABILITY: If any covenant, condition, or provision of this Invitation for Bids is held to be invalid by any court of competent jurisdiction, such holding shall not affect the validity of any other covenant, condition, or provision contained herein or incorporated by reference.
- 1.3.24 REMEDIES; ATTORNEYS FEES, AND COSTS: All remedies provided in this Invitation for Bids shall be deemed cumulative and additional, and not in lieu of or exclusive of each other or of any other remedy available at law or in equity arising hereunder. Should any legal proceedings at law or in equity arise under or in connection with this Invitation for Bids, the Contractor shall be responsible for all attorneys' fees and costs (including reasonable fees and charges for the services of paralegals or other personnel who operate for and under the supervision of such attorneys and whose time is usually charged to clients) and any other expenses incurred in connection with such proceedings.
- 1.3.25 DEPARTMENT'S RIGHT TO AUDIT: BOOKS AND RECORDS: The Contractor shall, at all times during the term hereof, maintain complete and accurate books and records of its operations, including employee time records, in a form consistent with good accounting practice, including such books and records as would normally be examined by an independent certified public accountant in performing an audit or examination of the Contractor's receipts and expenses in accordance with generally accepted auditing standards. The Department has the right to designate an independent auditor to review books and records that specifically relate to this project. Subcontractors shall be bound by the same requirements. See: SECTION 6.9 - CONTROL OF THE CONTRACT of the GENERAL PROVISIONS in its entirety.
- 1.3.26 CONFIDENTIAL MATERIAL: All bids are subject to public inspection as set forth in 3-122-30, HAR. Bidders shall request in writing nondisclosure of designated trade secrets or other proprietary data to be confidential. Such data shall accompany the bid and shall be readily separable from the bid in order to facilitate eventual public inspection of the non-confidential portion of the bid. To facilitate the release of the information requested, the Department is prepared to sign a Non-Disclosure Agreement if necessary, however, the Department cannot guarantee that designated data will be kept confidential. The offers are subject to disclosure rules set forth in Chapter 92F, HRS and Non-Disclosure Agreements are enforceable only to the extent that they do not conflict

with the provisions of Chapter 92F, HRS. The Bidder bears the burden of establishing that the designated data is exempted from the disclosure requirements set forth in Chapter 92F.

- 1.3.27 CANCELLATION OF THE SOLICITATION AND OFFER REJECTION: The Department reserves the right to cancel this solicitation and to reject any and all offers in whole or in part, and waive any defects, when it is determined to be in the best interest of the Department, pursuant to HAR 3-122-96 and 3-122-97.

The Department shall not be liable for any costs, expense, loss of profit, or damages whatsoever, incurred by the Offeror in the event this solicitation is cancelled or an offer is rejected.

#### 1.4 General Provisions, Specifications, and Standard Details.

The Special Provisions, plans, General Provisions, Water Standards, County of Kaua‘i Department of Public Works (“DPW”) Standard Specifications and Details, as amended, contract documents, and all supplemental documents are essential parts of the contract, and a requirement occurring in one is as binding as though occurring in all. They are intended to be complementary and to describe and provide for the complete work. In case of conflict or discrepancy within any part of the contract, the stricter requirements, including Hawai‘i State Statutory requirements, shall govern. Unless it is apparent that a different order of precedence is intended, the special provisions shall govern over plans, general provisions, and Water Standards; plans shall govern over general provisions; general provisions shall govern over Water Standards; Water Standards shall govern over DPW Standard Specifications; figured dimensions and drawings take precedence over measurements by scale, and detail drawings; instructions to proposers shall be incorporated and made a part of the special provisions.

It is the responsibility of the prospective offerors, offerors, and Contractors to review the General Provisions, Water Standards, Specifications, and Standard Details and a submission of an offer to this solicitation shall be deemed an acknowledgement of the incorporation of these into this solicitation and the resulting contract, if any.

##### 1.4.1 General Provisions for Construction Contracts.

The General Provisions for Construction Contracts of the Department of Water, dated April 25, 2016 (“General Provisions”) are included in this Invitation For Bids. A copy may be found in Appendix “B.”

- 1.4.2 Water System Standards. The “Water System Standards”, 2002, as amended, as adopted by the Department of Water, County of Kaua‘i; Board of Water Supply, City and County of Honolulu; Department of Water Supply, County of Maui; Department of Water Supply, County of Hawai‘i (“Water Standards”) is by reference incorporated herein and made a part of these specifications. The Water Standards specifications are not bound in these contract documents, but shall by reference be incorporated herein and made a part hereof.

- 1.4.3 Department of Public Works, County of Kaua‘i Standard Specifications: Whenever reference is made to the DPW Standard Specifications, the specifications referred to is the “HAWAI‘I STANDARD SPECIFICATIONS FOR ROAD, BRIDGE, AND PUBLIC WORKS CONSTRUCTION” of the State of Hawai‘i, 2005, as amended. These specifications are not bound in the Contract Documents, but shall by reference be incorporated herein and made a part hereof.
- 1.4.4 Department of Public Works, County of Kaua‘i, Standard Details: Whenever reference is made within these Special Provisions or the contract plans to the DPW Standard Details, the Details referred to is the “STANDARD DETAILS FOR PUBLIC WORKS CONSTRUCTION”, September 1984 and all subsequent amendments. These specifications are not bound in the Contract Documents, but shall by reference be incorporated herein and made a part hereof.

1.5 Procurement Officer and Contract Administrator.

The Procurement Officer is responsible for administrating/facilitating all requirements of the solicitation process and is the **sole point of contact for Offerors** from the date of release of the solicitation until the selection of the successful Bidder.

The Contract Administrator shall be responsible for the contract administration once the contract is awarded and shall be the point of contact throughout the term of the contract.

If checked, the Procurement Officer and the Contract Administrator shall be the same individual.

The Procurement Officer and Contract Administrator are:

**Procurement Officer:**

Dustin Moises  
 Chief of Construction Management  
 Department of Water, County of Kaua‘i  
 4398 Pua Loke Street  
 Lihu‘e, HI 96766  
 Phone Number: 808-245-5459  
 Email: dmoises@kauaiwater.org

**Contract Administrator:**

Claus Bollmann  
 Civil Engineer III  
 Department of Water, County of Kaua‘i  
 4398 Pua Loke Street  
 Lihu‘e, HI 96766  
 Phone Number: 808-245-5413  
 Email: cbollmann@kauaiwater.org |

## 2 SCOPE OF WORK

### 2.1 Scope of Work.

This Contract consists of the following Scope of Work and includes all other necessary work, all as indicated in the contract drawings and specifications. The general location of the work is as shown on the contract plans and as described herein.

[The 0.5 MG PAUA VALLEY TANK #1 is a 0.5 million gallon (MG) reinforced concrete reservoir, with an inside diameter of 69 feet and a maximum water height of 18 feet to the overflow pipe opening. The flat concrete roof is supported on the interior by four square concrete columns. Work includes installation of a level indicator system with gauge board, remove and replace the interior ladder, remove and replace the asphalt concrete pavement surrounding the reservoir, repair the leak at the base of the reservoir, spall repairs, install interior coating of the reservoir, repaint the entire reservoir including appurtenances, remove and replace the reservoir roofing system, mitigate hazardous materials associated with the repair work. The Project is located in the Kekaha, Kaua'i, Hawai'i. area accessed by a gated unpaved access road from Kokee Road. ]

### 2.2 Time of Completion.

2.2.1 It is understood and agreed that the work called for under this Project must and shall be completed within **455 CALENDAR DAYS** after written notice has been given to the Contractor to commence work. No extension of time will be granted for shipping and manufacturer's delays. The Contractor shall be subject to liquidated damages for delay or nonperformance as stated in this Invitation for Bids.

2.2.2 Work on the basic contract agreement is to be completed within the stipulated completion time from the date to the "Notice to Proceed." All work shall be done in cooperation with and coordinated with any other Contractors in a manner to allow completion of the entire construction within the scheduled time.

Per Approved Plans Water Construction Note all materials, shop drawings, chlorination plan, etc. shall be approved by the Department Construction Management Division before a preconstruction meeting can be scheduled. In order for the contractor to meet this requirement, as well as any other requirements related to permitting for the project including but not limited to building, grading, road, noise, demolition, NPDES for staging areas, NPDES duly authorized person designation, etc., the Department has included 90 calendar days for the contractor to complete the process within the total time of completion calendar day amount. Notice to proceed will be given before the contractor begins the project submittal approval process and it is expected that the contractor will complete the submittal and permit process within the 90 calendar day timeframe. No additional days will be granted if the contractor does not complete the process to attain a preconstruction meeting within 90 calendar days.

### 2.3 Permits.

A Hydrotesting Permit, File No. HI 18FF738, from the Department of Health, State of Hawai'i, has been obtained, and will expire at midnight, July 12, 2022, or when amendments to HAR, Chapter 11-55, Appendix F, are adopted, whichever occurs first. Should additional NPDES coverages be required, the Contractor shall prepare the required documents and obtain additional approvals, as necessary. The Contractor shall pay for all required charges and fees associated with these permits.

The Contractor shall obtain all necessary Environmental Protection Agency (EPA) permits relating to Polychlorinated Biphenyl (PCB) removal for the reservoir, including 1) a detailed work plan for PCB removal, transportation and disposal; 2) Contractor's closure report, including testing related to the PCB removal and clean-up; 3) Water quality testing results to verify PCB levels are acceptable. The Contractor shall pay for all required charges and fees associated with these permits.

The Contractor shall obtain all necessary clearances from the State Department of Health (DOH), Safe Drinking Water Branch and Hazard Evaluation and Emergency Response Office (HEER) prior to the reservoir being brought back on-line.

Notice to proceed will be given to the Contractor prior to attaining any additional permits. No time extension will be granted for the Contractor's inability to attain additional permits and the Contractor shall pay for all required charges and fees associated with these additional permits.

### 2.4 Contractor's Responsibility for Existing Utilities and Structures.

The existence and location of underground utilities and structures as shown on the plans are from the best information available but are not guaranteed and other obstacles may be encountered in the course of the work. Prior to the start of excavation, the Contractor shall contact all utility companies and have them locate their respective lines affected. The Contractor shall be held responsible for any damage to and for the maintenance and protection of existing utilities and structures. See: SECTION 6 - PERFORMANCE OF CONTRACT of the GENERAL PROVISIONS in its entirety.

### 2.5 Power and Water Supplies.

The Contractor shall make all the necessary arrangements and installation work that may be required for power and water supplies for the work under this Contract. Cost for said power and water supplies shall be included in appropriate unit prices bid and no direct payment will be made therefore.

### 2.6 Contractor's License Required.

The Department shall reject all bids received from contractors who are not licensed by the State Contractors License Board in accordance with Chapter 444, Hawai'i Revised Statutes.

It is the sole responsibility of the Bidder to review the requirements of this Project and determine the appropriate licenses that are required to complete the project.

2.7 Hours.

No work shall be done on Saturdays, Sundays, legal State Holidays and/or in excess of eight (8) hours each day without the written consent of the Contract Administrator. Should permission be granted to work at such times, the Contractor shall pay for all inspectional and administrative costs thereof. No work shall be done at night unless authorized by the Contract Administrator. No work shall be done at night during seabird fallout season (September 15 – December 15, annually). See: SECTION 6.9 and 6.12 of the GENERAL PROVISIONS.

2.8 Quantities.

All bids will be compared on the basis of quantities of work to be done, as shown in the bid; the quantities shown in the Unit Price items are estimated, being given as a basis for comparison of bids. The Department reserves the right to increase or decrease the quantities or delete items entirely as may be required during the progress of the work. See: SECTION 7.2 and 7.3 of the GENERAL PROVISIONS.

2.9 Materials Furnished for The Project.

All materials necessary for the completion of the project shall be furnished by the Contractor, unless specifically stated otherwise and full compensation thereof shall be included in the various items in the bid. All materials for this Project shall be ordered after the notice to proceed is issued and the shop drawings, if applicable, have been approved by the Department.

2.10 Work to Be Done Without Direct Payment.

Whenever it is specified in the contract that the Contractor is to do work or furnish materials of any kind for which no price is fixed in the contract, it shall be understood that such work or furnishing such materials was included in a unit price for the appropriate item, unless it is expressly specified that such work or material is to be paid for as extra work.

2.11 Intent of the Specifications.

It is not the intent of the DOW to limit Proposers to these specifications; however, the specifications designated as “requirements” contained herein are the minimum acceptable.

2.12 Implementation.

The Contractor will be required to:

2.12.1 Provide required permits for the construction of this Project, trained construction crew and project management necessary to ensure a complete constructed and fully functional water facilities as specified in this Invitation for Bids.

2.12.2 Provide all documentation, including all warranties and certification documents, on the construction materials being used.

2.13 Governing Law; Application of Law.

This Invitation for Bids and the Contract awarded based on such solicitation shall be governed by the laws of the State of Hawai‘i. The Contractor shall comply with all federal, State and local laws, regulations and ordinances, including occupational safety and health standards applicable to the performance of the services specified.

### **3 METHOD OF AWARD**

#### 3.1 Method of Award

3.1.1 Award, if made, shall be to the responsive, responsible Offeror submitting the lowest Total Sum Bid price.

3.1.2 Only those offers that meet all of the Invitation For Bids specifications, General Provisions, Special Provisions, and any other requirement contained herein will be considered for award. Any offer that proposes terms, conditions, or requirement that are contrary to those specified herein or does not meet the qualification requirements of this solicitation, as solely determined by the Department and as provided herein, may be considered nonresponsive and will be rejected as provided herein.

#### 3.2 Hawai'i Revised Statutes.

The Contractor's attention is called to the following chapters within the HRS which affect this Contract and the performance thereof:

Chapter 103, relating to expenditure of public money;

Chapter 104, relating to wages and hours of employees on public works;

Chapter 376, relating to industrial safety;

Chapter 386, relating to workmen's compensation;

Chapter 321, relating to the Health Department;

Section 507-17, relating to recovery on bond for material and labor used on public works; and

Chapter 378, relating to fair employment practices

#### 3.3 Responsibility of Successful Bidder.

3.3.1 The successful Bidder is advised that it shall, immediately prior to award of the contract, furnish proof of compliance with the requirements of HAR §3-122-112, to wit: Chapter 237, tax clearance; Chapter 383, unemployment insurance; Chapter 386, workers' compensation; Chapter 392, temporary disability insurance; Chapter 393, prepaid health care; and one of the following: a) Be registered and incorporated or organized under the laws of the State (hereinafter referred to as a "Hawai'i business"); or b) Be registered to do business in the State (hereinafter referred to as a "compliant non-Hawai'i business."

3.3.2 To comply with these requirements, the successful Bidder shall produce the following documents to the Department to demonstrate compliance with this section.

##### 3.3.2.1 HRS Chapter 237 Tax Clearance Requirement for Award and Final Payment.

Instructions are as follows:

Pursuant to HRS §103D-328, successful Bidder shall be required to submit a tax clearance certificate issued by the Hawai'i State Department of Taxation ("DOTAX") and the U.S. Internal Revenue Service ("IRS"). The certificate is valid



for six (6) months from the most recent approval stamp date on the certificate and must be valid on the date it is received by the Department of Water.

The tax clearance certificate shall be obtained on the State of Hawai‘i, DOT TAX CLEARANCE APPLICATION Form A-6 (Rev. 2003) which is available at the DOTAX and IRS offices in the State of Hawai‘i or the DOTAX website and by mail or fax:

DOTAX Website (forms & Information): <http://www.state.hi.us/tax/alphalist.html#a>  
DOTAX Forms by Fax/Mail: (808) 587-7572 / 1-800-222-7572

Completed tax clearance applications may be mailed, faxed or submitted in person to the Department of Taxation, Taxpayer Services Branch, to the address listed on the application.

DOTAX (fax): (808) 587-1488  
IRS (fax): (808) 539-1573

The application for the clearance is the responsibility of the Bidder and must be submitted directly to the DOTAX or IRS and not to the Department of Water.

3.3.3 HRS Chapters 383 (Unemployment Insurance), 386 (Workers’ Compensation), 392 (Temporary Disability Insurance), and 393 (Prepaid Health Care) Requirements for Award. Instructions are as follows:

Pursuant to HRS §103D-310, the successful Bidder shall be required to submit an approved certificate of compliance issued by the Hawai‘i State Department of Labor and Industrial Relations (“DLIR”). The certificate is valid for six (6) months from the date of issue and must be valid on the date it is received by the Department.

The certificate of compliance shall be obtained on the State of Hawai‘i, DLIR APPLICATION FOR CERTIFICATE OF COMPLIANCE WITH SECTION 3-122-112, HAR, Form LIR#27 which is available at [www.dlir.state.hi.us/LIR#27](http://www.dlir.state.hi.us/LIR#27), or at the neighbor island DLIR District Offices. The DLIR will return the form to the Bidder who in turn shall submit it to the Department.

The application for the certificate is the responsibility of the Bidder and must be submitted directly to the DLIR and not to the Department of Water.

3.4 Requirement for Award.

To be eligible for award, the Bidder must comply as follows:

3.4.1 Hawai‘i Business. A business entity referred to as a “Hawai‘i business” is registered and incorporated or organized under the laws of the State of Hawai‘i. As evidence of compliance, Bidder shall submit a CERTIFICATE OF GOOD STANDING issued by

the State of Hawai‘i Department of Commerce and Consumer Affairs Business Registration Division (“BREG”). A Hawai‘i business that is a sole proprietorship, however, is not required to register with the BREG and therefore not required to submit the certificate. A Bidder’s status as sole proprietor or other business entity and its business street address indicated on the OFFER form will be used to confirm that the Bidder is a Hawai‘i business.

- 3.4.2 Compliant Non-Hawai‘i Business. A business entity referred to as a “compliant non-Hawai‘i business” is not incorporated or organized under the laws of the State of Hawai‘i but is registered to do business in the State of Hawai‘i. As evidence of compliance, Bidder shall submit a CERTIFICATE OF GOOD STANDING.

To obtain a CERTIFICATE OF GOOD STANDING go online to [www.BusinessRegistrations.com](http://www.BusinessRegistrations.com) and follow the prompt instructions. To register or to obtain a “Certificate of Good Standing” by phone, call (808) 586-2727 (M-F 7:45 to 4:30 HST). The “Certificate of Good Standing” is valid for six months from date of issue and must be valid on the date it is received by the Department.

- 3.4.3 Bidders are advised that there are costs associated with registering and obtaining a “Certificate of Good Standing” from the DCCA.

### 3.5 Timely Submission of all Certificates.

- 3.5.1 The certificates described in this section should be applied for and submitted to the Department as soon as possible after the Department notifies the successful Bidder that the Department intends to issue an award to the successful Bidder. If valid certificates are not submitted within **ten (10) calendar days** after the Department so notifies the successful bidder, the successful Bidder’s offer may be disqualified and any prospective award (or actual award if mistakenly issued), even though the successful bidder’s bid is otherwise responsive and responsible, may be canceled without any liability whatsoever to the Department. The Department, and not the successful bidder, shall determine whether all necessary certificates have been timely submitted.

- 3.5.2 If the Department cancels any prospective or actual award for failure to submit all required certificates, the Department reserves the right to make an award to the next lowest responsive and responsible Bidder who is able to submit all the required certificates.

### 3.6 Final Payment Requirements.

Contractor is also required to submit a tax clearance certificate for final payment on the contract. A tax clearance certificate, not over two months old, with an original green certified copy stamp, must accompany the invoice for final payment on the contract. In addition to a tax clearance certificate, an original “Certification of Compliance for Final Payment” (SPO Form-22), will be required for final payment. This form is attached hereto as Appendix H.

#### **4 AWARD OF CONTRACT AND NOTICE TO PROCEED**

##### **4.1 Award.**

The successful Bidder shall comply with SECTION 3 - AWARD AND EXECUTION OF CONTRACT of the GENERAL PROVISIONS in its entirety.

##### **4.2 Notice of Award.**

The Procurement Officer will inform the successful Bidder of contract award selection within 48 hours of confirmation. Additionally, an official contract award notification letter will be executed by the Department and provided at the earliest date.

##### **4.3 Notice to Proceed.**

Upon contract execution, a “Notice to Proceed” letter will be provided to the Contractor specifying the “Commencement” (start work) date of the Contract. No work is to be undertaken by the Contractor prior to the commencement date specified in the Notice to Proceed letter. The Department is not liable for any work, contract, costs, expenses, loss of profits, or any damages whatsoever incurred by the Contractor prior to the official Notice to Proceed “Commencement” date.

**APPENDIX A:** Sample Contract (bound separately).

**APPENDIX B:** General Provisions for Construction Contracts for the Department of Water, dated April 25, 2016 (bound separately).

APPENDIX C: Offer.

Contractor \_\_\_\_\_

OFFER

For

DEPARTMENT OF WATER, COUNTY OF KAUA‘I,  
LĪHU‘E, KAUA‘I, HAWAI‘I

\_\_\_\_\_ 20 \_\_\_\_\_

Manager and Chief Engineer  
Department of Water  
County of Kaua‘i  
4398 Pua Loke Street  
Līhu‘e, Hawai‘i 96766

Dear Sir:

Pursuant to and in compliance with your Invitation For Bids and other Contract Documents relating thereto, the undersigned Offeror, having familiarized itself with the terms of the contract, the local conditions affecting the performance of the contract and the cost of the work at the place where the work is done, the plans and specifications, “General Provisions for Construction Contracts of the Department of Water”, “Water System Standards, 2002”, Invitation For Bids, and other Contract Documents, hereby proposes and agrees to perform, within the time stipulated in the said documents, including all its component parts and everything required to be performed, and to provide and furnish any and all of the labor, materials, tools, expendable equipment, and all utility and transportation services necessary to perform the contract, in a workmanlike manner, in place complete all of the work covered by the contract in connection with these specifications and accompanying construction plans titled:

**JOB NO. 17-10, WP2020 Project No. KW-07 Rehabilitate Paua Valley Tank No. 1, 0.5 MG  
Concrete Kekaha Water System, KAUA‘I, HAWAI‘I**

on file in the office of the Department of Water for,

TOTAL SUM OFFER \_\_\_\_\_ DOLLARS  
(words)

(\$ \_\_\_\_\_) said total sums being itemized on the following pages:

**Job No. 17-10, WP2020 Project No. KW-07 Rehabilitate Paua Valley Tank No. 1, 0.5 MG Concrete Kekaha  
Water System**

## OFFER SCHEDULE

JOB NO. 17-10, WP2020 Project No. KW-07, KAUA'I, HAWAI'I

ITEM NO.	ESTIMATED QUANTITY	DESCRIPTION	UNIT PRICE	TOTAL
1 (000931)	1	<b>Lump Sum.</b> Removal and disposal of lead-containing and lead-based paint (LCP/LBP), Polychlorinated Biphenyl (PCB) in accordance with the specifications, including air monitoring, TCLP testing, all incidentals, disposal as hazardous waste at an approved EPA disposal site, all in accordance with the plans and specifications.		\$
2 (000932)	1	<b>Lump Sum.</b> Install fluid-applied roofing system on reservoir roof, including surface preparation, membrane flashing and all appurtenant work, in place complete, including removing of the existing roofing system to the original concrete slab surface including loading, hauling and disposal and all incidentals, all in accordance with the plans and specifications.		\$
3 (000933)	100	<b>Lineal Feet.</b> Reservoir roof crack repair for concrete surfaces by routing and packing with crystalline mortar at exterior surface including surface preparation and curing of repairs and all incidentals, all in accordance with the plans and specifications, in place complete.	\$	\$
4 (000934)	30	<b>Square Feet.</b> Spall repairs at reservoir interior of underside of concrete roof slab, including surface preparation and curing of repairs and all incidentals, all in accordance with the plans and specifications, in place complete.	\$	\$
5 (000935)	1	<b>Lump Sum.</b> Install wall base joint sealant system, all appurtenances, in place complete, including removal of existing wall base joint sealant around entire perimeter of reservoir, and wall base joint leak test, all in		\$

ITEM NO.	ESTIMATED QUANTITY	DESCRIPTION	UNIT PRICE	TOTAL
		accordance with the plans and specifications, in place complete.		
6 (000936)	1	<b>Lump Sum.</b> Sampling, testing and report results of the existing wall base joint sealant for PCB, in accordance with the plans and specifications.		\$
7 (000937)	1	<b>Lump Sum.</b> Install interior coating of walls, pipe exteriors, floor and columns, all appurtenances, including surface preparation, all in accordance with the plans and specifications, in place complete.		\$
8 (000938)	150	<b>Lineal Feet.</b> Reservoir wall crack repair for concrete surfaces by routing and packing with crystalline mortar at exterior surface and interior repairs including surface preparation and curing of repairs and all incidentals, all in accordance with the plans and specifications, in place complete.	\$	\$
9 (000939)	1	<b>Lump Sum.</b> Paint reservoir exterior wall, bottom of roof overhang, and all accessories with paint finish, including reservoir hatch, ladder, and railing, inclusive of paint removal, surface preparation, caulking and sealants and all incidentals, all in accordance with the plans and specifications, in place complete.		\$
10 (000940)	1	<b>Lump Sum.</b> Install level indicator system, all appurtenances and incidentals, all in accordance with the plans and specifications, in place complete.		\$
11 (000941)	1	<b>Lump Sum.</b> Cleaning, leak testing, and disinfection of reservoir interior with EPA oversight, all in accordance with the plans and specifications.		\$
12 (000155)	275	<b>Square Yards.</b> Removal of existing AC pavement for 12 feet around reservoir, including loading, hauling and disposal and all incidentals, all in accordance with the plans and specifications.	\$	\$



ITEM NO.	ESTIMATED QUANTITY	DESCRIPTION	UNIT PRICE	TOTAL
13 (000354)	335	<b>Square Yards.</b> Install AC pavement and underlayment, including subgrade preparation and all incidentals, all in accordance with the plans and specifications, in place complete,	\$	\$
14 (000515)	1	<b>Lump Sum.</b> Install temporary erosion control measures, inclusive of silt fence, maintenance of erosion control BMP's, and other appurtenant work, all in accordance with the plans and specifications, in place complete.		\$
15 (000945)	1	<b>Lump Sum.</b> Install temporary PCB filtration system for discharging of reservoir water, inclusive of the installation of the Activated Carbon Filter Drums, piping, sump pump, excavation for containment pit and liner, and other appurtenant work and incidentals, including disassembling piping system, TCLP testing of (2) filter drums and drum disposal, backfill and compaction of pit, all in accordance with the plans and specifications, in place complete.		\$
16 (000946)	1	<b>Lump Sum.</b> Remove the existing interior ladder and install new stainless steel ladder and all incidental work, all in accordance with the plans and specifications, in place complete.		\$
		<b>TOTAL SUM OFFER (Items 1 to 16 inclusive)</b>		\$

**SCHEDULE B**  
**HAWAI'I PRODUCTS PREFERENCE**

In accordance with HRS §103D-1002, the Hawai'i products preference is applicable to this solicitation. Hawai'i Products ("HP") are available for those items noted on Schedule B, below. The Hawai'i products list is available on the SPO webpage at [www.spo.hawaii.gov/for-state-county-personnel/manual/procurement/solicitation/goods-services-construction/preferences/hawaii-product-preferences/](http://www.spo.hawaii.gov/for-state-county-personnel/manual/procurement/solicitation/goods-services-construction/preferences/hawaii-product-preferences/) or go to the SPO Home page, click on "For Vendors" tab; click on Preferences, Hawai'i Product Preferences to view. Offeror transmitting a Hawai'i Product (HP) shall identify the HP on Schedule B-1.

Any person desiring a Hawai'i product preference shall have the product(s) certified and qualified if not currently on the Hawai'i products list, prior to the deadline for receipt of offer(s) specified in the procurement notice and solicitation. The responsibility for certification and qualification shall rest upon the person requesting the preference. Persons desiring to qualify their product(s) not currently on the Hawai'i product list shall complete form SPO-038, Certification for Hawai'i Product Preference and submit, via email to the Procurement Officer issuing the solicitation, and provide the solicitation number and title in the subject line, and include all additional information required by the Procurement Officer. For each product, one form shall be completed and transmitted (i.e. 3 products should have 3 separate forms completed). Form SPO-038 is available on the SPO webpage at <http://hawaii.gov/spo> under the 'Quicklinks' menu; click on 'Forms for Vendors, Contractors, and Service Providers'.

When a solicitation contains both HP and non-HP, then for the purpose of selecting the lowest bid or purchase price only, the price offered for a HP item shall be decreased by subtracting 10% for the class I or 15% for the class II HP items offered, respectively. The lowest total offer, taking the preference into consideration, shall be awarded the contract unless the offer provides for additional award criteria. The contract amount of any contract awarded, however, shall be the amount of the price offered, exclusive of the preferences.

Change in Availability of Hawai'i product. In the event of any change that materially alters the Offeror's ability to supply Hawai'i products, the Offeror shall notify the Procurement Officer in writing no later than five (5) working days from when the Offeror knows of the change and the parties shall enter into discussions for the purposes of revising the contract or terminating the contract for convenience.

The following is a list of products that the Department anticipates will be used in this particular project; however the list is not all inclusive and additional products may be qualified.

**HAWAI'I PRODUCTS LIST**

HP Description	Manufacturer/Supplier	Class
----------------	-----------------------	-------

Bidders intending to use or supply a Hawai'i Product must list the price and total cost of each item f.o.b. jobsite, unloaded, including applicable general excise tax and use tax on this form. Failure to designate a Hawai'i product will mean that the Bidder is offering a non-Hawai'i product and award, if made to the bidder, will be on the basis that the bidder will deliver or use a non-Hawai'i product.

The Bidder shall list only the Manufacturers/Suppliers certified and qualified on Schedule B.

If the Department has awarded a contract under HRS, § 103D-1002, finds that in the performance of that contract there has been a failure to comply with HRS, § 103D-1002, the contract shall be voidable and the findings shall be referred for debarment or suspension proceedings under HRS 103D-702. Any purchase made or any contract awarded or executed in violation of this section shall be void and no payment shall be made by the Department on account of the purchase or contract.

SCHEDULE B-1  
SCHEDULE OF MATERIAL COST  
*(if Hawai'i preference requested)*

HAWAI'I PRODUCT	MANUFACTURER	CLASS	APPROX. QUANTITY	UNIT	TOTAL COST OF MATERIAL
Aggregates and Sand – Basalt, rock, cinder, limestone and coral					
Aggregates – Recycled asphalt and concrete					
Asphalt and paving materials					
Cement and concrete products					
Pre-cast concrete products					
Signs–traffic, regulatory and construction					
Soil amendments, mulch, compost					

SCHEDULE C  
MANDATORY LICENSING REQUIREMENT

“A” general engineering contractors and “B” general building contractors are reminded that due to the Hawai‘i Supreme Court’s January 28, 2002 decision in Okada Trucking Co., Ltd. V. Board of Water Supply, et al., 97 Haw. 450 (2002), they are prohibited from undertaking any work, solely or as part of a larger project, that would require the general contractor to act as a specialty contractor in any area in which the general contractor has no license. Although the “A” and “B” contractor may still submit an offer on and act as the “prime” contractor on an “A” and “B” project (*See, HRS § 444-7 for the definitions of an “A” and “B” project.*), respectively, the “A” and “B” contractor may only perform work in the areas in which they have the appropriate “C” specialty contractor’s license (*An “A” or “B” contractor obtains “C” specialty contractor’s licenses either on its own, or automatically under HAR § 16-77-32.*). The remaining work must be subcontracted out to appropriately licensed “C” specialty contractors. It is the sole responsibility of the contractor to review the requirements of this project and determine the appropriate licenses that are required to complete the project.

LISTING OF SUBCONTRACTORS

Sec. 103D-302, H.R.S., provides that each offer for Public Works Construction Contracts shall include the name of each person or firm to be engaged by the Offeror as a joint contractor or subcontractor in the performance of the Public Works Construction Contract. The Offer shall also indicate the nature and scope of the work to be performed by such joint contractors or subcontractors. All offers which do not comply with this requirement shall be rejected pursuant to Sec. 103D-302(b) H.R.S.

To comply with the above provisions, the offeror shall complete the schedule of the nature and scope of work by listing, where applicable, the names of the joint contractors and subcontractors to be used after the description of the nature and scope of the work.

ALL JOINT CONTRACTORS OR SUBCONTRACTORS TO BE ENGAGED ON THIS PROJECT

The Offeror certifies that the following is a complete listing of all joint contractors or subcontractors who will be engaged by the Offeror on this Project to perform the nature and scope of work indicated pursuant to Section 103D-302, Hawai‘i Revised Statutes, and understands that failure to comply with this requirement shall be just cause for rejection of the offer.

The Offeror further understands that only those joint contractors or subcontractors listed shall be allowed to perform work on this project, and that all other work necessary shall be performed by the Offeror with his or her own employees. If no joint contractor or subcontractor for any subdivision work is listed, it shall be construed that the work shall be performed by the Offeror with his or her own employees.

All Offerors must be sure that they possess and that the subcontractors listed in the Offer possess all the necessary specialty licenses needed to perform the work for this project. The Offeror shall be solely responsible for assuring that all specialty licenses required to perform the work is covered in his or her offer.

The Offeror shall include the license number of the joint contractors or subcontractors listed below. Failure to provide the correct names and license numbers as registered with the Contractor’s Licensing Board may cause rejection of the offer submitted.

**It is the sole responsibility of the contractor to review the requirements of this Project and determine the appropriate licenses that are required to complete the project.**

LISTING OF ALL JOINT CONTRACTORS OR SUBCONTRACTORS

	Contractor Classification	Name of Joint Contractor or Subcontractor	License Number
C-1	Acoustical and Insulation Contractor		
C-2	Mechanical Insulation Contractor		
C-3	Asphalt Paving and Surfacing Contractor		
C-3a	Asphalt Concrete Patching, Sealing, and Striping Contractor		
C-3b	Play Court Surfacing Contractor		
C-4	Boiler, Hot-Water Heating and Steam Fitting Contractor		
C-5	Cabinet, Millwork, and Carpentry Remodeling and Repairs Contractor		
C-5a	Garage Door and Window Shutters Contractor		
C-5b	Siding Application Contractor		
C-6	Carpentry Framing Contractor		
C-7	Carpet Laying Contractor		
C-9	Cesspool Contractor		
C-10	Scaffolding Contractor		
C-12	Drywall Contractor		
C-13	Electrical Contractor		
C-14	Sign Contractor		
C-15	Electronic Systems Contractor		
C-15a	Fire and Burglar Alarm Contractor		
C-15b	Telecommunications Contractor		
C-16	Elevator Contractor		
C-16a	Conveyor Systems Contractor		
C-17	Excavating, Grading, and Trenching Contractor		
C-19	Asbestos Contractor		
C-20	Fire Protection Contractor		
C-20a	Fire Repressant Systems Contractor		

	Contractor Classification	Name of Joint Contractor or Subcontractor	License Number
C-21	Flooring Contractor		
C-22	Glazing and Tinting Contractor		
C-22a	Glass Tinting Contractor		
C-23	Gunite Contractor		
C-24	Building Moving and Wrecking Contractor		
C-25	Institutional and Commercial Equipment Contractor		
C-27	Landscaping Contractor		
C-27a	Hydro Mulching Contractor		
C-27b	Tree Trimming and Removal Contractor		
C-31	Masonry Contractor		
C-31a	Cement Concrete Contractor		
C-31b	Stone Masonry Contractor		
C-31c	Refractory Contractor		
C-31d	Tuckpointing and Caulking Contractor		
C-31e	Concrete Cutting, Drilling, Sawing, Coring, and Pressure Grouting Contractor		
C-32	Ornamental, Guardrail, and Fencing Contractor		
C-32a	Wood and Vinyl Fencing Contractor		
C-33	Painting and Decorating Contractor		
C-33a	Wall Coverings Contractor		
C-33b	Taping Contractor		
C-33c	Surface Treatment Contractor		
C-34	Soil Stabilization Contractor		
C-35	Pile Driving, Pile and Caisson Drilling, and Foundation Contractor		
C-36	Plastering Contractor		
C-36a	Lathing Contractor		

	Contractor Classification	Name of Joint Contractor or Subcontractor	License Number
C-37	Plumbing Contractor		
C-37a	Sewer and Drain Line Contractor		
C-37b	Irrigation and Lawn Sprinkler Systems Contractor		
C-37c	Vacuum and Air Systems Contractor		
C-37d	Water Chlorination and Sanitation Contractor		
C-37e	Treatment and Pumping Facilities Contractor		
C-37f	Fuel Dispensing Contractor		
C-38	Post Tensioning Contractor		
C-40	Refrigeration Contractor		
C-40a	Prefabricated Refrigerator Panels Contractor		
C-41	Reinforcing Steel Contractor		
C-42	Roofing Contractor		
C-42a	Aluminum and Other Metal Shingles Contractor		
C-42b	Wood Shingles and Wood Shakes Contractor		
C-42c	Concrete and Clay Tile Contractor		
C-42e	Urethane Foam Contractor		
C-42g	Roof coatings Contractor		
C-43	Sewer, Sewage Disposal, Drain, and Pipe Laying Contractor		
C-43a	Reconditioning and Repairing Pipeline Contractor		
C-44	Sheet Metal Contractor		
C-44a	Gutters Contractor		
C-44b	Awnings and Patio Cover Contractor		
C-48	Structural Steel Contractor		
C-48a	Steel Door Contractor		
C-49b	Hot Tub and Pool Contractor		



	Contractor Classification	Name of Joint Contractor or Subcontractor	License Number
C-51	Tile Contractor		
C-51a	Cultured Marble Contractor		
C-51b	Terrazzo Contractor		
C-52	Ventilating and Air Conditioning Contractor		
C-55	Waterproofing Contractor		
C-56	Welding Contractor		
C-57	Well Contractor		
C-57a	Pumps Installation Contractor		
C-57b	Injection Well Contractor		
C-60	Solar Power Systems Contractor		
C-61	Solar Energy Systems Contractor		
C-61a	Solar Hot Water Systems Contractor		
C-61b	Solar Heating and Cooling Systems Contractor		
C-62	Pole and Line Contractor		
C-62a	Pole Contractor		
C-63	High Voltage Electrical Contractor		
C-68	Classified Specialist		
	Licensed Surveyor		
	Licensed Geotechnical Engineer		
	Licensed Structural Engineer		
	Archaeologist		
	Cultural Monitor		
	Licensed Civil Engineer		
	Supervising Control and Data Acquisition (SCADA) Contractor		
*			
*			
*			
*			

	Contractor Classification	Name of Joint Contractor or Subcontractor	License Number
*			
*			

\* Contractor to add licenses as required to complete the scope of work. Attach additional sheet as needed. It is understood and agreed that the Department reserves the right to reject any and/or all offers and waive any defects when, in the Department’s opinion, such rejection or waiver shall be for the best interest of the Department.

For purpose of evaluating the criterion described in this Invitation For Bids, it is understood and agreed that offers will be compared on the basis of the Total Sum Offer which shall be considered to be the total sum of actual or corrected amounts proposed on each item. The offerors signed Offer shall constitute the Offeror’s official offer. The Department reserves the right to designate the contract amount based on selected Offeror’s Total Sum Offer depending on the funds available for this Project.

It is also understood and agreed that the work called for under this Project must and shall be completed within **455** consecutive calendar days after written notice has been given to the successful Offeror to commence work. It is also understood and agreed that the quantities given herewith are approximate only and are subject to increase or decrease and that the undersigned will perform all quantities of work, as either increase or decrease, in accordance with the provisions of the specifications.

It is also understood and agreed that the estimated quantities shown for items for which a UNIT PRICE is listed in the Offer are only for the purpose of comparing on a uniform basis offers offered for the work under this contract, and the undersigned agrees that the undersigned is satisfied with and will not dispute said estimated quantities as a means of comparing the offers. It is understood and agreed that the Offeror will make no claims for anticipated profit or loss of profit because of a difference between quantities of the various classes of work done or the materials and equipment actually installed and the said estimated quantities. On UNIT PRICE offers, payment will be made only for the actual number of units incorporated into the finished project at the contract UNIT PRICE.

It is also understood and agreed that if the product of the UNIT PRICE offer and the number of units does not equal the total amount stated by the Offeror in the offer for any item, it will be assumed that the error was made in computing the total amount. For purpose of evaluating the criterion described in this Invitation for Bids, the stated UNIT PRICE alone will be considered as representing the Offeror’s intention and the total amount offered on such item shall be considered to be the amount arrived at by multiplying the UNIT PRICE by the number of units.

It is also understood and agreed that the liquidated damages in the amount of **\$One Thousand Dollars (\$1,000.00)** for each and every calendar day in excess thereof prior to completion of the contract beyond the specified and approved completion date, shall be withheld from payments due to the Contractor, pursuant to the Damages for Delay provision contained in this Invitation for Bids.

It is also understood and agreed that if this offer is accepted, the successful offeror will contract with the Board and said offeror shall furnish the required bonds to the Board within ten (10) days from the date of receiving from the Board the contract prepared and ready for execution.

It is further understood and agreed that the successful offeror will provide all necessary materials, labor, tools, equipment, and other incidental necessary to do all the work and furnish all the materials specified in the contract in the manner and time herein prescribed and according to the requirements of the Department as therein set forth.

The undersigned further understands and agrees that by submitting this Offer, 1) the Offeror is declaring that the Offer is not in violation of Chapter 84, Hawai'i Revised Statutes, and 2) Offeror is certifying that the price(s) submitted was (were) independently arrived at without collusion.

It is also understood and agreed that if this Offer is accepted and the undersigned shall fail to or neglect to contract as aforesaid, the Board may determine that the offeror has abandoned the contract and thereupon forfeiture of the security accompanying the Offer shall operate and the same shall become the property of the Board.

Enclosed herewith is a Bidder's Bond (Bid Security)	<input type="checkbox"/>	for the sum
Surety Bond	<input type="checkbox"/>	
Legal Tender	<input type="checkbox"/>	
Certificate of Deposit	<input type="checkbox"/>	
Share Certificate	<input type="checkbox"/>	
Cashier's Check	<input type="checkbox"/>	
Treasurer's Check	<input type="checkbox"/>	
Teller's Check	<input type="checkbox"/>	
Certified Check	<input type="checkbox"/>	

of \_\_\_\_\_ DOLLARS  
(\$ \_\_\_\_\_) payable to the Department of Water, being not less than the sum required under Sub-Section 2.9 "Bid Security" of the "General Provisions for Construction Contracts of the Department of Water", dated April 25, 2016.

Evidence of the undersigned Offeror having the authority to submit this Offer and to enter a contract is herewith furnished.

Respectfully submitted,

\_\_\_\_\_  
Name of Offeror

\_\_\_\_\_  
Authorized Signature

\_\_\_\_\_  
Print/Type Name & Title of above

\_\_\_\_\_  
Address, Zip Code

\_\_\_\_\_  
Telephone

\_\_\_\_\_  
Contractor's License No.

\_\_\_\_\_  
State of Hawai'i General Excise Tax License No.

\_\_\_\_\_  
Federal Employer Identification No.

Type of Organization: (Please designate)

- Sole Proprietorship     Partnership  
 Corporation             Joint Venture  
 Other (*please specify*) \_\_\_\_\_

State of Incorporation:         Hawai'i                     Other (*please specify*) \_\_\_\_\_

Name of Performance Bond Surety Co. \_\_\_\_\_

Address \_\_\_\_\_

Authorized to do Business in the State of Hawai'i?  Yes or  No

If corporation, state who will sign contract and signatory's title:

Name

Title

\_\_\_\_\_

\_\_\_\_\_  
Name

\_\_\_\_\_  
Title

\_\_\_\_\_  
\_\_\_\_\_  
**If Offeror is a CORPORATION**, the legal name of the corporation shall be set forth above, together with the signature(s) of the Officer(s) authorized to sign contracts on behalf of the corporation and the corporate seal affixed thereto. Please attach to this page evidence of the authority of the Officer (s) to sign on behalf of the Corporation.

**If Offeror is a PARTNERSHIP**, the true name of the firm shall be set forth above, together with the signature(s) of the Partner(s) authorized to sign on behalf of the partnership. Please attach to this page evidence of the authority of the Partner(s) to sign on behalf of the partnership.

**If Offeror is an INDIVIDUAL**, his or her signature shall be placed above.

If signature is by an agent, other than an Officer of a corporation or a member of a partnership, a POWER OF ATTORNEY must be filed with the Department prior to the Offer due date or submitted with the offer; otherwise, the offer may be rejected as irregular and unauthorized.

\_\_\_\_\_  
**NOTE:** PLEASE DO NOT DETACH THIS SAMPLE OFFER FROM THE SPECIFICATIONS. FILL IN ALL BLANK SPACES WITH INFORMATION REQUIRED OR OFFER MAY BE REJECTED.

**APPENDIX D: Insurance (Bound Separately)**

**APPENDIX E: Wage Certificate for Service Contracts**

**WAGE CERTIFICATE FOR CONSTRUCTION CONTRACTS**

Projects subject to HRS 104

TO: Manager and Chief Engineer

SUBJECT: Solicitation No.: \_\_\_\_\_

PROJECT: \_\_\_\_\_

Pursuant to **HRS 103-55.5 Wages and Hours of Employees on Public Works Construction Contracts**, I hereby certify that if awarded the contract in excess of \$2,000, the work to be performed will be performed under the following conditions:

1. Individuals engaged in the performance of the contract on the job site shall be paid:
  - a. Not less than the wages that the director of labor and industrial relations shall have determined to be prevailing for corresponding classes of laborers and mechanics employed on public works projects; and
  - b. Overtime compensation at one and one-half times the basic hourly rate plus fringe benefits for hours worked on Saturday, Sunday, or a legal holiday of the State or in excess of eight hours on any other day; and
2. All applicable laws of the federal and state governments relating to workers' compensation, unemployment compensation, payment of wages, and safety shall be fully complied with.

Offeror: \_\_\_\_\_

By: \_\_\_\_\_

Title: \_\_\_\_\_

Date: \_\_\_\_\_

**APPENDIX F: Certification of Compliance for Final Payment.**

**CERTIFICATION OF COMPLIANCE FOR FINAL PAYMENT**  
*(Reference §3-122-112, HAR)*

**Reference:** \_\_\_\_\_  
(Contract Number) (IFB/RFP Number)

\_\_\_\_\_ affirms it is in  
(Company Name)  
compliance with all laws, as applicable, governing doing business in the State of Hawai‘i to include the following:

1. Chapter 383, HRS, Hawai‘i Employment Security Law – Unemployment Insurance;
2. Chapter 386, HRS, Worker’s Compensation Law;
3. Chapter 392, HRS, Temporary Disability Insurance;
4. Chapter 393, HRS, Prepaid Health Care Act; and

maintains a “Certificate of Good Standing” from the Department of Commerce and Consumer Affairs, Business Registration Division.

Moreover, \_\_\_\_\_  
(Company Name)

acknowledges that making a false statement shall cause its suspension and may cause its debarment from future awards of contracts.

Signature: \_\_\_\_\_

Print Name: \_\_\_\_\_

Title: \_\_\_\_\_

Date: \_\_\_\_\_



## **APPENDIX G: Apprenticeship Program.**

Bidders seeking preference for this shall:

1. Be a party to an apprenticeship program registered with the State Department of Labor and Industrial Relations (DLIR) at the time of its Offer for each apprenticeable trade the Proposer will employ to construct the public works project for which the Offer is made; and
2. For each apprenticeable trade the proposer will employ for this project, submit with its Offer fully executed and authorized CERTIFICATION OF BIDDER'S PARTICIPATION IN APPROVED APPRENTICESHIP PROGRAM UNDER ACT 17. Schedule F attached to this solicitation verifying participation in apprenticeship program(s) registered with the DLIR.
3. The Contractor shall certify each month that work is being conducted on the project and that it continues to be a participant in the relevant apprenticeship program for each trade it employs. Monthly certification shall be made on MONTHLY REPORT OF CONTRACTOR'S PARTICIPATION IN APPROVED APPRENTICESHIP PROGRAM UNDER ACT 17 (Schedule F-I).

**SCHEDULE F - CERTIFICATION OF BIDDER'S PARTICIPATION IN APPROVED APPRENTICESHIP PROGRAM UNDER ACT 17**

<b>I. Bidder's Identifying Information</b>			
A. Legal Business Name: _____			
B. Project Bid Title & Reference No.: _____			
C. Contact Person's Name: _____			
1. Phone No.: _____		2. E-Mail: _____	
<b>II. Apprenticeable Trades To Be Employed*</b>	<b>B. Apprenticeship Sponsor*</b> (One Sponsor Per Form)	<b>C. No. Enrolled</b> (# of apprentices currently enrolled as of bidder's request date)	<b>D. No. Completed</b> (# of apprentices who completed the apprenticeship program in the 12 months prior to request date)
A. (List)			
1 .			
2 .			
3 .			
4 .			
5 .			
6 .			
<b>III. Bidder's Certification</b>			
I certify that the above information is accurate to the best of my knowledge, I understand that my willful misstatement of facts may cause forfeiture of the preference under Act 17 and may result in criminal action. I give permission for outside sources to be contacted and for them to disclose any information necessary to verify the bidder's preference.			
A. Name (Type) _____		B. Title _____	
C. Signature (original signature required) _____		D. Date _____	
<b>IV. Apprenticeship Sponsor's Contact Information</b>			
A. Training Coordinator's Name: _____			
B. Address: _____			
C. Phone No.: _____		D. E-Mail: _____	
E. Fax No: _____			
<b>V. Apprenticeship Program Sponsor's Certification</b>			
I certify that the above information is accurate to the best of my knowledge. I understand that my willful misstatement of facts may cause forfeiture of the bidder's preference and may result in criminal action. I give permission for outside sources to be contacted and for them to disclose any information necessary to verify the bidder's preference under Act 17.			
A. Name of Authorized Official _____		B. Title _____	
C. Signature (original signature required) _____		D. Date _____	

\* Name of Apprenticeable Trade and Apprenticeship Sponsor must be the same as recorded in the List of Construction Trades in Registered Apprenticeship Programs that is posted on the State Department of Labor and Industrial Relations website. (Rev. 08/25/2010)

**SCHEDULE F-1 - MONTHLY REPORT OF CONTRACTOR'S PARTICIPATION IN APPROVED APPRENTICESHIP PROGRAM UNDER ACT 17**

I. Contractor's Identifying Information		II. Reporting Period	
A. Legal Business Name:		A. Month: (choose)	B. Year: (choose)
B. Project Bid Title & Reference No.:			
C. Contact Person's Name:			
1. Phone No.:		2. E-Mail:	
III. Apprenticeship Program (Complete a separate form for <i>each</i> apprenticeship program in which workers are employed on the project)			
A. Contractor was a party to an apprenticeship program or programs with the following sponsor: (Give sponsor's name(s).*		B. Was the contractor a party to the program during the <i>entire</i> report month?	
		A. YES <input type="checkbox"/>	
		B. NO <input type="checkbox"/> If NO, state applicable period and why (may be subject to sanctions.)	
III. Contractor's Certification			
I certify that the above information is accurate to the best of my knowledge. I understand that my willful misstatement of facts may cause forfeiture of the preference under Act 17 and may result in criminal action. I give permission for outside sources to be contacted and for them to disclose any information necessary to verify the bidder's preference.			
_____		_____	
A. Name (Type)		B. Title	
_____		_____	
C. Signature (original signature required)		D. Date	
IV. Apprenticeship Sponsor's Contact Information			
A. Training Coordinator's Name: _____			
B. Address: _____			
C. Phone No.: _____		D. E-Mail: _____	
E. Fax No: _____			
V. Apprenticeship Program Sponsor's Certification			
I certify that the above information is accurate to the best of my knowledge. I understand that my willful misstatement of facts may cause forfeiture of the bidder's preference and may result in criminal action. I give permission for outside sources to be contacted and for them to disclose any information necessary to verify the bidder's preference under Act 17.			
_____		_____	
A. Name of Authorized Official		B. Title	
_____		_____	
C. Signature (original signature required)		D. Date	

\* Name of Name of Apprenticeship Sponsor must be the same as recorded in the list of Construction Trades in Registered Apprenticeship Programs that is posted on the State Department of Labor and Industrial Relations website. (Rev. 08/25/2010)

**APPENDIX H: Notice of Intent to Propose.**

**NOTICE OF INTENT**

\_\_\_\_\_  
DATE

Manager and Chief Engineer  
Department of Water  
County of Kaua'i  
4398 Pua Loke Street  
Lihu'e, HI 96766

Dear Sir:

In accordance with the Provisions of Section 103D-310, Hawai'i Revised Statutes, you are hereby notified that it is the intent of the undersigned to offer on **JOB NO. 17-10, WP2020 Project No. KW-07 Rehabilitate Paua Valley Tank No. 1, 0.5 MG Concrete Kekaha Water System, KAUA'I, HAWAI'I**, for which Offers will be due on **October 31, 2019** as required.

I am informed that this Notice of Intent must be received by the Manager no later than 4:30 p.m. Hawai'i Standard Time on **Monday, October 21, 2019**.

VERY TRULY YOURS,

\_\_\_\_\_  
SIGNATURE

\_\_\_\_\_  
PRINT OR TYPE NAME & TITLE OF SIGNER

Hawai'i State Specialty License  
Type and Classification:

\_\_\_\_\_  
NAME OF FIRM

\_\_\_\_\_  
CONTRACTORS LICENSE NO.

Hawai'i State Business  
License No.:

\_\_\_\_\_  
ADDRESS

\_\_\_\_\_  
CITY, STATE & ZIP CODE

\_\_\_\_\_  
TELEPHONE NO.

All prospective offerors must be currently licensed by the Hawai'i Department of Commerce and Consumer Affairs, Division of Professional and Vocational Licensing.

"A" general engineering contractors and "B" general building contractors are reminded that due to the Hawai'i Supreme Court's January 28, 2002 decision in Okada Trucking Co., Ltd. v. Board of Water Supply, et al., 97 Haw. 450(2002), they are prohibited from undertaking any work, solely or as part of a larger project, which would require the general contractor to act as a specialty contractor in any area where the general contractor has no license. Although the "A" and "B" contractor may still submit a Offer on and act as the "prime" contractor on an "A" or "B" project (See, HRS §444-7 for the definitions of an "A" or "B" project.), respectively, and the "A" and "B" contractor obtains "C" specialty contractor's licenses either on its own, or automatically under HAR §16-77-32.). The remaining work must be performed by appropriately licensed entities. It is the sole responsibility of the contractor to review the requirements of this project and determine the appropriate licenses that are required to complete the project.

**APPENDIX I: NPDES Documents (Bound Separately)**

**APPENDIX J: Hazardous Materials Survey Report (Bound Separately).**

“Targeted Hazardous Material Survey Report for County of Kauai Department of Water 0.5 MG Paua Valley Tank #1 Repair Project, Island of Kaua‘i.

## APPENDIX K: Employment of State Residents on Construction Procurement Contracts.

### a. Definitions

“Contract” means contracts for construction under Chapter 103D HRS.

“Contractor” has the same meaning as in section 103D-104, HRS; provided that contractor includes a subcontractor where applicable

“Construction” has the same meaning as in section 103D-104 HRS

“Procurement Officer” has the same meaning as in section 103D-104 HRS

“Resident” means a person who is physically present in the state at the time the person claims to have established the person’s domiciled in the state and shows the person’s intent is to make Hawai‘i the person’s primary residence.

“Shortage trade” means a construction trade in which there is a shortage of Hawai‘i residents qualified to work in the trade.

### b. Requirements of Contractor

The contractor awarded this contract shall ensure that Hawai‘i Residents compose not less than eighty percent (80%) of the workforce employed to perform this Contract, calculated as follows:

The eighty percent (80%) requirement shall be determined by dividing the total number of hours worked on a contract by Residents by the total number of hours worked by all employees of the Contractor in the performance of the Contract. Hours worked for any subcontractor of the contractor shall count towards the calculation for purposes of this subsection. The hours worked by employees within shortage trades, as determined by the Department of Labor and Industrial Relations, shall not be included in the calculations for purposes of this subsection.

This requirement shall be applicable during the entire duration of this Contract. A notarized Certification for Employment of State Residents on Construction Procurement Contracts (Schedule I) shall be submitted on a monthly basis with your request for progress payments. If no request for progress payments are made for any month, the Contractor is still responsible to submit the certification on a monthly basis.

### c. Penalties

Failure to comply with this requirement shall be subject to any of the following sanctions:

- A. Temporary suspension of work on the project until the Contractor or subcontractor complies with Act 68;
- B. Withholding of payment on the Contract or subcontract as applicable, until the Contractor or subcontractor complies with Act 68;
- C. Permanent disqualification of the Contractor or subcontractor from any further work on the project;



- D. Recovery by the Department of any moneys expended on the Contract or subcontract, as applicable; or
- E. Proceedings for debarment or suspension of the contractor or subcontractor under section 103D-702.

d. Conflict with Federal Law

Act 68 shall not apply if the application of the Act is in conflict with any federal law, or if application of Act 68 will disqualify the Department from receiving federal funds or aid.

CERTIFICATION OF COMPLIANCE  
FOR  
EMPLOYMENT OF STATE RESIDENTS  
ACT 68, SESSION LAWS OF HAWAI'I 2010

Project Title: \_\_\_\_\_

DOW Project No.: \_\_\_\_\_

Contract No.: \_\_\_\_\_

As required by Act 68, Session Laws of Hawai'i 2010 – Employment of State Residents on Construction Procurement Contracts, I hereby certify under oath, that I am an officer of \_\_\_\_\_ (*Name of Company*) and for the month of \_\_\_\_\_, 20\_\_\_\_, \_\_\_\_\_ (*Name of Company*) is in compliance with Act 68, SLH 2010, by employing a workforce of whom not less than eighty percent are Hawai'i residents, as calculated according to the formula in the solicitation, to perform this Contract.

- I am an officer of the Contractor for this contract.
- I am an officer of the Subcontractor for this contract.

*CORPORATE SEAL*

\_\_\_\_\_  
(Name of Company)

\_\_\_\_\_  
(Signature)

\_\_\_\_\_  
(Print Name)

\_\_\_\_\_  
(Print Title)

NOTARY CERTIFICATION

**APPENDIX L: Certification of Compliance with HRS 396-18, Safety and Health Programs for Contractor Bidding On Board Jobs**

PROJECT NAME: \_\_\_\_\_

SOLICITATION NO.: \_\_\_\_\_

This is to certify that the undersigned will comply with the requirements of HRS 396-18, as follows:

(A) Pursuant to HRS 396-18, all bids and proposals in excess of \$100,000 shall include a signed certification from the bidder that a written safety and health plan for the job will be available and implemented by the notice to proceed dates of the project. The written safety and health plan shall include:

- (1) A safety and health policy statement reflecting management commitment;
- (2) A description of the safety and health responsibilities of all levels of management and supervisors on the job, and a statement of accountability appropriate to each;
- (3) The details of:
  - (a) The mechanism for employee involvement in job hazard analysis;
  - (b) Hazard identification, including periodic inspections and hazard correction and control;
  - (c) Accident and “near-miss” investigations; and
  - (d) Evaluations of employee training programs.
- (4) A plan to encourage employees to report hazards to management as soon as possible and to require management to address these hazards promptly; and
- (5) A certification by a senior corporate or company manager that the plan is true and correct.

(B) Failure to submit the required certification may be grounds for disqualification of the bid.

(C) Failure to have available on site or failure to implement the written safety and health plan by the project’s Notice to Proceed Dates shall be considered willful noncompliance and be sufficient grounds to disqualify the award and terminate the contract.

Name of Contractor: \_\_\_\_\_

Signature and Title: \_\_\_\_\_

Date: \_\_\_\_\_

**APPENDIX M: Special Provisions.**

**TABLE OF CONTENTS FOR SPECIAL PROVISIONS**

**SECTION SP-1 – GENERAL REQUIREMENTS**

<u>SECTION</u>	<u>DESCRIPTION</u>
1.1	General Provisions, Specifications and Standard Details
1.2	Preconstruction Conference
1.3	Contractor’s Responses by Hardcopy or Facsimile
1.4	Failure To Complete On Time And Liquidated Damages
1.5	Measurements
1.6	Project Record Drawings
1.7	Substitutions
1.8	Storage, Work Zone, Construction Access
1.9	Preservation of Property
1.10	Extra Work
1.11	Building Laws
1.12	Delivery of Materials At Site
1.13	Defective Materials
1.14	Clean-Up
1.15	Environmental Protection
1.16	Project Sign
1.17	Submittals
1.18	Construction Coordination

**SECTION SP-2 – EXISTING CONDITIONS – ASBESTOS / LEAD / HAZARDOUS MATERIAL SURVEY**

**SECTION SP-3 – REMOVAL AND DISPOSAL OF MATERIAL CONTAINING ASBESTOS**

**SECTION SP-4 – LEAD HAZARD CONTROL**

**SECTION SP-5 – REMOVAL AND DISPOSAL OF BULK MATERIAL CONTAINING PCB**

**SECTION SP-6 – TESTING/AIR MONITORING**

SECTION SP-7 – CONCRETE REPAIR

SECTION SP-8 – RESERVOIR JOINT SEAL REPLACEMENT

SECTION SP-9 – PROTECTIVE COATINGS

SECTION SP-10 – LIQUID-APPLIED ROOFING SYSTEM

SECTION SP-11 – EXTERIOR COATINGS

SECTION SP-12 – NATIONAL POLLUTANT DISCHARGE ELIMINATION SYSTEM

SECTION SP-13 – DISCHARGING PCB-CONTAINING WATER

SECTION SP-14 – LEAK TESTING & DISINFECTION FOR RESERVOIR REPAIR

SECTION SP-15 – MISCELLANEOUS METAL FABRICATION

SECTION SP-16 – FIELD OFFICE

## SPECIAL PROVISIONS

### SECTION SP-1 – GENERAL REQUIREMENTS

1.1 GENERAL PROVISIONS, SPECIFICATIONS, AND STANDARD DETAILS: The special provisions, plans, general provisions, Water Standards, DPW Standard Specifications and Details, contract documents and all supplemental documents are essential parts of the contract, and a requirement occurring in one is as binding as though occurring in all. They are intended to be complementary and to describe and provide for the complete work. In case of conflict or discrepancy within any part of the contract, the stricter requirements, including Hawai'i State Statutory requirements, shall govern. Unless it is apparent that a different order of precedence is intended, the special provisions shall govern over plans, general provisions and Water Standards; plans shall govern over general provisions; general provisions shall govern over Water Standards; Water Standards shall govern over DPW Standard Specifications; figured dimensions and drawings take precedence over measurements by scale, and detail drawings; instructions to proposers shall be incorporated and made a part of the special provisions.

1.1.01 GENERAL PROVISIONS FOR CONSTRUCTION CONTRACTS OF THE DEPARTMENT OF WATER, COUNTY OF KAUA'I: The "GENERAL PROVISIONS FOR CONSTRUCTION CONTRACTS OF THE DEPARTMENT OF WATER, COUNTY OF KAUA'I", April 25, 2016 as amended, is by reference incorporated herein and made a part of these specifications.

1.1.02 WATER SYSTEM STANDARDS: The "WATER SYSTEM STANDARDS", 2002, as amended, as adopted by the Department of Water, County of Kaua'i; Board of Water Supply, City and County of Honolulu; Department of Water Supply, County of Maui; Department of Water Supply, County of Hawai'i is by reference incorporated herein and made a part of these specifications. These specifications are not bound in these contract documents, but shall by reference be incorporated herein and made a part of these specifications.

### SECTION 302 WATER MAINS AND APPURTENANCES

The following shall supplement the applicable subsections of Division 300 - Construction of the "Water System Standards", 2002.

Make the following amendments to said section:

#### SECTION 302.02 – TRENCH EXCAVATION.

Add the following paragraph to the "A. General" subsection:

Because construction will occur within residential neighborhoods, the Contractor shall secure all areas under construction with due regard for the safety of all persons and property at all times.

Amend the first paragraph of the "B. Payment" subsection to read:

Payment for trench excavation (without classification), backfill, select borrow, pipe cushion, and cost to safely secure all areas under construction will not be paid for

separately but shall be included in the Unit Price for the furnishing and installation of the various items in the Offer.

SECTION 302.03 – TRENCH BACKFILL.

Add the following paragraph to the “A. General” subsection:

If backfilling ground is continuously wet, pipe cushion and backfill material shall consist of coarse aggregate, ASTM C 33, Size Number 67, and shall be completely encapsulated with non-woven geotextile filter fabric unless approval for other material is granted.

Amend the first paragraph of the “G. Payment” subsection to read:

Payment for aggregate and sand pipe cushion surrounding the pipe, pipe bedding, non-woven geotextile filter fabric pipe cushion encasement, trench backfill, select borrow, warning tape, and backfill at valve boxes, meter boxes, manholes, and handholes will not be paid for separately but shall be included in the Unit Price for the furnishing and installation of the various items in the Proposal.

SECTION 302.04 – SHEATHING.

Add the following paragraph to the “A. General” subsection:

Contractor shall provide and maintain sheathing and bracing as necessary to support excavation and trenching and shall comply with Occupational Safety & Health Administration (OSHA) requirements. The contractor shall deem a competent person for trench excavation and that person shall be on-site during all trench excavation and backfill.

Amend the entire “B. Payment” subsection to read:

Payment for installation and removal of sheathing and bracing, and for additional excavation (without classification), additional aggregate and sand cushion to surround the pipe, additional non-woven geotextile filter fabric to surround the cushion, additional bedding, and additional backfill required because of sheathing or bracing work will not be paid for separately but shall be included in the Unit Price for the furnishing and installation of the various items in the Proposal.

SECTION 302.05 – DEWATERING.

Amend the first paragraph of the “A. General” subsection to read:

In locations where water is present in the trench, the Contractor must dewater by pumping or other means to keep the trench free of water during the installation of pipe cushion, the pipe itself, the testing, connection, relocation, lowering of the water mains, and until backfilling is completed to a point 12 inches above the top of the pipe. The Contractor shall provide proper facilities for delivering all pump water to its intended outfall location and attain all necessary permits required for discharge.

If the Contractor elects to discharge dewatering effluent into State Waters or existing drainage systems, the Contractor shall obtain NPDES General Permit Coverage authorizing discharges associated with construction activity dewatering from the Department of Health, Clean Water Branch (DOW-CWB). The Contractor shall prepare and submit permit application (CWB-NOI Form G) to DOH-CWB and shall not begin dewatering activities until DOH-CWB has issued Notice of General Permit Coverage (NGPC) and shall conduct dewatering operations in accordance with the conditions in NGPC. Contractor shall submit a copy of NPDES dewatering Application and Permit to the Manager.

Amend the entire “B. Payment” subsection to read:

Payment for dewatering activities, including but not limited to the preparation and implementation of NPDES General Permit Coverage authorizing discharges associated with construction activity dewatering, and the installation, maintenance, monitoring, and removal of Best Management Practices (BMPs), will not be paid for separately but shall be included in the Unit Price for the furnishing and installation of the various items in the Proposal.

For all fines received by the Department for non-compliance with the Notice of General Permit Coverage (NGPC), the Contractor shall reimburse the Department within 30 days for the full amount of the outstanding cost the Department has incurred, or the Department will deduct the cost from the Contractor’s progress payment.

SECTION 302.06 – “ADOBE” OR CLAY.

Amend the entire “B. Payment” subsection to read:

Exclusive of the payments due for work defined in Section 302.07 – MUD REMOVAL AND CRUSHED ROCK TRENCH STABILIZATION, no separate payment for excavation (without classification) and removal of adobe, clay or other unsuitable material from the pipe trench or for necessary backfill material approved by the Manager to replace those materials will be made; the compensation for such work shall be deemed to be included in the Unit Price for the furnishing and installation of the various items in the Proposal.

SECTION 302.07 – MUD REMOVAL AND CRUSHED ROCK TRENCH STABILIZATION.

Amend the first paragraph of the “B. Payment” subsection to read:

Payment for excavation (without classification) to remove and dispose of mud or undesirable materials from the pipe trench whether native or caused by contractor means and methods will not be paid for separately but shall be included in the Unit Price for the furnishing and installation of the various items in the Proposal.

SECTION 302.08 – BLASTING.

Amend the entire “A. General” and “B. Payment” subsections to read:



No blasting shall be allowed on this project.

SECTION 302.09 – EXCAVATION FOR MANHOLES.

Amend the second paragraph of the “B. Payment” subsection to read:

Payment for excavation (without classification) for manholes will not be paid for separately but shall be deemed to be included in the Unit Price for the furnishing and installation of Manholes.

SECTION 302.10 - EXCAVATION FOR THRUST BLOCKS, BEAMS, AND TEST BLOCKS.

Amend the entire “B. Payment” subsection to read:

Payment for excavation (without classification) and backfill of concrete thrust blocks, thrust beams, reaction blocks, and test blocks will not be paid for separately but shall be included in the Unit Price for installation of Concrete Thrust Blocks, Thrust Beams, Reaction Blocks, and Test Blocks or Waterline installation line items.

SECTION 302.11 – SURPLUS EXCAVATION.

Amend the entire “B. Payment” subsection to read:

Payment for the removal and disposal of surplus excavation material will not be paid for separately but shall be included in the Unit Price for the furnishing and installation of the various items in the Proposal.

SECTION 302.12 - DUCTILE IRON PIPE.

Add the following paragraph to the “A. General” subsection:

Transition couplings shall be Romac Style “501”, Style “RC501”, or approved equal. D.I. to A.C. transition couplings shall be 14" in length.

Add the following paragraphs to the “E. Payment” subsection:

The Unit Price for furnishing and installation of the various sizes of Ductile Iron Pipe shall be inclusive of trench excavation (without classification), trench backfill, pipe cushion, warning tape, sheathing and dewatering of trench, removal and disposal of adobe, clay, mud, and other unsuitable material from the trench, and removal and disposal of surplus excavation material, and all associated cost for licensed Geotechnical Engineer monitoring, analysis, and testing.

Payment for furnishing and installation of transition couplings shall not be made directly, costs for furnishing and installation of transition couplings shall be included in the Lump Sum for the various Connections to Existing Water Mains in the Proposal.

SECTION 302.14 - PLASTIC PIPE.

Add the following paragraphs to the “A. General” subsection:

The contractor shall furnish and install Polyvinyl Chloride (PVC) pipe for this project if required. All types and sizes of PVC pipes shall be AWWA C900, Pressure Class 200, DR14 pipe for pipes larger than 2 ½” or schedule 80 PVC pipe for sizes 2 1/2” and smaller.

Pipe cushion material as called for on the plans shall adhere to the requirements of “Water System Standards” Section 209.02, Pipe Cushion. When ground water is encountered or when required by the Engineer, the pipe cushion shall be wrapped in non-woven geotextile fabric in accordance with the “Water System Standards” Section 212.05, Geotextile Fabrics. The contractor shall retain the services of a licensed Geotechnical Engineer to monitor the quality of pipe cushion material, installation, and compaction of the pipe cushion, geotextile encasement, and trench backfill. The Department of Water will require periodic sieve testing of the pipe cushion material during the course of construction.

If PVC installation will be within State Highways Right-of-Way, installation, work, and materials used for this project shall comply with the requirements in Section 624 – Water System, Section 703.21 – Trench Backfill Material, Section 716 – Geotextiles, and Section 716.03 – Geotextiles for Underdrain Applications of the “Specifications for Road and Bridge Construction”, State of Hawai‘i, dated 2005, unless otherwise approved by the authoritative agency.

Transition couplings shall be Romac Style “501”, Style “RC501”, or approved equal. C-900 PVC to A.C. transition couplings shall be 14" in length.

Amend the first paragraph of the “B. Payment” subsection to read:

Payment for furnishing and installation of various sizes of PVC Pipe including all necessary joints accessories and fusion process and accompanying ground restraints, will be made at the respective Unit Price per linear foot based on the actual linear feet of PVC pipe installed (exclusive of valves, fittings, bends, and adapters), cleaned or pigged and successfully hydrotested in the field.

Add the following paragraphs to the “B. Payment” subsection:

The Unit Price for furnishing and installation of the various sizes of PVC Pipe shall be inclusive of trench excavation (without classification), trench backfill, pipe cushion, geotextile filter fabric encasement, conducting cable, warning tape, sheathing, removal and disposal of adobe, clay, mud, and other unsuitable material from the trench, removal and disposal of surplus excavation material, and all associated cost for licensed Geotechnical Engineer monitoring, analysis, and testing.

Payment for furnishing and installation of transition couplings shall not be made directly, costs for furnishing and installation of transition couplings shall be included in the Lump Sum for the various Connections to Existing Water Mains in the Proposal.

SECTION 302.15 - FITTINGS AND SPECIALS (DUCTILE IRON, CONCRETE CYLINDER, PLASTIC PVC PIPE).

Add the following paragraph to the “A.General” subsection:

The contractor shall furnish and install EBAA Iron Series 2000PV MEGALUG Mechanical Joint Restraint for plain end PVC pipe at all mechanical joint fittings and EBAA Iron Series 2100 MEGAFLANGE Restrained Flange Adapter for plain end PVC pipe at all flange joints. Both shall be installed in accordance with the manufacturer’s guidelines.

Amend the first paragraph of the “B. Payment” subsection to read:

Payment for furnishing and installing Cast Iron and Ductile Iron Fittings will be made at the Lump Sum Price, complete in place. The Contractor shall be responsible for the actual number of cast iron and ductile iron fittings furnished, installed and tested in the field. If a line item for Cast Iron and Ductile Iron fittings is not specifically provided, the contractor shall include the cost in the furnishing and installation of the waterline unit price.

Amend the fourth paragraph of the “B. Payment” subsection to read:

Payment for furnishing and installation PVC Fittings, including copper toning wire will not be paid for separately but shall be included in the Unit Price for furnishing and installation of the various sized PVC Pipes in the Proposal.

Amend the fifth paragraph of the “B. Payment” subsection to read:

Payment for furnishing and installation Flanged by Bell Adapters, Flanged Dismantling Joints, MEGALUG Mechanical Joint Restraint, and MEGAFLANGE Restrained Flange Adapters will not be paid for separately but shall be included in the Lump Sum Price for Cast Iron and Ductile Iron Fittings, in place complete.

#### SECTION 302.16- GATE VALVES AND BUTTERFLY VALVES.

Amend the first paragraph of the “A. General” subsection to read:

The contractor shall furnish and install all permanent and temporary gate valves and butterfly valves at locations shown on the plans or as directed by the Engineer. Unless otherwise specified, the installation shall be in accordance with the Standard Details. Specifications for furnishing and installing Temporary Gate Valves will comply with this section of the specification.

Amend the fourth paragraph of the “A. General” subsection to read:

Concrete anchor block with non-corrosive straps will not be required for this project.

Add the following paragraph to the “B. Payment” subsection:

The Unit Price for furnishing and installing Gate Valves and Butterfly Valves and furnishing and installing Temporary Gate Valves shall be inclusive of trench excavation (without classification), cast iron valve box, trench backfill, pipe cushion, warning tape,

sheathing and dewatering of trench, removal and disposal of adobe, clay, mud, and other unsuitable material from the trench, and removal and disposal of surplus excavation material.

SECTION 302.17 - AIR RELIEF VALVES.

Add the following paragraph to the “A. General” subsection:

Air relief valves shall be One-Inch Val-Matic Valve & Manufacturing Corp. Combination Air Valve 201C.2 with screened hood, or approved equal.

Amend the second paragraph of the “B. Payment” subsection to read:

The Unit Price for furnishing and installation of Air Relief Valve shall be full compensation for all labor, materials, tools and equipment for excavation (without classification) and backfill, sheathing and dewatering of trench, installation of copper pipes, fittings, various types of valves, ARV, cinder or crush rock cushion, brick saddle, ARV pipe stand, concrete footing, roofing felt, stainless steel straps, screened hood, paint, testing, and all other incidentals to complete this work.

SECTION 302.18 - SERVICE LATERALS, CONNECTIONS AND PIPES.

Add the following paragraphs under “A. General” subsection:

New service laterals shall be terminated with an angle valve in the existing meter boxes to facilitate the reconnection to the water meter.

Where existing meters are located within private properties, the new service lateral will be terminated within the public right-of-way and include a new Type “B” or Type “X” meter box with cast iron cover.

When a new lateral is being installed for an existing Department of Water consumer, the contractor shall furnish and install lateral piping including all fittings and appurtenances between the new meter and the existing consumer piping and perform reconnection work, and include a new meter box and cover.

When an existing lateral is being abandoned, the contractor shall cut and plug the existing lateral at the main. The existing meter box and cover shall be cleaned and transported to the Department’s Baseyard in Līhu‘e or Puhi, unless otherwise directed by the Engineer.

Amend the entire “D. Payment” subsection to read:

Payment covered under service laterals and connections and appurtenances shall be as follows: Payment for furnishing and installing various sizes of new service laterals and service connections, regardless of the lengths of the laterals or connections, will be made at the Unit Price per each unit based on the actual number installed and tested.

The Unit Price for furnishing and installing various sizes of new service laterals, service connections, and appurtenances shall be full compensation for all labor, materials, tools,

and equipment for all handling, hauling, unloading, placing, testing, and all other incidental necessary to complete the work.

No separate payment for the furnishing and installation of taps into mains, reconnections to existing consumer piping, temporary connections, cut and plug and removal of existing laterals, transferal of meters, pipes, fittings, ball corps, ball stops, angle valves, globe valves, double hub fittings, tapping tees, service saddles, meter boxes and covers, meter splices, brass pipes, caps, PVC conduits, warning tape, polyethylene wrap, plastic lateral for isolation, nor any other appurtenances will be made. Additionally, no separate payment will be for trench excavation (without classification) and backfill, sheathing and dewatering of trench, pipe cushion, nor transporting existing meter boxes and covers to the Department's Baseyard in Līhu'e or Puhi. The compensation for this work and items shall be deemed to be included in the Unit Price for New Service Laterals.

#### SECTION 302.19 – METER BOXES.

Amend the entire "B. Payment" subsection to read:

Payment for the furnishing and installation of meter boxes including frames and covers will not be paid for separately but shall be included in the Unit Price for Service Laterals or Air Relief Valve Assemblies.

Payment for the furnishing and installation of Meter Boxes shall be full compensation for all labor, materials, tools and equipment for all handling, hauling, unloading, placing, bricks, concrete, cast iron covers, painting, concrete slabs and all other incidentals necessary to complete the work.

No separate payment for excavation (without classification) and backfill of Meter Boxes will be made; the compensation for such work shall be deemed to be included in the Unit Price for Service Laterals or Air Relief Valve Assemblies.

#### SECTION 302.20 - FIRE HYDRANTS.

Amend the third paragraph of the "B. Payment" subsection into the following paragraphs:

Payment for excavation (without classification), backfill, sheathing and dewatering of trench, and fire hydrant markers will not be paid for separately but shall be included in the Unit Price for the furnishing and installation of Fire Hydrants.

No separate payment for the furnishing and installation of hydrant elbow, hydrant extension, pipe cushion, flat brick support, and all other appurtenances will be made; the compensation for such work shall be deemed to be included in the Unit Price for Fire Hydrants.

#### SECTION 302.21 - FIRE HYDRANT MARKERS.

Amend the first paragraph of the "B. Payment" subsection to read:

Payment for hydrant markers will not be paid for separately but shall be included in the Unit Price for the furnishing and installation of Fire Hydrants.

SECTION 302.22 - CONCRETE BLOCKS, JACKETS, BEAMS, CURB GUARDS FOR FIRE HYDRANTS AND METER BOXES, MANHOLE AND VALVE BOX COLLAR.

Amend the entire “B. Payment” subsection to read:

Payment for concrete reaction blocks, thrust beams, thrust blocks and test blocks will be made at the Unit Price per each either by specific Offer line item or as a portion within the furnishing and installation of waterline line item. The Unit Price for concrete reaction blocks, thrust beams, thrust blocks and test blocks shall be full compensation for all labor, materials, tools and equipment for all excavation (without classification), backfill, sheathing, dewatering, concrete, forms, tie wire and chairs, bracings, straps, structural struts, surface finishing, curing, mixing, hauling, furnishing and placing reinforcing steel, and all other incidental materials and work necessary to construct the concrete reaction block, thrust block or thrust beam, in place complete.

Payment for concrete jackets will be made at the Unit Price per linear feet of concrete jacket installed for the various sizes of pipe, regardless of pipe size either by specific Offer line item or as a portion within the furnishing and installation of waterline line item. The Unit Price for concrete jackets shall be full compensation for all labor, materials, tools and equipment for all excavation (without classification), backfill, sheathing, dewatering, concrete, forms, tie wire and chairs, bracings, straps, surface finishing, curing, mixing, hauling, furnishing and placing reinforcing steel, and all other incidental materials and work necessary to construct the concrete jackets in place complete.

Payment for concrete jackets for smaller utility conduits crossing the project’s waterlines shall not be made separately. Costs for furnishing and installation of concrete jackets, including miscellaneous items such as warning tapes, shall be deemed to be included in the Unit Price for furnishing and installation of the various sizes and types of pipes in the Proposal.

SECTION 302.24 - VALVE BOXES.

Amend the first paragraph of the “A. General” subsection to read:

Valve boxes for air relief valves, butterfly valves and cleanouts shall be installed in accordance with the Standard Details. Valve boxes for temporary and permanent gate valves shall be furnished and installed in conformance with Standard Detail V11 of the WATER SYSTEM STANDARDS or as defined on the construction drawing for this project. Valve boxes shall be installed 3 feet minimum clear from gutter, curbs, utilities and any structures. For this section, Valve Box specifications for Temporary and Permanent Gate Valves are identical.

Amend the entire “B Payment” subsection to read:

Payment for the furnishing and installing of valve boxes including cast iron frames and covers and adjusting valve boxes to the required grade will not be paid for separately but shall be included in the Unit Price for Gate Valves or Temporary Gate Valves or Tapping Valves or Cleanout assemblies.

Payment shall be full compensation for all labor, materials, tools and equipment for all excavation (without classification) and backfill, cast iron frames and covers, concrete settlement slab, reinforced concrete collar and leveling slab, standpipe (concrete, cast iron, ductile iron, or welded steel pipe), brick leveling course, crushed rock fill, pipe cushion, painting, general area clean up, and all other incidentals necessary to complete the work.

No separate payment for backfilling around valve boxes with black sand, sand or coral chips and for temporary backfill and additional excavation (without classification) to expose the risers after chlorination will be made; the compensation for such work shall be deemed to be included in the Unit Price for Gate Valves, Temporary Gate Valves, Tapping Valves, or Cleanout assemblies.

SECTION 302.30 – CONNECTIONS, RELOCATIONS & LOWERING OF WATER MAINS AND LATERALS.

Amend the first paragraph of the “A. General” subsection to read:

Whenever connections to, disconnections from, relocations to, or lowering of existing mains, service laterals, or hydrant laterals are required, the Contractor shall perform all work necessary for the installation of the new or temporary water facility or abandonment of the existing water facility, as shown on the plans, under the coordination of the Manager or his authorized representative.

Add the following paragraph under “A. General” subsection:

The contractor shall utilize temporary waterlines to provide continuous water service and fire protection to existing consumers, as needed.

For this project, Connections to Existing Water Main involve connecting to various types of pipe. The Contractor shall not saw or cut or damage existing asbestos cement pipe. Asbestos cement pipes, fittings, and appurtenances shall be removed at the nearest coupling. The Contractor shall remove and dispose of asbestos cement pipes, fittings, and appurtenances in accordance with Section 302.31.

Amend the entire “B. Payment” subsection to read:

Payment for Connection to Existing Water Main, Connection to Existing Service Lateral, or Connection to Existing Hydrant Lateral which may include the furnishing and installing of pipes, fittings, fire hydrants, gate valves, tapping sleeves and valves, service saddles, hub clamps and other appurtenant materials, will be included in the Lump Sum Price for Connection to Existing Water Main or in the Unit Price for Connection to Existing Service Lateral, Connection to Existing Hydrant Lateral, or temporary bypasses and disconnects.

The Lump Sum Price or Unit Price shall represent full compensation for furnishing all materials, labor, tools, equipment, and incidentals required for excavation (without classification), backfill, sheathing and dewatering of trench, relocating existing gate valves, connections, relocations, disconnections, removal, or lowering of the existing mains as called for on the plans and in accordance with these specifications and inclusive of all incidentals required to complete the work.

No separate payment for cutting, plugging, relocating existing main, lowering of existing mains, providing temporary water service (if necessary), providing temporary fire protection (if necessary), or abandoning of existing mains will be made; the compensation for such work shall be deemed to be included in the Lump Sum for Connections to Existing Water Main or in the Unit Price for Connection to Existing Service Lateral or Connection to Existing Hydrant Lateral.

No separate payment for installation of bypass lines including cutting, plugging and abandoning existing bypass lines will be made; the compensation for such work shall be deemed to be included in the Lump Sum for Connections to Existing Water Main or in the Unit Price for Service Lateral Connections or Connection to Existing Hydrant Lateral.

SECTION 302.31 – REMOVING OR DEMOLISHING, REINSTALLING OR RETURNING EXISTING PIPES AND APPURTENANCES.

Add the following paragraphs under “A. General” subsection:

The contractor shall be responsible for removal and disposal of existing pipes and appurtenances abandoned within the State and County Right-of-Way. Removal and disposal of pipes shall follow all applicable OSHA, HIOSH, State of Hawai‘i and Federal Regulations. Abatement personnel shall oversee removal and disposal, when required. Unless otherwise directed by the Manager, pipes and appurtenances shall become the property of the Contractor and shall be expeditiously removed from the construction site.

Care shall be exercised when removing and disposing of asbestos cement pipe and appurtenances. If the contractor causes the asbestos cement pipe or appurtenance to become friable, he will not be reimbursed for extra costs incurred to handle, containerize, transport, and dispose of the waste. Disposal of asbestos cement pipe and appurtenances shall be at an approved asbestos disposal site and all disposal related costs shall be borne by the contractor. Disposal of all hazardous materials shall be completed within 24 hours of removal from the water system and shall not be stored within the project site beyond the 24 hour period.

Temporary pipes, fittings, valves, cleanouts, valve boxes with frames and covers, and appurtenances that were installed to provide temporary water service and fire protection shall be salvaged, cleaned, and transported to the Department’s Baseyard in Līhu‘e or Puhi.

Amend the first paragraph of the “B. Payment” subsection to read:

Payment for the removal, cleaning, and transporting of existing fire hydrants, standpipes, cleanouts, and air relief valves will be made at the Unit Price per each unit, based on the



actual number removed and accepted by the Manager. If a specific Offer line item is not provided, the contractor shall incorporate the costs into the unit price of the furnishing and installation of the applicable waterline. The Unit Price includes full compensation for all labor, materials, tools, and equipment for removing, cleaning, plugging existing water mains, providing temporary water service, restoring disturbed area, and transporting salvaged fire hydrants, standpipes, air relief valves, and appurtenances to the Department's Baseyard in Līhu'e or Puhi.

Add the following paragraphs to the "B. Payment" subsection:

Payment for removal of existing gate and tapping valves will be made at the Unit Price per each unit, based on the actual number removed and accepted by the Manager. If a specific Offer line item is not provided, the contractor shall incorporate the costs into the unit price of the furnishing and installation of the applicable waterline. The Unit Price includes full compensation for all labor, materials, tools, and equipment for removing existing valve box components, removing concrete settlement slab, plugging of existing water mains, installing concrete and dirt backfilling, restoration of disturbed area, and cleaning and transporting the salvaged cast iron frames and covers to the Department's Baseyard in Līhu'e or Puhi.

Payment for removal of temporary gate valves and valve box components will be made at the Unit Price per each unit, based on the actual number removed and accepted by the Manager. If a specific Offer line item is not provided, the contractor shall incorporate the costs into the unit price of the furnishing and installation of the applicable waterline. The Unit Price includes full compensation for all labor, materials, tools, and equipment for removing the temporary gate valves and valve box components, removing concrete settlement slab, installing concrete and dirt backfill, restoration of disturbed area, and cleaning and transporting salvaged gate valves and cast iron frames and covers to the Department's Baseyard in Līhu'e or Puhi.

Payment for the removal of temporary pipes and fittings will be made at the Lump Sum or Unit Price for Removal Temporary Water Main. The Lump Sum or Unit Price includes full compensation for all labor, materials, tools, and equipment for excavating (without classification), sheathing, dewatering, disconnecting and removing the temporary pipe and fittings, backfill and restoration of disturbed area, and cleaning and transporting salvaged pipes and fittings to the Department's Baseyard in Līhu'e or Puhi.

Payment for the removal and disposal of existing pipes, fittings, and appurtenances within the State and County Right-of-Way will be made at the Lump Sum or Unit Price for Removal of Water Main. The Lump Sum or Unit Price shall be full compensation for all labor, materials, tools and equipment for excavating (without classification), sheathing, dewatering, disconnecting, removing, processing, storing, hauling, and disposing of abandoned pipes and fittings, backfill and restoration of disturbed area, abatement personnel, disposal and inspection fees, cutting and plugging of existing water mains and laterals, and all other incidental materials and work necessary for the complete removal of abandoned pipes, fittings, and appurtenances.

Payment for the removal and disposal of existing pipes and appurtenances not specified above shall be considered incidental and shall not be paid for separately but shall be included in the Unit Price or Lump Sum for the various items in the Offer. Payment shall

be full compensation for all labor, materials, tools and equipment for excavating (without classification), sheathing, dewatering, disconnecting, removing, hauling, storing, and disposing of abandoned pipes and fittings, backfilling and restoring disturbed area, disposal and inspection fees, cutting and plugging of existing water mains and laterals, and all other incidental materials and work necessary for the complete removal of abandoned pipes and appurtenances.

SECTION 302.35 - VALVE MARKERS.

Amend the entire “B Payment” subsection to read:

Payment for the furnishing and installation of Valve Markers will not be paid for separately, but shall be included in the Unit Price for the installation of various sized of gate or tapping valves. Payment shall be full compensation for all labor, materials, tools and equipment for all excavation (without classification), backfill, concrete, painting, and all other incidental materials and work necessary to complete the work.

SECTION 302.36 – SLOW CURING ASPHALT PAVEMENT (COLD MIX).

Amend “B. Payment”, replace the first paragraph with the following:

Payment for furnishing, placement, maintenance and removal of SLOW CURING ASPHALT (Cold Mix) shall be deemed to be included in the Unit Price for furnishing and installation of the various sizes and types of pipes in the Proposal.

SECTION 302.37 - RESTORING PAVEMENTS, DRIVEWAYS, SIDEWALKS, CURBS, GUTTERS, FENCES, WALLS, AND MISCELLANEOUS.

Add the following paragraphs under “A. General” subsection:

Asphalt concrete (A.C.) pavement resurfacing work shall include cold planing a 2-inch thick layer of existing A.C. pavement and resurfacing with a minimum 2-inch thick layer of new A.C. pavement (State Mix IV or V). Cold planing and resurfacing of A.C. pavement shall be in accordance with the Hawai‘i Standard Specifications for Road and Bridge Construction, 2005. The contractor shall construct the project per the approved construction drawings details and notes and verify potential AC thicknesses that could be encountered prior to submitting a Offer.

Existing pavement striping disturbed by this project shall be restored using thermoplastic extrusion. Painting is not acceptable. Installation of thermoplastic extrusion shall be in accordance with the Hawai‘i Standard Specifications for Road and Bridge Construction, 2005.

Existing reinforced concrete sidewalks, curbs, gutters, ramps, driveways, and swales disturbed by this project shall be restored to State Highways Standards in accordance with the Hawai‘i Standard Specifications for Road and Bridge Construction, 2005 and the Highway’s Division, Design Branch, Standard Plans, 2008.

Amend the entire “C. Payment” subsection to read:

Unless otherwise specified, payment for restoring fences, mail boxes, walls, landscaping, highway signs, highway markers and reflectors, and thermoplastic pavement striping shall not be measured nor paid for directly but shall be considered incidental to the construction work.

Payment for Restoring A.C. Pavement, inclusive of base and subbase courses, will be made at the Unit Price per square yard based on the minimum quantity required to be replaced on the approved plans, measured on the basis of the area of trenches specified for excavation plus an additional of twelve inches on each side of the trench for restoration within the State Right-of-Way or six inches on each side of the trench for restoration within the County Right-of-Way. The Unit Price shall be full compensation for all labor materials, tools, and equipment, for all handling, removing, placing, maintaining and all other incidental materials and work necessary to complete the Restoring A.C. Pavement work.

Payment for Cold Planing Existing A.C. Pavement and A.C. Pavement Resurfacing will each be made at the Unit Price per square yard based on the minimum quantities required as noted on the approved plans. Each Unit Price shall be full compensation for all labor materials, tools, and equipment, for all handling, removing, placing, maintaining and all other incidental materials and work necessary to complete the Cold Planing of Existing A.C. Pavement and A.C. Pavement Resurfacing work.

Payment for A.C. Pavement resurfacing, will be made at the Unit Price per square yard based on the minimum quantity required to be replaced on the approved plans, measured on the basis of the area of roadway required to be resurfaced within the State Right-of-Way or County Right-of-Way. The Unit Price shall be full compensation for all labor materials, tools, and equipment, for all handling, removing, placing, maintaining and all other incidental materials and work necessary to complete the A.C. Pavement resurfacing work.

Unless otherwise specified, payment for restoration of Reinforced Concrete Sidewalk, Curbs, and Ramps, Reinforced Concrete Driveway, AC Driveways and Reinforced Concrete Swale shall not be measured nor paid for directly but shall be considered incidental to the construction work. If specified as a Unit Price, the Unit Price shall be full compensation for all labor materials, tools, and equipment, for all handling, removing, placing, finishing, maintaining, installation of forms, steel or weld wire fabric reinforcement, base course, and all other incidental materials and work necessary to complete the restoration of Reinforced Concrete Sidewalk, Curbs, and Ramps, Reinforced Concrete Driveway, AC Driveway and Reinforced Concrete Swale work.

Add the Following Section:

SECTION 302.40 - BRACING OF UTILITY POLES.

When excavating close to utility poles, when specified on the plans, or when directed by the Manager, the Contractor shall brace the utility pole if the utility pole is owned by Hawaiian Telcom or pay for bracing if the utility pole is owned by Kaua'i Island Utility Cooperative (KIUC). In addition to "Bracing of Utility Poles", the utility agency(s) may require the contractor to stabilize the ground adjacent to the pole(s). "Bracing of Utility Poles" and stabilizing the ground adjacent to the utility pole(s) includes all labor,

materials, tools, and equipment necessary to install braces for existing utility poles, stabilize the ground adjacent to the utility poles, and for their removal when bracing and/or stabilizing are no longer necessary. Payment for bracing of utility poles or reimbursement for utility poles braced by KIUC or stabilizing the ground adjacent to the utility poles will not be made directly but shall be included in the Unit Price for the various items in the proposal.

Add the Following Section:

SECTION 302.41 – TRAFFIC CONTROL

Unless provided a specific line item in the Offer, Payment for traffic control work will not be made directly but shall be included in the Unit Price for the various items in the proposal.

SECTION 302.42 - REMOVING AND SALVAGING/DISPOSING OF MATERIALS.

Payment for removal and salvage or disposal of materials (fire hydrants, standpipes, valve boxes, etc.) and for the restoration of the area shall not be made directly; costs for these items of work shall be included in the unit price offer for the various items in the proposal.

Add the Following Section:

SECTION 302.43 – EROSION CONTROL / BMP

Payment for all erosion control / BMP measures shown on the drawings will not be made directly but shall be included in the Unit Price for waterline installation.

- 1.1.03 DEPARTMENT OF PUBLIC WORKS, COUNTY OF KAUA‘I STANDARD SPECIFICATIONS: Whenever reference is made within these Special Provisions or the contract plans to the DPW Standard Specifications, the specifications referred to is the “HAWAI‘I STANDARD SPECIFICATIONS FOR ROAD, BRIDGE, AND PUBLIC WORKS CONSTRUCTION” of the State of Hawai‘i, 2005, and all subsequent amendments. These specifications are not bound in these contract documents, but shall by reference be incorporated herein and made a part of these specifications.
- 1.1.04 DEPARTMENT OF PUBLIC WORKS, COUNTY OF KAUA‘I, STANDARD DETAILS: Whenever reference is made within these Special Provisions or the contract plans to the DPW Standard Details, the Details referred to is the “STANDARD DETAILS FOR PUBLIC WORKS CONSTRUCTION”, September 1984 and all subsequent amendments. The DPW Standard Details are not bound in these contract documents, but shall be incorporated herein and made a part of these specifications by reference.
- 1.1.05 SPECIAL DEFINITIONS: The following definitions shall apply unless the context indicates otherwise. Wherever the terms “Engineer” or “Owner” are used in any document which forms a part of this contract, they shall mean the Department of Water, County of Kaua‘i and its authorized agents.

- 1.2 PRECONSTRUCTION CONFERENCE: The Contractor shall arrange a preconstruction conference with the Project Manager, along with other affected agencies, firms and individuals within seven (7) days after all submittals have been approved by the Department of Water.

The Contractor shall submit a construction schedule to the Department of Water at the conference. This construction schedule shall be closely adhered to throughout the period of the contract.

At the preconstruction conference, the Contractor shall submit to the Department, the name of its authorized superintendent of the job.

The Contractor shall notify the Department at least three (3) working days prior to the start of construction.

- 1.3 CONTRACTOR'S RESPONSES BY HARDCOPY OR ELECTRONIC MAIL: The Contractor may respond in writing by submitting a hardcopy or by electronic mail only to the following Department's requests:

- A. Notice of Intention to Propose.
- B. Request for Clarification.
- C. Pre-Offer Due Date Modification or Withdrawal of Offers.

The hardcopy shall be submitted as specified in the applicable subsection and shall include the following information:

To : Manager & Chief Engineer  
Department of Water, County of Kaua'i

Attention : Dustin Moises

From :

Date :

Subject : (Subject)

---

**JOB NO. 17-10, WP2020 Project No. KW-07 Rehabilitate Paua Valley Tank No. 1, 0.5 MG Concrete Kekaha Water System  
KAUA'I, HAWAII**

- 1.4 FAILURE TO COMPLETE ON TIME AND LIQUIDATED DAMAGES: The Contractor shall complete the work within the number of calendar days specified in the contract. The specified number of calendar days shall commence from the date designated in the Notice to Proceed.

Completion of the work within the required time is important since delay in the prosecution of the work will inconvenience the public, obstruct traffic and interfere with business.

The Contractor understands and agrees that time is an essential factor of this Contract, and that the Department will suffer material loss by reason of delays that may occur in the Contractor's performance of the work or any portions of the work within the time or times fixed in this Contract or any extensions thereto. When the Contractor is given notice of delay or nonperformance, as specified in the Termination for Default clause of this Contract, and fails to cure in the time specified, the Contractor shall pay to the Department, as liquidated damages for any such delays, **\$One Thousand Dollars (\$1,000.00 )** for each and every calendar day of delay or nonperformance from the day set for cure until either the Department reasonably obtains similar Goods or Services if the Contractor is terminated for default, or until the Contractor provides the Goods or Services if the Contractor is not terminated for default. The sums of each and every calendar day of delay or nonperformance shall be deducted from the Contract price. It is expressly stipulated by and between the Contractor and the Department that any such sums shall be deemed and taken to be liquidated damages for the Contractor's failure to perform within the specified time or times and not be in the nature of a penalty. To the extent that the Contractor's delay or nonperformance is excused under the Termination for Default clause of this Contract, liquidated damages shall not be due the Department. The Contractor remains liable for all unexcused nonperformance or delay.

1.5 MEASUREMENTS: Figured dimensions and drawings take precedence over measurements by scale. The Contractor must verify all measurements at the site and be responsible for the accuracy of the same.

1.6 PROJECT RECORD DOCUMENTS:

1.6.01 SECTION INCLUDES: Overview of maintenance of documents, recording requirements, and submittal of Project Record Documents.

1.6.02 MAINTENANCE OF DOCUMENTS:

A. Maintain a record copy of the following Project Record Documents on-site and record actual revisions to the work:

- (1) Contract Drawings.
- (2) Specifications.
- (3) Amendments.
- (4) Change orders and other modifications to the Contract.
- (5) Reviewed submittals.
- (6) Permits. (Road, Building, Noise, NPDES, etc.)
- (7) Specified installer/tradesman certificates.
- (8) Update Revisions to BMP plans as required by NPDES permit(s).
- (9) Other Project Record Documents as indicated in specific Specification sections.

B. Store Project Record Documents apart from other documents. Provide separate files, racks, and secure storage for Project Record Documents.

C. Record information concurrent with construction progress.

- D. Label and file Project Record Documents in accordance with these Specifications. Label each document “PROJECT RECORD” in neat, large, printed letters.
- E. Maintain Project Record Documents in a clean, dry and legible condition.
- F. Keep Project Record Documents available for inspection.

1.6.03 RECORDING REQUIREMENTS:

- A. Use an erasable red pencil (not ink or indelible pencil) to clearly record information or changes on the Drawings by graphic line and note as required. Use an erasable yellow pencil to clearly mark for verification all major components shown as constructed.
- B. Use different colors for overlapping changes if required for clarification.
- C. Record information concurrently with construction progress. Do not conceal any work until required information is recorded. Date all entries reflecting change.
- D. Legibly mark each item on the Drawings to record actual construction, including:
  - (1) Measured horizontal and vertical locations of underground utilities and appurtenances, referenced to permanent surface improvements.
  - (2) Field changes of dimension and detail.
  - (3) Changes made by Contract amendments and modifications.
  - (4) Details not on original Drawings.
  - (5) References to related shop drawings.
- E. Specifications: Legibly mark each item to record actual construction, including the following:
  - (1) Manufacturer’s name and product model and number.
  - (2) Product substitutions or alternates utilized, as approved by DOW.
  - (3) Changes made by amendment and contract modifications.
- F. As-Built Drawings: The contractor shall provide and keep up-to-date a complete set of as-built prints for this project which shall be corrected regularly, showing every change from the original contract drawing set, including all addenda, change orders job decisions, etc. The as-built prints shall be used only as a record set and shall be kept on the job site available for the Department’s review.

At the time of the final inspection, the contractor shall furnish the Department with one hard copy set of the as built drawings for review. After DOW provides review comments to the contract, the contractor shall provide one hard copy Mylar set with

all original signatures and redline changes (**also CADD format and PDF format on CD or external drive**) showing all of the changes from the original contract set drawings including addenda, change orders, job decisions, etc. The “As-built Drawings” will be required to include the information stated in the General Provisions and prior to final acceptance as stated in the General Provisions. The “RECORD TRACINGS” block shall be utilized and signature blocks for the contractor, engineer and DOW Manager shall be provided on all sheets.

#### 1.6.04 SUBMITTALS:

- A. At the completion of construction, deliver Project Record Documents.
- B. Transmit the Project Record Documents with a cover letter listing.
  - (1) Date.
  - (2) Project title and number.
  - (3) Contractor’s name, address, and telephone number.
  - (4) Number and title of each Project Record Document.
  - (5) Signature of Contractor or authorized representative.

#### 1.7 SUBSTITUTIONS

- A. The materials or products specified herein by trade name shall be provided as specified. Notwithstanding any reference in the specifications to any article, device, product, material, fixture, form or type of construction by name, make or catalog number, such references shall be interpreted as establishing a standard of quality and shall not be construed as limiting competition. Brand names where used on the plans or in the specifications shall be presumed to be followed by the words “or approved equal.” Such approval will be granted only under the following conditions: Substitution of a brand other than specifically name in the contract documents will be approved by the Department of Water if it meets the following conditions:
  - 1. That it is equal or superior to the brand name in the specifications in construction, efficiency and utility.
  - 2. That it is equal or less in cost to the Owner.
  - 3. That during the construction period, the material or product specified cannot be delivered to the job in time to complete the work in proper sequence due to conditions beyond the control of the Contractor.
- B. To receive consideration, request for substitutions must be accompanied by documentary proof of the quality, difference in price and delivery, if any, in the form of certified quotations from suppliers of, both, specified and proposed materials or products. In case of a difference in price, the County shall receive all-benefit of the difference in cost involved by change order or credit the County with any savings so obtained.
- C. If substitution of any brand other than the one specifically named requires changes to work detailed or specified under other headings, then the Contractor assumes all responsibility for this work.



D. Substitution request must be received by said date in Section 1.9 “Substitute Materials” (Section 1-Administration, Page 20).

1.8 STORAGE, WORK ZONE, AND CONSTRUCTION ACCESS: Department of Water shall not assume the responsibility to approve proposed storage areas, work zones, and construction traffic pattern in and out of the project site. The Contractor shall be responsible for all additional NPDES permits, as well as, all updates to approved BMPs per NPDES permit approval requirements.

1.9 PRESERVATION OF PROPERTY: Due care shall be exercised to avoid injury to existing roadway improvements or facilities, utility facilities, adjacent property and roadside trees, shrubs and other plants that are not to be removed.

Roadside trees, shrubs and other plants that are not to be removed, and pole lines, fences, walls, signs, markers and monuments, buildings and structures, manholes and handholes, conduits, pipelines under or above ground, drain and sewer and water lines, all roadway facilities and any other improvements or facilities within or adjacent to the project shall be protected from injury or damage and if ordered by the Department of Water, the Contractor shall provide and install suitable safeguards, approved by the Department of Water, to protect such objects from injury or damage. If such objects are injured or damaged by reason of the Contractor’s operations, they shall be replaced or restored at the Contractor’s expense. The facilities shall be replaced or restored to a condition as good as when the Contractor entered upon the work, or as good as required by specifications accompanying the contract. The Department of Water may require the Contractor to make or cause to be made such temporary repairs borne by the Contractor and may be deducted from any moneys due or to become due to the Contractor under this contract. The fact that any underground facility is not shown upon the plans shall not relieve the Contractor of his or her responsibility. It shall be the Contractor’s responsibility to ascertain the existence of any underground improvements or facilities which may be subject to damage by reason of this operation.

Full compensation for furnishing all labor, materials, tools, equipment and incidentals, and for doing all the work involved in protecting or repairing property shall be considered as included in the prices paid for the various contract items of work and no additional compensation will be allowed.

1.10 EXTRA WORK: No work of any kind in connection with the work covered by these specifications and plans shall be considered as extra work, or entitles the Contractor to extra compensation, except when the work has been ordered in writing by the Department of Water prior to the performance of such work, and specifically referred to as EXTRA WORK and the amount of compensation stated in the change order.

1.11 BUILDING LAWS: The Contractor shall comply with the local laws, ordinances, rules, and regulations bearing on the work and he must obtain and pay for all permits, licenses, certificates and give all notices required thereby.

1.12 DELIVERY OF MATERIALS AT SITE: Have all materials delivered at the site in such quantities as will ensure the uninterrupted progress of the work and the least obstruction of the premises and the adjoining property.

- 1.13 DEFECTIVE MATERIALS: When requested, furnish, without charge, samples of all materials entering into the work. All materials not conforming to the requirements of these specifications shall be considered as defective and all such materials, whether in place or not, shall be rejected.
- 1.14 CLEAN UP: On the completion of each day's work during this construction project, the Contractor shall remove from the site all debris, tools and excess material resulting from the Contractor or the subcontractor's work and leave the work and any affected surrounding areas broom clean.
- 1.15 ENVIRONMENTAL PROTECTION: The Contractor shall comply with the requirements for pollution control in performing all construction activities as set forth in the General Provisions.
- 1.16 PROJECT SIGN: The Contractor shall furnish, erect, maintain and remove one (1) project sign. The project signboard shall be 3/4 inch thick "AC" exterior grade fir plywood, 4 feet in height and 8 feet long. Sign shall be painted with one prime coat and two finish coats. The sign layout detail and sign and post details shall be submitted to the Department for approval. The project sign shall be erected at the site designated by the Department of Water within seven (7) calendar days after approval of the sign layout. The Contractor shall apply and pay for all permits and fees required for the placement of the sign. The sign layout shall include the Department of Water's logo (graphic to be provided by the Department of Water) and the following information:

**REHABILITATE PAUA VALLEY TANK NO. 1, 0.5MG CONCRETE  
KEKAHA WATER SYSTEM IMPROVEMENTS  
JOB NO. 17-10  
WP2020 PROJECT NO. KW-07  
DEPARTMENT OF WATER**

1.17 SUBMITTALS:

1.17.01 SECTION INCLUDES: Overview of transmittal of submittals, submittals requirements, definition of submittal for review and definition of submittal for closeout.

1.17.02 RELATED SECTIONS: Section 1.6 Project Record Documents.

1.17.03 TRANSMITTAL OF SUBMITTALS:

A. General: Transmit submittals, number of copies as indicated in subsequent articles, to the following address:

Kaua'i Department of Water  
Attn: Dustin Moises  
4398 Pua Loke Street  
Līhu'e, Kaua'i, Hawai'i 96766

B. Submittals for Review: Transmit one (1) copy to the Department of Water for review. The Department will retain electronic set and return one (1) reviewed set. Should the contractor require more returned, he shall provide the additional sets at his or her cost. Where more copies are called for in any section of these Special

Provisions, the Contractor shall be required to submit said number of prints for approval.

Whenever possible, submittals/transmittals shall also be submitted electronically.

C. Submittals for Closeout:

(1) Operations and Maintenance Manuals:

- a. Preliminary Submittal: Transmit one (1) copy of manual to the Department of Water two (2) weeks prior to final inspection. This copy will be returned after final inspection, with comments.
- b. Final Submittal: Revise manuals and submit two (2) copies to the Department of Water two (2) weeks after receipt of comments to Preliminary Submittal.

(2) Project Record Documents: Submit Project Record Documents at the time of final inspection.

1.17.04 SUBMITTAL REQUIREMENTS:

A. Required submittals shall include:

- (1) Shop drawings.
- (2) Piping layout.
- (3) Manufacturer's Data.
- (4) Certificates of Warranty.
- (5) Any others as called for in the plans, specifications, or by the Engineer.

B. The Contractor's stamp and verification of drawings shall consist of the following information:

CONTRACTOR NAME

PROJECT: **Rehabilitate Paua Valley Tank No. 1, 0.5 MG Concrete Kekaha Water System**

JOB NO.: **17-10, WP2020 Project No. KW-07**

THIS SUBMITTAL HAS BEEN CHECKED BY THIS GENERAL CONTRACTOR. IT IS CERTIFIED CORRECT, AND IN COMPLIANCE WITH CONTRACT DRAWINGS AND SPECIFICATIONS. ALL AFFECTED CONTRACTORS AND SUPPLIERS ARE AWARE OF, AND WILL INTEGRATE THIS SUBMITTAL INTO THEIR OWN WORK.

DATE RECEIVED: \_\_\_\_\_

SUBMITTAL NUMBER: \_\_\_\_\_

SPECIFICATION SECTION: \_\_\_\_\_

SPECIFICATION PARAGRAPH: \_\_\_\_\_  
DRAWING NUMBER: \_\_\_\_\_  
SUBCONTRACTOR NAME: \_\_\_\_\_  
SUPPLIER NAME: \_\_\_\_\_  
MANUFACTURER NAME: \_\_\_\_\_  
CERTIFIED BY: \_\_\_\_\_

- C. This stamp, “filled in”, should appear on the title sheet of each shop drawing, on a cover sheet of submittals in an 8½"x11" format, or on a one face of a cardstock tag (min. 3"x6") tied to each sample. The tag on samples should state what the sample is, so that, if the tag is accidentally separated from the sample, it can be matched up again.
- D. The person signing the Contractor’s submittal stamp shall be the person with authority to act for the Contractor in connection with the contract during the performance of the contract. The signature shall be in original ink. Stamped signature will not be acceptable.
- E. Prepare submittals to show that the material, equipment, or work shown is in accordance with contract requirements and has been checked for dimensions and relationship with work of all other trades involved. All deviations from the plans and specifications shall be noted.
- F. Approval shall extend only to general conformance and shall not relieve the Contractor from his or her responsibility for coordinating his or her work with other trades and complying with the provisions of the contract documents for lengths, fits, quality of materials, quantities, applicable code requirements and other details. Approval does not authorize changes from the contract requirements unless stated in a separate letter or change order.
- G. Submittals shall be made in sufficient time to allow the Engineer not less than twenty regular working days for examining the drawings. The Contractor shall make submittals at the earliest possible date after the Notice to Proceed date to meet the construction schedule. The Engineer will not consider delays caused by the Contractor’s failure to make submittals on time as justifiable reasons for contract time extensions.
- H. When the submittals have been reviewed by the Engineer, two sets of submittals will be returned to the Contractor appropriately stamped. If major changes or corrections are necessary, the submittal may be rejected and one set will be returned to the Contractor with such changes or corrections indicated, and the Contractor shall correct and resubmit six copies of the drawings, unless otherwise directed by the Engineer. No changes shall be made by the Contractor to the resubmitted shop drawings other than those changes indicated by the Engineer. The resubmittal shall be so indicated on the shop drawing.
- I. Prior to approval of such drawings, any work which the Contractor may do on fabrications covered by the same is at his or her own risk, as the County will not be responsible for any expense incurred by the Contractor for changes to make the same conform to the drawings as finally approved.

J. Upon approval of the above drawings, lists, prints and other data, a copy of the same shall be kept with the job site plans, and the fabrications furnished shall be in conformance with the same. However, approval of above drawings, lists, prints, specifications and other data shall in no way release the Contractor from his or her responsibility for the proper fulfillment of the requirements of this contract nor for fulfilling the purpose of the installation nor from his or her liability to replace the same should it prove defective or fail to meet the specified requirements.

K. Submittal Clarity:

(1) Drawings:

- a. Prepare finished drawings so that prints, reproducible, and reductions to half size will be clear and legible.
- b. Make free-hand lettering no less than 5/32 inch high and typewritten notes no less than 1/8 inch high to allow for reduction. Do not crowd lettering.

(2) Manufacturer's Literature:

- a. Submit a minimum of one original of manufacturer's printed material. Remaining number of submittals may be reproductions. Ensure reproductions of original materials are clear and legible.
- b. Clearly mark the item(s) and/or information applicable to this project with arrows, bubbles, etc. Do not use high-lighted markings.
- c. Provide the name and phone number of manufacturer's sales and service representative for each device submitted.

1.17.05 DEFINITION OF "SUBMITTALS FOR REVIEW":

- A. Catalog Data: Manufacturer's standard printed information on materials, products and systems, which shows performance characteristics, dimensions, material of fabrication, and other characteristics necessary to assure conformity with the design requirements. Where other items or information not related to the work of this project are included in the literature submitted, the item(s) and/or information applicable to this project shall be clearly marked.
- B. Shop Drawings: Drawings necessary to show fabrication details to ensure compliance with contract documents.
- C. Block Diagrams: Block Diagrams necessary to show system connections and details to ensure compliance with contract documents.
- D. Wiring Diagrams: Drawings showing the point-to-point or schematic wiring of a piece of equipment or between pieces of equipment in a system.
- E. Calculations: The methods and results of calculations in documented form where specified.

- F. Material / Parts List: A list of system components or material components.
- G. Samples / Colors: Samples, including colors, of proposed materials.
- H. Certifications: A written statement, signed by a qualified party, attesting that items or services are in accordance with specified requirements. Typically, this written statement is accompanied by additional information to substantiate the statement.
- I. Installation Instructions / Test Procedures: Manufacturer's instructions, step-by-step if necessary, showing the field installation and testing of parts, components, equipment, and other similar items.
- J. Test Reports: Results of specified test requirements.
- K. Meetings: Schedule, agenda, attendees, and location for required meetings and meeting notes.
- L. Other: Other submittal information as described in individual specification sections.

1.17.06 DEFINITION OF "SUBMITTALS FOR CLOSEOUT":

A. Operations and Maintenance (O&M) Manuals:

(1) Format:

a. Hardcopy: Three (3) full sets

- 1) Size: 8½"x11". Fold 11"x17" drawings to 8½"x11" size. Reduce drawings larger than 11"x17" format to 11"x17" format.
- 2) Binders: Use commercial quality expandable post binders meeting the following requirements:
  - (a) Binder Covers: 1/8" thick construction (minimum).
  - (b) Hinges: Continuous, metal piano hinge.
  - (c) Binder Expandability: 3½" – 5½".
  - (d) Sheet Size: 8½"x11".
  - (e) Binder Cover Material: Heavy vinyl.
  - (f) Binder Printing: Provide custom printed spine and front imprinted with the following information:

County of Kaua'i  
 Department of Water  
 (Print O&M manual titles and project title)

(g) Manufacturer's Reference: Specialty Loose Leaf, Inc.

- 3) Fill: Do not fill binders more than 75% full.
  - 4) Indexed Tabs: Internally subdivide the binder contents with permanent page dividers, logically organized, with tab titling clearly printed under reinforced laminated plastic tabs.
- b. Adobe PDF Electronic Copy: Provide a copy of the O&M Manual in Adobe PDF Electronic Format on compact disk(s).
  - c. Electronic Data: Provide electronic files on compact disk(s) of any material created electronically by Integrator, in file format in which document was created, that is, Microsoft Word, AutoCAD, etc., including but not limited to:
    - 1) Drawing Files.
    - 2) Installation Instructions.
    - 3) Software Documentation.
    - 4) Operating and Maintenance Instructions.
  - d. Odd Sized Material: Where O&M information does not lend itself to incorporation into 8½"x11" format, such as the material listed, below, provide it separate from the O&M Manuals. However, clearly label each item, and provide reference in the O&M Manual to the material that is provided separate from the O&M Manuals.
    - 1) Edge-glued books or manuals without 3-hole punched binding.
    - 2) Material of a size other than 8½"x11".
    - 3) Compact disks in jewel cases.

(2) Contents:

- a. Table of Contents: Prepare a Table of Contents, for each volume, with each product or system description identified, and include with each volume of manual. Type on 24-pound white paper.
- b. Directory: Provide names, addresses, and telephone number of Prime Contractor, Integrator, Installation Contractor, other subcontractors, and major equipment suppliers. Clearly identify contact for warranty support.
- c. General: Provide operations and maintenance data for equipment described in the individual sections of the Specification. Prepare and include additional data when the need for such data becomes apparent during training.
- d. Description of System and Component Parts:
  - 1) System block and interconnection diagrams.

- 2) Control diagrams by controls vendor and as-installed control drawing by Contractor.
  - 3) As-installed wiring diagrams, that is, ladder diagrams, point to point diagrams, loop diagrams, circuit directories of panel boards, and similar items.
  - 4) Manufacturer's printed installation, operating, and maintenance instructions for the exact item of equipment supplied.
  - 5) Catalog data containing information required for service, future additions or substitutions.
  - 6) Function, normal operating characteristics, and limiting conditions.
  - 7) Performance curves, engineering data and tests.
  - 8) Complete nomenclature and commercial number of replaceable parts.
- e. System Operating Procedures:
- 1) Description of sequence of operation by control manufacturer.
  - 2) Routine and normal operating instructions.
  - 3) Sequences required.
  - 4) Special operating instructions.
- f. System and Equipment Maintenance Procedures:
- 1) Routine operations.
  - 2) Guide to "trouble-shooting"
  - 3) Disassembly, repair and reassembly.
  - 4) Alignment, adjusting and checking.
- g. Maintenance instructions for special finishes, including recommended cleaning methods and materials and special precautions identifying detrimental agents.
- h. Spare Parts List: List of manufacturer's spare parts provided with the job, manufacturer's current prices for spare parts, and recommended quantities to be maintained in storage.
- B. Project Record Documents: Provide Project Record Documents as required.
- C. Spare Parts / Maintenance Materials:
- (1) Provide products, spare parts, maintenance and extra materials in quantities specified in individual specification sections prior to Final Acceptance.
  - (2) Deliver to Project site and place in location as directed by the Department of Water. Contractor shall obtain receipt.



D. Test Reports: Results of specified test requirements. Provide Table of Contents of test results and incorporate into Operation and Maintenance Manuals described above.

E. Warranty Certificates:

(1) For each item required by specific sections of this specification, provide a notarized warranty certificate.

(2) Execute and assemble documents from subcontractors, suppliers, and manufacturer.

(3) For each item of copyrighted software provide under this contract, provide a software license certificate naming the Department of Water as the licensee and stating the number of licenses provided.

(4) Provide Table of Contents of software licenses and incorporate into Operation and Maintenance Manuals described above.

1.18 CONTRACTOR'S OPERATIONS: The Contractor must employ, insofar as possible, such methods and means of carrying out his work so as not to cause any interruption or interference to the Department of Water's or the landowner's operations. Where the Contractor's operations would result in interruptions which would hamper the operations, the Contractor shall coordinate his schedule of work with the Department of Water or the landowner, accordingly.

In the event that the Contractor obtains permission from the landowner for use of any area or resources outside of the designated lot(s), County Right-of-Way, State Highway's Right-of-Way, and/or designated easement(s), the Contractor shall meet the requirements of Division 300, Section 301.15 – USE AND/OR DAMAGE TO PRIVATE PROPERTY (PROPERTY OWNED OTHER THAN BY THE CONTRACTOR) of the Water System Standards, 2002.

END OF SECTION

SECTION SP-2 – EXISTING CONDITIONS – ASBESTOS / LEAD / HAZARDOUS MATERIAL SURVEY

A. GENERAL PROJECT DESCRIPTION

This Section includes hazardous material survey data for asbestos-containing materials, lead paints, and Polychlorinated Biphenyls (PCB)-containing surface coating, for the Rehabilitate Paua Valley Tank No. 1, 0.5 MG Concrete Project, for the County of Kauai Department of Water, Kekaha Water System, Island of Kauai.

1. Related Sections:

- a) SECTION SP 3 - REMOVAL AND DISPOSAL OF MATERIAL CONTAINING ASBESTOS for requirements of work which disturbs materials containing asbestos.
- b) SECTION SP 4 - LEAD HAZARD CONTROL for requirements of work which disturbs lead-containing paints.
- c) SECTION SP 5 - REMOVAL AND DISPOSAL OF BULK MATERIAL CONTAINING PCB for requirements of work which disturbs materials which contain polychlorinated biphenyls (PCB).
- d) SECTION SP 6 - TESTING/AIR MONITORING for requirements for monitoring and clearance for compliance.

B. ASBESTOS

1. Existing Conditions: The structure to be renovated or modified under this contract was surveyed for the presence of asbestos. Asbestos outside of the project area shall not be disturbed in any way.
2. Personnel Notifications: Notify employees, subcontractors, and all other persons engaged on the project of the presence of asbestos in the existing tank in accordance with the requirements of Chapter 110, Article 12-110-2 (f) (1) (B) of the Occupational Safety and Health Standards, State of Hawaii.
3. In the event that work is required in any structures other than the one(s) designated within this project scope, request a copy of the hazardous material survey report(s) from the County of Kauai Department of Water (DOW). Based on the information contained in the survey(s), notify affected personnel per paragraph above.
4. Regulatory Compliance: Contractor shall follow applicable Federal and State rules and regulations pertaining to the handling, removal, and disposal of building materials with hazardous components. All work shall be conducted in a manner protective of the site workers, facility users, the public, and the environment.

C. LEAD CONTAINING PAINT

- A. Existing Conditions: Review the lead testing data which identify locations where lead paints were found. Lead testing was for design purposes only, and the results do not satisfy any of the requirements of Chapter 12-148 LEAD EXPOSURE IN CONSTRUCTION.

- B. Personnel Notification: Inform employees, subcontractors, and other persons engaged in the project that lead containing paints (LCP) is present in the existing tank and at the job site. Follow the requirements of Hawaii Administrative Rules Title 12 (Department of Labor and Industrial Relations, Subtitle 8 (Division of Occupational Safety and Health), Chapter 148.
  - C. Testing by Contractor: Contractor may conduct additional lead testing of existing painted surfaces at his/her own expense. In an absence of testing data, Contractor shall assume the paint contains lead and take appropriate engineering controls to minimize human and environmental exposures to lead.
  - D. Regulatory Compliance: Contractor shall follow applicable rules and regulations pertaining to the handling, removal, and disposal of lead paint and lead-containing waste.
- D. PCB COATING
- (1) Existing Conditions: Review the PCB bulk data, which identify concentrations and locations where PCB coating was found. The stored water contains detectable levels of PCB. The water shall be removed and disposed of appropriately per requirements in SP-13.
  - (2) Personnel Notification: Inform employees, subcontractors, and other persons engaged in the project that PCB is present in the existing tank.
  - (3) Regulatory Compliance: Contractor shall follow applicable rules and regulations pertaining to the handling, removal, and disposal of PCB-containing coating and water. Remove and dispose of the water appropriately per requirements in SP-13. All appropriate engineering controls, including dust control, runoff control, and or BMP, shall be implemented to prevent exposures to human and the environment, and to avoid visible emission of hazardous materials outside of the control areas.
- E. PART 2 - PRODUCTS
- Not applicable.
- F. PART 3 - EXECUTION
- G. HAZARDOUS MATERIAL SURVEY AND SUPPORTING DOCUMENTS
- A. Survey Report: *Hazardous Material Survey Report for Repairs to Kekaha 0.5 MG Concrete Storage Tank County of Kauai Department of Water Kekaha Water System, Kekaha, Island of Kauai*, 58 pages, dated December 14, 2017, prepared by Myounghee Noh & Associates, L.L.C.
  - B. USEPA Conditional Approval of PCB Cleanup Plan under TSCA 761.61(c) for Paua Valley Tank #1, Kekaha, Kauai, Hawaii, dated October 16, 2018
  - C. TSCA Risk-Based PCB Cleanup Approval Application, Department of Water, Rehabilitate Paua Valley Tank #1, Kekaha, Kauai, Hawaii, dated September 18, 2018
  - D. CONTRACTOR REVIEW OF SURVEY REPORT AND SUPPORTING DOCUMENTS. Contractor shall review existing survey report(s) and shall verify and understand the locations and volumes of hazardous materials. Contractor shall comply with the project requirements stated Supporting Documents, USEPA Conditional

Approval of PCB Cleanup Plan and TSCA Risk-Based PCB Cleanup Approval Application.

END OF SECTION

## SECTION SP-3 – REMOVAL AND DISPOSAL OF MATERIAL CONTAINING ASBESTOS

### a. GENERAL PROJECT DESCRIPTION

This Section specifies Contractor requirements when disturbing materials containing trace asbestos. Contractor shall refer to the survey data and verify the locations and quantities of asbestos that will be disturbed as part of the planned tank repair and related activities. Contractor shall ensure that employees and subcontractors involved in disturbing or removing hazardous materials have access to the survey report and the specifications, and understand and control asbestos hazards.

- a. Trace asbestos was confirmed in the project area as follows: Cement material under, and excluding beige coating, on the interior of the tank floor.
- b. Trace asbestos is not classified as regulated material; however, it remains an exposure concern for workers, particularly in an enclosed space. For the purpose of this project, applicable rules and regulations pertaining to the protection of workers, under OSHA and EPA rules shall apply.

### b. REFERENCES

- a. Publications: Publications are referred to in the text by the basic designation only. Federal requirements which govern asbestos abatement work, hauling and disposal of asbestos waste materials include, but are not limited to, the following:

#### A. OCCUPATIONAL SAFETY AND HEALTH ADMINISTRATION (OSHA): Requirement for worker protection include, but is not limited to:

1. Occupational Exposure to Asbestos, Tremolite, Anthophyllite, and Actinolite; Final Rules - Title 29, Part 1910, Section 1001 and Title 29, Part 1926, Section 1101 of the Code of Federal Regulations
2. Respiratory Protection; Title 29, Part 1910, Section 134 of the Code of Federal Regulations
3. Access to Employee Exposure and Medical Records; Title 29, Part 1910, Section 2 of the Code of Federal Regulations
4. Hazard Communication; Title 29, Part 1910, Section 1200 of the Code of Federal Regulations
5. Specifications for Accident Prevention Signs and Tags; Title 29, Part 1910, Section 145 of the Code of Federal Regulations

#### B. U.S. DEPARTMENT OF TRANSPORTATION (DOT): Requirements which govern the transportation of asbestos waste on DOT roads and highways include, but not limited to:

Hazardous Substances; Title 29, Parts 171 & 172 of the Code of Federal Regulations.

- C. U.S. ENVIRONMENTAL PROTECTION AGENCY (EPA): Requirements which govern asbestos abatement work, hauling, and disposal of asbestos waste materials include, but not limited to:
  - a. Asbestos Abatement Projects; Worker Protection Rule Title 40 Part 763, Sub-part G of the Code of Federal Regulations (CFR)
  - b. National Emission Standard for Hazardous Air Pollutants (NESHAP) National Emission Standard for Asbestos 40 CFR 61, Sub-part A, and Sub-part M (Revised Sub-part B)
- D. STATE OF HAWAII: Requirements which govern asbestos abatement work or hauling and disposal of asbestos waste materials include, but not limited to, the following:
  - A. HAR – Asbestos Requirements – Title 11, Chapter 501
  - B. HAR – Fees For Asbestos Removal And Certification – Title 11, Chapter 503
  - C. HAR – Asbestos Abatement Certification Program – Title 11, Chapter 504
- E. LOCAL REQUIREMENTS: Comply with applicable local requirements which govern asbestos abatement work and hauling and disposal of asbestos waste.

c. STANDARDS

- A. Applicable Standards: Standards which apply to asbestos abatement work or hauling and disposal of asbestos waste include, but not limited to, the following:
  - A. AMERICAN NATIONAL STANDARDS INSTITUTE (ANSI): Broadway, New York, New York 10018
    - a. Fundamentals Governing the Design and Operation of Local Exhaust Systems Publication Z9.2-2012
    - b. Practices for Respiratory Protection Publication Z88.2-2015
  - B. ASTM INTERNATIONAL: Race Street, Philadelphia, PA 19103
    - Standard Practice for Visual Inspection of Asbestos Abatement Projects E1368-2014

d. DEFINITIONS

- A. Amended Water: Water containing a wetting agent or surfactant.
- B. Area Monitoring: Sampling of asbestos fiber concentrations within the asbestos control area and outside the asbestos control area, which is representative of the airborne concentrations of asbestos fibers which may reach the breathing zone of personnel potentially exposed to asbestos.

- C. Asbestos: A group of naturally occurring minerals that separate into fibers. There are six asbestos minerals used commercially: chrysotile, amosite, crocidolite, tremolite, anthophyllite, and actinolite.
- D. Asbestos Control Area: An area where asbestos removal operations are performed which is isolated by physical boundaries to prevent unauthorized entry of personnel and to prevent the spread of asbestos dust, fibers, or debris.
- E. Asbestos Fibers: Asbestos fibers having a length to diameter ratio of at least 3:1 and longer than 5 micrometers.
- F. Asbestos Permissible Exposure Limit: The limit is 0.1 fibers (longer than 5 micrometers) per cubic centimeter of air as an 8-hour time weighted average as determined by Appendix A of 29 CFR 1926.1101.
- G. Friable Asbestos Material: Material that contains asbestos which can be crumbled, pulverized, or reduced to powder by hand pressure when dry. Friable asbestos is considered hazardous during removal and disposal procedures.
- H. HEPA Filter Equipment: High Efficiency Particulate Air (HEPA) filtered vacuuming equipment with a UL 586 filter system capable of collecting and retaining asbestos fibers. Filters shall be 99.97 percent efficiency for retaining fibers of 0.3 micrometers or larger.
- I. Industrial Hygienist (IH): A third party industrial hygiene professional, retained by the General Contractor to oversee the compliance. The onsite work can be performed by an industrial hygiene technician (IHT). The IHT shall have a valid Project Monitor certification from the Hawaii Department of Health, and shall be under the supervision of the industrial hygienist.
- J. Local Exhaust System: A system in which static pressure in an enclosed control area is lower than that of the environment outside the control area, as specified herein.
- K. Nonfriable Asbestos Material: Material that contain asbestos in which the fibers have been locked in by a bonding agent, coating, binder, or other material so that the asbestos is well bound and may not release fibers in excess of the asbestos permissible exposure limit during any appropriate use, handling, storing, transporting, or processing. Nonfriable asbestos material may become friable and hazardous during removal and disposal procedures.
- L. Personal Monitoring: Sampling of asbestos fiber concentrations within the breathing zone of an employee to determine the 8-hour time weighted average in accordance with Appendix A of 29 CFR 1926.1101. The samples shall be representative of the employee's work tasks. The breathing zone shall be considered an area within 12 inches of the nose or mouth of an employee.
- M. Removal Encapsulant: A manufactured asbestos penetrating encapsulant designed specifically for asbestos removal.
- N. Surfactant (Wetting Agent): A chemical wetting agent added to water to improve penetration. The surfactant shall be 50/50 mixture of polyoxyethylene ether and polyoxyethylene ester, or equivalent, mixed in a proportion of one fluid ounce to 5

gallons of water or as specified by the manufacturer. An equivalent surfactant shall be understood to mean material with a surface tension of 29 dynes/cm, as tested in accordance with ASTM D 1331.

- O. Time Weighted Average (TWA): TWA is an 8-hour time weighted average of airborne concentration of fibers (longer than 5 micrometers) per cubic centimeter of air which represents the employee's 8-hour workday as determined by Appendix A of 29 CFR 1926.1101.

e. ASESTOS REMOVAL

Total abatement of asbestos is anticipated. Asbestos work under this project generally includes materials that will be disturbed as part of this tank repair project and identified in the survey report. Removal or encapsulation of asbestos shall be conducted prior to removal or renovation of non-asbestos materials. Asbestos material removal and disposal is governed by 40 CFR 61, Subpart M, NESHAP.

f. SUBMITTALS

- 1. Submittal to be Approved by the County of Kauai Department of Water (DOW):  
Submittals shall be approved prior to commencing work involving asbestos materials.
  - 1. Asbestos Plan: Submit a detailed job-specific plan of the work procedures that will minimize airborne dust, which shall be employed in the removal of materials containing asbestos.
  - 2. Plan shall include:
    - 6. A clear scope of work for the Abatement Contractor
    - 7. Interface of trades involved in the construction
    - 8. Sequencing of asbestos-related work and other trades
    - 9. Disposal plan for hazardous and non-hazardous waste
    - 10. Type of wetting agent or removal encapsulant to be used
    - 11. Product specifications and Safety Data Sheets (SDS)
    - 12. Written Respiratory Protection Program
    - 13. Written Hazard Communication Program (HAZCOM)
    - 14. Current, valid training records for personnel who will conduct asbestos disturbance activities.
    - 15. Respirator fit test records
    - 16. Respirators and protective equipment



17. A detailed description of the methods to be employed in order to control exposures and pollution
  18. Emergency Procedures plan
  19. A sketch showing the location, size, and details of asbestos control areas, including clean and dirty areas, buffer zones, shower, storage areas, change rooms, 3-stage decontamination chamber, and removal methods.
3. Plan Approval: Prior to beginning work, Contractor shall meet with the DOW representative to discuss in detail the asbestos plan, including notifications, work procedures, and safety precautions.
  4. Landfill: Submit written evidence that the landfill is approved for asbestos disposal by the State and local regulatory agencies. Within 3 working days after delivery, submit Hazardous Waste Manifest Form, prepared, signed, and dated by an agent of the landfill, certifying the amount of asbestos materials delivered to the landfill.
  5. Respiratory Protection Program per ANSI Z88.2 and 29 CFR 1910.134. Contractor shall submit a list of workers who are respirator-qualified. Information shall also include date and type of fit testing and manufacturer and size of respirator.
  6. Permits, Licenses, and Certificates: Submit a copy of permits, licenses, certifications, inspection reports, releases, jurisdictional settlements, notices, receipts for fee payments, judgments, and similar documents, correspondence and records established in conjunction with compliance with standards and regulations bearing upon performance of the work including:
    - a. Notices: Submit notices required by Federal, State, and local regulations with proof of timely transmittal to agency requiring the notice.
    - b. Permits: Submit a copy of current valid permits required by State and local regulations.
    - c. Licenses: Submit a copy of State and local licenses necessary to carry out the work of this contract.

g. NOTICES

1. Notifications: Send a written courtesy notification to the State prior to beginning any work on trace asbestos to the following:

Indoor and Radiological Health Branch  
 State of Hawaii Asbestos Program  
 99-945 Halawa Valley Street  
 Aiea, HI 96701  
 Tel: (808) 586-5800

- a. Notification Requirements: Include the following information in the notification sent to the NESHAP contact:
  - a. Indication of whether notification is original or a revised notification.
  - b. Name and address of facility and operator and asbestos removal or operator.
  - c. Description of the facility being renovated, including the size, age, and present and prior use of the facility.
  - d. Type of operation: abatement or renovation
  - e. Estimate of the approximate amount of asbestos material to be removed from surface areas within the facility. For facilities in which the amount of asbestos material is less than 80 linear meters (260 linear feet) on pipes and less than 15 square meters (160 square feet) on other facility components, explain techniques of estimation.
  - f. Procedure and analytical methods used to detect the presence of asbestos.
  - g. Location of the facility being demolished or renovated (street address, room numbers, etc.)
  - h. Scheduled start and completion dates of abatement or renovation and any preparatory work that would disturb asbestos.
  - i. Nature of planned abatement or renovation and method(s) to be used.
  - j. Description of work practices and engineering controls.
  - k. Procedures to be used to comply with the requirements of USEPA National Emission Standards for Hazardous Air Pollutants (NESHAP) Asbestos Regulations (40 CFR 61 Subpart M).
  - l. Name, telephone and address of waste transporter.
  - m. Name and location of the waste disposal site where the friable asbestos waste material will be deposited.
  - n. Certification that at least one person trained as required by NESHAP will supervise the operation.
  - o. For facilities being demolished under an order of a State or local governmental agency, issued because the facility is structurally unsound and in danger of imminent collapse, the name, title, and authority of the State or local governmental agency, who has ordered the abatement, date the order was issued, and date on which abatement was to begin. Attach a copy of the order.
  - p. Other requirements per NESHAP.

h. PERMITS AND LICENSES

Obtain and maintain current permits and licenses as required by applicable federal, state or local jurisdictions for the removal, transporting, disposal or other regulated activity relative to the work of this contract.

i. POSTING AND FILING OF REGULATIONS

Post notices required by applicable Federal, State and local regulations. Maintain at least one (1) copy of applicable Federal, State, and local regulations and standards and approved work plan.

j. PART 2 - PRODUCTS

k. WETTING MATERIALS

a. Asbestos Wetting: For wetting prior to disturbance of materials containing asbestos, use either amended water or a removal encapsulant:

1. Amended Water: Provide water to which a surfactant has been added. Use a mixture of surfactant and water which results in wetting of the asbestos materials and retardation of fiber release during disturbance of the material equal to or greater than that provided by the use of one ounce of a surfactant consisting of 50% polyoxyethylene ester and 50% polyoxyethylene ether mixed with five gallons of water.
2. Removal Encapsulant: Provide a penetrating type encapsulant designed specifically for removal of Asbestos Material. A surfactant specified in the above paragraph may be used.

l. POLYETHYLENE SHEET

Provide a single polyethylene film in the largest sheet size possible to minimize seams, 6 mils thick, clear or frosted

m. DUCT TAPE

Provide duct tape in 2" or a 3" width as appropriate, with an adhesive, which is formulated to stick aggressively to sheet polyethylene.

n. SPRAY ADHESIVE

Provide spray adhesive in aerosol cans which is specifically formulated to stick tenaciously to sheet polyethylene.

o. DISPOSAL BAGS

Provide 6 mil thick leak-tight polyethylene bags labeled as required.

p. SIGNS

a. Asbestos Caution Signs: Post an approximately 20 inch by 14 inch manufactured caution sign at each entrance to the Work Area displaying the following legend

with letter sizes and styles of a visibility required by 29 CFR 1926.1101. The asbestos waste bags shall have the same caution label.

LEGEND

DANGER  
ASBESTOS  
MAY CAUSE CANCER  
CAUSES DAMAGE TO LUNGS  
AUTHORIZED PERSONNEL ONLY  
WEAR RESPIRATORY PROTECTION AND  
PROTECTIVE CLOTHING IN THIS AREA

q. PART 3 - EXECUTION

r. EQUIPMENT

HEPA VACUUMING EQUIPMENT: Vacuuming equipment utilizing High Efficiency Particulate Air (HEPA) UL 586 filter system capable of collecting and retaining asbestos fibers.

s. AIR PURIFYING RESPIRATORS

1. Respirator Bodies: Provide half face, full face, or powered air purifying respirator (PAPR) type respirators.
2. Filter Cartridges: Provide, at a minimum, HEPA type filters labeled with NIOSH Certification for “Radionuclides, Radon Daughters, Dust, Fumes, Mists including Asbestos-Containing Dusts and Mists” and color coded in accordance with ANSI Z88.7 (2010). In addition, a chemical cartridge section may be added, if required for solvents, etc. In this case, provide combination cartridges labeled with the appropriate color code and NIOSH Certification.
3. Non-permitted respirators: Do not use single use, disposable or quarter face respirators.
4. Worker Requirements:
  1. Require that respiratory protection be used at all times that there is any possibility of disturbance of materials containing asbestos whether intentional or accidental.
  2. Require that a respirator be worn by anyone in a Work Area at all times, regardless of activity, during a period that starts with any operation which could cause airborne fibers until the area has been cleared for re-occupancy.
5. Regardless of Airborne Fibers: Require that the minimum level of respiratory protection used be half-face air-purifying respirators with high efficiency particulate air filters.

t. FIT TESTING

- A. Initial Fitting: Provide initial fitting of respiratory protection during a respiratory protection course of training. Fit types of respirator to be actually worn by each

individual. Allow an individual to use only those respirators for which training and fit testing have been provided.

- B. On an Annual Basis: Check the fit of each worker’s respirator by having irritant smoke blown onto the respirator from a smoke tube. The fit test frequency shall be according to the OSHA requirement.
- C. Upon Each Wearing: Require that each time an air-purifying respirator is put on it be checked for seal with a positive and negative pressure fit check in accordance with the manufacturer’s instructions or ANSI Z88.2 (2015).

u. TYPES OF RESPIRATORY PROTECTION NEEDED

A. Contractor Requirements: Provide Respiratory Protection as indicated in this Section. Higher levels of protection may be provided as desired by Contractor and Contractor’s employees. Where paragraph below does not apply, determine the proper level of protection by dividing the expected or actual airborne fiber count in the Work Area by the “protection factors” given below. The level of respiratory protection which supplies an airborne fiber level inside the respirator, at the breathing zone of the wearer, at or below 0.01 f/cc is the minimum level of protection allowed.

B. Protection Factors:

<b>RESPIRATOR TYPE</b>	<b>PROTECTION FACTOR</b>
Air purifying: Negative pressure respirator High efficiency filter Half or full facepiece	10
Powered Air Purifying Respirator (PAPR): Negative pressure respirator High efficiency filter Full facepiece	50
Type C supplied air: Positive pressure respirator Pressure demand Full facepiece	1,000
Type C supplied air: Positive pressure respirator, pressure demand Full facepiece equipped with an auxiliary positive pressure Self-Contained Breathing Apparatus (SCBA)	over 1,000

- C. Respirator Use: Use the following as a minimum unless air monitoring results indicate greater protection is necessary. Refer to Protection Factors table for choice of respirators.
  - A. Containment or barrier installation which does not disturb asbestos: Dual Cartridge, Half-face Air Purifying Respirators.

- B. Removing or cleaning items or barrier installation when such operation may disturb asbestos: Dual Cartridge, Half-face Air Purifying Respirators.
  - C. Asbestos Removal: Dual Cartridge, Half-face Air Purifying Respirators.
  - D. Gross Cleaning of Removal Area(s): Dual Cartridge, Half-face Air Purifying Respirators.
  - E. Final Wet-Cleaning of Area Until Final Air Tests Show Exposure In Work Areas to be Below 0.01 f/cc: Dual Cartridge, Half-face Air Purifying Respirators.
  - F. Loading and Unloading Drums On Truck (outside work area): Dual Cartridge, Half-face Air Purifying Respirators.
- D. Fibers: For purposes of this section fibers are defined as all fibers regardless of composition as counted in the OSHA Reference Method (ORM), NIOSH Method 7400 procedure, or asbestos fibers of any size as counted using either a scanning or transmission electron microscope.
- v. PROTECTIVE CLOTHING
- Furnish personnel exposed to asbestos fibers with disposable protective whole body clothing, head covering, gloves, and foot coverings. Furnish disposable plastic or rubber gloves to protect hands. Cloth gloves may be worn inside the plastic or rubber gloves for comfort, but shall not be used alone. Use tape to secure sleeves at the wrists and to secure foot coverings at the ankles.
- w. PERSONNEL DECONTAMINATION UNIT
- Provide a decontamination area adjacent to the work area, as applicable. Decontamination area will consist of a polyethylene sheet placed adjacent to the work area large enough for employees to remove disposable coveralls and shower prior to exiting the work area. Waste generated during decontamination will be disposed of as asbestos containing debris. At the conclusion of work the plastic sheet will be disposed of as asbestos containing waste. Position a HEPA vacuum at the decontamination unit which workers will use to clean off protective clothing prior to removal.
- x. CLEANING OF DECONTAMINATION UNITS
- Clean debris and residue from the Decontamination Area on a daily basis. Damp wipe or hose down all surfaces after each shift change.
- y. WORK PROCEDURE
- Conduct asbestos-related work in accordance with 29 CFR 1926.1101 and as specified herein. Use wet removal procedures. Personnel shall wear and use protective clothing and equipment as specified in the approved Work Plan. Eating, smoking, or drinking shall not be permitted in the asbestos control area or change room. Personnel of other trades not engaged in the removal of asbestos shall not be exposed at any time to airborne concentrations of asbestos greater than or equal to 0.01 fibers (longer than 5 micrometers) per cubic centimeter of air, unless the personnel protection provisions of this Section are complied with by the trade personnel.

z. ASBESTOS CONTROL AREA REQUIREMENTS

- A. Perimeter: Provide a marked perimeter around the work area during asbestos removal operations. No one will be permitted in the asbestos control area unless the person is provided with appropriate training and protective equipment. During the asbestos removal operation, should the asbestos abatement employees need to exit the controlled area, they shall vacuum and remove their disposable coveralls, place them in an approved impermeable disposal bag, and then exit the area.
- B. Personal Air Sampling During Work: Contractor shall conduct personal air monitoring samples on 25% of the work crew or a minimum of two employees whichever is greater during each work shift.
- C. Area Air Sampling During Work: An independent Industrial Hygienist (IH) retained by the General Contractor will conduct boundary samples upwind and downwind of the asbestos control area during each work shift. If the concentration of airborne asbestos fibers at the boundaries is greater than or equal to 0.01 fibers per cubic centimeter of air, or background quantity whichever is greater, Contractor shall stop work, and correct the condition(s) causing the increase. If adjacent areas are contaminated, the contaminated areas shall be cleaned and visually inspected by the IH and Contractor's Competent Person. IH shall certify that the area has been cleaned of asbestos contamination.

aa. ASBESTOS HANDLING PROCEDURES

- 1. General Procedure: If removing asbestos from components or removing components with asbestos adhered to it, wet asbestos material with a fine spray of amended water. Remove material and immediately place in approved impermeable bags that have been wetted. Collect asbestos waste, scrap, debris, bags, containers, equipment, and asbestos-contaminated clothing and place in sealed impermeable bags constructed of 6-mil plastic sheet.
- 2. Container Labeling: Provide asbestos caution labels on sealed impermeable bags and asbestos waste containers. When applicable, use a lined chute, hoist, lift or other State-approved method to move double-bagged asbestos containing waste material from roof, or upper floors, to asbestos waste transport container. If chute is used, it must be affixed with a negative pressure unit to minimize airborne fiber concentrations.

bb. AIR MONITORING

- A. Work Area Airborne Fiber Levels: IH retained by Contractor will monitor airborne fiber levels in the Work Area, as applicable. The purpose of this air monitoring will be to detect potential airborne asbestos concentrations inside and outside of the control area.
- B. Outside the Work area (Barrier) Fiber Levels: IH will assess airborne fiber levels outside the work area to determine if leakage is occurring into non-work areas.
  - 1. IH will conduct air monitoring throughout the project.
  - 2. Contractor is responsible for his/her worker protection and personal air monitoring and legally-required documentations.

cc. STOP ACTION LEVELS

- A. Inside Work Area: Maintain airborne levels in the work area of less than the Stop Action Level given below for the type of respiratory protection in use. If the fiber counts levels rise above this figure for any sample taken, revise work procedures to lower fiber counts. If fiber count levels for any work shift or 8 hour period exceeds the Stop Action Level, stop work except corrective action and leave air circulation system in operation. After correcting cause(s) of high fiber levels, do not recommence work for 24 hours unless otherwise authorized by the IH.

ASBESTOS		
STOP ACTION LEVEL (f/cc)	RESPIRATOR REQUIRED	PROTECTION FACTOR
1	Half face APR	10
5	Full face APR	50
10	PAPR or Type C, Continuous flow	100
100	Type C, Pressure demand	1,000

- B. Outside Work Area: If any air sample taken outside of the Work Area exceeds the baseline established prior to start of work, immediately and automatically stop work except corrective action. Contractor shall determine the source of the high reading and take appropriate corrective actions.

If the high reading was the result of a failure of Work Area isolation measures, initiate the following actions:

- A. Decontaminate the affected area(s).
- B. Require that respiratory protection be worn in affected the area until the area is cleared for other trade or reoccupancy.
- C. If the high reading was the result of other causes, initiate corrective action as determined by the Competent Person and the IH.
- C. Fibers Counted: Phase Contrast Microscopy (PCM) method will be used to analyze the asbestos air samples. Transmission Electron Microscopy (TEM) analysis will be used to resolve any disputes regarding fiber types when a project has been stopped due to excessive airborne fiber counts. The DOW representative will collect the TEM sample(s), and the Contractor may collect their own TEM sample(s); all costs of TEM sample collection and analysis shall solely be borne by the Contractor.

dd. ANALYTICAL METHODS



The following methods will be used in analyzing filters used to collect air samples. The filters used shall be in accordance with the referenced methods.

- A. PCM Analysis: Samples collected for PCM analysis shall be analyzed by NIOSH 7400 method.
- B. TEM Analysis: Samples collected for TEM analysis shall be analyzed by NIOSH 7402 method.

ee. SAMPLE VOLUMES

Number and volume of air samples taken by the IH will be in accordance with the following schedule. Sample volumes given may vary depending upon the analytical method used and Contractor method of removal.

ff. BASELINE

IH will secure the following air samples to establish a baseline before start of asbestos removal work:

LOCATION SAMPLED	NUMBER OF SAMPLES MINIMUM	MINIMUM VOLUME (LITERS)	RATE (LPM)
Each Work Area	2 for up to 5000 sq.ft.; one additional per each additional 5000 sq.ft.	1,199	1-12
Outside the Work Area	1	1,199	1-12

gg. DAILY

1. Sample Collection: From start of work and as applicable, IH will take the following samples during removal of asbestos:

SAMPLE TYPE SAMPLE LOCATION	MINIMUM NUMBER OF SAMPLES	MINIMUM SAMPLE VOLUME (LITERS)	SAMPLE FLOW RATE (LPM)
Work Area – Each Work Area	2 per shift	480	1-5
Barrier – Area outside of containment unit (determined by the IH)	2 per shift, unless sample area is dusty; then increase number as necessary	480	1-12
Barrier – Clean Room of Decon Unit	1 per shift, unless sample area is dusty; then increase number as necessary	480	1-12

2. Additional Sampling: Additional samples may be taken at the IH's and DOW's discretion. If airborne fiber counts exceed allowed limits, additional samples shall be

taken as necessary to monitor fiber levels. Personal monitoring performed by the IH shall not remove the Contractor's responsibility to monitor his/her workers' health & safety and required documentations.

hh. AIR SAMPLING MEDIA

Sample Cassettes: Samples will be collected on 25 mm. cassettes with 50 mm. extension cowl as follows:

PCM: 0.8 micrometer mixed cellulose ester.

ii. LABORATORY TESTING

1. Area Air Sampling Results: Services of a testing laboratory will be employed by the IH. IH will obtain samples daily. Asbestos air sample results will be obtained within 24 hours of sample submittal. Contractor and DOW will have access to air monitoring tests and results.
2. Personal Air Sampling Results: Contractor is responsible for laboratory analysis for the personal air monitoring. Results shall be made available within 24 hours of sample submittal.

jj. CLEANUP AND DISPOSAL

- a. Cleanup: Maintain surfaces of the asbestos control area free of accumulations of asbestos fibers. Restrict the spread of dust and debris; keep waste from being distributed over the general area. Do not dry sweep or blow down the space with compressed air. When asbestos removal, disposal, and cleanup are complete, The IH will certify, in writing, that the concentration of airborne asbestos in the control area and barrier samples are less than 0.01 fibers (longer than 5 micrometers) per cubic centimeter of air, and that there are no visible accumulations of dust, personal protective equipment (PPE) were adequate, work procedures, asbestos removal, boundary samples disposal procedures, containment and clearances samples were in accordance with 29 CFR 1926.1101 and contract specifications.
- b. Visual Inspection: Competent Person and the IH will visually inspect the affected surfaces for residual asbestos material and accumulated dust before and after the removal of the asbestos control area; Contractor shall reclean areas showing dust or residual asbestos materials. If recleaning is required, monitor the asbestos airborne concentration during and after recleaning.
- c. Disposal of Asbestos: Dispose of waste asbestos material at a State and EPA approved landfill. Procedure for hauling and disposal shall comply with 40 CFR 61, Subpart M, and State and local standards. Sealed and labeled impermeable bags may be dumped from transport vehicles into the burial site unless bags have been broken or damaged. Damaged bags shall be repaired or rebagged, or transported in suitable containers or drums. Uncontaminated drums may be recycled. Contractor's and landfill's workers loading and unloading asbestos waste bags shall wear appropriate respirators and personal protective equipment.
- d. Double Tape Wrapped: Asbestos materials shall be wrapped in 6-mil minimum thickness polyethylene sheets and taped with minimum 2-inch wide duct tape. Asbestos materials

shall be double-wrapped and taped before disposal at the approved landfill. Each bundle of wrapping shall not exceed 50 pounds in weight. Damaged polyethylene sheeting will not be accepted for disposal at the landfill.

- e. Waste Shipment Records: Prior to delivery of asbestos waste materials, Contractor shall complete the EPA’s Waste Shipment Records requirements on manifesting asbestos waste removal, transportation, and final disposal. Payment for this Section will not be made until a completed manifest from the disposal facility is returned, and a copy furnished to DOW. Copy and instructions for Waste Shipment Record are attached at the end of this Section.

kk. MEASUREMENT AND PAYMENT

Work involving removal and disposal of asbestos and renovation debris shall not be measured or paid for separately but shall be considered incidental to the lump sum price bid for the item of which it is a part in the Offer Schedule.

ENTRY LOG

(Sample Visitor Log)

DATE: \_\_\_\_\_

PROJECT: \_\_\_\_\_

SUPERVISOR: \_\_\_\_\_

ALL PERSONNEL MUST SIGN-IN AND SIGN-OUT EVERY TIME THEY ENTER/EXIT THE WORK AREA. PLEASE PRINT CLEARLY. ATTACH EMPLOYEE RELEASE FORM FOR ALL VISITORS.

Name	Employer Name, address*, phone*	Time in	Time out	Purpose of visit	Type of PPE issued**

\*Not required of Contractor’s employees.

\*\*Type of PPE (Personal Protective Equipment) issued to include list of protective clothing worn and type of respirator used (Type “C,” half-face dual cartridge, etc.)

Note:

EMPLOYEE RELEASE FORM

(Sample)

Employee Name:

Employee Address:

Employee Telephone No.:

Name of Training center, Certificate Number and expiration Date:

Classification of work:

Have you had in the past or present, any respiratory problems?

Yes

No

Have you worked in the past with asbestos or fiberglass type materials?

Yes

No

The project you will be working on involves the use of asbestos and the removal of the asbestos from the building. Asbestos is considered a health hazard.

The company is supplying all necessary safety clothing and working conditions required and necessary for your protection from asbestos hazard.

You shall be instructed at the commencement of the job on the required use of safety equipment, clothing, working conditions, and procedures. These must be rigidly adhered to. Smoking is not permitted in the work area. Disregarding of safety instructions shall result in instant dismissal.

I acknowledge that safety instructions have been given to me by the company at my work commencement and I am thoroughly conversant with them and I have answered the above questions truthfully.

Signed (Employee)

Date

Print name

CERTIFICATE OF WORKER'S ACKNOWLEDGEMENT

PROJECT NAME: \_\_\_\_\_

DATE: \_\_\_\_\_

PROJECT ADDRESS: \_\_\_\_\_  
\_\_\_\_\_  
\_\_\_\_\_

CONTRACTOR: \_\_\_\_\_

WORKING WITH ASBESTOS CAN BE DANGEROUS. INHALING ASBESTOS FIBERS HAS BEEN LINKED WITH VARIOUS TYPES OF CANCER. IF YOU SMOKE AND INHALE ASBESTOS FIBERS THE CHANCE THAT YOU WILL DEVELOP LUNG CANCER IS GREATER THAN THAT OF THE NON-SMOKING PUBLIC.

Your employee contract with the Owner for the above project requires that: You be supplied with the proper respirator and be trained in its use. You be trained in safe work practices and in the use of the equipment found on the job. You receive a medical examination. These things are to have been done at no cost to you.

RESPIRATORY PROTECTION: You must have been trained in the proper use of respirators, and informed of the type respirator to be used on the above referenced project. You must be given a copy of the written respiratory protection manual issued by your employer. You must be equipped with the respirator to be used on the above project at no cost.

TRAINING COURSE: You must be trained in the dangers inherent in handling asbestos and breathing asbestos dust and proper work procedures and personal and area protective measures. The topics covered in the course must have included the following:

- Physical characteristics of asbestos
- Health hazards associated with asbestos
- Respiratory protection
- Use of protective equipment
- Pressure Differential Systems
- Working practices include hands on or on-job training
- Personal decontamination procedures
- Air monitoring, personal and area

MEDICAL EXAMINATION: You must have had a medical examination within the past 12 months at no cost to you. This examination must have included: health history, pulmonary function tests and may have included an evaluation of a chest X-ray.

By signing this document you are acknowledging only that the Owner of the building you are about to work in has advised you of your right to training and protection relative to your employer, the Contractor.

Signature \_\_\_\_\_

Social Security No. \_\_\_\_\_

Print Name \_\_\_\_\_

Witness \_\_\_\_\_

**ASBESTOS DISPOSAL FORM (Sample)**

<b>GENERATOR</b>	1. WORK SITE NAME & MAILING ADDRESS	OWNER'S NAME	OWNER'S TELEPHONE NO.
	2. OPERATOR'S NAME & ADDRESS		OPERATOR'S TELEPHONE NO.
	3. WASTE DISPOSAL SITE (WDS) NAME, MAILING ADDRESS, AND PHYSICAL SITE LOCATION		WDS TELEPHONE NO.
	4. NAME AND ADDRESS OF RESPONSIBLE AGENCY		
	5. DESCRIPTION OF MATERIALS	6. CONTAINERS NO.      TYPE	7. TOTAL QUANTITY M <sup>3</sup> (YD <sup>3</sup> )
	8. SPECIAL HANDLING INSTRUCTIONS AND ADDITIONAL INFORMATION		
9. OPERATOR CERTIFICATION: I HEREBY...			
	PRINTED/TYPED NAME & TITLE	SIGNATURE	DATE (MO/DY/YR)
<b>TRANSPORTER</b>	10. TRANSPORTER 1 (ACKNOWLEDGEMENT OF RECEIPT OF MATERIALS)		
	PRINTED/TYPED NAME & TITLE	SIGNATURE	DATE (MO/DY/YR)
	11. TRANSPORTER 2 (ACKNOWLEDGEMENT OF RECEIPT OF MATERIALS)		
	PRINTED/TYPED NAME & TITLE	SIGNATURE	DATE (MO/DY/YR)
<b>DISPOSAL SITE</b>	12. DISCREPANCY INDICATION SPACE		
	13. WASTE DISPOSAL SITE OWNER OR OPERATOR: CERTIFICATION OF RECEIPT OF ASBESTOS MATERIALS COVERED BY THIS MANIFEST EXCEPT AS NOTED IN ITEMS 1, 2, AND 3.		
	PRINTED/TYPED NAME & TITLE	SIGNATURE	DATE (MO/DY/YR)

ASBESTOS NOTIFICATION OF DEMOLITION & RENOVATION

(Ref. HAR Chapter 11-501)

SEND TO: STATE DEPARTMENT OF HEALTH  
 INDOOR AND RADIOLOGICAL HEALTH BRANCH  
 STATE OF HAWAII ASBESTOS PROGRAM  
 99-945 HALAWA VALLEY STREET  
 AIEA, HAWAII 96701  
 Phone (808) 586-5800 Fax 586-5811

<b>I. Type of notification:</b> O=original R=revised C=cancelled		
<b>II. Type of operation:</b> D=demolition R=renovation OD=Ordered Demolition ER=Emergency Renovation		
<b>III. Facility information</b>		
Owner name:		
Address:		
City:	State:	Zip code:
Contact person:		Telephone#:
Removal contractor:		License#:
Address:		
City:	State:	Zip code:
Contact person:		Telephone#:
Other Operator		
Address:		
City:	State:	Zip code:
Contact person:		Telephone#:
<b>IV. Is asbestos present (Y/N):</b>		
Inspector's name:	Certification#:	State of certification:
<b>V. Facility description (Include building number, floor and room number)</b>		
Building name:		
Address:		
City:	State:	Zip code:
Site location:		
Building size:	Floors:	Age:
<b>VI. Procedure used to detect the presence of asbestos</b>		
Laboratory name:		Analytical method
<b>VII. Specify the nature of the asbestos material (TSI, surfacing, VAT, miscellaneous):</b>		
Amount of asbestos, including:	RACM to be Removed	Nonfriable ACM <u>not</u> to be removed



a. RACM to be removed		Category I	Category II
b. CATI left in place, and			
c. CATII left in place			
Pipes (linear ft.)			
Surfacing (square ft.)			
Facility components (Cu. ft.)			

<b>VIII. Scheduled asbestos abatement dates</b>		
Start (mm/dd/yy):	Finish (mm/dd/yy)	
Circle workdays and time:	Weekdays: daytime:      nighttime:	Weekends: daytime:      nighttime:
<b>IX. Scheduled renovation/demolition dates</b>		
Start (mm/dd/yy):	Finish (mm/dd/yy)	
Circle workdays and time:	Weekdays: daytime:      nighttime:	Weekends: daytime:      nighttime:
<b>X. Description of the planned renovation/demolition work and methods to be used:</b>		
<b>XI. Description of the work practices and engineering controls to be used to prevent emissions of asbestos from the work-site:</b>		
Project designer name:	Certification#:	State:
<b>XII. Waste transporter #1</b>		
Name :		
Address :		
City:	State:	Zip code:
Contact person:	Telephone#:	
<b>Waste transporter #2</b>		
Name :		
Address :		
City:	State:	Zip code:
Contact person:	Telephone#:	
<b>XIII. Waste disposal site:</b>		
Facility Name:	Telephone#:	
Address :		
City:	State:	Zipcode:
<b>XIV. For demolition ordered by a government agency, please identify:</b>		
Name:	Title:	
Authority (Agency):		
Date of order (mm/dd/yy):	Date ordered to begin (mm/dd/yy):	
<b>XV. For emergency renovation:</b>		

Date and time of emergency Date (mm/dd/yy): _____ Time: _____ (a.m./p.m.)	
Description of sudden, unexpected events and the damage caused:	
Explanation of how the event caused an unsafe condition or would cause damage or an unreasonable financial burden:	
Person contacted for the approval at the Noise, Radiation & Indoor Air Quality Branch: Name: _____ Date (mm/dd/yy): _____ Time: _____ (a.m./p.m.)	
<b>XVI. Description of procedures to be followed in the event that unexpected asbestos is found or previously nonfriable asbestos material becomes crumbled, pulverized or reduced to powder.</b>	

<b>XVII. I certify that an individual trained in the provisions of Hawaii administrative rules chapter 11-501, and certified as a contractor/supervisor, will be on-site during the entire renovation and/or demolition and evidence that the required training has been accomplished for this and all workers will be available at the work-site.</b>	
_____	_____
Signature of owner/operator	Date (mm/dd/yy):

<b>XVIII. I certify that the information on this notification is correct.</b>	
_____	_____
Signature of owner/operator	Date (mm/dd/yy):

**XIX. Additional Comments:**


END OF SECTION

## SECTION SP-4 – LEAD HAZARD CONTROL

### 1. GENERAL PROJECT DESCRIPTION

Contractor shall review the existing lead survey data and verify the locations and quantities of lead paints to be disturbed.

1. For the purpose of this Section, all paints with measurable levels of lead are considered Lead-Containing Paint, which shall be removed or disturbed in accordance with applicable rules and regulations.
2. Total Lead-Based Paint abatement is anticipated for the interior of the tank, and loose and flaky paint removal is anticipated for the exterior of the tank. Any paint removal or disturbance work shall be conducted in a manner preventing exposures to the site workers, facility users, the public, and the environment.

### 3. CONFIRMED LCP

Lead-containing paints were confirmed in the project areas as follows:

#### Tank Interior:

Beige coating on concrete floor, 40,000 mg/kg – 41,000 mg/kg.

#### Tank Exterior:

Light blue paint on concrete roofing system, 710 mg/kg – 1,200 mg/kg.

Dark green paint on metal hatch, 41,000 mg/kg – 55,000 mg/kg.

Light green paint on metal handrails and ladder, 1,200 mg/kg – 1,400 mg/kg.

### 4. ENGINEERED CONTROLS

Contractor must implement appropriate engineering controls and safety measures to prevent site workers, facility users, other trades, public, and environmental exposures to lead hazards.

### 5. PERSONNEL NOTIFICATION

Contractor shall inform their employees, subcontractors, and other persons conducting work for this project, that interior and exterior surfaces of the existing tank and components associated with this project have lead-containing paints. Contractor, his/her employees, and subcontractors shall initiate and maintain applicable programs necessary to execute the work in accordance with the contract documents, Federal, State, and local rules and regulations.

### 6. REGULATORY COMPLIANCE

Contractor shall be responsible for ensuring that work generating lead containing debris conforms to the following applicable Federal, State and local rules and regulations.

#### 1. Federal Regulations:

1. Occupational Safety and Health Administration (OSHA)

2. Environmental Protection Agency (EPA)
3. Toxic Substance Control Act (TSCA 40 CFR Part 745 Lead) Requirements for Lead-Based Paint Activities in Target Housing and Child Occupied Facilities
4. National Emission Standards of Hazardous Air Pollutants (NESHAP)
5. EPA Resource Conservation and Recovery Act (RCRA) of 1976, amended in 1980 and 1984.

2. State Regulations:

1. Hawaii Occupational Safety and Health (HIOSH) rules
2. Hawaii Administrative Rule (HAR) Title 11, Chapter 41 – LEAD-BASED PAINT ACTIVITIES

3. SAFETY

Contractor shall be responsible for initiating and maintaining safety precautions and programs necessary to keep the work place safe for his/her employees and subcontractors.

4. WASTE CLASSIFICATION

Contractor shall characterize waste generated prior to transport off-site, by collecting representative sample(s) of the waste per landfill or recipient's requirements. The landfill acceptance and appointment are required prior to transporting waste to the landfill.

5. ADDITIONAL COSTS

Costs incurred due to Contractor's inability to control hazards shall be borne solely by Contractor, including but not limited to, medical, legal, public and regulatory relations, investigation, clean-up, monitoring, and reporting.

6. COORDINATION WITH OTHER SECTION

Contractor shall refer to SECTION SP6 - TESTING/AIR MONITORING for requirements of work when disturbing hazardous materials.

7. LEAD-BASED PAINT FIELD TESTING

Contractor may conduct a paint testing for lead, utilizing X-Ray Fluorescence (XRF) analysis or Atomic Absorption Spectrophotometry Analysis (AAS).

1. Testing: Testing shall be conducted by an industrial hygienist, at Contractor's expense.
2. Test Results: Test results shall be presented to the DOW representative for evaluation. Contractor's work practices, air monitoring and clearance requirements may be modified in accordance with paint test results. XRF results shall not be used in determining PPE levels.

8. SUBMITTALS

B. Lead Hazard Control Plan: Contractor shall submit a Lead Hazard Control Plan 20 calendar days prior to lead disturbance work, including but not limited to:

1. A clear scope of work
2. Description of methods to control lead hazards and dust
3. A sketch of lead hazard control area and staging area for waste containers, equipment, and supplies
4. Site Supervisor and/or Competent Person's name, contact number, and certifications
5. Written Hazard Communication (HAZCOM) program, including worker training records
6. Written Respiratory Protection Program
7. Medical surveillance records
8. Written Emergency Procedures Plan
9. Product specifications and safety data sheets (SDS)
10. Hazardous waste disposal plan

C. Closing Documents: Within 10 days of waste disposal, Contractor shall submit the following:

1. A copy of the Hazardous Waste Disposal Log and the completed waste manifest
2. Field records including daily field notes and photographs
3. Sampling and analysis results

11. PART 2 - PRODUCTS

12. MATERIALS

C. Polyethylene Bags and Sheets: 6 mil minimum thickness in sizes required to accomplish the work.

D. Other Materials: Provide materials, such as, but not limited to, rags, lumber, plywood, fasteners, duct tape, and sealant which may be required to properly prepare and complete the work.

13. TOOLS AND EQUIPMENT

HEPA Vacuuming Equipment: Vacuuming equipment utilizing High Efficiency Particulate Air (HEPA) filters.

14. PART 3 - EXECUTION

15. PREPARATION PRIOR TO DISTURBANCE OF LEAD-CONTAINING PAINT

1. Existing Conditions: Document existing paint chips or debris prior to work (interior and exterior), as applicable.
  - A. PRE-CLEANING: If there are any paint chips or debris in the project area, Contractor shall pre-clean horizontal surfaces within the work area prior to disturbing existing LCP.
  - B. PRE-CLEANING WASTE: Contractor shall treat paint chips or debris collected during pre-cleaning and during project related activities as lead-containing waste.
2. Lead Dust Control: Minimize lead-containing dust during work performance using wet methods and equipment with HEPA collection devices. If visual inspection, air monitoring, or clearance by Competent Person, IH, or DOW indicates that control measures are inadequate, Contractor shall stop work, clean up the affected area, and implement enhanced engineering controls at no additional cost to DOW.
3. Lead Control Area: Isolate and protect the portions of the area not within the scope of work using 6-mil polyethylene sheeting, or equivalent.
4. Pre-work visual inspection: Inspect the immediate project and adjacent areas for the presence of paint chips or debris and document the physical conditions with photographs and narratives. This documentation will serve as baseline conditions to which final visual clearance will be compared.
5. Exterior Control Areas: Demarcate the exterior lead control area using lead warning tape.
  1. Lead Warning Tape: Lead warning tape shall be at least 20 feet away from the closest painted surface being disturbed. Lead warning tape may be placed closer only if existing structural conditions prevent a 20-foot space between the lead warning tape and the working surface.
  2. Polyethylene Sheeting: Place 6-mil polyethylene drop sheets around exterior surfaces.
    1. Secure drop sheets so that wind, rain, or other forces will not dislodge the sheets.
    2. Drop sheets shall extend horizontally, where applicable, at a distance sufficient to capture debris containing paint and substrates.
    3. Drop sheets shall be periodically cleaned and kept free of debris. Any water captured by the drop sheet shall be contained and treated as lead-contaminated.

4. CONFORMANCE

1. WORK EXECUTION:

Work shall be executed in accordance with the following:

1. OSHA: Contractor shall ensure that work executed in this project is in accordance with the requirements of 29 CFR 1910.1025 and 29 CFR 1926.62.
  1. Cost associated with the execution of work in accordance with these OSHA rules shall be the Contractor's responsibility.
  2. Negative exposure assessment, air monitoring and testing cost shall be borne by the Contractor.

2. HOUSEKEEPING: Contractor shall implement good housekeeping to control the airborne lead dust when disturbing painted surfaces.
  - 1) Engineering controls shall be implemented to minimize the spread of wind-blown dust.
  - 2) Minimum 6 mil polyethylene shall be placed on the floors and walls, minimum 10-feet on each side of where disturbance is anticipated.
  - 3) At the end of each work day, Contractor shall remove visible debris and dust, HEPA vacuum, and wet-wipe below and around existing horizontal and vertical surfaces where disturbance of hazardous material was conducted.
  
3. EPA RESOURCE CONSERVATION AND RECOVERY ACT (RCRA) OF 1976, AMENDED IN 1980 AND 1984:
  - b. The project site may fall into the category of Conditionally Exempt Small Quantity Generator (CESQG) if the facility generates less than 100 kilograms/month or 220 pounds/month of hazardous waste. Contractor shall be responsible for the completion of the Hazardous Waste Disposal Log provided in Appendix A of this Section.
  - c. Under the requirements for a CESQG, the generator:
    - a. Must identify painted surfaces with LCP or assumed LCP, and the hazardous waste or acute hazardous waste generated at each site.
    - b. Not store more than 1,000 kg or 2,200 pounds of hazardous waste, or assumed hazardous waste, at each site at any time.
    - c. Can dispose of the waste in a municipal solid waste (MSW) landfill provided that Toxicity Characteristic Leaching Procedure (TCLP) results meet the landfill acceptance criteria, 5.0 milligrams per liter (mg/L) lead and 1.0 mg/L cadmium.
    - d. Must dispose of the waste material at an EPA approved landfill off-island that accepts such waste if the TCLP results indicate that the material is hazardous waste (at or above 5.0 mg/L lead or 1.0 mg/L cadmium).
  - d. Treatment of assumed to be Lead-Containing Debris:
    - a. Debris resulting from Contractor's work, such as cutting, scrapping, drilling, coring, chipping, or sanding, of known or assumed LCP surfaces, shall be segregated from the rest of the construction debris.
    - b. Hazardous waste and assumed to be hazardous waste amounts exceeding the CESQG limit shall follow RCRA regulations for Small Quantity Generator or Large Quantity Generator.
  - e. Disposal of Lead-containing Paint Debris:
    1. LCP or assumed LCP debris generated by the Contractor must conform to the requirements of this Section.
    2. Paint debris with TCLP lead concentration below 5.0 mg/L and TCLP cadmium below 1.0 mg/L may be disposed of at a municipal solid waste landfill that accepts such waste.

3. Disposal of renovation debris on private land is prohibited, unless it is permitted by the State and the EPA.
4. Paint debris with TCLP lead and cadmium concentrations at or above 5.0 mg/L and 1.0 mg/L, respectively, must be disposed of as hazardous waste at an EPA-approved landfill off-island that accepts such waste.
5. Accumulation and mixing of hazardous waste of one generator (facility) with that of another generator is prohibited.
6. Disposal shall be in accordance with the permit requirements of the Municipal Solid Waste Landfill.
7. Contractor shall be responsible for costs related to the disposal of assumed LCP debris and hazardous paint chip waste.

#### 4. ACTIVITIES DISTURBING LEAD-CONTAINING PAINT

- A. **Work Performance:** Conduct LCP removal as required for this project, and minimize lead-containing dust using wet methods and HEPA equipment. If visual inspection indicates control measures are inadequate, the Competent Person must stop work, notify the DOW, conduct clean-up, and implement enhanced engineering controls immediately at no additional cost to DOW.
- B. **Lead Debris Cleanup:** Do not execute dry removal or dry sweeping. Waste or paint debris generated during removal shall be promptly staged or packaged, and shall not accumulate uncontrolled at any time. Lead-containing waste shall be properly marked and stored in secure containers appropriate for storing lead-containing waste.
- C. **Lead Waste Storage:** Contractor shall not allow lead-containing waste to be stored outside of the lead control area, in a high traffic unsecured area, or where the waste could interact with rain or wind and create a secondary hazard or contamination.

#### 5. LEAD CONCENTRATIONS IN THE WORK AREA

1. **Maximum Exposure Limit:** Maximum permissible exposure to airborne concentrations of lead within the project area shall be 30 micrograms per cubic meter ( $\mu\text{g}/\text{m}^3$ ) air. Stop work whenever this limit exceeded, and Competent Person shall remedy the condition prior to commencing work.
2. **Respirator Training:** Instruct and train each worker in proper respiratory use.
  1. **Requirement:** Require that each worker always wear a respirator, properly fitted on the face, in the work area from the start of any operations which may cause airborne lead dust until the work area passes the required clearance.
  2. **Applicability:** Use respiratory protection appropriate for the lead dust levels encountered in the work place or as required for other toxic or oxygen-deficient situations encountered.
3. **Air Purifying Respirators:** Provide half-face or full-face type respirators.
  - A. **Filter Cartridges:** Provide, at a minimum, HEPA type filters labeled with the National Institute for Occupational Safety and Health (NIOSH) Certification for "Radionuclides, Radon Daughters, Dust, Fumes, Mists including Asbestos-Containing Dusts and Mists" and color coded in accordance with ANSI Z228.2. In addition, a chemical cartridge section may be added.



- B. Non-Permitted Respirators: Do not use single use, disposable or quarter-face respirators.
  - C. Respirator Use: Require that respiratory protection be used whenever there is any possibility of LCP disturbance, intentional or accidental. Require that a respirator be worn by anyone in a lead control area at all times when LCP is disturbed.
  - D. Regardless of Lead-Containing Dust Levels: Require that the minimum level of respiratory protection used be half-face air-purifying respirators with HEPA filters.
4. Fit Testing:
- 1. Initial Fitting: Provide initial fitting of respirators during respiratory protection training. Fit types of respirator to be actually worn by each individual. Allow an individual to use only those respirators for which training and fit testing have been provided.
  - 2. On an Annual Basis: Check the fit of each worker's respirator using irritant smoke. Valid fit test certificates shall be included in the Lead Hazard Control Plan which shall be maintained onsite.
  - 3. Upon Each Wearing: Require that each time an air purifying respirator is donned, it will be checked for proper fitting with a positive and negative pressure seal checks in accordance with the manufacturer's instructions or ANSI Z88.2 (2015).
5. Type of Respiratory Protection Required:
- 1. Protection: factors" given below.
  - 2. Considerations: Consider the following unless air monitoring results indicate greater protection is necessary. Refer to the Protection Factors table for choice of respirators.
    - 1. Loose equipment cleaning prior to removal in uncontaminated area: Half-face dual cartridge-type respirator.
    - 2. Plastic installation which does not disturb LCP: Half-face dual cartridge-type respirator.
    - 3. Removing or cleaning items or plastic installation when such operation may disturb lead paints or lead dust: Half-face dual cartridge-type respirator.
  - 6. Area Inspections: Contractor's Competent Person and IH shall frequently inspect the controlled areas and adjacent areas. Contractor activities shall not adversely impact the indoors or outdoors air and horizontal surfaces and ground of the project site.

6. STOP ACTION LEVELS

- 1. Inside Work Area: Maintain airborne levels in the work area of less than the Stop Action Level given below for the type of respiratory protection in use.
- 2. Dust Levels: If the lead dust levels rise above this figure for any sample taken, enhance work procedures and engineering controls to lower ambient dust levels.
- 3. Stop Action Level Requirements: If lead dust levels for any work shift or 8-hour period exceeds the Stop Action Level, stop work except corrective action, and the Competent Person shall notify the DOW representative. After correcting the cause of lead dust levels, recommence work only after approval by the Competent Person. Competent Person shall document all decisions and follow-up actions and include them in the closeout report.

7. PROTECTIVE CLOTHING

Furnish personnel exposed to lead-containing dust with disposable protective whole body clothing, head covering, gloves, and foot coverings. Furnish disposable plastic or rubber gloves to protect hands from lead.

PROTECTION FACTORS

RESPIRATOR TYPE	PROTECTION FACTOR
Air purifying: Negative pressure respirator HEPA filter Half facepiece	Up to 500 µg/m <sup>3</sup>
Powered-air purifying respirator (PAPR): Negative pressure respirator HEPA filter Full facepiece	Up to 2,500 µg/m <sup>3</sup>
PAPR Positive pressure respirator HEPA filter Half or full facepiece or Type C supplied air: Positive pressure respirator Continuous-flow half or full facepiece	Up to 5,000 µg/m <sup>3</sup>

8. WARNING SIGNS AND LABELS

- 15.01 Signs At Control Areas: Provide warning signs at approaches to the lead control areas. Locate signs at such a distance that personnel may read the sign and take necessary precautions before entering the area/
- 15.02 Container Labeling: Provide and affix labels to impermeable bags, lead waste drums, and other containers containing lead materials, scrap, waste, or debris.
- 15.03 Sign Requirements: Signs and labels shall comply with the requirements of 29 CFR 1910.1025.

9. TOOLS

Filters on vacuums and exhaust equipment shall be absolute HEPA filters and UL 586 labeled.

10. AIR MONITORING

- A. Employee Monitoring: Contractor’s Competent Person shall monitor employees’ exposure to lead in accordance with OSHA requirements. Contractor shall collect air samples from employees’ breathing zones during each shift, for the duration of the LCP-disturbing work. Contractor shall collect samples from at least 25% of workers conducting LCP-disturbing tasks, and not less than two workers.
- B. Environmental Sampling During Paint Removal Work: Retain an independent Industrial Hygienist (IH). The independent IH will conduct area air sampling daily. Sufficient area

monitoring shall be conducted to verify unprotected personnel are not exposed at or above the maximum exposure limit, 30 micrograms per cubic meter air.

1. If action level is reached, stop work and correct conditions causing the elevated airborne lead dust levels. Resume only after approval of the IH.
2. Cost of retesting due to Contractor's inability to control lead dust shall be borne by Contractor.
3. For outdoor operations, IH shall determine the location and number of samples to be taken.

Work area and Adjacent:

LEAD

STOP ACTION LEVEL ( $\mu\text{g}/\text{m}^3$ )	RESPIRATOR REQUIRED	PROTECTION FACTOR
50	Half-face APR	10
5,000	PAPR or Type C, Continuous flow	100
50,000	Type C, Pressure demand	1,000

- C. Additional Actions: If the high lead air concentrations were the result of Contractor's failure of work area isolation measures, initiate the following actions:
1. Decontaminate the affected area(s).
  2. Require that respiratory protection be worn in affected area until the area is cleared.
- D. Corrective Action: If the high reading was the result of other causes, initiate corrective action as determined by the IH.
- E. Effect on Contract Sum: Complete corrective work with no change in the Contract Sum if lead-containing dust levels exceeding  $30 \mu\text{g}/\text{m}^3$  were caused by Contractor's activities. Costs involving delay, re-cleaning, additional lead air monitoring and quality control, investigation, and reporting shall be borne by Contractor.

3. ANALYTICAL METHODS

1. NIOSH 708 method shall be used in analyzing air samples. Filters used shall be in accordance with the referenced method
2. NIOSH 9100 method shall be used in analyzing lead wipe samples.

3. AIR SAMPLE MEDIA

Lead Sample Cassettes: Air samples will be collected on 37 millimeter (mm) cassettes with 50 mm extension cowl with 0.8 micrometer cellulose ester membrane.

4. LABORATORY TESTING

Testing Laboratory: Services of a testing laboratory shall be employed by the IH. Lead air sample results will be made available within 24 hours upon receipt of laboratory analytical results. DOW and Contractor will have access to air monitoring tests and clearance results.

5. CLEAN UP

1. Lead-Paint Chips and Dust: Maintain surfaces of the lead control area free of accumulations of paint chips and dust. Prevent the spread of dust and debris; keep waste from being distributed over the general project area.
  1. Dry Sweeping: Do not dry sweep the area.
  2. Completion of Lead Removal Work: When the paint removal, or renovation is completed:
    1. Clean visible lead paint contamination by vacuuming with a HEPA vacuum followed by wet mopping and wiping.
    2. Contractor shall certify that the work was completed in accordance with OSHA 29 CFR 1910.1025, HUD 24 CFR 35, and EPA 40 CFR 745, and that there are no visible accumulations of lead-containing paint and dust in the project areas.
    3. Competent Person and IH shall visually inspect the affected surfaces for residual lead paint chips and accumulated lead-containing dust after the work is completed.
    4. Contractor shall re-clean areas showing lead-containing dust or residual lead paint chips to the satisfaction of DOW.
5. Adjacent Areas: Contractor is responsible for the restoration and cleaning of any areas outside the work area impacted by or contaminated by lead-containing dust or debris generated by the Contractor's work, such as removal, handling, or storage of lead-containing waste. Contractor shall perform remedial cleaning and restoration of these areas, if any, at no additional cost to the DOW.

6. CLEARANCE

1. Visual Clearance:
  1. Pre-Work Inspection: Pre-work inspection shall be conducted jointly by the Competent Person and the IH after painted surface treatment and prior to the renovation of the project area. Clearance will be granted when the Competent Person and IH agree that the subsequent renovation will generate no visible emission of lead dust or debris.
  2. Final Visual Inspection: Final visual inspection shall be conducted by the Competent Person and the IH after renovation is completed and all debris is removed offsite. No visible paint chips or debris with paints shall remain.

7. DISPOSAL

1. Landfill Requirements: Landfill may require characterization of the waste generated from the project, where a representative sample is analyzed for analysis. Contractor shall provide required analyses to the landfill or other receiving parties.

1. Non-Hazardous Waste: If analytical results indicate the test results are within the EPA guideline or within the landfill acceptance criteria, the waste generated from the project can be disposed of as general construction and demolition (C&D) debris.
2. Hazardous Waste: If the test results exceed the landfill acceptance criteria, the waste shall be treated as hazardous waste and be disposed of in a Resource Conservation Recovery Act (RCRA) permitted landfill. Contractor shall contact DOW for EPA ID number.
3. Test Submittal: Contractor shall submit a copy of the waste characterization results to the DOW prior to request for EPA ID number. Hazardous Waste Manifest and Landfill Receipt shall be submitted prior to the final billing.

4. GENERAL

1. Waste Hauler Requirements: Waste is to be hauled by a transporter with required licenses from State and local authority with jurisdiction. Protect interior of truck or dumpster with Critical and Primary Barriers
2. Waste Loading and Labeling: Carefully load containerized or bagged waste in fully enclosed dumpsters, trucks or other appropriate vehicles for transport. Exercise care before and during transport, to ensure that no unauthorized persons have access to the material. If required by DOT, vehicles shall be marked with Department of Transportation placards.
3. Waste Storage: Do not store containerized or bagged waste outside of the work area. Take containers from the work area directly to a sealed truck or dumpster.
4. Waste Transport: Do not transport lead waste materials on open trucks. If waste material is to be transported in drums, label drums with the same warning labels as the bags.
5. Landfill Coordination: Coordinate with landfills in advance of transport and of the quantity of material to be delivered.
6. Waste Manifests: After completion of hauling and disposal of C&D waste and paint waste, submit a copy of waste manifest, chain of custody form (if applicable), and waste storage facility receipt to DOW. Final contract payment shall not be made until completed disposal documents are submitted.

7. RECORDKEEPING

1. Hazardous Waste Log: Complete and submit a copy of the Project Hazardous Waste Log to the DOW. See Appendix B of this Section.
2. Site Activities: Maintain accurate documentation of the site activities. Be prepared at all times to present real time information upon regulators' visits. Contractor's Competent Person shall be onsite at all times.

8. MEASUREMENT AND PAYMENT

Work performed under this Section shall not be measured or paid for separately, but shall be considered incidental to the lump sum price bid for the item of which it is a part in the Offer Schedule.

APPENDIX A

HAZARDOUS WASTE DISPOSAL LOG

NAME OF PROJECT:

Street Address:

City, State, Zip Code:

YEAR	DESCRIPTION OF HAZARDOUS WASTE	APPROXIMATE WEIGHT IN POUNDS	SPECIAL HANDLING
JANUARY			
FEBRUARY			
MARCH			
APRIL			
MAY			
JUNE			
JULY			
AUGUST			
SEPTEMBER			
OCTOBER			
NOVEMBER			
DECEMBER			

By \_\_\_\_\_ Signature

\_\_\_\_\_ Print Name

APPENDIX B  
PROJECT HAZARDOUS WASTE LOG  
(Contractor to complete one per facility site)

PROJECT: \_\_\_\_\_

COUNTY JOB NO. \_\_\_\_\_

START DATE: \_\_\_\_\_ COMPLETION DATE: \_\_\_\_\_

GENERAL CONTRACTOR: \_\_\_\_\_

ADDRESS: \_\_\_\_\_

TELEPHONE: \_\_\_\_\_ FAX NUMBER: \_\_\_\_\_

NAME OF SUPERINTENDENT FOR THIS PROJECT: \_\_\_\_\_

NAME OF GENERATOR (FACILITY): \_\_\_\_\_

ADDRESS: \_\_\_\_\_

TELEPHONE: \_\_\_\_\_ FAX NUMBER: \_\_\_\_\_

DESCRIPTION OF HAZARDOUS WASTE: \_\_\_\_\_

APPROXIMATE WEIGHT (IN POUNDS): \_\_\_\_\_

MONTHLY DISPOSAL LOG:

MONTH: \_\_\_\_\_ WEIGHT IN POUNDS: \_\_\_\_\_

MONTH: \_\_\_\_\_ WEIGHT IN POUNDS: \_\_\_\_\_

MONTH: \_\_\_\_\_ WEIGHT IN POUNDS: \_\_\_\_\_

DISPOSAL SITE: \_\_\_\_\_

CONTRACTOR DISPOSING OF HAZARDOUS WASTE: \_\_\_\_\_

ADDRESS: \_\_\_\_\_

TELEPHONE: \_\_\_\_\_ FAX NUMBER: \_\_\_\_\_

DISPOSAL CONTRACTOR IS A (CHECK ONE OF THE FOLLOWING):

CONDITIONALLY EXEMPT SMALL QUANTITY GENERATOR

SMALL GENERATOR

LARGE GENERATOR

APPROVAL:

STATE DESIGNATED COMPETENT PERSON: \_\_\_\_\_

COMPANY: \_\_\_\_\_

ADDRESS: \_\_\_\_\_

TELEPHONE NUMBER: \_\_\_\_\_

\_\_\_\_\_  
SIGNATURE

\_\_\_\_\_  
DATE

END OF SECTION

## SECTION SP-5 – REMOVAL AND DISPOSAL OF BULK MATERIAL CONTAINING PCB

### 1. GENERAL PROJECT DESCRIPTION

This Section specifies Contractor requirements when disturbing materials containing Polychlorinated Biphenyls (PCB). Contractor shall verify the locations and quantities of material that will be disturbed as part of the planned tank repair and related activities. Contractor shall ensure that employees and subcontractors involved in this project have access to the survey report and the specifications, and understand and control PCB hazards.

1. PCB-containing materials were confirmed in the subject tank as follows:

Beige coating on concrete floor of the tank, 28.4 milligrams per kilogram (mg/kg)

Beige asphaltic base sealant on concrete joint, 10.5 mg/kg (to be confirmed by Contractor)

Black coating on concrete walls of the tank interior, 114 mg/kg

2. Water contained in the tank has detectable levels of PCB. Remove and dispose of the water appropriately per requirements in SP-13.
3. The Contractor must conduct PCB related work in accordance with all applicable Federal, State, and Local regulations and requirements specified in the USEPA Conditional Approval of PCB Cleanup Plan and TSCA Risk-Based PCB Cleanup Approval Application.

### 4. REFERENCES

1. Publications: Publications listed below form a part of this specification. Publications are referred to in the text by the basic designation only. Federal requirements which govern PCB abatement work, hauling and disposal of PCB bulk product waste materials include, but are not limited to the following:

1. U.S. DEPARTMENT OF LABOR, OCCUPATIONAL SAFETY AND HEALTH ADMINISTRATION (OSHA): 29 CFR 1910.1000 Air Contaminants
2. U. S. ENVIRONMENTAL PROTECTION AGENCY (EPA):
  1. 40 CFR 61 National Emission Standards for Hazardous Air Pollutants
  2. 40 CFR 260 Hazardous Waste Management System, General
  3. 40 CFR 261 Identification and Listing of Hazardous Waste
  4. 40 CFR 262 Standards Applicable to Generators of Hazardous Waste
  5. 40 CFR 263 Standards Applicable to Transporters of Hazardous Waste
  6. 40 CFR 264 Standards for Owners and Operators of Hazardous Waste Treatment, Storage, and Disposal Facilities



7. 40 CFR 265 Interim Status Standards for Owners and Operators of Hazardous Waste Treatment, Storage, and Disposal Facilities
8. 40 CFR 268 Land Disposal Restrictions
9. 40 CFR 270 EPA Administered Permit Programs: The Hazardous Waste Permit Program
10. 40 CFR 273 Standards for Universal Waste Management
11. 40 CFR 761 Polychlorinated Biphenyls (PCBs) Manufacturing, Processing, Distribution in Commerce, and Use Prohibitions
12. 40 CFR 178 Specifications for Packagings
13. State Requirements: State requirements which govern hauling and disposal of hazardous waste materials include, but are not limited to:
  1. HIOSH - Toxic Materials and Harmful Physical Agents - Title 12, Subtitle 8, Chapter 202
  2. HIOSH - Access to Medical Records - Title 12, Subtitle 8, Chapter 145-12
  3. HIOSH - Hazard Communication - Title 12, Subtitle 8, Chapter 145-3
4. Local Requirements: Comply with local requirements which govern hauling and disposal of hazardous waste and universal waste.
5. Others
  1. USEPA Conditional Approval of PCB Cleanup Plan under TSCA 761.61(c) for Paua Valley Tank #1, Kekaha, Kauai, Hawaii, dated October 16, 2018
  2. TSCA Risk-Based PCB Cleanup Approval Application, Department of Water, Rehabilitate Paua Valley Tank #1, Kekaha, Kauai, Hawaii, dated September 18, 2018

### 3. DEFINITIONS

1. Amended Water: Water containing a wetting agent or surfactant.
2. Area Monitoring: Sampling of PCB concentrations within the PCB control area and outside the PCB control area, which is representative of the airborne concentrations of PCB in air, which may reach the breathing zone of personnel potentially exposed to PCB dust.
3. HEPA Filter Equipment: High Efficiency Particulate Air (HEPA) filtered vacuuming equipment with a UL 586 filter system capable of collecting and retaining PCB fibers. Filters shall be 99.97 percent efficiency for retaining fibers of 0.3 micrometers or larger.

4. Industrial Hygienist (IH): A third party industrial hygiene professional, retained by Contractor, to oversee the PCB compliance. The onsite work can be performed by an industrial hygiene technician (IHT). The IHT shall have hazardous material abatement project experience and shall be under the supervision of the industrial hygienist.
5. Local Exhaust System: A system in which static pressure in an enclosed control area is lower than that of the environment outside the control area, as specified herein.
6. Polychlorinated Biphenyls (PCB): PCB as used in this Section shall mean PCB, PCB containing bulk material, PCB contaminated material, and PCB container.
7. PCB Bulk Product Waste: Waste derived from materials that contain PCB at 50 mg/kg or greater.
8. PCB Control Area: An area where PCB removal operations are performed which is isolated by physical boundaries to prevent unauthorized entry of personnel and to prevent the spread of PCB dust or debris.
9. PCB Dust: Dust containing PCB.
10. PCB Permissible Exposure Limit: The limit is 1.0 mg/m<sup>3</sup> for PCB containing 42% chlorine, and 0.5 mg/m<sup>3</sup> for PCBs with 54% chlorine, for PCB-laden dust particles.
11. PCB Remediation Waste: Waste containing PCB as a result of the removal of bulk PCB-containing materials.
12. Personal Monitoring: Sampling of PCB concentrations within the breathing zone of an employee to determine the 8-hour time weighted average in accordance with Appendix A of 29 CFR 1926.1101. The samples shall be representative of the employee's work tasks. The breathing zone shall be considered an area within 12 inches of the nose or mouth of an employee.
13. Release: Release means both intentional and unintentional releases of dust and other uncontrolled discharges when the release results in any quantity of PCB dust to be expelled out of the containment area, as well as the contamination resulting from those releases.
14. Removal Encapsulant: A manufactured penetrating encapsulant or chemical peeler designed for coating removal.
15. Surfactant (Wetting Agent): A chemical wetting agent added to water to improve penetration. The surfactant shall be 50/50 mixture of polyoxyethylene ether and polyoxyethylene ester, or equivalent, mixed in a proportion of one fluid ounce to 5 gallons of water or as specified by the manufacturer. An equivalent surfactant shall be understood to mean material with a surface tension of 29 dynes/cm, as tested in accordance with ASTM D 1331.
16. Time Weighted Average (TWA): TWA is an 8-hour time weighted average of airborne concentration of PCB per cubic meter of air which represents the employee's 8-hour workday as determined by Appendix A of 29 CFR 1910.1001.

17. PCB REMOVAL

1. Total abatement of the bulk material (inner wall coating) containing PCB is anticipated. PCB work under this project generally includes materials that will be disturbed as part of this tank repair project and identified in the survey report. Removal or encapsulation of PCB shall be conducted prior to the tank rehabilitation work.
2. PCB material removal and disposal is governed by 40 CFR 761 PCB and 40 CFR 61 National Emission Standards for Hazardous Air Pollutants. Dispose of the PCB contaminated materials or waste consistent with all applicable TSCA PCB disposal requirements including and not limited to requirements in 40 CFR 761.62(a) and 40 CFR 761.205, "Notification of PCB Waste Activity".
3. In determining the disposal method for the waste, the Contractor must comply with the anti-dilution requirements in 40 CFR 761 (b). All bulk PCB remediation waste (i.e. oil, scum layer of the PCB impacted water in the tank) must be disposed of in accordance with the requirements in 40 CFR 761.61 (a)(5). The Contractor must select appropriate disposal facilities based on the in-situ PCB concentrations of the waste.
4. Cleanup waste (e.g. personal protective equipment, rags, gloves, booties) shall be disposed of in accordance with 40 CFR 761.61 (a)(5)(v). Disposal of all waste shall be in accordance with all Federal, State, and Local regulations.

5. SUBMITTALS

1. Submittals: Submittals shall be approved by the DOW representative, prior to commencing work involving PCB materials.
  1. PCB Bulk Material Removal Plan: Submit a detailed job-specific plan of the work procedures that will minimize airborne dust. Upon approval, all appropriate engineering controls shall be implemented in the removal of materials containing PCB.
  2. Plan shall Include:
    1. A clear scope of work for the Abatement Contractor
    2. Interface of trades involved in the rehabilitation of tank
    3. Sequencing of bulk (containing PCB) removal work
    4. Sampling and Analysis Plan including waste characterization
    5. Disposal plan for hazardous and non-hazardous waste
    6. Type of wetting agent or removal encapsulant or peeler to be used
    7. Equipment specifications and chemical Safety Data Sheets (SDS)
    8. Written Health and Safety Program

9. Written Hazard Communication Program (HAZCOM)
10. Current, valid training records for personnel who will conduct PCB disturbance activities.
11. Respiratory Protection Program with respirator fit test records
12. Respirators and protective equipment
13. A detailed description of the methods to be employed in order to control exposures and pollution
14. Emergency Procedures plan
15. A sketch showing the location, size, and details of PCB control areas, including clean and dirty areas, buffer zones, shower, storage areas, change rooms, 3-stage decontamination chamber, and removal methods.
16. Plan Approval: The PCB plan shall be approved by the DOW, prior to the start of PCB work. Prior to beginning work, Contractor shall meet with the DOW representative to discuss in detail the PCB plan, including notifications, work procedures, and safety precautions.
17. Landfill: Submit written evidence that the landfill is approved for PCB disposal by the State and local regulatory agencies. Within 3 working days after delivery, submit Hazardous Waste Manifest Form, prepared, signed, and dated by an agent of the landfill, certifying the amount of PCB materials delivered to the landfill.
18. Respiratory Protection Program: ANSI Z88.2 and 29 CFR 1910.134. Contractor shall submit a list of workers who are respirator-qualified. Information shall also include date and type of fit testing and manufacturer and size of respirator.
19. Permits, Licenses, and Certificates: Submit a copy of permits, licenses, certifications, inspection reports, releases, jurisdictional settlements, notices, receipts for fee payments, judgments, and similar documents, correspondence and records established in conjunction with compliance with standards and regulations bearing upon performance of the work including:
  1. Notices: Submit notices required by Federal, State, and local regulations with proof of timely transmittal to agency requiring the notice.
  2. Permits: Submit a copy of current valid permits required by State and local regulations and codes.
  3. Licenses: Submit a copy of State and local licenses necessary to carry out the work of this contract.
4. PCB Cleanup Report: The Contractor must submit a PCB cleanup report to DOW, to include all relevant data and justification demonstrating that the work completed is consistent with the USEPA Conditional Approval of PCB Cleanup Plan. The Contractor must address at a minimum all the reporting requirements set forth at 40 CFR 761.61(a)(9) and 40 CFR 761.125(c)(5).

5. NOTICES

1. Notifications: PCB work notification to EPA Region 9 is not required.

2. PERMITS AND LICENSES

Obtain and maintain current permits and licenses as required by applicable federal, state, or local jurisdictions for the removal, transporting, disposal or other regulated activity relative to the work of this contract.

3. POSTING AND FILING OF REGULATIONS

Post notices required by applicable Federal, State and local regulations. Maintain at least one (1) copy of applicable Federal, State, and local regulations and standards and approved work plan.

PART 2 – PRODUCTS

4. WETTING MATERIALS

1. PCB Wetting: For wetting prior to disturbance of PCB-containing materials, use either amended water, removal encapsulant, and or chemical peeler:

1. Amended Water: Provide water to which a surfactant has been added. Use a mixture of surfactant and water which results in wetting of the PCB containing material and retardation of trace fiber release during disturbance of the material equal to or greater than that provided by the use of one ounce of a surfactant consisting of 50% polyoxyethylene ester and 50% polyoxyethylene ether mixed with five gallons of water.

2. Removal Encapsulant and or Peeler: Provide a penetrating type encapsulant and or chemical peeler suitable for removal of PCB Material.

3. Health and Safety: During the preparation of the surface, all appropriate engineering controls shall be implemented to prevent worker exposures to PCB, trace asbestos fibers, and heavy metal lead. Review the hazardous material survey results for the findings and provide detailed worker protection measures in the Health and Safety Plan.

4. POLYETHYLENE SHEET

Provide a single polyethylene film in the largest sheet size possible to minimize seams, 6 mils thick, clear or frosted

5. DUCT TAPE

Provide duct tape in 2” or a 3” width as appropriate, with an adhesive, which is formulated to stick aggressively to sheet polyethylene.

6. SPRAY ADHESIVE

Provide spray adhesive in aerosol cans which is specifically formulated to stick tenaciously to sheet polyethylene.

7. DISPOSAL BAGS

Provide 6 mil thick leak-tight polyethylene bags labeled as required.

8. SIGNS

1. PCB Caution Signs: Post an approximately 20 inch by 14 inch manufactured caution sign at each entrance to the Work Area displaying the following legend with letter sizes and styles of a visibility required by 29 CFR 1926.1101. The PCB waste bags shall have the same caution label.

LEGEND

CAUTION  
CONTAINS  
PCB

CANCER HAZARD  
AUTHORIZED PERSONNEL ONLY

2. Line Spacing: Provide spacing between respective lines at least equal to the height of the respective upper line.
3. Sign Placement: Post an approximately 10 inch by 14 inch manufactured sign at each entrance to each Work Area displaying the following legend with letter sizes and styles of a visibility at least equal to the following:

LEGEND

NOTATION

NO FOOD, BEVERAGES OR TOBACCO PERMITTED

3/4" Block

ALL PERSONS SHALL DON PROTECTIVE

3/4" Block

CLOTHING (COVERINGS) BEFORE

ENTERING THE WORK AREA

ALL PERSONS SHALL SHOWER IMMEDIATELY

3/4" Block

AFTER LEAVING WORK AREA AND BEFORE

ENTERING THE CHANGING AREA

4. PART 3 - EXECUTION

5. EQUIPMENT

HEPA VACUUMING EQUIPMENT: Vacuuming equipment utilizing High Efficiency Particulate Air (HEPA) UL 586 filter system capable of capturing PCB dust.

6. AIR PURIFYING RESPIRATORS

1. Respirator Bodies: Provide half face, full face, or powered air purifying respirator (PAPR) type respirators.
2. Filter Cartridges: Provide, at a minimum, HEPA type filters labeled with NIOSH Certification for “Radionuclides, Radon Daughters, Dust, Fumes, Mists including PCB-Containing Dusts and Mists” and color coded in accordance with ANSI Z88.7 (2010). In addition, a chemical cartridge section may be added, if required for solvents, peeler, etc. In this case, provide combination cartridges labeled with the appropriate color code and NIOSH Certification.
3. Non-permitted respirators: Do not use single use, disposable or quarter face respirators.
4. Worker Requirements:
  1. Require that respiratory protection be used at all times that there is any possibility of disturbance of the tank inner wall coating materials whether intentional or accidental.
  2. Require that a respirator be worn by anyone in a Work Area at all times, regardless of activity, during a period that starts with any operation which could cause airborne dust until the area has been cleared for other trade.
  3. Regardless of Airborne Levels of PCB and Fibers: Require that the minimum level of respiratory protection used be half-face air-purifying respirators with high efficiency particulate air filters.
4. FIT TESTING
  1. Initial Fitting: Provide initial fitting of respiratory protection during a respiratory protection course of training. Fit types of respirator to be actually worn by each individual. Allow an individual to use only those respirators for which training and fit testing have been provided.
  2. On an Annual Basis: Check the fit of each worker’s respirator by having irritant smoke blown onto the respirator from a smoke tube. The fit test frequency shall be according to the OSHA requirement.
  3. Upon Each Wearing: Require that each time an air-purifying respirator is put on it be checked for seal with a positive and negative pressure fit check in accordance with the manufacturer’s instructions or ANSI Z88.2 (2015).
4. TYPES OF RESPIRATORY PROTECTION NEEDED
  1. Contractor Requirements: Provide Respiratory Protection as indicated in this Section. Higher levels of protection may be provided as desired by Contractor. Where paragraph below does not apply, determine the proper level of protection by dividing the expected or actual airborne fiber count in the Work Area by the “protection factors” given below.

Protection Factors

<b><u>RESPIRATOR TYPE</u></b>	<b>PROTECTION FACTOR</b>
Air purifying: Negative pressure respirator High efficiency filter Half or full facepiece	10
Powered Air Purifying Respirator (PAPR): Negative pressure respirator High efficiency filter Full facepiece	50
Type C supplied air: Positive pressure respirator Pressure demand Full facepiece	1,000
Type C supplied air: Positive pressure respirator, pressure demand Full facepiece equipped with an auxiliary positive pressure Self-Contained Breathing Apparatus (SCBA)	over 1,000

2. Respirator Use: Use the following as a minimum unless air monitoring results indicate greater protection is necessary. Refer to Protection Factors table for choice of respirators.

1. Containment or barrier installation which does not disturb PCB: Dual Cartridge, Half-face Air Purifying Respirators.
2. Removing or cleaning items or barrier installation when such operation may disturb PCB: Dual Cartridge, Half-face Air Purifying Respirators.
3. Wall coating with PCB Removal: Dual Cartridge, Half-face Air Purifying Respirators.
4. Gross Cleaning of Removal Area(s): Dual Cartridge, Half-face Air Purifying Respirators.
5. Final Wet-Cleaning of Area Until Final Air Tests Show Exposure In Work Areas to be below 0.5 mg/m<sup>3</sup>: Dual Cartridge, Half-face Air Purifying Respirators.
6. Loading and Unloading Drums On Truck (outside work area): Dual Cartridge, Half-face Air Purifying Respirators.

7. **PROTECTIVE CLOTHING**

Furnish personnel exposed to airborne concentrations of PCB greater than or equal to the permissible exposure limit with disposable protective whole body clothing, head covering, gloves, and foot coverings. Furnish disposable plastic or rubber gloves to protect hands. Cloth gloves may be worn inside the plastic or rubber gloves for comfort, but shall not be used alone. Use tape to secure sleeves at the wrists and to secure foot coverings at the ankles.

8. **PERSONNEL DECONTAMINATION UNIT**



Provide a decontamination area adjacent to the work area, as applicable. Decontamination area will consist of a polyethylene sheet placed adjacent to the work area large enough for employees to remove disposable coveralls and shower prior to exiting the work area. Waste generated during decontamination will be disposed of as PCB bulk product waste. At the conclusion of work the plastic sheet will be disposed of as PCB bulk waste. Position a HEPA vacuum at the decontamination unit which workers will use to clean off protective clothing prior to removal.

9. CLEANING OF DECONTAMINATION UNITS

Clean debris and residue from the Decontamination Area on a daily basis. Damp wipe or hose down all surfaces after each shift change. All waste and rinse water shall be captured and contained before proper disposal.

10. WORK PROCEDURE

Conduct PCB-related work in accordance with 40 CFR 761, 40 CFR 61, and as specified herein. Use controlled removal procedures. Personnel shall wear and use protective clothing and equipment as specified in the approved Work Plan. Eating, smoking, or drinking shall not be permitted in the PCB control area or change room. Personnel of other trades not engaged in the removal of the tank coating with PCB shall not be exposed at any time to airborne concentrations of PCB greater than or equal to 0.5 mg/m<sup>3</sup>, unless the personnel protection provisions of this Section are complied with by the trade personnel.

11. PCB CONTROL AREA REQUIREMENTS

1. Perimeter: Provide a marked perimeter around the work area during the tank wall coating removal operations. No one will be permitted in the PCB control area unless the person is provided with appropriate training and protective equipment (respirators and coveralls). During the coating removal operation, should the PCB abatement employees need to exit the controlled area, they shall remove their disposable coveralls, place them in an approved impermeable disposal bag, and then exit the area.
2. Personal Air Sampling During Work: Conduct personal air monitoring samples on 25% of the work crew or a minimum of two employees whichever is greater during each work shift.
3. Area Air Sampling During Work: Industrial Hygienist (IH) retained by Contractor will conduct boundary samples upwind and downwind of the PCB control area during each work shift. If the concentration of airborne PCB at the boundaries is greater than or equal to 0.5 mg/m<sup>3</sup> of air, or background quantity whichever is greater, Contractor shall stop work, and correct the condition(s) causing the increase. If adjacent areas are contaminated, the contaminated areas shall be cleaned and visually inspected by the IH and Contractor's Competent Person. IH shall certify that the area has been cleaned of PCB contamination.
4. IH shall not be paid by Abatement Contractor.

5. PCB HANDLING PROCEDURES

1. General Procedure: Remove coating material in a controlled manner and immediately place in approved impermeable bags or containers. Collect PCB waste, scrap, debris,

bags, containers, equipment, and PCB-contaminated clothing and place in sealed impermeable bags constructed of 6-mil plastic sheet.

2. Container Labeling: Provide PCB caution labels on sealed impermeable bags and PCB waste containers. When applicable, use a lined chute, hoist, lift or other DOW-approved method to move double-bagged PCB containing waste material out of tank to PCB waste transport container. If chute is used, it must be affixed with a negative pressure unit to minimize airborne PCB concentrations.

### 3. AIR MONITORING

1. Work Area Airborne Fiber Levels: IH retained by Contractor will monitor airborne concentrations of PCBs in the Work Area, as applicable. The purpose of this air monitoring will be to detect potential airborne PCB concentrations inside and outside of the control area.
2. Outside the Work area (Barrier) Fiber Levels: IH will assess airborne fiber levels outside the work area to determine if leakage is occurring outside of the control area.

1. IH will conduct visual and air monitoring throughout the project.
2. Contractor is responsible for his/her worker protection and personal air monitoring and legally-required documentations.

### 3. STOP ACTION LEVELS

1. Inside Work Area: Maintain airborne levels in the work area of less than 0.5 mg/m<sup>3</sup>. If PCB concentration levels rise above this figure for any sample taken, revise work procedures to lower concentrations. If levels for any work shift or 8 hour period exceeds the Stop Action Level, stop work except corrective action and leave air circulation system in operation.
2. Outside Work Area: If any air sample taken outside of the Work Area exceeds the baseline established prior to start of work, immediately and automatically stop work except corrective action. Contractor shall determine the source of the high reading and take appropriate corrective actions.

If the high reading was the result of a failure of Work Area isolation measures, initiate the following actions:

1. Decontaminate the affected area(s).
  2. Require that respiratory protection be worn in affected the area until the area is cleared for other trade or reoccupancy.
  3. If the high reading was the result of other causes, initiate corrective action as determined by the Competent Person and the IH. Any costs incurred due to the delay caused by corrective actions and verification sampling and analysis shall be borne by the Contractor.

### 4. ANALYTICAL METHODS

The following methods will be used in analyzing filters used to collect air samples. The filters used shall be in accordance with the referenced methods.

Method based on NIOSH Method 5503

5. SAMPLE VOLUMES

Number and volume of air samples taken by the IH will be in accordance with the following schedule. Sample volumes given may vary depending upon the analytical method used and Contractor method of removal.

6. BASELINE

IH will secure the following air samples to establish a baseline before start of PCB removal work:

LOCATION SAMPLED	NUMBER OF SAMPLES MINIMUM	MAXIMUM VOLUME (LITERS)	RATE (LPM)
Each Work Area	1 for up to 5000 sq.ft.; one additional per each additional 5000 sq.ft.	50	0.05 – 0.2
Outside the Work Area	1	50	0.05 – 0.2

7. DAILY

1. Sample Collection: From start of work and as applicable, IH will take the following samples during removal of PCB:

SAMPLE TYPE SAMPLE LOCATION	MINIMUM NUMBER OF SAMPLES	MINIMUM SAMPLE VOLUME (LITERS)	SAMPLE FLOW RATE (LPM)
Work Area – Each Work Area	1 per shift	50	0.05 – 0.2
Barrier – Area Upwind	1 per shift, unless sample area is dusty; then increase number as necessary	50	0.05 – 0.2
Barrier – Area Downwind	1 per shift, unless sample area is dusty; then increase number as necessary	50	0.05 – 0.2
Field Blanks	2 – 10 field blanks per set of samples	NA	NA

2. Additional Sampling: Additional samples may be taken at the IH’s and DOW’s discretion. If airborne concentrations exceed allowed limits, additional samples shall be taken as necessary to monitor airborne levels of PCB and other stressors. Personal monitoring performed by the IH shall not remove the Contractor’s responsibility to monitor his/her workers’ health & safety and required documentations.

3. AIR SAMPLING MEDIA

Sample Cassettes: Samples will be collected on 13 mm. glass fiber + Florisil, 100 mg/50mg.

4. LABORATORY TESTING

1. Area Air Sampling Results: Services of a testing laboratory will be employed by the IH to obtain area air samples as indicated. IH will obtain samples daily. PCB air sample results will be obtained within 24 hours of sample submittal. Contractor and DOW will have access to air monitoring tests and results.
2. Personal Air Sampling Results: Contractor is responsible for laboratory analysis for the personal air monitoring. Results shall be made available within 24 hours of sample submittal.

3. CLEANUP AND DISPOSAL

1. Cleanup: Maintain the PCB control area free of accumulations of PCB dust. Restrict the spread of dust and debris; keep waste from being distributed over the general area. Do not dry sweep or blow down the space with compressed air. When PCB removal, disposal, and cleanup are complete, the IH will certify, in writing, that the work was performed in accordance with applicable OSHA and EPA regulations and contract specifications.
2. Visual Inspection: Competent Person and the IH will visually inspect the affected surfaces for residual PCB containing material and accumulated dust before and after the removal of the PCB control area; Contractor shall reclean areas showing dust or residual PCB materials. If recleaning is required, monitor the PCB airborne concentration during and after recleaning.
3. PCB Clearance Criteria: IH retained by Contractor shall conduct PCB work area clearance. Upon removing the existing PCB containing coating materials but prior to applying new coating, the IH shall collect wipe samples from the interior tank surface. A minimum one sample per an area with 10 ft x 10 ft shall be taken to ensure that the surfaces have been properly decontaminated to 5 µg/100 cm<sup>2</sup> or less of PCB. Following recoating of the tank, the IH shall collect wipe samples from the finished tank surface with a minimum one sample per an area with 10 ft x 10 ft. PCB shall not be detected from the new tank surface. Upon refilling the tank with water, the Contractor shall sample water from the tank at the entry point to the distribution system. The testing results must be not-detected with a reporting limit of 0.5 micrograms per liter (µg/L) or less of PCB.
4. Disposal of PCB: Dispose of waste material containing PCB at a State and or EPA approved landfill. Procedure for hauling and disposal shall comply with 40 CFR 761, and State and local regulations and codes. Sealed and labeled impermeable bags may be dumped from transport vehicles into the burial site unless bags have been broken or damaged. Damaged bags shall be repaired or rebagged, or transported in suitable containers or drums. Uncontaminated drums may be recycled. Contractor's and landfill's workers loading and unloading PCB waste bags shall wear appropriate respirators and personal protective equipment.

5. Waste Shipment Records: Prior to delivery of PCB waste materials, Contractor shall complete the EPA's Waste Shipment Records requirements on manifesting PCB waste removal, transportation, and final disposal. Payment for this Section will not be made until a completed manifest from the disposal facility is returned, and a copy furnished to DOW. Copy and instructions for Waste Shipment Record are attached at the end of this Section.
6. Submit a PCB Cleanup Report within 30 calendar days of completing work at the site.
7. MEASUREMENT AND PAYMENT

Work involving removal and disposal of materials containing PCB and demolition debris shall not be measured or paid for separately, but shall be considered incidental to the lump sum price bid for the item of which it is a part in the Offer Schedule.

ENTRY LOG  
(Sample Visitor Log)

DATE:

PROJECT:

SUPERVISOR:

---



---



---

ALL PERSONNEL MUST SIGN-IN AND SIGN-OUT EVERY TIME THEY ENTER/EXIT THE WORK AREA. PLEASE PRINT CLEARLY. ATTACH EMPLOYEE RELEASE FORM FOR ALL VISITORS.

Name	Employer Name, address*, phone*	Time in	Time out	Purpose of visit	Type of PPE issued**

\*Not required of Contractor's employees.

\*\*Type of PPE (Personal Protective Equipment) issued to include list of protective clothing worn and type of respirator used (Type "C," half-face dual cartridge, etc.)

Note:
-------

EMPLOYEE RELEASE FORM  
(Sample)

Employee Name:

Employee Address:

Employee Telephone No.:

Name of Training center, Certificate Number and expiration Date:

Classification of work:

Have you had in the past or present, any respiratory problems?

Yes

No

Have you worked in the past with PCB-containing materials?

Yes

No

The project you will be working on involves the use of PCB and the removal of the PCB from the structure. PCB is considered a health hazard.

The company is supplying all necessary safety clothing and working conditions required and necessary for your protection from PCB hazard.

You shall be instructed at the commencement of the job on the required use of safety equipment, clothing, working conditions, and procedures. These must be rigidly adhered to. Smoking is not permitted in the work area. Disregarding of safety instructions shall result in instant dismissal.

I acknowledge that safety instructions have been given to me by the company at my work commencement and I am thoroughly conversant with them and I have answered the above questions truthfully.

\_\_\_\_\_  
Signed (Employee)

\_\_\_\_\_  
Date

\_\_\_\_\_  
Print name

CERTIFICATE OF WORKER'S ACKNOWLEDGEMENT

PROJECT NAME: \_\_\_\_\_ DATE: \_\_\_\_\_  
PROJECT ADDRESS: \_\_\_\_\_

CONTRACTOR: \_\_\_\_\_

WORKING WITH PCB CAN BE DANGEROUS. INHALING PCB DUST HAS BEEN LINKED WITH VARIOUS TYPES OF CANCER. IF YOU SMOKE AND INHALE PCB DUST THE CHANCE THAT YOU WILL DEVELOP LUNG CANCER IS GREATER THAN THAT OF THE NON-SMOKING PUBLIC.

Your employee contract with the Owner for the above project requires that: You be supplied with the proper respirator and be trained in its use. You be trained in safe work practices and in the use of the equipment found on the job. You receive a medical examination. These things are to have been done at no cost to you.

RESPIRATORY PROTECTION: You must have been trained in the proper use of respirators, and informed of the type respirator to be used on the above referenced project. You must be given a copy of the written respiratory protection manual issued by your employer. You must be equipment at no cost with the respirator to be used on the above project.

TRAINING COURSE: You must be trained in the dangers inherent in handling PCB and breathing PCB dust and proper work procedures and personal and area protective measures. The topics covered in the course must have included the following:

- Physical characteristics of PCB
- Health hazards associated with PCB
- Respiratory protection
- Use of protective equipment
- Pressure Differential Systems
- Working practices include hands on or on-job training
- Personal decontamination procedures
- Air monitoring, personal and area

MEDICAL EXAMINATION: You must have had a medical examination within the past 12 months at no cost to you. This examination must have included: health history, pulmonary function tests and may have included an evaluation of a chest X-ray.

By signing this document you are acknowledging only that the Owner of the building you are about to work in has advised you of your right to training and protection relative to your employer, the Contractor.

Signature \_\_\_\_\_ Social Security No. \_\_\_\_\_

Print Name \_\_\_\_\_ Witness \_\_\_\_\_



PCB DISPOSAL FORM (Sample)

GENERATOR	1. WORK SITE NAME & MAILING ADDRESS	OWNER'S NAME	OWNER'S TELEPHONE NO.
	2. OPERATOR'S NAME & ADDRESS		OPERATOR'S TELEPHONE NO.
	3. WASTE DISPOSAL SITE (WDS) NAME, MAILING ADDRESS, AND PHYSICAL SITE LOCATION		WDS TELEPHONE NO.
	4. NAME AND ADDRESS OF RESPONSIBLE AGENCY		
	5. DESCRIPTION OF MATERIALS	6. CONTAINERS NO.      TYPE	7. TOTAL QUANTITY M <sup>3</sup> (YD <sup>3</sup> )
	8. SPECIAL HANDLING INSTRUCTIONS AND ADDITIONAL INFORMATION		
	9. OPERATOR CERTIFICATION: I HEREBY...		
PRINTED/TYPED NAME & TITLE	SIGNATURE	DATE (MO/DY/YR)	
TRANSPORTER	10. TRANSPORTER 1 (ACKNOWLEDGEMENT OF RECEIPT OF MATERIALS)		
	PRINTED/TYPED NAME & TITLE	SIGNATURE	DATE (MO/DY/YR)
	11. TRANSPORTER 2 (ACKNOWLEDGEMENT OF RECEIPT OF MATERIALS)		
	PRINTED/TYPED NAME & TITLE	SIGNATURE	DATE (MO/DY/YR)
DISPOSAL SITE	12. DISCREPANCY INDICATION SPACE		
	13. WASTE DISPOSAL SITE OWNER OR OPERATOR: CERTIFICATION OF RECEIPT OF PCB MATERIALS COVERED BY THIS MANIFEST EXCEPT AS NOTED IN ITEMS 1, 2, AND 3.		
	PRINTED/TYPED NAME & TITLE	SIGNATURE	DATE (MO/DY/YR)

END OF SECTION

## SECTION SP-6 – TESTING/AIR MONITORING

### PART 1 - GENERAL

#### 1. GENERAL PROJECT DESCRIPTION

1. This Section describes Contractor's responsibility for compliance while conducting work which disturbs asbestos-containing materials (ACM), lead-containing paint (LCP), and material containing polychlorinated biphenyls (PCB). Related sections are:

1. SECTION SP 3: REMOVAL AND DISPOSAL OF MATERIAL CONTAINING ASBESTOS for requirements of work which disturbs materials containing asbestos.
2. SECTION SP 4: LEAD HAZARD CONTROL for requirements of work which disturbs lead-containing paint.
3. SECTION SP 5: REMOVAL AND DISPOSAL OF BULK MATERIAL CONTAINING PCB for requirement of work which disturbs PCB-containing coating and bulk materials.

4. Engineering Controls: Implement appropriate engineering controls and safety measures to prevent site workers, facility users, other trades, the public, and the environment from exposure to hazardous materials.

5. Cost Responsibility: Costs incurred due to Contractor inability to control hazards shall be borne by Contractor, including but not limited to, investigations, medical, legal, regulatory and public relations, clean-up, monitoring, and reporting.

6. Monitoring: An independent industrial hygiene (IH) firm, retained by Contractor, will conduct the monitoring during the Contractor's work which disturbs hazardous materials. IH firm shall have no affiliation with Abatement Contractor.

#### 7. GENERAL REQUIREMENTS

1. Contractor Responsibilities. Testing and workers' breathing zone monitoring shall be conducted by the Contractor for the purpose of:
  1. Verifying compliance with the applicable codes, regulations and laws regarding hazardous material abatement.
  2. Ensuring that the legally-required documentation is collected in a timely manner.
  3. Providing engineering controls during project.

#### 4. TESTING/ AIR MONITORING/ INDUSTRIAL HYGIENE SUPERVISION AND AIR MONITORING

1. Air Monitoring: Industrial hygiene and air monitoring shall be performed by an independent IH firm retained by Contractor. The laboratory used for sample analysis

shall be proficient in the National Institute for Occupational Safety and Health (NIOSH) Proficiency Analytical Testing (PAT) program.

2. Air Monitor Qualifications:

1. Industrial hygiene and air monitoring will be conducted under the direction of a Certified Industrial Hygienist (CIH) or a professional engineer (PE) who has minimum 5 years of experience in hazard abatement project management. On-site monitoring may be conducted by a competent and qualified IH Technician with a minimum of 2 years of relevant experience in hazardous material abatement, provided activities are conducted under the supervision of the CIH.
2. Aforementioned industrial hygiene and air monitoring shall not remove the Contractor's responsibility for his/her worker protection and required documentations.

3. COORDINATION WITH OTHER SECTIONS

Testing and monitoring requirements included in the scope of work for any testing/air monitoring consultants or inspectors shall be coordinated with: SECTION SP 2 – REMOVAL AND DISPOSAL OF MATERIAL CONTAINING ASBESTOS; SECTION SP 3 – LEAD HAZARD CONTROL; SECTION SP 4 – REMOVAL AND DISPOSAL OF BULK MATERIAL CONTAINING PCB.

4. PART 2 – PRODUCTS

Not applicable to this section.

5. PART 3 - EXECUTION

6. COMPETENT PERSON RESPONSIBILITIES

1. Work Plans: Contractor's Competent Person shall prepare an Asbestos Removal and Disposal Plan per Section SP 3 Paragraph F, b; a Lead Hazard Control Plan per Section SP 4 Paragraph K, 1; and a Bulk Material containing PCB Removal Plan per Section SP 5 Paragraph E, 1, b. State certifications and training records shall be valid and reflect the anticipated workers on site.
2. Waste Disposal: Submit a proof of waste characterization and disposal documents. In the event that the waste is determined to be hazardous, inform DOW representative and obtain EPA ID number from DOW.
3. Section Reference: Refer to Sections SP 3, SP4, and SP5, and part K, below, for additional responsibilities.

4. CONTRACTOR RESPONSIBILITIES

1. Work Plan Submittal: Submit complete work plans for review and concurrence by DOW. Refer to Section SP 3, SP 4, and SP 5 for requirements of the work plan.

2. Records: Maintain worker monitoring and necessary records for the Contractor's employees as required by OSHA (29 CFR 1926.58), Hawaii Administrative Rules, and other applicable laws.
  3. Respiratory Protection: Obtain legally required documentation for air monitoring and submit a written respiratory protection program as part of the contract.
  4. Additional Costs: Additional costs involving investigations, air monitoring, legal, medical, regulatory and public relations, testing, and reporting due to Contractor's inability to control hazards shall be borne by Contractor and shall be deducted from the final contract payment.
  5. Additional Testing by the IH: Accommodate additional testing performed by the IH; however, this shall not remove Contractor's responsibility of monitoring required by law and contract specifications.
  6. Final Cleanup (General): For final cleanup and decontamination, remove the final polyethylene sheeting, or drop cloth, but leave the coverings for critical barriers until successful clearance is obtained.
  7. Asbestos Clearance by Visual Inspection: IH retained by Contractor and Contractor's Competent Person shall jointly conduct visual inspection, and the IH shall conduct air clearance, by phase contrast microscopy (PCM), prior to releasing the space to other trades. Five interior, five exterior, two blank, and one lot blank PCM samples shall be collected.
  8. Lead Clearance by Visual Inspection:
    1. Final Visual Inspection: IH retained by Contractor and the Contractor's Competent Person shall conduct the final visual inspection.
    2. There shall be no visible emissions of lead paint debris or dust.
  3. PCB Clearance by Concrete Substrate and Water Sampling: IH retained by Contractor shall conduct PCB work area clearance. Upon removing the existing PCB containing coating materials but prior to applying new coating, the IH shall collect five concrete samples from the five different locations in the interior tank. Upon refilling the tank with water, the Contractor shall sample water from the tank at the entry point to the distribution system. The testing results result must be not-detected with a reporting limit of 0.5 micrograms per liter ( $\mu\text{g/L}$ ) or less of PCB.
4. MONITORING AND INSPECTION BY COMPETENT PERSON
1. Duties of the Competent Person. The Competent Person shall conduct the following:
    1. Photographic Record of Project: Record work with representative photos. Photos shall become the property of DOW and are to be accompanied by a detailed log.
    2. Project Log: Competent Person shall be on site at all times and maintain daily field logs detailing key activities during ACM-, LCP-, and PCB-related work and

submit a summary of project activities to the DOW within 10 days of abatement completion. Incorporate daily field reports with other project data into the final closeout report.

3. Visual Inspection of Controlled Areas: Conduct inspections of controlled areas, during the actual work performance, to document the work practices employed. Verify that scheduled abatement or mitigation work is completed, and the area was properly and promptly cleaned and ready for the final visual inspection and relevant clearance testing.
4. Change Order: If changes are necessary once construction begins, review request for change and make a recommendation for approval. Per Section SP 3 Paragraph KK, SP 4 Paragraph GG, and SP 5 Paragraph JJ, removal activities and disposal of wastes will not be measured or paid separately, except for previously unforeseen hazardous waste determined by the waste characterization (Section SP 4 Paragraph DD).
5. Site Monitoring by Competent Person. The Competent Person shall ensure:
  1. Personal Air Monitoring. Onsite personnel air monitoring as required by OSHA, and the project specifications
  2. Decontamination Monitoring. Monitoring of decontamination procedures at control area entry/exit and of cleanup after each shift
  3. Control Areas. Monitoring of controlled area maintenance and waste handling
  4. Communication. Interface with IH, Designer of Records, representatives of regulatory agencies, and the DOW representative
  5. Training, Controls, and Respiratory Protection. Ensure workers are trained, and proper engineering controls and respiratory protection are utilized by personnel within control areas
  6. Discrepancies. Relay to DOW representative any discrepancies in Contractor's action with provisions of project specifications. All deviations from the approved Work Plan shall be evaluated and concurred by DOW prior to implementation.
7. TESTING/AIR MONITORING
  1. IH Authority: IH retained by Contractor shall have authority to stop work or to exercise engineering controls during the project.
  2. Additional Testing: IH may conduct additional testing and air monitoring at his/her discretion.
  3. Submittal of Documents: Monitoring activities will be documented and submitted to DOW with test results, interpretations, follow-up actions, and final resolutions.

4. SAMPLE DESIGN

Sampling During Work: The following is a typical sampling design per control area during the construction. Number of sample quantities and volume may vary.

1. BACKGROUND SAMPLES: Background baseline samples shall be taken prior to ACM and PCB work to establish pre-removal airborne concentration levels. Continuous flow samples will be taken for anticipated control area. Work area samples shall be analyzed by the NIOSH 7400 method for asbestos and NIOSH 5503 method for PCB.
2. WORK AREA SAMPLES: Low volume samples of a maximum of 480 liters each shall be taken in the work area for airborne asbestos and lead, and 50 liters for airborne PCB. Ambient air samples shall be taken outside of work area to assess and ensure that engineering controls are effective and that the persons entering the work area are properly protected from airborne hazards. If monitoring results inside and outside the controlled area indicate airborne concentrations is greater than 0.01 f/cc for asbestos, 30  $\mu\text{g}/\text{m}^3$  air for lead, and 0.5  $\text{mg}/\text{m}^3$  for PCB, Contractor shall correct the condition(s) causing the increase and ensure that Contractor maintains the ambient conditions to below the action levels.
3. BARRIER SAMPLES: As applicable, two samples may be taken per barrier, any engineering controls using plastic sheeting or canvas, etc., to prevent the spread of the contaminated debris or dust.
4. ENVIRONMENTAL SAMPLES: The removal area shall be controlled so that airborne dust cannot escape outside the controlled area. Per the IH's discretion, high volume or low volume samples per controlled area will be taken.
5. MEASUREMENT AND PAYMENT

Work involving worker monitoring, waste characterization, and OSHA and EPA compliance shall not be measured or paid for separately but shall be considered incidental to the lump sum price bid for the item of which it is a part in the Offer Schedule.

END OF SECTION

## SECTION SP-7 – CONCRETE REPAIR

### 1. GENERAL

1. Description: This item of work shall include the furnishing of all labor, materials, tools and equipment necessary for completing the concrete repair work including spalls, cracks, exposed reinforcing and scaling as described or shown in the construction documents and in accordance with Water System Standards, 2002, as amended hereafter, and as they apply to this project and as shown on the drawings.
2. Submit product data information or certificates of conformance for repair products demonstrating products meet the stated requirements.
3. Deliver and store products at job site in original packaging with product labels and information. Do not use any product that has been damaged or changed by exposure to the elements prior to use or are beyond expiration dates.
4. All reservoir wall concrete repair work shall not be performed until the reservoir water has been completely drained. Coordinate the downing of the reservoir with the DOW. Prior to the downing of the reservoir, the Contractor shall secure the required NPDES permits and applicable State and County discharge permits to properly dispose of the contaminated reservoir water, see Section SP-13.

### 1. RESERVOIR WALL CRACK REPAIR

- A. Identification Criteria: Cracks shall be repaired by the method described in this subsection if the crack is on a vertical or inclined surface and greater than 0.06 inch wide. No repair is required for cracks on a vertical surface smaller than 0.06 inches wide.
- B. Reservoir Exterior Repair: Crystalline waterproofing mortar in routed groove along surface crack with a strengthening finish coat of crystalline product.
  1. The crack shall be routed out along the length of the crack to the depth specified by manufacturer or to sound concrete, whichever is greater.
  2. The exposed surface of the routed surface shall be scrubbed with crystalline waterproofing mortar slurry to coat surface.
  3. Only enough water shall be added to the crystalline mortar to form a dry pack consistency. The groove shall be packed with the grout flush with the surface of the wall and coated with a crystalline reinforcing finish coat (if recommended by manufacturer) extending beyond the width of the groove as detailed followed by a curing method as recommended by the manufacturer.
  4. Acceptable crystalline waterproofing products and manufacturers:
    - a. “Aquafin-IC” by Aquafin Building Product Systems, Elkton, MD (866) 278-2346
    - b. “Concentrate” by Xypex Chemical Corp., Richmond, British Columbia, Canada (800) 961-4477
    - c. Approved Equal
  5. Acceptable crystalline reinforcing finish coat products and manufacturers:
    1. “Mortar-IC” by Aquafin Building Product Systems, Elkton, MD (866) 278-2346
    2. “Modified” by Xypex Chemical Corp., Richmond, British Columbia, Canada (800) 961-4477

3. Approved Equal

- C. Leaking Crack Interior Repair: Cracks shall be repaired by the method described in Section 7.02.B if the crack is leaking or shows signs it had leaked in the past.

2. SPALL AND SCALING REPAIR

Concrete spall or scaled areas shall be repaired by the following method, if a leaking crack is located within a spall area, the crack shall be repaired as specified above in Section 7.02 prior to repairing the spall.

1. Non-Reservoir Repair: Rust Inhibitor bonding agent shall be a multi-component, solvent-free, moisture-tolerant, epoxy-modified, cementitious product specifically formulated as a bonding agent with anti-corrosion properties, such as “Sika Armatec 110 EpoCem” by Sika Corp and “Rebar Primer and Bonding Agent” by ThoRoc or approved equal. The product shall be used in any locations where corrosion or reinforcing bars is evident or the concrete repair area exposes any reinforcing steel. The bonding agent shall be applied over the entire repair area, not just on the exposed reinforcing steel in accordance with the manufacturer’s recommendations. A second coat shall be applied to the reinforcing steel surface.
  2. Reservoir Repair: Use same patch material, and scrub a thick pourable slurry into the prepared substrate and reinforcing steel surface. Apply repair mortar prior to scrub coat drying. If scrub coat dries prior to application of repair mortar, follow manufacturer’s recommendations to remedy the condition.
  3. Patch material shall be a two-component, polymer-modified, cementitious, trowel-grade mortar with a 7-day compressive strength determined by ASTM C 109 of 4,500 psi minimum and a bond strength per ASTM C 882 (modified) of 2,000 psi minimum at 28-days, such as “SikaTop 122 PLUS” by Sika Corp. or approved equal. Only products that have NSF 61 for potable water contact shall be used for repair work on reservoir walls or roof slabs.
1. Apply repair mortar as recommended by manufacturer, do not exceed single lift thickness limit stated in product information.
  2. Extend mortar with clean sand meeting recommendations of manufacturer, if permitted by manufacturer when depth of repair exceeds limit of neat application.
  3. Strike-off surface of repair flush with surrounding surface working from center of repair towards the edge and cure as recommended by product manufacturer.
  4. Cure repair area as specified in Section 303.03(R) of the Water System Standards.
  4. If corrosion of any reinforcing steel is observed where more than 1/4 of the bar area has been affected, contact the Officer-in-Charge for direction on how to proceed.

7.04. REPLACE FORM TIE HOLE PLUGS

- A. Identification Criteria: Tie holes plugs shall be replaced by the method described in this subsection if the plug is missing, loose or displaced (backing out of the original hole),



regardless of whether it is loose or not, shall be replaced as described below and detailed in the Project Drawings.

- B. If any metal object is exposed, it shall be cut back from the surface of the exterior wall face a minimum of 1 inch and coated with an approved bonding agent prior to patching the tie hole.
- C. Prepare surface to be repaired as recommended by product manufacturer.
- D. Coat inside surface of tie hole with approved bond agent, the same as described above for spall repair in Section 7.03.A and apply patch material within specified time period specified for bonding agent.
- E. Patch the form tie hole with approved cementitious mortar repair material as described above for spall repair in Section 7.03.B.
- F. Cover repaired patch with a vapor barrier sheet and tape to surface of wall to cure for a minimum of 5 days.

#### 7.05. REPAIR OF MINOR CRACK ON HORIZONTAL SURFACE

- A. Identification Criteria: Cracks shall be repaired by the method described in this subsection if the crack is on a horizontal surface and greater than a hairline crack (0.02 inch wide), but does not meet the criteria set for reservoir wall crack repair of Section 7.02.A.
- B. Minor cracks occurring on a horizontal surface shall be repaired with a two-component, low viscosity, moisture-tolerant, crack healer epoxy resin that does not create a vapor barrier with a minimum bond strength at 2 days of 2,500 psi (ASTM C 882) with NSF 61 Standard certification, such as “Sikadur 55 SLV” by Sika, or approved equal.
  - 1. Prepare surface to be repaired as recommended by product manufacturer.
  - 2. Mix components of product as recommended and apply at the recommended rate working into the cracks with a broom or flat squeegee. Allow product to pond over cracks. Remove excess material, leaving no visible surface film.

#### 1. REMOVAL AND REPAIR OF EMBEDDED FASTENERS

- 1. Remove fastener to a depth at least one inch below the concrete surface.
- 2. Prepare exposed surface of concrete removed in order to remove fastener, per patch material manufacturer’s instructions.
- 3. Coat exposed surface of cut fastener with bonding agent with anti-corrosion properties, the same as described above for spall repair in Section 7.03.C.
- 4. Scrub surface repair surface with slurry of the repair mortar as described in manufacturer’s instructions.
- 5. Apply approved cementitious mortar repair material as described above for spall repair in Section 7.03.C in area to be repaired per manufacturer’s instructions.

6. Cure patch area per manufacturer's instructions by covered with a curing blanket held in place with adhesive tape for the curing period recommended or 5 days if not specified in manufacturer's instructions.

7. PAYMENT

Payment for the CONCRETE REPAIR work shall be made for the various items at the respective unit prices and agreed upon quantities or Lump Sum Bid. Payment shall represent full compensation for furnishing all labor, tools, equipment, materials and incidentals necessary to complete the concrete repair work in place complete, in accordance with the plans and specifications.

END OF SECTION

## SECTION SP-8 – RESERVOIR JOINT SEAL REPLACEMENT

### 8.01. GENERAL

1. This item of work shall include the furnishing of all labor, materials, tools and equipment necessary for completing the installation of the reservoir joint sealant systems inside the circular concrete reservoir as described in this special provision and as shown on the Drawings.
  - B. This Section includes the testing and mitigation of the existing sealant material for PCB contamination, removal of the existing sealant material, preparation of the substrate and installation of the sealant system at the designated joints.

### 8.02. PERFORMANCE REQUIREMENTS

Provide and install reservoir joint sealant to tenaciously bond to the concrete surface and prevent the passage of water through the sealed joints of the structure resulting in a watertight condition.

### 8.03 SUBMITTALS

1. Product Data: Include manufacturer's written instructions for evaluating, preparing, and treating substrate, application, health and safety precautions, first aid, technical data, and tested physical and performance properties of products specified.
2. MSDS Sheets: For each product to be installed provide copies of MSDS sheets.
3. Field Testing Reports: Provide copy of required field test reports to Officer-in-Charge for documentation of completed work.
4. Hazardous Materials Inspector Certifications recognized by the State of Hawaii, of all individuals performing hazardous materials surveys – See SP-5 REMOVAL AND DISPOSAL OF BULK MATERIAL CONTAINING PCB.
5. PCB Analysis Reports: Provide copies of the field sampling, laboratory reports and analysis results of the PCB testing to the Officer-in-Charge

### 8.04. QUALITY ASSURANCE

1. Manufacturer Qualifications: Manufacturer shall have a minimum of five years of experience providing the proposed closed cell neoprene product.
2. A technical representative of the sealant manufacturer, or the material supplier with authorization from the manufacturer available during the sealant installation in order to respond to any questions or conditions requiring input from the manufacturer.
3. Field sampling of hazardous materials shall be performed by active, trained, and certified hazardous materials inspectors as observed by the State of Hawaii.
4. PCB analysis shall be performed by a Nationally Accredited Environmental Laboratory as recognized by an Environmental Laboratory Accreditation Program (ELAP).

1. DELIVERY, STORAGE, AND HANDLING

1. Deliver materials to Project site in original containers with seals unbroken, labeled with manufacturer's name, product brand name and type, date of manufacture, shelf life, and directions for storing.
2. Store materials in their original undamaged containers in a clean, dry, protected location and within the temperature range required by waterproofing manufacturer. Protect stored materials from direct sunlight.
3. Remove and replace any materials that cannot be applied within their stated shelf life.
4. Upon delivery, Contractor shall examine all materials for damage and have all damage materials removed from the site and replaced immediately.

8.06 PROJECT CONDITIONS

1. Environmental Limitations: Apply sealant in conditions and the range of ambient and substrate temperatures recommended by the manufacturer.
2. Contractor to coordinate with DOW the release of the water in the reservoir prior to the start of work.
3. Assure ventilation of reservoir and illumination is adequate for joint installation.
4. The existing wall base joint sealant is suspected of containing PCB material. Sampling, testing, and analysis for PCB of the sealant material shall be performed prior to the removal of the existing wall base joint sealant.

8.07. MATERIALS

1. Closed Cell Neoprene Sheet: Neoprene sheets installed in the floor joints of the reservoir shall conform to the minimum dimensions shown on the Drawings. The material shall be medium grade closed cell neoprene conforming to 2C3 of ASTM D 1056-00 and as further specified here in and on the Drawings.

- |   |             |
|---|-------------|
| 1. Compression deflection:                | 9-13 PSI    |
| 2. Shore 00 durometer:                    | 60-80       |
| 3. Density:                               | 8-28 PCF    |
| 4. Water absorption by weight:            | 5%          |
| 5. Temperature range:                     |             |
| 1. low (flex without cracking):           | -30° F      |
| 2. high continuous:                       | 150° F      |
| 3. high intermittent:                     | 200° F      |
| 6. Heat aging (7 days @ 158° F)           |             |
| lineal shrinkage (max.):                  | 5%          |
| 7. Tensile strength:                      | 80 PSI min. |
| 8. Elongation:                            | 150% min.   |
| 9. Resilience (bayshore-% rebound average |             |
| 1/2" thickness @ 72° F):                  | 20%-40%     |

B. Elastomeric Sealant: The material shall be designed to effectively and permanently seal joints subject to movements in concrete while immersed in water. The joint sealer shall be a two-component, non-sag, non-staining, polyurethane-based elastomeric sealant designed for potable water contact with a NSF 61 certification, which cures chemically. Acceptable sealants shall conform to ANSI/ASTM C 920 Type M, Grade NS, Class 25, or Federal Specification TT-S-00227E, Type II, Class A.

1. Products meeting these requirements are “Sikaflex–2C NS EZ Mix” by Sika Corporation ([www.usa.sika.com](http://www.usa.sika.com));
2. Other products will be considered, but must meet the product properties to be considered equal.

C. Bond Breaker: Bond breaker shall be SUPER BOND BREAKER WATER BASE as manufactured by Burke Company, San Mateo, California; SELECT EMULSION CURE 309, as distributed by Select Products Co., Costa Mesa, CA (clear or white pigmented) or approved equal. Fugitive dye may be used in bond breakers if recommended by manufacturer.

3. Joint and Crack Sealing System: The sealing system shall consist of a two-component high-modulus, high strength, moisture-tolerant, 100% solid structural adhesive epoxy and a modified flexible hypalon waterproofing tape used only where specified. Acceptable hypalon waterproofing tape products shall have tensile properties conform to ASTM D-412, tear resistance per ASTM D-624, and peel strength per ASTM D-903.

1. Products meeting these requirements are “Sikadur-Combiflex”, as manufactured by Sika Chemical Corporation, Santé Fe Springs, CA (310-941-0231) ([www.usa.sika.com](http://www.usa.sika.com));
2. Other products will be considered, but must meet the product properties to be considered equal.

#### 8.08. EXAMINATION

1. Examine substrates, areas, and conditions, with Installer present, for compliance with requirements and other conditions affecting performance.
2. Verify that concrete has cured and aged for minimum time period recommended by sealant manufacturer. Verify moisture-vapor transmission rate of less than 3 lbs. per 24 hours / 1,000 ft<sup>2</sup>, according to RMA Test Method or ASTM F1869. Contractor shall be responsible for any associated cost for this testing.
3. Proceed with installation only after unsatisfactory conditions have been corrected.

#### 8.09. REMOVAL OF EXISTING JOINT MATERIAL

1. Sampling, testing, and analysis for PCB material shall be performed prior to the removal of the existing asphalt-based joint sealant material.
2. When samples of the joint sealant material are taken, ensure that the interior floor coating already identified to be PCB-containing material does not contaminate the sampled joint sealant material.

3. The samples shall be tested and analyzed by gas chromatography using EPA method 3540C/8082A. Removal work shall not proceed until the results of the analysis are received and approved by the Officer-in-Charge. If the sample are tested positive for PCB, see the Hazardous Material Survey report in these Special Provisions, for hazardous material notices of specific materials. See these Special Provisions for requirements for removal, handling and disposal of hazardous materials.
4. Remove the existing asphalt-based joint sealant material to the depth detailed in the Drawings.
5. All traces of sealant shall be removed in locations indicated on the Drawings prior to beginning surface preparation.
6. Dispose of removed joint sealant material off site at a lawful dump site in accordance with local, state and federal laws.

#### 8.10. JOINT SURFACE PREPARATION

1. Clean and prepare vertical surface of groove wall according to sealant manufacturer's written recommendations.
2. Mask off adjoining surfaces not scheduled to receive sealant to prevent spillage.

#### 8.11. WALL BASE JOINT SEALANT APPLICATION

1. Install neoprene sheet flat on existing asphalt-based sealant left in-place in the sealant groove. Provide sheet of proper width to extend the full width of joint fitting tightly into the groove.
2. Install sealant in a continuous manner keeping the tip of the applicator immersed in the sealant in order to prevent creating air pockets in the sealant. Gently tool to top surface of the sealant approximately level at the prescribed depth of the initial sealant application.

#### 8.12. WALL BASE JOINT HYPALON STRIP INSTALLATION

1. Apply an interior stripe coating to the bottom of the reservoir wall perimeter, and a stripe coating around the tank perimeter floor as detailed on the Project Drawings. The stripe coating shall not be applied over the wall base joint sealant. Apply the interior stripe coating and terminations as described in SP-9 – PROTECTIVE COATINGS.
2. After the sealant and interior stripe coating has cured, cut to shape the Hypalon strip to be installed over the wall base joint. Contractor to take care in fitting the Hypalon strip to the curvature of the wall not to allow the sheet to bunch or gather or “fish mouth” with excess material. Install per manufacturer’s recommendations.
3. Install Hypalon strip following manufacturer’s installation directions to the properly prepared coating surfaces above and below joint. Verify Hypalon strip is continuously secured to both vertical and horizontal surfaces on each side of joint.

#### 8.13. CURING, PROTECTING, TESTING AND CLEANING

1. Allow sealant, adhesives, and stripe coating to cure according to manufacturer's written recommendations, prior to performing the reservoir wall base seal test.
2. Clean spillage on adjacent surfaces as they occur, using cleaning agents and procedures recommended by manufacturer of affected construction and related MSDS sheets.
3. Clean area of work to satisfaction of Officer-in-Charge prior to beginning of testing.
4. Wall Base Seal Testing
  1. Drill a hole at base of reservoir wall above floor surface on the interior but below bonded area of Hypalon strip installed over wall base joint. The size of the hole is to accommodate the air delivery hose used from the air compressor.
  2. Fill reservoir with between one and two feet of water.
  3. Pump compressed air under the Hypalon strip until inflated. Care is to be taken not to over inflate. Only enough air is required to allow air to escape any areas of the strip that are not air tight.
  4. Contractor to walk entire perimeter with DOW inspector and mark any areas where escaping air indicates a possible leak.
  5. Drain reservoir and dry marked areas to be repaired. Repair areas of strip that were marked to create a water tight condition.
  6. Repeat the testing procedure listed above until the entire seal strip had no escaping air when tested.
  7. After wall base seal is accepted by DOW, the hole in the reservoir wall is to be filled with repair mortar following the repair described for wall form tie plug repair in SP-7.
1. Protect installed work prior to final acceptance by DOW.
2. After the acceptance of the wall base seal, and prior to the application of the reservoir interior coating, the reservoir shall be cleaned and leak tested per Section SP-14 LEAK TESTING & DISINFECTION FOR RESERVOIR REPAIR.

#### 8.14. PAYMENT

Payment for installation of reservoir sealant joints including the PCB testing of the sealant material and wall base seal testing shall be paid as a lump sum for the offer schedule bid item it is a part. The cost shall be entered in the offer schedule item describing the work covered in this section and shall be full compensation, in place complete.

END OF SECTION

## SECTION SP-9 – PROTECTIVE COATINGS

- 9.01 **GENERAL:** Work includes the furnishing of all labor, tools, materials, and equipment required for surface preparation, waste disposal, pretreatment, coating application, touch-up, protection of uncoated surfaces, inspection, clean-up and all appurtenant work for protective coating on the interior concrete surfaces and internal piping of the reservoir. The specified coating systems shall be applied only to the surfaces and miscellaneous surfaces as noted in these specifications or shown on the Drawings. This specification modifies and supplements the painting of the interior concrete surfaces and internal piping of the reservoir as specified in “Water System Standards,” State of Hawai‘i, dated 2002, as amended.

The work shall be as follows:

1. Submit Worker Health and Safety Plan
2. Submit scaffolding plan
3. Pre-construction meeting
4. Install scaffolding
5. Remove interior coating (See SP-5 REMOVAL AND DISPOSAL OF BULK MATERIAL CONTAINING PCB)
6. Abrasive blast surfaces to be coated per manufacturer’s specifications to provide an anchor pattern suitable for coating system components
7. Test for chlorides and pH to confirm levels are within manufacturer’s acceptable levels.
8. If chlorides and pH testing results require additional cleaning, the Contractor shall steam clean the area(s) in question using steam at 275 degrees F.
9. Feather all broken edges of concrete to form a smooth transition, by grinding or other mechanical methods.
10. Vacuum concrete surface to remove dust and all loose debris.
11. Apply protective coatings as required per these specifications, and in accordance with manufacturer’s recommendations.
12. Provide full time, NACE inspection for dry film thickness, holiday detection, and adhesion testing. Contractor shall furnish all inspection equipment at the request of the Inspector as needed.
13. Remove scaffolding
14. Restore the site to its original condition, or better.

The following surfaces shall not be coated hereunder unless indicated elsewhere in the bid documents:

1. Interior ladder
2. Stainless steel items
3. Machined surfaces
4. Nameplates
5. Valve assemblies

### 9.02 RELATED WORK SPECIFIED ELSEWHERE

- A. Section SP-5      REMOVAL AND DISPOSAL OF BULK MATERIAL CONTAINING PCB
- B. Section SP-7      CONCRETE REPAIR



- C. Section SP-8 RESERVOIR JOINT SEAL REPLACEMENT
- D. Section SP-14 LEAK TESTING & DISINFECTION FOR RESERVOIR REPAIR

9.03 REFERENCES:

The publications listed below form a part of this specification to the extent referenced. The publications are referred to in the text by the basic designation only. Where a referenced document contains references to other standards, those documents are included as references under this section as if referenced directly. In case of conflict between the requirements of this specification and those of the listed documents, the requirements of this specification shall prevail.

Unless otherwise specified, references to documents shall mean the documents in effect at the time of Advertisement for Bids or Invitation to Bid. If referenced documents have been discontinued by the issuing organization, references to those documents shall mean the replacement documents issued or otherwise identified by that organization or, if there are no replacement documents, the last version of the document before it was discontinued. Where document dates are given in the following listing, references to those documents shall mean the specific document version associated with that date, regardless of whether the document has been superseded by a version with a later date, discontinued, or replaced.

1. 29 CFR – Code of Federal Regulations Title 29, Occupational Safety and Health Administration (OSHA), U.S. Department of Labor
2. 29 CFR 1910 – Occupational Safety and Health Standards
3. 29 CFR 1910.146 – Permit Required Confined Space
4. 29 CFR 1910.502 – Fall Protection Systems Criteria and Practices
5. 40 CFR – Code of Federal Regulations Title 40, Environmental Protection Agency
6. 40 CFR 50 – National Primary and Secondary Ambient Air Quality Standards
7. 40 CFR 50.12 – National Primary and Secondary Ambient Air Quality Standards for Lead
8. 40 CFR 60 – Standards of Performance for New Stationary Sources
9. 40 CFR 60.372 – Standards for Lead
10. 40 CFR 302 – Designation, Reportable Quantities, and Notification
11. ASTM – American Society for Testing and Materials International
12. ASTM D4258 – Standard Practice for Surface Cleaning Concrete for Coating
13. ASTM D4259 – Standard Practice for Abrading Concrete
14. ASTM D4262 – Standard Test Method for pH of Chemically Cleaned or Etched Concrete Surfaces

15. ASTM D4263 – Standard Test Method for Indicating Moisture in Concrete by the Plastic Sheet Method
16. ASTM D4414 – Standard Practice for Measurement of Wet Film Thickness by Notched Gages
17. ASTM D4417 – Standard Test Methods for Field Measurement of Surface Profile of Blast Cleaned Steel
18. EPA – Environmental Protection Agency
19. EPA Method 1311 – Toxicity Characteristic Leaching Procedure (TCLP)
20. EPA Method 3050 – Acid Digestion of Sediments, Sludges and Soils
21. EPA SW 846 - Test Method for Evaluating Solid Waste Physical/Chemical Methods
22. ICRI Technical Guideline No. 310.2 – Selecting and Specifying Concrete Surface Preparation for Sealers, Coatings, and Polymer Overlays (formerly No. 03732).
23. NACE – National Association of Corrosion Engineers, the Corrosion Society
24. NACE No. 2 – Near-White Metal Blast Cleaning
25. NACE No. 3/SSPC-SP6 – Joint Surface Preparation Standard: Commercial Blast Cleaning.
26. NACE No. 5/SSPC-SP12 – Joint Surface Preparation Standard: Surface Preparation and Cleaning of Metals by Waterjetting Prior to Recoating.
27. NACE No. 6/SSPC-SP13 – Joint Surface Preparation Standard: Surface Preparation of Concrete
28. NACE RPO-287 – Field Measurements of Surface Profile of Abrasive Blast Cleaned Steel Surfaces Using Replica Tape.
29. NIOSH – National Institute for Occupational Safety and Health
30. NSF – National Sanitation Foundation
31. NSF 61– Drinking Water System Components
32. SSPC – Steel Structures Painting Council, the Society for Protective Coatings
33. SSPC Guide 6 – Guide for Containing Surface Preparation Debris Generated During Paint Removal Operations
34. SSPC Guide 15 – Field Methods for Retrieval and Analysis of Soluble Salts on Steel and Other Nonporous Substrates
35. SSPC-SP1 – Solvent Cleaning

36. SSPC-SP2 – Hand Tool Cleaning
37. SSPC-SP3 – Power Tool Cleaning
38. SSPC-SP5 – White Metal Blast Cleaning
39. SSPC-SP6 – Commercial Blast Cleaning
40. SSPC-SP10 – Near-White Metal Blast Cleaning
41. SSPC-SP11 – Power Tool Cleaning to Bare Metal
42. SSPC-SP13 – Surface Preparation of Concrete
43. SSPC PA 1 – Shop, Field, and Maintenance Painting of Steel
44. SSPC PA 2 – Measurement of Dry Film Thickness with Magnetic Gauges
45. SSPC VIS 1 – Guide and Reference Photographs for Steel Surfaces Prepared by Dry Adhesive Blast Cleaning
46. SSPC VIS 3 – Guide and Reference Photographs for Steel Surfaces Prepared by Hand and Power Tool Cleaning

Whenever the Drawings or these Specifications require a higher degree of workmanship or better quality of material indicated by the above standards, then these Drawings and Specifications shall prevail.

9.04 SUBMITTALS: The Contractor shall submit the following items:

1. Technical data sheet on each product used, including ASTM test results indicating the product conforms to and is suitable for its intended use per these specifications.
2. Standard color options. The tank lining shall be white or off-white, unless otherwise directed by the Department of Water.
3. Material Safety Data Sheets (MSDS) for each product used.
4. Guidelines and recommendations for each product used including surface preparation, mixing, application, handling, storage, and cleanup. This shall include minimum time requirements for coating, recoating, and surface patches.
5. Copies of independent testing performed on the protective coating materials indicating that the protective coating materials meet the requirements as specified herein. Material test results and measurements.
6. Shop Drawings: Forced heating, dehumidification, shading, and ventilation equipment specifications as required.
7. Samples

1. Samples of each coating system shall be submitted on a 3-inch by 3-inch by 1-inch thick concrete or mortar block. Each block shall be completely coated at the specified thickness over one 3-inch by 3-inch surface with the applicable coating system. Samples shall be labeled with the coating type, application method, and dry film thickness.
2. Samples shall be provided for each batch of material to be used on the project, and shall be accompanied with certification from the manufacturer that the batches provided as samples match the batches supplied to the job site. Failure to comply may result in rejection of the finished work by the Department of Water.
3. The manufacturer's standard details for coating over joints/cracks, pipe penetrations, edge terminations, plate overlaps, and welds shall be provided.

8. Application Contractor's Qualifications:

1. Manufacturer certification that Applicator has been trained and approved in the handling, mixing, and application of the products to be used.
2. Certification that the equipment to be used for applying the products has been approved by the protective coating manufacturer and Applicator personnel have been trained and certified for proper use of the equipment.
3. Three references which verify that the coating contractor has demonstrated successful application of the specified coating systems in the past three years. Provide the site (area of coating), date of completion, the project owner's name, address and telephone number for each installation referenced.
4. Applicator must provide written documentation of having installed a minimum of 6,000 square feet (sf) of plural component spray applied protective coating the same or similar to that specified herein within the last three (3) years.
5. Proof of any necessary federal, state, or local permits or licenses necessary for the project.

9.05 QUALITY ASSURANCE:

1. The Applicator shall initiate and enforce quality control procedures consistent with applicable ASTM, NACE, and SSPC standards and the protective coating manufacturer's recommendations.
2. Protective coating products shall be standard products by recognized manufacturers who are regularly engaged in production of such materials for essentially identical service conditions and have proven reliability of at least five (5) years. If requested, the Contractor shall provide the Department of Water with the names of not less than five (5) successful applications of the proposed manufacturer's products demonstrating compliance with this requirement.
3. Materials have been specified from catalogues of manufacturers in most of the cases, to show the type and quality coatings required. Materials by other manufacturers are acceptable provided they are established as being compatible with and of equivalent quality to the coatings of the companies referenced. The Contractor shall provide satisfactory documentation from the

manufacturer of the proposed substitute material that said material meets the requirements and is equivalent to or better than the listed materials in the following properties:

1. Quality
2. Durability
3. Resistance to abrasion and physical damage
4. Life expectancy
5. Ability to recoat in future
6. Solids content by volume
7. Dry film thickness per coat
8. Compatibility with other coatings
9. Suitability for the intended service
10. Resistance to chemical attack
11. Temperature limitations in service and during application
12. Type and quality of recommended undercoats and top coats
13. Ease of application
14. Ease of repairing damaged areas
15. Stability of colors
16. Adhesion strength

Three references which verify that the submitted coating system has been used in similar environments and on similar surfaces in the past five (5) years. Provide the name, the owner's address and telephone number for each installation referenced.

The cost of all testing and analysis of the proposed substitute materials that may be required by the Inspector, shall be paid by the Contractor. If the proposed substitution requires changes in the contract work, the Contractor shall bear all costs involved and the costs of allied trades affected by the substitution.

- 4.A pre-construction meeting shall be convened three (3) weeks prior to start of coating system application. Meeting attendance is required of all parties directly affecting work of this Section, including Department of Water, General Contractor, application Contractor, Inspector and manufacturer's representative. In the meeting the following shall be discussed/reviewed:

1. Safety
5. Shutdown plan and schedule
6. Environmental requirements
7. Protection of surfaces not scheduled to be coated
8. Field quality control
9. Cleaning
10. Surface Preparation
11. Application
12. Repair of coating
13. Inspection
14. Coordination with other work
15. Required reports
16. Contractor/Inspector/Owner relationship

17. A NACE Certified Coating Inspector shall be provided by the Contractor. The Inspector will observe daily operations, procedures, and final product to ensure adherence to the specifications by Applicator.
18. The Contractor shall provide a list of three (3) potential NACE inspectors with qualifications for DOW to select one (1) to provide quality assurance on the project. All costs associated with the inspector chosen shall be borne by the Contractor.
19. The protective coating manufacturer shall provide at least two (2) days of on-site observation and site-specific recommendations relative to surface preparation, handling, application, and curing of the manufacturer's products.

#### 9.06 HEALTH AND SAFETY

- A. In confined space environments, as defined in 29 CFR 1910.146, work shall comply with the requirements set forth by OSHA applicable to the construction industry. The Contractor shall provide the require use of safety and personnel life-saving equipment for persons working in Confined Space areas, including but not limited to the following:
  1. Adequate forced ventilation, harnesses, and gas detection meter(s) that continually monitors for oxygen, hydrogen sulfide, carbon monoxide, and low explosive limit (LEL) gas levels.
  2. Fall protection shall be in accordance with 29 CFR 1926.502. All temporary ladders and scaffolding shall conform to applicable safety requirements.

3. Contractor shall provide all head and face protection equipment and respiratory devices required to safely perform this work. Equipment shall include any applicable masks recommended by the manufacturer while performing blasting or application of the coating materials.
  4. Use of ear protection devices shall be provided and required by the Contractor whenever the occupational noise exposure exceeds OSHA limits.
1. Failure to comply with health and safety laws, regulations, codes, permits, and Standard Operation Procedures will be grounds for shutting down the Work. All costs resulting from a shutdown of the Work that are due to Contractor's negligence or failure to comply with applicable safety requirements shall be borne by the Contractor. After a shutdown of the Work, the Work will not be permitted to begin again until the Inspector is satisfied that all necessary health and safety precautions are provided and implemented.
  2. Flammable or volatile solvents in coating system components constitute a hazard with regard to fire and explosions wherever flame or spark exposure is possible. All flames, smoking, and welding, etc., are strictly prohibited in work or storage areas. Fire abatement devices shall be readily available and in operating condition. Necessary precautions shall be taken to keep fire hazard to a minimum; all oily rags, waste, and other combustibles not in covered containers shall be removed from the area daily. All flammable products shall be stored in conformance with applicable State, Owner and local fire codes pertaining to flammable materials.
    1. The coating products shall never exceed the current VOC limits set by EPA and the State of Hawaii Clean Air Branch. The Contractor shall be responsible for all fines or legal costs resulting from any VOC limit violations.

#### 9.07 INSPECTION AND TESTING

3. The Contractor shall give the Department of Water and Inspector 3 days' advance notice of the start of any field surface preparation work or coating application work.
4. The Contractor shall provide a full time NACE Certified Coating Inspector at the work site anytime work is being done on this section of the project. The Inspector shall have the authority to coordinate work and make decisions pertaining to the fulfillment of this phase of the contract. The Inspector shall have a minimum of 5 years of experience in the application of the specified coatings.
5. All work relative to preparation for the application of coatings shall be conducted under the full time Inspector. The Inspector's services shall be provided and paid for by the Contractor. The Inspector shall have the authority to act on behalf of the Department of Water to reject any coating work that does not comply with these specifications or the manufacturer's written specifications.

6. Prior to the start of any work, the Contractor shall establish with the Inspector, schedules and notification procedures to ensure all surface preparation work has been inspected prior to the application of any coating. These procedures shall remain in effect for the duration of the coating project. Under no circumstances shall any surfaces be coated without prior approval of the inspector. Coatings applied without the Inspector's authorization shall be removed and reapplied at the sole expense of the Contractor.
7. The Contractor shall make the following equipment available to the Inspector upon request:
  1. Holiday testers
  20. Film thickness testers
  21. Surface preparation concrete comparators
  22. Adhesion testers

#### 9.08 APPLICATION RECORDS

The Contractor shall maintain an accurate, written record of the quantity of coating material applied and the corresponding surface area covered, a description of the area coated, the batch number, surface temperature, ambient temperature, relative humidity, dew point, and applicator on a daily basis. The Contractor shall furnish a signed copy of said record to the Inspector at the beginning of the next working day. These quantities shall be independently verified by the Inspector and reported on the Inspector's log. The Inspector shall immediately investigate and resolve any discrepancies between these reported quantities.

#### 9.09 SERVICES OF MANUFACTURER: The Contractor shall require the coating manufacturers to furnish the following services:

- A. The manufacturer's representative shall furnish at least 6 hours of on-site instruction in the proper surface preparation, use, mixing, application, and curing of the coating systems.
- B. The manufacturer's representative shall personally observe the start of surface preparation, mixing, and application of coating systems.
- C. The manufacturer's representative shall provide technical support to resolve field problems associated with the manufacturer's products furnished under this Contract or the application thereof throughout the duration of the work.
- D. The coating manufacturer shall provide written certification that the coating contractor's Supervisor and each applicator performing work on the project has been trained and approved to apply the selected coating system.

#### 9.10 WARRANTY

1. The Contractor and manufacturers shall warrant the coating system applications for a period of 3 years after final acceptance of the work. The contractor shall submit to the Department of Water a 3-year warranty bond for the total value of the complete coating system which shall cover any defects and workmanship repairs completed during the warranty period. The Contractor, at no cost to the Department of Water, shall perform all work and supply all



equipment and materials associated with the repair of failures identified in the warranty inspection.

2. The material manufacturer shall warrant, for a period of 5 years, that its products meet published physical properties and that they are free of manufacturing defects. The manufacturer shall replace any defective product.
3. The Contractor shall, within a reasonable time after receipt of written notice thereof, repair defects in materials or workmanship which may develop during the warranty period, and any damage to other work caused by such defects or the repairing of same, at his own expense and without cost to the Department of Water.
4. In the event of fault disagreement, warranty issues will be resolved through mediation involving the services of a NACE Certified Coating Inspector. Mediation and Inspection costs shall be borne by the party found to be responsible for the coating failure.

#### 9.11 COATING SYSTEM PRODUCTS:

1. Definitions: The terms "paint," "coatings," and "finishes," as used herein, shall mean surface treatments, emulsions, enamels, paints, epoxy resins, and all other protective coatings, except galvanizing or anodizing, whether used as a pretreatment, primer, intermediate coat, or finish coat.
2. Compatibility: In any coating system only compatible materials from a single manufacturer shall be used in the Work. Particular attention shall be directed to compatibility of primers and finish coats. If necessary, subject to the approval of the Inspector, a barrier coat shall be applied between existing prime coat and subsequent top coats to ensure compatibility.
3. Colors: All colors of all paint coatings shall be as indicated by the Department of Water. If colors are not indicated, then colors other than the final coat shall be selected by the Contractor. Finish colors shall be selected by the Department of Water from the manufacturer's standard color samples.

#### 9.12 PRODUCT DELIVERY AND STORAGE

1. Coating materials shall be delivered to the job site in sealed containers with weather resistant labels that clearly show the designated name, formula or specification number, batch number, color, date of manufacture, manufacturer's directions, and name of manufacturer, all of which shall be plainly legible at the time of use. Any products exceeding the manufacturer's recommended shelf life shall not be used.
2. The Contractor shall be responsible for providing temporary storage facilities to protect materials and equipment stored on-site from the elements and unauthorized personnel. The storage facility shall be capable of 24-hour climate control to maintain products within the storage temperature and humidity limits recommended by the manufacturer. The location of the storage container shall be approved in advance by the Inspector. If materials delivered to the site are used within 24 hours, the Contractor does not need to provide a storage facility as stated above.
  1. The storage facility shall be capable of containing a spill or rupture of the coating system containers within the storage facility.

1. ABRASIVES

1. The type and size of abrasive shall be selected to produce a surface profile that meets the coating manufacturer’s recommendations. All abrasives shall be new, clean, and delivered to the project site in unopened, weather resistant containers. Abrasive materials shall not be recycled for further use on this project unless approved by the Inspector.
2. All abrasives shall meet the requirements of the EPA. At no time will silica sand be allowed or used on the job site.
3. All abrasives shall be disposed of in accordance with all federal, state, and local laws at the Contractor’s expense with no cost to the Department of Water. Abrasives shall not be disposed of on-site.

1. EXISTING PRODUCTS

1. Standard Portland cement or new concrete (not quick setting high strength cement) must be well cured (minimum 28 days) prior to application of the protective coating system components.
2. Cementitious patching and repair materials must be approved prior to use as compatible with the protective coating. The manufacturer of the cementitious material shall provide information as to its suitability as a top coating with the specified protective coating. Project-specific submittals and procedures shall be provided, including application, cure time, and surface preparation procedures which permit optimum bond strength with the protective coating.
3. Remove existing coatings prior to application of the new protective coating. The Applicator shall maintain strict adherence to applicable NACE and SSPC recommendations with regard to proper surface preparation and compatibility with existing coatings.

1. COATING SYSTEMS

1. Coating: One of the following coating systems, NSF 61 certified, or an approved equal, shall be used to coat the interior surfaces of the tank:

Product:	<b>Sikagard® 7600</b>	<b>CIM 1061</b>		
Type:	Two-component Polyurethane, Bitumen Modified Waterproofing Membrane	Two-component elastomeric urethane coating		
Manufacturer:	Sika Corporation (800) 933-7452	C.I.M. Industries, Inc. (800) 543-3458		
Surface Filler:	Per Manufacturer’s recommendation	Per Manufacturer’s recommendation		

Primer:	Per Manufacturer's recommendation	Per Manufacturer's recommendation		
Topcoat:	2 coats Sikagard® 7600, @ 30 mils DFT	CIM 1061, @ 60 mils WFT		
Joint Sealant:	Per Manufacturer's recommendation	Per Manufacturer's recommendation		
Total Systems DFT:	60 mils DFT	60 mils WFT		

2. Surface preparation products for concrete: Biodegradable water-based surface cleaner shall be "Devprep 88" by Devoe or equivalent.

1. WORKMANSHIP

1. Skilled craftsman and experienced supervision shall be used on all work.

2. All coatings shall be applied under dry and dust-free conditions. Coating shall be applied in a workmanlike manner to produce an even film of uniform thickness. Edges, corners, crevices, and joints shall receive special attention to ensure that these areas are thoroughly cleaned and an adequate thickness of coating material is applied. The finished surfaces shall be free from runs, drops, ridges, waves, laps, brush marks, and variations in color, texture, and finish. The hiding shall be so complete that the addition of another coat would not increase the hiding.

9.17 PROTECTION OF SURFACES NOT TO BE COATED:

1. Remove, mask, or otherwise protect all surfaces not intended to be coated. Provide drop cloths to prevent coating materials from falling on, marring, or over spraying adjacent surfaces.
2. Surfaces not to receive protective coatings shall be protected during surface preparation, cleaning, and coating operations.

9.18 ENVIRONMENTAL CONSIDERATIONS

1. Coating Limitations: No coating work shall be performed under the following conditions:

1. Temperatures exceed the manufacturer's recommended maximum or minimum allowable.
2. Dust or smoke laden atmosphere.
3. Damp or humid conditions, where the relative humidity is above the manufacturer's maximum allowable limit.
4. Substrate or ambient temperatures are less than 5°F above the dew point. Dew point shall be measured by use of an instrument such as a Sling Psychrometer in conjunction with U.S. Department of Commerce, Weather Bureau psychrometric tables.

5. Ambient temperature that is expected to drop below 50°F or less than 5°F above the dew point within 8 hours after application of coating.
  6. Concrete surfaces contain a moisture content above that specified by the coating manufacturer.
2. Humidity Control: Desiccant or Direct Expansion Refrigeration dehumidification will be required to control the environment in the space 24 hours a day during blast cleaning, coating application and coating cure. Equipment will conform to the following requirements:
1. Equipment – Desiccant dehumidifiers will be a solid desiccant design having a single rotary desiccant wheel capable of fully automatic continuous operation. No liquid, granular, or loose lithium chloride drying systems will be accepted. The use of direct expansion (DX) refrigeration type dehumidifiers with reheat may be considered if the expected ambient temperature will remain above 60°F. Heating the space changes relative humidity only and does not change the dew point temperature. Heat alone, therefore, is not a substitute for dehumidification, unless substrate temperature is high enough to meet the dew point differential. The dehumidification system may consist of a combination of desiccant and refrigerant equipment.
  2. Air Changes – the air change rate for maintaining the required spread of 17°F between inside surface temperature and inside space dew point temperature with a maximum relative humidity of 45% in the space will depend upon the type of equipment to be used and the time of year during the application. There shall be a minimum of 2 air changes to hold the desired degree of cleanliness of the blast.

### 3. Temperature Control:

1. Auxiliary cooling or insulation maybe necessary to maintain the surface temperature at an acceptable level for the coating manufacturer’s application parameters. This auxiliary equipment must be approved for use by the supplier of the dehumidification equipment and will meet the following requirements.
    1. Refrigerant type systems must be installed in the process air supply duct and/or blended with the dehumidifier as close to the work space as possible.
    2. Only electric, indirect fired combustion, or steam coil auxiliary heaters will be used. No direct – fired space heaters will be allowed during the blasting, coating, or curing phases.
    3. The space to be controlled will be sealed off as well as possible, allowing air to escape the work space away from the point where the dehumidified air is being introduced. If it is necessary to filter the air escaping the space, the filtration system must be designed so that it does not interfere with the dehumidification equipment’s ability to control the dew point and relative humidity of the work space.
4. Atmospheric Conditions: The work and structure are located in an area that may be subject to extended periods of high humidity. The Contractor shall be expected to maintain the established production schedule despite these potentially adverse conditions by providing all labor, equipment and materials necessary to maintain a controlled environment in the area where work is to be performed. The substrate and atmospheric conditions within the controlled environment, with respect to temperature, relative humidity and dew point, shall be maintained within the limits established by the manufacturer of the selected coating system to ensure proper application and cure of the coating.

- E. Dewatering: The Contractor shall dewater and stop any active water flow into areas to be coated.

#### 9.19 SURFACE PREPARATION (CONCRETE SURFACES)

1. All surfaces to be coated and protected shall be inspected as indicated below by the Contractor prior to starting surface preparation. Contractor shall notify the Inspector in writing of any defects or discrepancies that will not allow the coating to be properly installed. Commencement of work shall be construed as acceptance of the surfaces and it shall be the responsibility of the Contractor to correct any defect appearing in the surfaces once the coating preparation work has begun.
2. Concrete repair materials shall be compatible with the specified coating system and shall be thoroughly cured per the coating manufacturer's recommendations prior to the start of installation.
3. The Contractor shall comply with the applicable EPA and State of Hawaii Clean Air Branch regulations for blast cleaning.
4. Abrasive blasting shall be performed only by skilled personnel utilizing appropriate equipment. A pattern shall be followed by the blaster to ensure a uniform surface, free of contaminants and having an open pore structure is produced.
5. Abrasive blasting, water jetting and coating application hoses shall be grounded to prevent accumulation of static electricity.
6. Compressed air for air blast cleaning shall be supplied at adequate pressure from compressors equipped with oil/moisture separators that remove at least 95% of the contaminants. The performance of the oil/moisture separators will be subject to blotter tests for conformance.
7. Surface Preparation shall be as follows:
  1. All degraded concrete and loose mortar shall be removed in accordance with SSPC SP2 and SP3.
  2. The Contractor shall test the surfaces for soluble salts with the use of Chlor\*Test as manufactured by Chlor\*Rid International or approved equivalent. The interior surfaces of the tank shall have a maximum concentration of 5 micrograms per square centimeter ( $\mu\text{g}/\text{cm}^2$ ). A test shall be conducted for every 500 square feet ( $\text{ft}^2$ ) of surface area to be coated at locations determined by the Inspector.
  3. If the soluble salt test indicates chloride concentrations greater than the limit outlined in these Specifications, the Contractor shall use Chlor\*Rid, as manufactured by Chlor\*Rid International or approved equal, in the water source during water cleaning to remove the salts from the substrate. A substrate's surface preparation will be accepted once the soluble salt concentration is below the limit listed in these Specifications.
  4. If there are no soluble salts on the surfaces after removal of the existing coating and damaged concrete, the surfaces shall be cleaned with a detergent in accordance with

ASTM D4258. Detergent residue shall be thoroughly removed from the concrete surface with clean water.

5. Abrasive blast cleaning shall be performed using dry abrasive blasting procedures in accordance with ASTM D4259 and SSPC SP 13/NACE No. 6. Abrasive particle size and type shall be sufficient to produce a surface profile conforming to the manufacturer's recommendations for each coating product. Abrasive material in the blast cleaning operation shall be free of contaminants that would interfere with adhesion of the coatings and shall not be reused.
6. The blast pattern shall be by systematic removal from a defined rectangular area. Evidence of random blast patterns or contaminants will result in rejection of the surface and the blasting will be repeated until a suitable surface is obtained. The texture of the concrete surface after blasting shall be similar to that of coarse sandpaper. Any sharp, protruding edges shall be rounded or trimmed by chipping, peening, brushing or other approved methods.
7. During abrasive blast cleaning, prevent damage to adjacent coatings or structures. Blast cleaning and coating shall be scheduled such that dust, dirt, blast, particles, old coatings, or other contaminants, will not damage or fall upon uncured coatings.
8. After abrasive blasting, surfaces shall be cleaned by vacuum, or washed with clean water to remove dust, salts and detergent residue.
9. The finished surface shall consist of sound concrete with exposed aggregate. The Contractor shall not remove more material than necessary from the concrete surface in order to meet these requirements.
10. Concrete surfaces to be coated shall have an even color, gray or gray-white. The surface shall not have pockets, holes, or sharp changes of surface elevation. Scrubbing with a stiff bristle-fiber brush shall produce no dusting or dislodging of cement or sand. Sprinkling water on the surface shall produce no water beads or standing droplets.
11. In accordance with ASTM D4262, test to determine the pH of the concrete surface after the surface has been thoroughly cleaned and washed. If the pH is outside the range recommended by the coating manufacturer, then the surface must be neutralized by removing concrete until the surface pH of 7 or greater is obtained prior to any coating application. One pH test shall be performed every 500 square feet, or less, and at locations determined by the Inspector.
12. The Contractor shall test for capillary moisture in accordance with ASTM D4263. Moisture tests shall be taken every 500 square feet or less and at locations determined by the Inspector. If capillary moisture is present, the coating manufacturer shall be consulted to determine primer requirements and special coating application criteria.
13. All abrasive blasting material and debris generated by the cleaning procedure shall be removed from the site to an appropriate disposal facility at the Contractor's expense.
14. In the event that questions arise concerning the quality of the blast cleaning, the Inspector shall be the sole judge as to whether the level of cleanliness conforms to the standard and specifications.

15. The Contractor shall keep the work area in a clean condition and shall not permit materials to accumulate as to constitute a nuisance or hazard to the work performance or the operation of the existing facilities.
16. Concrete surfaces requiring spot repair shall be rehabilitated following surface cleaning and abrasive blasting. After the applied concrete repair materials have cured per the manufacturer's recommendations, they shall be swept blasted to remove surface residuals and establish an anchor profile equivalent to coarse sandpaper prior to coating application.
17. All prepared surfaces shall be observed and approved by the Inspector prior to subsequent work.

#### 9.20 SURFACE PREPARATION (STEEL SURFACES)

1. All hand tools used for grinding and sanding on or near lead containing paint shall be equipped with High Efficiency Particulate Air (HEPA) filters designed to containing paint chips.
2. Surface preparation shall be performed as follows:
  1. Remove all existing debris, dirt, and deteriorated coating by Low Pressure Water Cleaning per SSPC SP 12/NACE No. 5. The minimum pressure of the Water Cleaning shall be 5,000 psi.
  2. The Contractor shall test the surfaces for soluble salts with the use of Chlor\*Test as manufactured by Chlor\*Rid International or approved equivalent. The steel surfaces within the tank shall have a concentration of 0 micrograms per square centimeter ( $\mu\text{g}/\text{cm}^2$ ). A test shall be conducted for every 500 square feet ( $\text{ft}^2$ ) of steel surface area to be coated at locations determined by the Inspector.
  3. If the soluble salt test indicates chloride concentrations greater than those outlined in these Specifications, the Contractor shall use Chlor\*Rid, as manufactured by Chlor\*Rid International or approved equal, in the water source during water cleaning to remove the salts from the steel surfaces. A substrate's surface preparation will be accepted once the soluble salt concentration is as outlined in these Specifications.
  4. All oil, grease, welding fluxes and other surface contaminants shall be removed by solvent cleaning per SSPC SP1 prior to abrasive blasting.
  5. The Contractor shall abrasive blast the surfaces to be coated according to SSPC SP10 and these Specifications.
6. For abrasive blast cleaning, the type and size of abrasive shall be selected to produce a surface profile that meets the coating manufacturer's recommendation for the particular coating and service conditions. Abrasives for submerged and severe service coating systems shall be clean, hard, sharp cutting crushed slag.
  1. The abrasive shall not be reused unless otherwise approved by the Inspector. For automated shop blasting systems, clean oil-free abrasives shall be maintained.

2. The Contractor shall comply with the applicable federal, state, and regional air pollution control regulations for abrasive blast cleaning.
1. Compressed air for air blast cleaning shall be supplied at adequate pressure from well-maintained compressors equipped with oil/moisture separators which remove at least 95% of the contaminants.
4. Abrasive blasted cleaned surfaces shall match the standard samples shown in SSPC VIS 1 or VIS 3 for each product's recommended profile.

#### 9.21 MIXING, AND THINNING OF MATERIALS

Unless otherwise specified herein, the coating manufacturer's printed recommendations and instructions for thinning, mixing, and handling coating materials shall be strictly observed. Prepare multiple component coatings using all of the contents of the container for each component packaged by the manufacturer. Do not use partial batches. Do not use multiple component products that have exceeded their shelf life. Provide 4 touch-up kits for small area work. Mix only the components specified and furnished by the manufacturer. Do not add additional components for color.

#### 9.22 APPLICATION (CONCRETE AND STEEL)

1. The application of coating shall be performed in two phases.
  1. Phase 1: The application of stripe coating at the base of the reservoir wall and perimeter of the floor slab to facilitate the replacement of the wall base joint seal per SP-8 RESERVOIR JOINT SEAL REPLACEMENT.
  2. Phase 2: Fully coat the interior of the reservoir as required by the plans and specifications, following a successful reservoir leak test, and prior to performing the reservoir disinfection per SP-14 LEAK TESTING & DISINFECTION FOR RESERVOIR REPAIR.
3. All coating applications shall conform to applicable standards of the OSHA, SSPC, NACE, ASTM, and the manufacturer's printed instructions. Material applied prior to approval of the surface preparation by the Inspector shall be removed and reapplied to the satisfaction of the Inspector at the expense of the Contractor.
4. The Contractor's coating equipment shall be designated for application of the materials specified and shall be maintained in first class working condition. Compressors shall have suitable traps and filters to remove water and oils from the air. The Contractor's equipment shall be subject to approval of the Inspector. All gasoline or diesel powered equipment shall be parked over a lined containment area to minimize environmental impacts due to leaks or spills.
5. Coating application shall be as follows:
  1. Remove dust, blast particles, and other debris from blast cleaned or previously coated surfaces by dusting, sweeping, washing, or vacuuming. Allow ventilator fans to clean airborne dust to provide good visibility of working area prior to coating applications.



2. Apply the first coating application within 24 hours after blast cleaning and before any water, dirt, or foreign matter has accumulated on the surface.
  3. Keep coating materials at a uniform consistency during application (stir and drain as necessary). Apply each coating evenly, at the specified film thickness, to achieve a finish free of pinholes, drops, brush marks, ridges, waves, sags, runs, and other evidence of poor workmanship. Edges, corners, crevices, and joints shall receive special attention to ensure thorough surface preparation and adequate thickness of coating material are provided.
  4. Stripe coat all steel edges, corners, joints and other protrusions. Finished surfaces shall be free from defects, pinholes, holidays or blemishes. Care shall be exercised to prevent coatings from being spattered onto surfaces that are not to be coated.
  5. The coating thickness shall be measured at the time of application using a wet film thickness gauge approved and in accordance with ASTM D4414.
  6. If minimum/maximum recoat times are not stated in the coating manufacturer's standard product literature, then the Contractor must supply such information to the Inspector for approval, prior to the start of the coating application; or supply a written statement from the coating manufacturer that limitations for recoat times do not apply to the coating specified on the project.
  7. When overlapping transitions between sections of coating applied on different days, abrasive blast or mechanically abrade an 18-inch-wide strip of the previously applied coating, measured from the leading edge, to remove all gloss. Vacuum prior to application of fresh topcoat material feathered at least 12 inches into the abraded area. Avoid application onto glossy or untreated areas of the previously installed coating.
  8. The finished coating application shall be protected from damage during curing and shall be cured as recommended by the manufacturer, prior to returning the reservoir to service.
  9. All concrete coating edges, adjacent to pipe penetrations, vents, access hatches and other coating termination locations shall be terminated by keying into the concrete with a 1/4-inch-wide by 3/8-inch deep saw cut. Prior to coating application, the saw cut shall be dried and vacuumed to remove all dust and residue. During coating application, a liberal amount of material shall be applied to the saw cut area, then pressed with a trowel or putty knife into the saw cut cavity and smoothed level to the adjacent surfaces.
6. The coating manufacturer's standard details, submitted by the Contractor to the Department of Water, shall be used for coating applications over construction and expansion joints.

### 9.23 CURING OF COATING

- A. The Contractor shall provide curing conditions in accordance with the conditions recommended by the coating material manufacturer or by this Section, whichever is the highest requirement, prior to placing the completed coating system into service.
- B. Dehumidification and temperature control in enclosed areas may be required during abrasive blasting and curing of coatings.

## 9.24 TESTING AND INSPECTION

- A. Surfaces prepared as described in this Specification and per the manufacturer's recommendations shall be observed by the Inspector prior to applications of coatings to verify compliance.
- B. Scaffolding or ladders to facilitate inspection shall be erected and moved to locations where requested by the Inspector.
- C. Whenever required by the Inspector, the Contractor shall provide additional illumination and ventilation required for inspections. Adequate illumination shall consist of explosion-proof lights and electrical equipment required to meet safety standards. The Inspector shall determine the level of illumination for inspection purposes.
- D. The inspection devices listed below, or approved equivalents, shall be provided by the Contractor to the Inspector as required in good working condition and with calibration data prior to beginning any Work. These items shall remain available until final acceptance of the coating applications per the parameters listed below:
  - 1. Film Thickness Testing: The dry film coating thickness shall be measured in accordance with the SSPC "Paint Application Specification No. 2".
    - a. Wet film gauge: approved by ASTM D4414 (concrete)
    - b. Dry film gauge: PosiTector 100C or other approved by ASTM D6132 (steel)
  - 2. Psychrometer: Sling, mechanized or digital.
  - 3. Surface Temperature: Infrared surface temperature gauge.
  - 4. Coating Adhesion Testing: Adhesion tests shall be performed according to ASTM D4541 for Type II instruments. The Department of Water believes the following manufacturers are capable of producing equipment and/or products that will satisfy the requirements of this Section. This statement, however, shall not be construed as an endorsement of a particular manufacturer's products, nor shall it be construed that named manufacturers' standard equipment or products will comply with the requirements of this section. Candidate manufacturers include Elcometer Model 106, or equal.
  - 5. Coating Thickness Testing: During installation, all coating applications shall be inspected prior to each succeeding application. The procedure for collecting representative thickness data shall be as follows:
    - a. No measurements shall be made until at least 8 hours after application of the coating or as otherwise approved by the Inspector.
    - b. On concrete, the coating thicknesses shall be measured at the time of application using a wet film gauge.
    - c. Inspector shall determine where and how often to test for film thicknesses, and as a minimum, the requirements of SSPC PA 2 will be followed.
    - d. Discard any unusually high or low gauge reading that cannot be repeated consistently. Take the average (mean) of the three gauge readings as the spot measurement. The average spot measurement shall meet or exceed the specified dry film thickness for each application.

6. Adhesion Testing on Concrete:
  - a. Adhesion tests shall be performed according to ASTM D4541 for Type II instruments for every 500 sq. ft. of coating material applied.
  - b. A minimum of three 20mm diameter dollies shall be affixed to the coated surface. Each testing location shall be identified and recorded by the Inspector. The adhesive used to attach the dollies to the liner shall be rapid setting with a tensile strength in excess of the liner material and permitted to cure in accordance with the manufacturer recommendations.
  - c. The lining material and dollies shall be adequately prepared to receive the adhesive. Failure of the dolly adhesive shall require retesting.
  - d. Two of the three adhesion pulls shall exceed 200 psi or concrete failure with more than 50% of the subsurface adhered to the coating, unless otherwise specified in the Special Provisions.
  - e. If one of the three dollies fails, an additional location shall be tested in the same structure. If two of the four dollies tested fail, the liner shall be removed and replaced at the Contractor's expense.
  - f. The Inspector shall record the type of adhesive used, the length of time allowed to cure, and the type of failure observed on the dolly.

#### 7. Final Inspection

1. At the completion of all coating work, a final inspection shall be conducted. The Contractor, a coating manufacturer representative, the Inspector, and the Department of Water shall jointly conduct a final inspection to establish that all work is complete per the Contract Documents.
2. Any deficiencies found shall be documented and corrected before granting final work acceptance.
3. The Contractor shall use video and still photography to thoroughly document each work area condition during the final inspection. A copy of all photographs and video shall be provided to the Department of Water, and the Contractor shall keep the originals on file. The photographs and video shall be the basis for condition evaluation of the coating systems at the warranty inspection.
4. Inspection costs in excess of one re-inspection or cancellation of the coating work shall be borne by the Contractor.

#### 9.25 WARRANTY INSPECTION

- A. Warranty inspections shall be conducted within the last warranty year following work acceptance. All coating applications found deficient or defective during the warranty period shall be repaired or replaced by the Contractor, to the satisfaction of the Department of Water. These repairs or replacements shall be in accordance with this Specification and the material manufacturer's recommendations at no cost to the Department of Water.
- B. Deficient or defective areas in the coatings include blisters, peeling, disbondment or cracking. The final inspection shall be used to assist in determining deficient or defective areas in the coating systems.

- C. The Department of Water shall establish a date for the inspection and provide 30 days' advance notification to the Contractor, so the Contractor and a coating manufacturer representative can be present during the inspection.
- D. The cost of the warranty inspection shall be borne by each party. The Contractor shall arrange for the presence of the coating manufacturer and bear all associated costs. Inspection costs in excess of one re-inspection or cancellation not attributed to the Department of Water shall be borne by the Contractor. The Contractor shall arrange for the cover all costs for repair work under the warranty.
- E. If the warranty inspection is not held during, or before, 1 month prior to the end of the warranty period, the Contractor is not relieved of its warranty responsibilities under the contract documents. If the contractor fails to conduct the last-warranty-year inspection for reasons not attributed to the Department of Water, the warranty period shall be extended until the inspection is conducted and defective work is repaired.

#### 9.26 REPAIRS

- A. Coating damage due to adhesion testing or if areas found to have an improper finish, insufficient film thickness or other deficiencies; then the Contractor shall clean, prepare and topcoat the coating surface per the manufacturer's recommendations to obtain the specified finish and coverage. Work shall be free of runs, bridges, shiners, laps, or other imperfections.
- B. Damaged or defective coating shall be removed by the Contractor and the surface prepared in accordance with these Specifications before recoating.

#### 9.27 CLEANUP

- A. Upon completion of the work, all staging, scaffolding, containers and work related material or debris shall be removed from the site to the satisfaction of the Inspector and Department of Water.
- B. Coating overspray and oil spots or stains on all surrounding surfaces shall be removed and the job site cleaned.
- C. All Damage to surfaces resulting from the Contractor's work shall be cleaned, repaired or refinished, to the satisfaction of the Inspector at no cost to the Department of Water.
- D. Disposal of spent solvents, thinners, coating components and other related materials shall be the Contractor's responsibility and shall meet all federal, state, and regional regulations for safe disposal.

- 9.28 PAYMENT: Payment for protective coatings shall be made at the respective Lump Sum Bids as specified in the offer schedule. Payment shall represent full compensation for furnishing all labor, tools, equipment, material and incidentals necessary to complete the protective coatings in place complete, in accordance with the plans and specifications.

END OF SECTION

## SECTION SP-10 – LIQUID-APPLIED ROOFING SYSTEM

10.01 GENERAL DESCRIPTION: This item of work shall include the furnishing of all labor, materials, tools and equipment necessary for the complete installation of fully reinforced cold fluid-applied polymethyl methacrylate liquid resin roofing membrane and membrane flashing system where indicated on the drawings.

### 10.02 SECTION INCLUDES:

1. Adhered cold liquid-applied reinforced waterproofing system including, membrane, penetration flashings, base flashings, expansion joints, and non-skid finish.
2. Substrate preparation, cleaning, after leveling and patching.
3. Waterproofing membrane installation.
  - D. Flashing installation and expansion joint installation.

### 10.03 REFERENCES

1. American Society for Testing and Materials (ASTM) ASTM C 836 Standard Specification for High Solids Content, Cold Liquid-Applied Elastomeric Waterproofing Membrane
2. National Roofing Contractors Association (NRCA) Roofing and Waterproofing Manual
3. American Concrete Institute (ACI) ACI-308 - Recommended Practice for Curing Concrete
4. ASTM - D638 - Test Methods for Tensile Properties of Plastics
5. ASTM - D4258 - Standard Practice for Surface Cleaning Concrete for Coatings
6. ASTM - D4259 - Standard Practice for Abrading Concrete
7. ASTM - D4541 - Method for Pull-Off Strength of Coatings using Portable Adhesion Tester
8. ASTM - E96(A) - Test Methods of Moisture Transmission of Material
9. ASTM E-108, ANSI/UL 790 for fire resistance
10. Steel Structures Painting Council (SSPC)
11. International Concrete Repair Institute (ICRI)

### 10.04 SUBMITTALS FOR REVIEW:

- A. Roofing System Product Data: Provide current standard printed product literature indicating characteristics of membrane materials, flashing materials, components, and accessories, product specification, and installation.

1. Product Samples: Submit product samples of membrane and flashing materials showing color, texture, thickness and surfacing representative of the proposed system for review and approval by Officer-in-Charge.
2. Submit sample copies of both the Manufacturer and Applicator warranties for the periods stipulated. Each specimen must be a preprinted representative sample of the issuing company's standard warranty for the system specified.
3. Submit copies of current Material Safety Data Sheets (MSDS) for all components of the work.
4. Submit documentation from the roofing system manufacturer to verify contractor's status as an approved applicator for warranted installations.
5. Roofing System Shop Drawings: Submit shop drawings of cold liquid-applied reinforced unsaturated polyester showing a project plan, size, flashing details, and attachment for review and approval by the Officer-in-Charge and roofing system manufacturer.
6. Provide certificates for the following;
  1. Roofing System Manufacturer: Manufacturer has been manufacturing product specified for the past 20-Years.
  2. Roofing Contractor: Provide list of projects, including address, contact information, type of products installed and square footage.

10.05 QUALITY ASSURANCE:

- A. Roofing System Manufacturer: Company specializing in manufacturing the products specified in this section with ten (10) years documented experience. Submit the following certificate when making a substitution request, The roofing system manufacturer has been manufacturing proposed product for the past 10-Years.
  - B. Applicator: Company specifically trained in performing the work of this section with (3) years documented experience and approved by system manufacturer for warranted membrane installation. Applicator shall submit the following certification for review:
    1. Applicator shall submit documentation from the roofing system manufacturer to verify contractor's status as an approved applicator for warranted installations.
1. Calculate moisture content of substrate materials. Contractor shall determine substrate moisture content through-out the work and record with Daily Inspection Reports or other form of reporting acceptable to the Officer-in-Charge or designated representative, and roofing system manufacturer representative.
  2. Random tests to determine tensile bond strength of membrane to substrate shall be conducted by the Contractor at the job site using an Elcometer Adhesion Tester Model 106 or similar device, or by the performance of a manual pull test. Contractor shall perform tests at the beginning of the Work, and at intervals as required to assure specified adhesion with a minimum of three (3) tests per 5000 square feet. Smaller areas shall receive a minimum of three (3) tests. Test results shall be submitted to the Officer-in-Charge and the roofing system manufacturer representative. Contractor shall immediately notify the Officer-in-

Charge and roofing system manufacturer in the event tensile bond test results are below specified values.

1. Adequate surface preparation will be indicated by tensile bond strength of membrane to substrate greater than or equal to 116 psi.
2. Adequate surface preparation will be indicated by 135° peel bond strength of membrane to substrate such that cohesive failure of substrate or membrane occurs before adhesive failure of membrane / substrate interface.
3. In the event the tensile bond strengths are lower than the minimum specified, additional substrate preparation is required. Repeat testing to verify suitability of substrate preparation.

#### 10.06 QUALITIES MONITORING:

Contractor to monitor quantities of installed materials such as application of resin mixture, reinforcing fleece and flashing. Perform Work in accordance with manufacturer's instructions.

#### 10.07 MOCK-UPS:

Mock-up areas shall be used to determine required methods and tools to obtain degree of substrate preparation required by the roofing system manufacturer. Conduct tests as required above to verify that substrate preparation meets specified requirements. Tests shall include, but are not limited to, tensile bond strength and moisture content of substrate.

1. Prepare and clean a three (3) foot by three (3) foot area of each substrate material type.
2. Submit findings in writing to Officer-in-Charge and roofing system manufacturer.
3. Mock-up areas shall be maintained for quality control for the entire project.

#### 10.08 REGULATORY REQUIREMENTS:

- A. Conform to applicable building and jurisdictional codes for roofing/waterproofing assembly and fire resistance requirements.
- B. Comply with requirements of OSHA, NIOSH or local governing authority for work place safety.

10.09 PRE-INSTALLATION MEETING: Convene a pre-installation meeting at the job site one (1) week before starting work of this section. Require attendance of parties directly affecting work of this section, including but not limited to, Officer-in-Charge, Roofing Contractor, and Roofing system Manufacturer's Representative. Review roofing/waterproofing preparation and installation procedures, mock-up installation location, coordination and scheduling required with related work, and condition and structural loading limitations of deck/substrate.

#### 10.10 DELIVERY, STORAGE, AND PROTECTION:

- A. The Contractor, together with the Officer-in-Charge, shall define a storage area for all components. The area shall be cool, dry, out of direct sunlight, and in accordance with

manufacturer's recommendations and relevant regulatory agencies. Materials shall not be stored in quantities that will exceed design loads, damage substrate materials, or hinder installation or drainage.

- B. Store solvent-bearing solutions, resins, additives, inhibitors or adhesives in accordance with the MSDS and/or local fire authority. After partial use of materials replace lids promptly and tightly to prevent contamination.
- C. Roll goods shall be stored horizontally on platforms sufficiently elevated to prevent contact with water and other contaminants. DO NOT use rolls which are wet, dirty or have damaged ends.
- D. Roofing materials must be kept dry at all times. If stored outside, raise materials above ground or roof level on pallets and cover with a tarpaulin or other waterproof material. Plastic wrapping installed at the factory should not be used as outside storage covers.
- E. Follow manufacturer's directions for protection of materials prior to and during installation. Do not use materials which have been damaged to the point that they will not perform as specified. Fleece reinforcing materials must be clean, dry and free of all contaminants.
- F. Copies of all current MSDS for all components shall be kept on site. Provide any and all crew members with appropriate safety data information and training as it relates to the specific chemical compound he or she may be expected to deal with. Each crew member shall be fully aware of first-aid measures to be undertaken in case of incidents. Comply with requirements of OSHA, NIOSH or local governing authority for work place safety.

#### 10.11 ENVIRONMENTAL REQUIREMENTS:

- A. Do not apply roofing membrane during or with the threat of inclement weather.
- B. Application of cold liquid-applied reinforced unsaturated polyester roofing membrane may proceed while air temperature is lower than 95°F providing the substrate is a minimum of 5°F above the dew point.
- C. Ensure that substrate materials are dry and free of contaminants. DO NOT commence with the application unless substrate conditions are suitable. Contractor shall demonstrate that substrate conditions are suitable for the application of the materials, including the vapor drive pressure at the time of installation.
  - 1. If the Contractor believes dropping the water level of the reservoir at the time of the installation will aid in reducing the vapor drive pressure, the Contractor is to make their request to the Officer-In-Charge to verify if the reservoir water level can allow the water level to be dropped and coordinate the lowering of the reservoir water level, if it is acceptable to Board of Water Supply Water System Operations.

#### 10.12 COORDINATION & PROTECTION:

- A. Coordinate the work with the installation of associated metal flashings, accessories, appurtenances, etc. as the work of this section proceeds.



- B. Building components shall be protected adequately (with tarp or other suitable material) from soil, stains, or spills at all hoisting points and areas of application. Contractor shall be responsible for preventing damage from any operation under its Contract. Any such damage shall be repaired at Contractor's expense to DOW satisfaction or be restored to original condition.
- C. Provide barricades, retaining ropes, safety elements (active/passive) and any appropriate signage required by OSHA, NIOSH, and NSC and/or the Officer-in-Charge.
- D. Protect finished roofing membrane from damage by other trades. Do not allow waste products containing petroleum, grease, acid, solvents, vegetable or mineral oil, animal oil, animal fat, etc. or come into direct contact with the membrane.

10.13 WARRANTY:

- A. Manufacturer's Premier Warranty: Provide (20) year manufacturer's premier warranty under provisions of this section. This warranty provides for cost of labor and materials for loss of water tightness, limited to amounts necessary to effect repairs necessitated by either defective material or defects in related installation workmanship, with no dollar limitation ("NDL").
- B. Waterproofing Contractor's Warranty: Provide 2 year "Applicator Maintenance Warranty" covering workmanship for all work of this section including installation of membrane, flashings, metal work, and waterproofing accessories.
- C. Submit (2) executed copies of both the manufacturer and applicator warranties for the periods stipulated, starting from the date of substantial completion. Each warranty must be signed by an authorized representative of the issuing company.

10.14 PRODUCTS:

- A. General: The products herein specified are totally pre-engineered products of the listed manufacturer and establish criteria for the approval of substitutions. Products must be part of a pre-engineered, reinforced liquid-applied roofing system, equivalent in function, quality, composition and method of application to be considered for approval as an "Approved Substitute".
- B. Roofing System: Cold fluid-applied reinforced polymethyl methacrylate waterproofing membrane. Products manufactured and supplied by the following:
  - 1. Kemper System's "Kemperol AC" is a two-component, rapid curing PMMA-based waterproofing system.
  - 2. Soprema "Alsan RS" PMMA Liquid Applied Solutions, 310 Quadral Drive, Wadsworth, OH 44281; Tel: 800-356-3521; Tel: 330-334-0066; Website: www.soprema.us.
  - 3. Approved equal

- C. Membrane Flashings: A composite of the same resin material as field membrane with fleece reinforcement; colored aggregate topcoat surfacing or aliphatic polyester polyurethane coating to match field membrane.
- D. Accessories:
1. PMMA Primer: Polymethyl methacrylate liquid resin for use in improving adhesion of membrane to wood, metal, and cementitious/masonry substrate surfaces, as provided by the following manufacturer:
    1. Kemper System's Kempertec AC primer.
    2. Soprema Alsan RS 276 Primer
    3. Approved equal
  2. Anti-Skid Aggregate Surfacing Finish Coating Resin: Two-component methyl methacrylate-based coating suitable for use to both bond and seal aggregate, as provided by the following Manufacturer:
    1. Kemper System, Inc.'s Kemperdur AC Finish.
    2. Soprema Alsan RS Surfacing Aggregate
    3. Approved equal
  3. Color Coating: Two-component methyl methacrylate-based coating suitable for use as a colored coating, as provided by the following Manufacturer:
    1. Kemper System, Inc.'s Kemperdur AC Finish.
    2. Soprema Alsan RS Colored Quartz
    3. Approved equal
  4. Tools, Accessories, and Cleaners: Supplied and/or approved by roofing system manufacturer for product installation.
  5. Topcoat Surfacing Aggregate: Kiln-dried Surfacing Silica Sand shall be washed, kiln-dried, and dust-free with a size specification of 16 Grit for the entire surface.
  6. Leveling and Patching Aggregate: Silica sand shall be washed, kiln-dried, and dust-free, suitable for troweling or pourable self-leveling, round grain or angular with the following size specification:
    1. For voids less than 1/4" in depth: 20 Grit
    2. For voids 1/4" to 2" in depth: 20 Grit
    3. Mixing Proportions shall be a ratio of resin to sand at 1:2 by volume for leveling, 1:4 by volume for patching, volume or as approved by roofing system manufacturer.
  7. Backer Rod: Expanded, closed-cell polyethylene foam designed for use with cold-applied joint sealant.
  8. Miscellaneous Fasteners: Appropriate for purpose intended and approved by roofing system manufacturer; length required for thickness of material; as supplied by roofing system manufacturer.

9. Caulking: Single component, non-sag elastomeric polyurethane sealant, as recommended or supplied by roofing system manufacturer for use in making airtight and watertight seals where required.
10. Temporary and Night Sealant: As recommended or required by roofing system manufacturer.

#### 10.15 EXECUTION

##### A. Examination:

1. Verify that surfaces and site conditions are ready to receive work.
2. Verify deck/substrate openings, curbs, and protrusions through deck/substrate, and reglets are in place and solidly set.
3. Verify deck/substrate is structurally supported, secure and sound.

##### B. Preparation of Substrate:

1. General: Surfaces to be prepared as a substrate for the new waterproofing system as follows:
  1. The contractor shall determine the condition of the existing structural deck/substrate. All defects in the deck or substrate shall be corrected before new waterproofing work commences. Areas of deteriorated deck/substrate, porous or other affected materials must be removed and replaced with new to match existing.
  2. Existing slab joints shall be prepared and covered as recommended by manufacturer prior to installation of roofing system.
  3. Prepare flashing substrates as required for application of roofing system flashings.
  4. Inspect substrates, and correct defects before application of roofing system. Fill all surface voids greater than 1/16 inch wide and/or deep with an acceptable fill material.
  5. Remove all ponded water, from the work substrate prior to installing roofing system materials.
  6. The final substrate for roofing system shall be clean, dry, free of loose, spalled or weak material including coatings, mineral aggregate, and flood coat/gravel surfacing, oil, grease, contaminants, abrupt changes in level, waterproofing agents, curing compounds, and free of projections which could damage membrane materials.
2. Concrete:
  1. Concrete shall be free of oil, grease, curing compounds, loose particles, moss, algae growth, laitance, friable matter, dirt, bituminous products and previous waterproofing materials.
  2. Concrete shall be dry with a maximum moisture content of five (5) percent. Determinations of moisture content shall be performed by the Contractor. Contractor shall be responsible to perform periodic evaluations of moisture content

during the work. Moisture evaluation results shall be submitted in writing to the Officer-in-Charge and the roofing system manufacturer representative.

3. Where required, concrete shall be abrasively cleaned in accordance with ASTM D4259 to provide a sound substrate free from laitance with an open concrete surface. When using mechanical methods to remove existing waterproofing products or surface deterioration, the surface profile is not to exceed 1/8 inch (peak to valley).
  4. The substrate shall be sound and all spalls, voids and blow holes on vertical or horizontal surfaces must be repaired prior to placement of the primer coat. Spalls and other deterioration shall be repaired in accordance with the requirements of Section 30.1 Concrete Repair of the Special Provisions.
  5. Areas of minor surface deterioration of 0.50-inch or greater in depth shall be repaired in accordance with the requirements of Section 30.1 Concrete Repair to prevent possible ponding of the system, leading to excessive usage of primer and resin.
  6. Extent and location of thin surface patching shall require approval of the Officer-in-Charge and roofing system manufacturer representative prior to the application of any system component.
3. Steel/Metal:
1. Clean and prepare metal surfaces to near white metal in accordance with SSPC - SP3 (power tool clean) or as required by roofing system manufacturer. Extend preparation a minimum of three (3) inches beyond the termination of the membrane flashing materials. Notch steel surfaces to provide a rust-stop.
  2. Stainless steel (series 400, 300) shall be abraded to provide a rough open surface.
4. Other Surfaces: Remove all contaminants as required by roofing system manufacturer. Surface preparation shall be performed by means approved by Officer-in-Charge.
5. Finish Leveling, Patching and Crack Preparation:
- a. General: polymethyl methacrylate primer/sand mix is the preferred material for all substrate finish leveling, crack and wall/deck preparation and patching. Resin/sand patching mix provides a fast-set time of approximately 12 hours and does not require surface grinding.
  - b. Substrate Leveling & Patching: The work described in the subsection is in addition and unrelated to the filling of low spots in the roof as specified in Section 30.1. Substrate conditions are to be evaluated by the Contractor, Officer-in-Charge, and roofing system manufacturer. Perform leveling and patching operations as follows:
    1. Level uneven surfaces with a leveling mixture of unsaturated polyester resin/primer and approved kiln-dried silica sand in a 1:2 primer to sand ratio by volume. Spread and plane this compound with a squeegee and trowel to achieve a flat surface.
    2. Fill cavities with a patching mixture of primer and approved kiln-dried sand in a 1:4 primer to sand ratio by volume.
    3. Silica sand must be kept absolutely dry during storage and handling.
    4. Any surface to be leveled or filled must first be primed with an appropriate primer.

c. Joint and Crack Preparation:

- 1) Joints, cracks and fractures in the structural deck/substrate shall be prepared as defined below prior to installation of the Roofing system.
- 2) Non-Moving Cracks: Determine that crack is non-moving. Clean out crack by brushing and oil-free compressed air. Fill crack with polyurethane sealant. Allow for a minimum of twelve (12) hours cure or as required by sealant Manufacturer.
- 3) Moving Cracks: Determine that crack is moving. Clean out crack by brushing and oil-free compressed air. Fill crack with polyurethane sealant. Allow for a minimum of twelve (12) hours cure or as required by sealant Manufacturer. Following full cure of primer, apply resin and 4 inch wide strip of membrane (resin and fleece) in strict accordance with roofing system manufacturer's written instructions.

C. Primer Application:

1. General:

1. Mix and apply primer in strict accordance with written instructions of roofing system manufacturer. Use only proprietary materials, as supplied by the roofing system manufacturer.

1. The substrate surface must be dry, with any remaining dust or loose particles removed using clean, dry, oil-free compressed air, industrial vacuum, cloth wipe or a combination of methods.
2. Do not install primer on any substrate containing newly applied and/or active asphalt, coal-tar pitch, creosote or penta-based materials unless approved in writing by roofing system manufacturer. Some substrates may require additional preparation before applying primer.

D. Roofing System Application:

1. General:

1. It is recommended to apply the waterproofing membrane immediately following full curing of the primer in order to obtain the best bond between primer and membrane.
2. Mix and apply cold fluid-applied reinforced polymethyl methacrylate waterproofing membrane in strict accordance with written instructions of Membrane Manufacturer. Use only proprietary membrane resins and materials, as supplied by the membrane manufacturer.
3. The primed substrate surface shall be dry, with any remaining dust or loose particles removed using clean, dry, oil-free compressed air, industrial vacuum, cloth-wipe or a combination.
4. Protect all areas where membrane has been installed. Do not work off installed membrane during application of remaining work before twenty-four (24) hours of curing. Movement of materials and equipment across installed membrane is not acceptable. If movement is necessary, provide complete protection of affected areas.
5. Closely follow the Membrane Manufacturer's recommendation for hot and cold weather application. Monitor surface and ambient temperatures, including the effects of wind chill.

E. Flashing Application:

1. General:

1. Install flashing system in accordance with the requirements/recommendations of the roofing system manufacturer and as depicted on standard drawings and details. Provide system with base flashing, edge flashing, penetration flashing, counter flashing, and all other flashings required for a complete watertight system. Wherever possible, install the flashings before installing the field membrane to minimize foot traffic over newly installed field membrane.
2. All membrane flashings shall be installed concurrently with the roofing system as the job progresses. Temporary flashings are not allowed without prior written approval from the roofing system manufacturer. Should any water penetrate the roofing system membrane because of incomplete flashings, the affected area shall be removed and replaced at the Contractor's expense.
3. Provide a minimum vertical height of 8" for all flashing terminations, unless specifically detailed otherwise. Flashing height shall be at least as high as the potential water level that could be reached as a result of a deluging rain and/or poor slope. Do not flash over existing through-wall flashings or weep holes.
4. All flashings shall be terminated as required by the roofing system manufacturer.

2. Membrane Flashing – General:

1. Membrane flashings shall be fabricated with primer appropriate for the substrate surface, resin of the same base chemical type as the field membrane, and fleece of the same weight as the field membrane unless specified otherwise.
2. Primer, resin, and fleece mixing and application methods as specified for field membranes are also suitable for membrane flashing.
3. Fleece shall overlap 2 inches minimum for all joints. Fleece shall be cut neatly to fit all flashing conditions without a buildup of multiple fleece layers. Work wet membrane with a brush or roller to eliminate blisters, openings, or lifting at corners, junctions, and transitions.

3. Pipes, Conduits, and Unusually Shaped Penetrations:

1. Flash all penetrations using cold liquid-applied reinforced unsaturated polyester roof membrane with approved broadcast mineral aggregate surfacing or aliphatic polyester polyurethane coating. Flashing material shall be the same resin used in the field membrane with 165 fleece reinforcement.
2. Flashing is typically constructed as a two part assembly consisting of a vertical wrap and a horizontal target patch. There must be a minimum of a two (2) inch overlap between vertical and horizontal flashing components.

4. Curb and Base Flashings:

1. Wall, curb and base flashings shall be installed to solid substrate surfaces only. Adhering to gypsum-based panels, cementitious stucco, synthetic stucco, wood or metal siding, and other similar materials is not acceptable.
2. Reinforce all transition locations and other potential wear areas with a four (4) inch wide membrane strip evenly positioned over the transition prior to installing the exposed flashing layer.

3. Reinforce all inside and outside corners with a four (4) inch diameter conical piece of membrane prior to installing the exposed flashing layer.
4. All pins, dowels and other fixation elements shall be flashed separately with a vertical flashing component prior to installing the exposed flashing layer.
5. Extend flashing a minimum of four (4) inches onto the field substrate surface.

F. Surfacing and Finishes:

1. Provide and install approved kiln-dried mineral surfacing with dry roller to achieve non-skid surface. Note: surfacing is considered a non-warranty maintenance item, and will require re-application periodically.
2. Broadcast specified and approved sand or aggregate in excess into a bonding coat application of Membrane Manufacturer's approved methyl methacrylate-based aggregate coating system applied over clean, cured membrane at the manufacturer's recommended application rate. Aggregate shall be applied to excess to obtain uniform and full coverage.
3. Following minimum 2 hour cure time remove loose/un-embedded mineral aggregate by blowing with oil-free compressed air or with a vacuum. Re-broadcast clean mineral aggregate as required to provide full embedment and coverage of membrane.
4. Seal aggregate surface with a sealing coat application of Membrane Manufacturer's approved aggregate coating, applied at the manufacturer's recommended application rate. After completion of surfacing, avoid any traffic for a minimum of three (3) hours to allow for surfacing to cure.

G. Temporary Closures & Waterstops: Contractor shall be responsible to ensure that moisture does not damage any completed section of the new waterproofing system. Completion of flashings, terminations, and temporary closures shall be completed as required to provide a watertight condition. All temporary closures shall be made as recommended or required by the roofing system manufacturer.

H. Protection: Upon completion of roofing and flashings (including all associated work), institute appropriate procedures for surveillance and protection of roofing during remainder of construction period. Protect all areas where roofing has been installed.

I. Closeout:

1. Correction of Work: Work that does not conform to specified requirements including tolerances, slopes, and finishes shall be corrected and/or replaced. Any deficiencies of roofing system application, termination and/or protection as noted during the roofing system manufacturer's inspections shall be corrected and/or replaced at Contractor's expense.
2. Clean-Up: Site clean-up, including both interior and exterior building areas that have been affected by construction, shall be restored to pre-construction condition.

10.16 PAYMENT: Payment for liquid-applied roofing system shall be made at the respective Lump Sum Bids as specified in the offer schedule. Payment shall represent full compensation for

furnishing all labor, tools, equipment, material and incidentals necessary to complete the liquid-applied roofing in place complete, in accordance with the plans and specifications.

END OF SECTION



## SECTION SP-11-EXTERIOR COATINGS

### 11.01 GENERAL

- A. This section covers furnishing of labor, tools, equipment, materials and applying paint to the exterior reservoir wall, bottom of roof overhang, roof hatch, roof railing, ladder and other elements of the reservoir specified to have a paint finish in place complete, as shown on the plans and as specified in DIVISION 300 - CONSTRUCTION, Section 303.27 PAINTING of the Water System Standards, 2002, and as amended hereinafter as they apply to this project.
- B. Protection of Materials: All material shall be delivered to the jobsite in their original unopened containers bearing the manufacturer's name, brand and batch number. All coatings and paints shall be stored in enclosed structures to protect them from weather and excessive heat and cold. Flammable coatings or paints must be stored in conformance with city, county and state safety codes for flammable coating or paint materials.
- C. Substitutions: Requests for material substitutions must be made and approved in writing by Department of Water.

### 11.02 SUBMITTALS

- A. Submit product data in accordance with these Specifications. Unless otherwise specified here-in, submit manufacturer's data sheets showing the following information:
  - 1. Percent solids by volume.
  - 2. Minimum recommended dry-film thickness per coat for prime, intermediate and finish coats.
  - 3. Recommended surface preparation.
  - 4. Recommended thinners.
  - 5. Statement verifying that the specified prime coat is recommended by the manufacturer for use with the specified intermediate and finish coats.
  - 6. Application instructions including recommended equipment and temperature limitations.
  - 7. Verification from the manufacturer that the product meets current California VOC requirements.
  - 8. Color chips for alkyd enamel and exterior tank coatings.
- B. Painting Contractor experience documentation as described in Section 11.03 below.

### 11.03 PAINTING CONTRACTOR QUALIFICATIONS

- A. The Painting Contractor must be capable of performing the various items of work as specified. If required by the Manager, the Painting Contractor shall furnish a statement covering experience on similar work, a list of machinery and other equipment available for the proposed work, and a financial statement, including a complete statement of the Painting Contractor's financial ability and experience in performing similar painting and coating work.
- B. The Painting Contractor shall have a minimum of five (5) years practical experience and a successful history in the application of the specified products to concrete surfaces.
- C. Upon request, the Painting Contractor shall substantiate this requirement by furnishing a list of references, which shall include jobs of similar nature, listing name of project, year completed, owner, name and contact telephone number for reference for each project listed.

#### 11.04 MATERIALS

##### A. Aboveground Exterior Wall and Roof Overhang Areas:

1. Prime Coat - (1) coat, ICI Devoe Coatings 4030 TRU-GLAZE-WB Waterborne Epoxy Primer at 4.0 - 8.0 mils wet; 2.0 - 4.0 mils DFT. (200-270 sf/gal.) or approved equal.
2. Finish Coat- (2) coats, Glidden Fortis 350 (formerly ICI Devoe Coatings 2406 Dulux Professional) Waterborne Acrylic Latex Semi-Gloss at 4.0–4.6 mils wet; 1.4-1.6 mils DFT. (350-400 sf/gal) or approved equal.
3. The finish coat color shall match the existing tank color.

##### B. Metal Substrate:

1. Surface Preparation: ICI Devoe Devprep 88 Heavy Duty Cleaner or approved equal.
2. Prime Coat - (1) coat, ICI Devoe Bar-Rust 235 Multi-Purpose Epoxy Coating at 5.9 - 11.7 mils wet; 4.0 - 8.0 mils DFT. or approved equal.
3. Finish Coat- (2) coats, ICI Devoe Devthane 359 Aliphatic Urethane Gloss Enamel at 6.7–10.0. mils wet; 4.0-6.0 mils DFT. or approved equal.
4. The finish coat color shall match the existing tank color.

#### 11.05 EXECUTION

A. Sequence of Work: The exterior coating shall be applied after a successful reservoir leak test, and prior to performing the disinfection of the reservoir per SP-14 LEAK TESTING & DISINFECTION FOR RESERVOIR REPAIR.

B. Equipment: The Contractor's coating and painting equipment shall be designed for application of materials specified and shall be maintained in first class working condition. Compressors shall have suitable traps and filters to remove water and oils from the air. Contractor's equipment shall be subject to approval of the Engineer.

##### C. Surface Preparation

1. Remove all existing lead-based and lead-containing paint to bare concrete or metal.
2. All concrete surfaces shall be prepared in accordance with the recommendations of the coating manufacturer.
3. The surfaces shall be thoroughly cleaned, if they are not free of grease, curing compounds or other deleterious matter, as recommended by the coating manufacturer.
4. All metal surfaces to be painted shall be dry, clean and free from dirt, oil, grease, rust, scale or other foreign matters.
5. See Section SP-4 of these special provisions for lead-based and lead-containing paint removal requirements.

D. Application

1. Contractor shall comply with manufacturer's recommended application rates, methods, and instructions.
2. Each coat shall be free of runs, skips or "holidays".
3. All work shall be done in accordance with the manufacturer's safety recommendations, adequate ventilation shall be provided within the tank by the contractor during the course of interior painting work.

E. Surfaces Not To Be Coated

The following surfaces shall not be painted and shall be protected during the surface preparation and painting of adjacent areas:

1. Mortar-coated pipe and fittings.
2. Stainless steel, aluminum, brass or copper.
3. Metal letters.
4. Nameplates.
5. Grease fittings.
6. Buried pipe, unless specifically required in the piping specifications.

11.06 PROTECTION OF SURFACES NOT TO BE PAINTED

- A. Remove, mask, or otherwise protect hardware, lighting fixtures, switch plates, aluminum surfaces, machined surfaces, couplings, shafts, bearings, nameplates on machinery, and other surfaces not intended to be painted.
- B. Provide drop cloths to prevent paint materials from falling on or marring adjacent surfaces.
- C. Protect working parts of mechanical and electrical equipment from damage during surface preparation and painting process.
- D. Mask openings in motors to prevent paint and other materials from entering the motors.

11.07 THINNING

The Contractor shall not add thinner to any paint product without prior approval of the Engineer and the paint manufacturer. Only thinner manufactured by the paint manufacturer will be allowed if thinning is approved.

11.08 WEATHER CONDITIONS

- A. No painting shall be done under unfavorable weather conditions unless the work is well-protected from such conditions, and then only with the specific approval of the Officer-in-Charge.
- B. No painting shall be done when the air temperature is less than 50 degrees Fahrenheit (F), when the relative humidity is greater than 70 percent, or when the surface temperature is less than 5 degrees F above the dew-point, unless otherwise approved by the Officer-in-Charge. If dew or moisture condensation should be anticipated and if such conditions are prevalent, painting should be delayed until surfaces are dry. Further, the day's painting should be

completed in advance of the problem time when condensation will occur, in order to permit the film sufficient drying time prior to the formation of moisture.

- C. No painting shall be applied on any surface whose temperature is less than 50 degrees F or more than 120 degrees F or in conflict with the manufacturer's recommendations, unless otherwise approved by the Officer-in-Charge.

#### 11.09 SAFETY

- A. In accordance with requirements of the latest revision of the OSHA Regulations for Construction, the Contractor shall provide and require use of personal protective life-saving equipment for persons working in or about the project site.
- B. Head and Face Protection and Respiratory Devices: Equipment shall include protective helmets conforming to the requirements of ANSI Standard Z89.2, and shall be worn by all persons while in the vicinity of the work. In addition, workers engaged in or near the work during sandblasting shall wear eye and face protection devices meeting the requirements of ANSI Standard Z87.1 and OSHA Regulations for Sandblasting Operations, and air-purifying half-mask or mouthpiece respirator with appropriate filter.
- C. Ventilation: Where ventilation is used to control potential exposure as set forth in section 1910.924 of the OSHA Regulations for Construction, ventilation shall reduce the concentration of air contaminant to the degree a hazard does not exist.
- D. Sound Levels: Whenever the occupational noise exposure exceeds the maximum allowable sound levels as set forth in Table D-2 of Subpart C, Section 1926.52 of the OSHA Regulations for Construction, the Contractor shall provide and require the use of approved ear protection devices.
- E. Illumination: Adequate illumination shall be provided while work is in progress. Whenever required by the Officer-in-Charge, the Contractor shall provide additional illumination and necessary supports to cover all areas to be inspected. The level of illumination for inspection purposes shall be determined by the Officer-in-Charge.
- F. Temporary Ladders and Scaffolding: All temporary ladders and scaffolding shall conform to the applicable requirements of Subpart L, Sections 1926.45 and 1926.451 of the OSHA Regulations for Construction. They shall be erected where requested by the Officer-in-Charge to facilitate inspection and be removed by the Contractor to locations requested by the Officer-in-Charge.

- 11.10. PAYMENT: Payment for the application and furnishing of the Exterior Coatings in this section shall be made at the respective Lump Sum Bids as specified in the offer schedule. Payment shall represent full compensation for furnishing all labor, tools, equipment, material and incidentals necessary to complete the exterior coating, in accordance with the plans and specifications.

END OF SECTION

## SECTION SP 12 – NATIONAL POLLUTANT DISCHARGE ELIMINATION SYSTEM

### 12.01 HYDROTESTING EFFLUENT DISCHARGE:

- A. General Provisions: This item of work shall include the furnishing of all labor, materials, tools, and equipment necessary for construction water disposal.
- B. Regulations:
  - 1. The Contractor shall be familiar with and meet the latest requirements of all applicable National Pollutant Discharge Elimination System (NPDES), State Department of Health (DOH), and State Department of Transportation (DOT) ordinances, rules, regulations and permits. Effluent discharge into State receiving waters shall not be made without approved permits. Discharge activities shall include, but shall not be limited to, effluent associated with pipeline hydrotesting/chlorination operations.
  - 2. The Contractor shall obtain all permits and licenses, pay all charges, fees, and taxes, give all notices and comply with all laws, ordinances, rules and regulations bearing on the conduct of the work as drawn and specified in the contract documents.
- C. Procedures:
  - 1. The DOW has applied for and was granted a NPDES General Permit, File No. HI 18FF738 authorizing discharges of hydrotesting effluent associated with the construction activities from the project.
  - 2. The Contractor is expected to comply with the conditions set forth in the permit. Any modifications or amendments to the permit by the Contractor shall be done at the Contractor's expense and no time extension will be granted. The DOW shall approve all modifications or amendments.
  - 3. The Contractor shall make no claims for compensation due to delays or requirements imposed in obtaining an approved NPDES permit. Notice to Proceed will not be delayed due to Contractor's inability to attain an approved NPDES permit.
  - 4. As required for the discharge of effluent, the Contractor shall also secure all other applicable State and County discharge and connection permits and pay all applicable fees. The Contractor shall fulfill all conditions of the NPDES Permit and all other permits when issued. A copy of all approved permits, when issued, shall be provided to the DOW for information only.
  - 5. If additional NPDES coverages are required, the Contractor shall secure the applicable permits and obtain additional approvals, as necessary. A copy of all approved permits, when issued, shall be provided to the DOW for information only.
  - 6. The Contractor shall be responsible for monitoring, collecting samples, and having samples analyzed by a qualified laboratory and submit the analysis report to DOH. All costs shall be borne by the Contractor.
  - 7. If the DOH is not completely satisfied with the Contractor's BMP Plan or the discharge quality, the Contractor shall do corrective work at his/her own expense.

8. Upon completion of the project, the Contractor shall submit the Notice of Cessation (CWB-NOC) form to the DOH and a copy of the submitted form to the DOW for information only.
- D. Completion of Discharge Activities: At the conclusion of the discharge operations, the Contractor shall furnish the DOW with a signed affidavit indicating the date, location, volume, and treatment, if any, of all discharges. The location of storm drains, bodies of water, sewer manholes, and dry gulches shall be shown in relation to the discharge location.
- E. Violations: Violation citations for non-compliance shall be the responsibility of the Contractor. The Contractor shall pay all fines and hold harmless the Department of Water.
- F. Payment: Payment for the work described herein shall not be made directly but shall be considered incidental to the various items of the offer schedule and no additional compensation shall be made.

#### 12.02 STORM WATER DISCHARGE:

- A. General Description: This item of work shall include the furnishing of all labor, materials, tools, and equipment necessary for compliance with State of Hawai'i Department of Health regulations for discharges composed of storm water runoff associated with construction activity.
- B. Regulations:
  1. The Contractor shall be familiar with and meet the latest requirements of all applicable National Pollutant Discharge Elimination System (NPDES), State Department of Health (DOH), State Department of Transportation (DOT), and the Kaua'i County Department of Public Works (DPW) law, ordinances, rules, regulations and permits.
  2. The Contractor shall obtain all permits and licenses pay all charges, fees, and taxes, give all notices and comply with all laws, ordinances, rules and regulations bearing on the conduct of the work as drawn and specified in the contract documents.
- C. Determination: This project will not require the preparation of a construction site Best Management Practices (BMP) plan under the DOH NPDES regulations. The project affects a total land area less than the maximum disturbance area allowed for exemption from NPDES requirements. If the Contractor's work/staging area extends beyond the project work area, increasing the total disturbed land area beyond the maximum disturbance area allowed for exemption from NPDES requirements, the Contractor shall apply for and obtain an NPDES General Permit, Authorizing Discharges of Storm Water Associated with Construction Activity.

**Note: Although storm water discharge NPDES is not required, the Contractor is still required to have construction site Best Management Practices (BMP) in place for the duration of the project.**

- D. Procedures:

1. If other NPDES coverages are required for construction activities, the Contractor shall secure the applicable permits and obtain additional approvals, as necessary. A copy of all approved permits, when issued, shall be provided to the DOW for information only.
  2. The Contractor is expected to comply with the conditions set forth in the permit. Any modifications or amendments to the permit by the Contractor shall be done at the Contractor's expense and no time extension will be granted. The Department of Water shall approve all modifications or amendments.
  3. The Contractor shall make no claims for compensation due to delays or requirements imposed in obtaining an approved NPDES permit. Notice to Proceed will not be delayed due to Contractor's inability to attain an approved NPDES permit.
  4. The Contractor shall be responsible for monitoring, collecting samples, and having samples analyzed by a qualified laboratory and submit the analysis report to DOH. All costs shall be borne by the Contractor.
  5. If the DOH is not completely satisfied with the Contractor's BMP plan or the discharge quality, the Contractor shall perform corrective work at their own expense.
  6. Upon completion of the project, the Contractor shall submit the Notice of Cessation (CWB-NOC) form to the DOH and a copy of the submitted form to the DOW for information only.
- E. Violations: Violation citations for non-compliance shall be the responsibility of the Contractor. The Contractor shall pay all fines and hold harmless the Department of Water.
- F. Payment: Payment for the work described herein shall not be made directly but shall be considered incidental to the various items of the offer schedule and no additional compensation shall be made.

END OF SECTION

## SECTION SP-13 – DISCHARGING PCB-CONTAINING WATER

### 13.01 GENERAL

1. This section covers furnishing of labor, tools, equipment, materials necessary for the discharging and disposal of PCB-containing water from the existing reservoir as described in this special provision and as shown on the Project Drawings.
  - B. The Contractor shall review and follow the approved Workplan in the “USEPA Conditional Approval of PCB Cleanup Plan under TSCA 761.61(c) for Paua Valley Tank #1, Kekaha, Kaua’i, Hawai’i,” dated October 16, 2018, for discharging the PCB-containing water from the existing reservoir and disposing of PCB waste.

### 13.02 SUBMITTALS

- A. Submit product data in accordance with these Specifications for the following:
  1. Activated Carbon Filter Drum
  2. Sump Pump
  3. Chlorosulfonated Polyethylene (CSPE) Reinforced Sheet

### 13.03 PRODUCTS

1. Activated Carbon Filter Drum: A liquid phase activated carbon adsorption system for environmental remediation and institutional water conditioning applications. The steel drum shall be able to contain 150-200 pounds of virgin activated carbon 8x12 mesh design, capable of handling a flow of at least 10 gpm, with a maximum operating pressure of 6 psi. This manufactured assembly can be purchased from the following manufacturers:
  1. “Econosorb-LS”, by TIGG Corporation, 1 Willow Avenue, Oakdale, PA, Phone: (724) 703-3020, [www.tigg.com](http://www.tigg.com).
  2. “Water Purification Canister L-1”, by Carbtrol Corporation, 955 Connecticut Ave., Suite 5202, Bridgeport, CT 06607, Phone: (800) 242-1150, [www.carbtrol.com](http://www.carbtrol.com).
  3. Approved Equal
4. Sump Pump: A submersible sump pump capable of discharging water at a minimum of 10 gpm.
5. CSPE Reinforced Sheet: The 30 mil CSPE membrane shall be reinforced with a polyester scrim fabric and manufactured by the calandar process, provided by the following manufacturers:
  1. Burke Industries Inc., Roofing and Environmental Products, 2250 South Tenth Street, San Jose, CA 95112, Phone: (800) 669-7010, [www.burkeind.com](http://www.burkeind.com).
  2. Approved Equal
3. Pipe and Pipe Fitting: Materials used for pipes and pipe fittings shall be provided as approved in the Water System Standards, 2002, as amended hereafter, and as they apply to this project and as shown on the Drawings.



#### 13.04 EXECUTION

1. The slopes of the excavated pit shall be compacted to prevent sloughing.
2. Install CSPE sheet wrinkle-free in the excavated pit. CSPE sheet field seams shall be sealed with either heat welding or solvent adhesive. The seal at all seams shall be per manufacturer's recommendations and shall be continuous and watertight.
3. The edges of the CSPE sheet shall be secured outside of the excavated pit in a manner to prevent the liner from shifting.
4. Install sump pump pipe outlet to discharge water away from the excavated pit and into the drainage ditch.
5. For discharging of water from the reservoir, see the "Reservoir Water (Containing PCB) Discharge Notes" in the Project Drawings for Discharge Location and Schedule, Activated Carbon Filter System, and Sample Collection and Laboratory Analysis.
6. The discharged water with PCB levels below the allowable limits shall be discharged and disposed of appropriately per the requirements in SP-12 - NATIONAL POLLUTANT DISCHARGE ELIMINATION SYSTEM.
7. Following the water discharging operations, restore piping and grade to previous conditions or better, acceptable to DOW. The excavated pit shall be backfilled with the native soil and rocks and compacted to minimize future erosion in stream bed.

#### 13.05 PAYMENT

Payment for discharging of PCB-contaminated water from the reservoir shall be made at the respective Lump Sum Bids as specified in the offer schedule. Payment shall represent full compensation for furnishing all labor, tools, equipment, material and incidentals necessary to complete the water discharge, in accordance with the plans and specifications.

END OF SECTION

## SECTION SP-14 LEAK TESTING & DISINFECTION FOR RESERVOIR REPAIR

### 14.01. GENERAL

1. This item of work shall be in accordance with the Department of Water, Water System Standards Section 303.10, and as supplemented herein.
1. This item of work shall include the furnishing of all labor, materials, tools, and equipment necessary to perform the leak testing and disinfection of the reservoir as specified hereafter and as they apply to this project and as shown on the Project Drawings.
2. The disinfection procedures shall not be done concurrently with the leakage test. The leakage test shall be done first, followed by the application of the interior and exterior coating as required, then followed by disinfection.
3. Contractor shall submit to the Officer-in-Charge for approval, a plan and schedule indicating in detail the method or steps by which the Contractor proposes to accomplish the chlorination work of this special provision. The plan shall be approved prior to any chlorination work being performed.

#### 4. Sequence of Work

1. The work of this section shall not proceed until the DOW has accepted the condition of the reservoir interior.
2. The reservoir joint seal replacement per SP-8 shall be done prior to the leak testing.

#### 3. Leak Testing

1. Before filling the reservoir for the leakage test, the reservoir shall be cleaned of all debris.
2. The leak test shall consist of filling the reservoir in 5-foot increments up to its overflow level and observing for any visible leaks on the exterior surfaces after each increment and at the end of 7 days.
3. After the reservoir has passed the 7-day leak test period, the reservoir shall be emptied and prepared for interior coating and exterior painting per SP-9 PROTECTIVE COATINGS and SP-11 EXTERIOR COATINGS, respectively.

#### 4. Disinfection

1. The disinfection of the reservoir shall not proceed until the DOW has accepted the condition of the reservoir interior and exterior work.
2. After the reservoir has been cleaned of any debris and the walls hosed down with chlorinated water with at least a concentration of 50 mg/liter, the floor shall be scrubbed and hosed down with wash water used for the walls and flushed through the washout. The washout valve shall be closed and the line filled with water up to the floor level. The valve shall then be opened, and the washout drained removing any debris in the line.

3. The reservoir shall be filled to its overflow level, and a hypochlorite solution shall be added to the reservoir contents and water samples taken as described in the Water System Standards, Section 303.10.B.3.d. A second test after the 7-day period shall be taken 20 to 28 hours later as again described in the Water System Standards.
4. If any water sample fails to meet the criteria specified in the Water System Standards, the disinfection of the reservoir shall be repeated as directed by the Officer-in-Charge. After the reservoir is re-disinfected, new water samples shall be collected.

#### 14.02 PAYMENT

Payment for leak testing and disinfection, and specified sampling and testing shall be made at the respective Lump Sum Bids as specified in the offer schedule. Payment shall represent full compensation for furnishing all labor, tools, equipment, material and incidentals necessary to complete the leak testing and disinfection, in accordance with the plans and specifications.

END OF SECTION

## SECTION SP-15 – MISCELLANEOUS METAL FABRICATION

### 1. GENERAL

1. Description: The Work of this Section shall include the furnishing of all labor, materials, tools and equipment necessary for completing metal item fabrication, such as stainless steel ladder, water level indicator support system, and installation complete covered in this specification, and as specified hereafter and in accordance with Water System Standards, 2002, as amended hereafter, as they apply to this project and as shown on the drawings.

### 2. SUBMITTALS:

1. Shop Drawings: Detail fabrication and erection of each metal fabrication member indicated. Include plans, elevations, sections, and details of metal fabrication members and their connections. Show anchorage and accessory items.
2. Provide templates for anchors and bolts specified for installation to be coordinated with other work.
3. Manufacturer's installation instructions and rough-in dimensions for manufactured items.
4. Welding Certificates: Copies of certificates for welding procedures and personnel.
5. Qualification Data: For firms and persons specified in "Quality Assurance" Article to demonstrate their capabilities and experience. Include lists of completed projects with project names and addresses, names and addresses of architects and owners, and other information specified.

### 3. QUALITY ASSURANCE

1. Fabricator Qualifications: A firm experienced in producing metal fabrications similar to those indicated for this Project and with a record of successful in-service performance, as well as sufficient production capacity to produce required units within the project schedule.
2. Welding: Qualify procedures and personnel according to the following:
  1. AWS D1.1, "Structural Welding Code--Steel."
  2. AWS D1.6, "Structural Welding Code—Stainless Steel."
  3. Certify that each welder has satisfactorily passed AWS qualification tests for welding processes involved and, if pertinent, has undergone recertification.
3. If epoxy anchors are installed, Contractor shall arrange for special inspection for their installation. Deputy inspector's report shall be submitted to the Officer-in-Charge.

### 4. DELIVERY, STORAGE AND HANDLING

1. Exercise proper care in handling of Work so as not to damage finished surfaces. Protect Work from damage after it is in place.

2. Store materials under cover in a dry and clean location off the ground in manner that will not distort and bend assembly. Remove materials that are damaged or otherwise not suitable for installation from job site and replace with acceptable materials at no additional cost to Department of Water.

#### 5. PROJECT CONDITIONS

1. Field Measurements: Where metal fabrications are indicated to fit walls and other construction, verify dimensions by field measurements before fabrication and indicate measurements on Shop Drawings. Coordinate fabrication schedule with construction progress to avoid delaying the Work.

#### 6. COORDINATION

1. Coordinate installation of anchorages for metal fabrications. Furnish setting drawings, templates, and directions for installing anchorages, including sleeves, concrete inserts, anchor bolts, and items with integral anchors, that are to be embedded in concrete. Deliver such items to Project site in time for installation.

#### 7. SCHEDULING

1. Schedule installation of ladders for mounting to occur only to completed concrete construction with required curing time. Do not support temporarily by any means that does not satisfy structural performance requirements.

#### 8. MATERIALS

1. Stainless-Steel Bars and Shapes: ASTM A276, Type 316L, unless noted otherwise.
2. Stainless Steel Sheet, Strip, and Plate: ASTM A666, Type 316L, unless noted otherwise.
3. Stainless Steel Pipes: ASTM A312, Grade TP 316L, unless noted otherwise
4. Stainless Steel threaded rod: ASTM F593 (AISI 316).
5. Welding Rods and Filler Metal: Provide type and alloy of filler metal and electrodes as recommended by producer of metal to be welded and as required for color match, strength, and compatibility in fabricated items. Select according to AWS specifications for metal alloy welded.
6. Structural Adhesive Epoxy: Factory-packaged, two-component, non-shrink, low-odor, 100% solids epoxy-based adhesive for use as a structural adhesive with a current ICC Evaluation Services, ES Report for both cracked and un-cracked concrete, such as Simpson "SET-XP" or Hilti "HIT RE 500-SD" or approved equal.

#### 9. STAINLESS STEEL LADDER

1. Fabricate ladder for location shown, with dimensions, spacing, details, and anchorages as indicated and in accordance with WSS Section 303.22.G.

2. Siderails: Continuous stainless steel pipe section, size and spaced as indicated on Drawings.
3. Bar Rungs: 3/4-inch minimum diameter solid steel bars, spaced 12 inches on center. Provide non-slip surfaces on top of each rung by coating with abrasive material bonded to rung by a proprietary process designed for use in potable water or the surface can be knurled to provide a slip-resistant textured surface.
4. Fit rungs in centerline of side rail pipes; insert rung 1 inch minimum into pipe section; fillet weld circumference of rung.
5. Support ladder at top and bottom as detailed on Drawings.
6. Measure existing conditions to provide connection plates and ladder of proper length and orientation to properly fit. Verify fit-up before installing epoxy anchors.
7. After ladder position is plumb and straight, the expansion anchors shall be installed to anchor the ladder as shown in the Drawings.
8. All anchor bolts shall be located to avoid drilling through embedded reinforcing steel.

#### 10. FASTENERS

1. General: Provide Type 316 stainless-steel fasteners or as specified on construction documents.
2. Bolts and Nuts: Type 316 stainless steel hexagon-head bolts, ASTM F597 with Teflon-coated hex nuts, ASTM F 597, where indicated, flat washers.
3. Lock Washers: Helical, spring type, stainless steel.
4. Expansion Anchors: Anchors shall be constructed from stainless steel, Type 316, designed to be installed in cracked or uncracked concrete with a current ICC Evaluation Services, ES Report, such as Simpson “Strong Bolt 2” or Hilti “Kwik Bolt TZ SS 316,” or approved equal.

#### 11. STEEL FABRICATION – GENERAL

1. Preassemble items in shop to greatest extent possible to minimize field splicing and assembly. Disassemble units only as necessary for shipping and handling limitations. Use only welded connections for steel member connections. Clearly mark units for reassembly and coordinated installation.
2. Fabricate metal items to comply with indicated dimensions, member sizes and spacing, details, finish, and anchorage.
3. Ease exposed edges to a radius of approximately 1/32 inch, unless otherwise indicated. Form bent-metal corners to smallest radius possible without causing grain separation or otherwise impairing work. Shear and punch metals cleanly and accurately. Remove burrs.

4. Welded Connections: Fabricate ladder by welding members. For all welded connections, cope components at perpendicular and skew connections to provide a close fit. Weld connections continuously to comply with the following:
  1. Use materials and methods that minimize distortion and develop strength and corrosion resistance of base metals.
  2. Obtain fusion without undercut or overlap.
  3. Remove welding flux immediately.
  4. At exposed connections, finish exposed welds and surfaces smooth and blended so no roughness shows after finishing and contour of welded surface matches that of adjacent surface.
  5. Fabricate joints in a watertight manner.
  6. Form work true to line and level with accurate angles and surfaces and straight sharp edges.
  7. Remove sharp or rough areas on exposed traffic surfaces. Close exposed ends of railing members with fitted and welded ends.
  8. For stainless steel members that are welded, provide passivation in accordance with ASTM A380 after fabrication.

12. DISSIMILAR METAL SEPARATION

1. For member-to-member contact, provide two layers of separation tape between dissimilar metals.
2. For fasteners of dissimilar metal relative to the base material, provide insulating washers under nuts and bolt or screw heads designed to separate dissimilar metals.

13. PAYMENT:

Payment for MISCELLANEOUS METAL FABRICATION and all specified finishes shall be made at the respective Lump Sum Bids as specified in the offer schedule. Such payment shall represent full compensation for furnishing all materials, labor, tools, equipment and incidentals to complete the work.

END OF SECTION

SECTION SP-16 – FIELD OFFICE

16.01 GENERAL

- A. A field office is required for this project. It shall be furnished per section 6.3 of the General Provisions for Construction Contracts with the Department of Water. Contractor shall be responsible for all associated costs for the field office.

16.02 PAYMENT

- A. Unless otherwise specified, payment for field office shall not be measured nor paid for directly but shall be considered incidental to the construction work.

END OF SECTION



**APPENDIX N: Environmental Protection Agency Documents (Bound Separately).**

# IFB Job No. 17-10 Appendix A-Sample Contract



CONTRACT NO. [Click here to enter text.](#)

## CONSTRUCTION CONTRACT

THIS CONTRACT, effective as of the date below, is made and entered into by and between the BOARD OF WATER SUPPLY, County of Kaua'i, whose mailing address is 4398 Pua Loke Street, Līhu'e, Hawai'i 96766 (hereinafter the "BOARD") and [Click here to enter text.](#), a [Click here to enter text.](#), under the laws of the State of Hawaii, whose principle mailing address is [Click here to enter text.](#) (hereinafter the "CONTRACTOR").

### RECITALS

THIS CONTRACT for construction services has been procured under:

- HRS §103D-302 (Competitive Sealed Bidding)
- HRS §103D-303 (Competitive Sealed Proposals)
- HRS §103D-305 (Small Purchase)
- HRS §103D-307 (Emergency Procurement No. [Click here to enter text.](#))

WHEREAS, ; and

WHEREAS, the Contractor is able and qualified to provide such construction services as required in this Contract; and

NOW THEREFORE, in consideration of the payment(s) hereinafter set forth to be made by the Board, the Contractor agrees to furnish and pay for all materials, supplies, tools, equipment, labor, utilities, transportation, services, and any and all other incidentals necessary to construct in place and complete, free of all liens, claims, and any encumbrances whatsoever: **Click here to enter text.** (hereinafter "Project").

1. **Contract Documents.** The Contractor agrees to complete the Project in accordance with this Contract and the following documents:

- Approved construction drawings;
- Specifications;
- Invitation for Bids Document No. [Click here to enter text.](#) and all Addenda thereto;
- Request for Proposals Project No. [Click here to enter text.](#) and all Addenda thereto;
- Bid/Proposal/Best and Final Offer;

- Method of Award;
- Wage Rate Schedule;
- Construction Schedules;
- Special Provisions;
- General Provisions for Construction Contracts of the Department of Water, dated April 25, 2016;

and those other documents attached or referred to therein, relating to the Project (hereinafter collectively referred to as "Contract Documents"). The Contractor understands and agrees that the Contract Documents including, but not limited to, those referenced in but not attached to this Contract and those referenced in but not attached to the Contract Documents, are hereby incorporated by reference into this Contract. The Contractor acknowledges and admits receipt of all Contract Documents, and acknowledges that it has reviewed, understands, and agrees with all terms and conditions in the Contract Documents and those other documents, terms and conditions referenced therein.

2. **Time of Performance.** The Contractor agrees to complete the Project within [Click here to enter text.](#) **CALENDAR DAYS**, from and including the date as specified in the written Notice to Proceed.
  
3. **Compensation.** For and in consideration of the Contractor's full and faithful performance of all services required to be performed under the Contract Documents, the Board hereby agrees to pay the Contractor the total maximum sum of [Click here to enter text.](#) **DOLLARS** (**\$[Click here to enter text.](#)**), federal, state, and local taxes included, in lawful money of the United States of America. The Contractor understands and agrees that payment shall be made in the manner and at the times specified in the Contract Documents, and shall also be subject to and conditioned upon such additions to or deductions from the preceding sum as may herein be made, according to the Contract Documents.
  - a. **Cost and/or Pricing:** If this Contract required Cost and/or Pricing data, the Contractor understands and agrees that the price to the Board, including profit or fee, shall be adjusted to exclude any significant sums by which the Board finds that the price was increased because the Contractor furnished cost or pricing data that was inaccurate, incomplete, or not current as of the date agreed upon between the parties.
  
4. **Liquidated Damages.** The Contractor understands and agrees that time is an essential factor of this Contract, and that the Board will suffer material loss by reason of delays that may occur in the Contractor's performance of the work or any portions of the work within the time or times fixed in the Contract or any extensions thereto. When the Contractor is given notice of delay or nonperformance, as specified in the Termination for Default clause of this Contract, and fails to cure in the time specified, the Contractor shall pay to the Board, as liquidated damages for any such delays or nonperformance, the sum of **[Click here to enter text.](#) DOLLARS** (**\$[Click here to enter text.](#)**), for each and every calendar day of delay or nonperformance from the day set for cure until either the Board reasonably obtains similar services if the Contract is terminated for default, or until

the Contractor provides the services if the Contractor is not terminated for default. The sums of each and every calendar day of delay or nonperformance shall be deducted from the Contract price. It is expressly stipulated by and between the Contractor and the Board that any such sums shall be deemed and taken to be liquidated damages for the Contractor's failure to perform within the specified time and not be in the nature of a penalty. To the extent that the Contractor's delay or nonperformance is excused under "excuse for nonperformance or delayed performance" of the Termination for Default clause of this Contract, liquidated damages shall not be due the Board. The Contractor remains liable for damages caused other than by delay.

5. **Bonds.** The Contractor is required to provide the following bonds, in an amount equal to 100% of the amount of the Contract price in the form(s) set forth in **Exhibit A**:

- Performance Bond (**Exhibit A1**)
- Labor and Material Payment Bond (**Exhibit A2**)
- Not Applicable

6. **Insurance.** Contractor shall procure and maintain, on a primary basis and at its sole expense, at all times during the life of the contract insurance coverages, limits, including endorsements as described Appendix "B" - Insurance, against claims for injuries to persons or damages to property which may arise from or in connection with the performance of the work by the Contractor or the Contractor's agents, representatives, employees, or subcontractors. The requirements contained therein, as well as the Department's review or acceptance of insurance maintained by the Contractor is not intended to and shall not in any manner limit or qualify the liabilities or obligations assumed by the Contractor. Unless otherwise approved by the Manager and Chief Engineer, the policy or policies of insurance maintained by the Contractor shall provide the minimum limit(s) and coverage(s) as specified in the attached Appendix "B" - Insurance and be placed with an insurance carrier authorized to do business in this state and rated A-VII by A.M. Best.

7. **Procurement Officer and Contract Administrator.** The Procurement Officer and Contract Administrator are:

If checked, the Procurement Officer and the Contract Administrator shall be the same individual.

Procurement Officer:

[Click here to enter text.](#)

[Click here to enter text.](#)

Department of Water, County of Kaua'i

4398 Pua Loke Street

Līhu'e, HI 96766

Phone: 808-245-[Click here to enter text.](#)

[Click here to enter text.](#)

Contract Administrator:

[Click here to enter text.](#)

[Click here to enter text.](#)

Department of Water, County of Kaua'i

4398 Pua Loke Street

Līhu'e, HI 96766

Phone: 808-245-[Click here to enter text.](#)

[Click here to enter text.](#)

8. **Severability.** In the event any term or provision of this Contract is declared to be invalid or illegal for any reason, this Contract will remain in full force and effect and will be interpreted as though such invalid or illegal provision were not a part of this Contract.
9. **Execution in Counterparts.** This Contract may be executed in counterparts, all of which shall be considered the same as if a single document shall have been executed, but shall become effective when such counterparts have been signed by each of the parties hereto and delivered to each party.
10. **Waiver.** Waiver of a breach or default under this Agreement shall not constitute a continuing waiver or a waiver of a subsequent breach of the same or any other provision of this Agreement.
11. **Board Defined.** As used in this Contract, “Board” means the Board of Water Supply of the County of Kaua‘i and the Department of Water, County of Kaua‘i, and its officers, agents, and employees.

**[REMAINDER OF THIS PAGE INTENTIONALLY LEFT BLANK]**

IN WITNESS WHEREOF, the parties hereto have hereunto caused this Contract to be executed as of the \_\_\_\_\_ day of \_\_\_\_\_, 20\_\_\_\_\_.

RECOMMENDED FOR APPROVAL

BOARD OF WATER SUPPLY,  
COUNTY OF KAUA'I

\_\_\_\_\_  
Bryan Wienand, P.E.  
Manager and Chief Engineer

\_\_\_\_\_  
Thomas Canute  
Chairperson, Board of Water Supply

APPROVED AS TO FORM  
AND LEGALITY

CONTRACTOR

\_\_\_\_\_  
Mahealani M. Krafft  
Deputy County Attorney

\_\_\_\_\_  
By: Click here to enter text.  
Its: Click here to enter text.

STATE OF HAWAI'I )  
 ) ss.  
COUNTY OF \_\_\_\_\_)

On this \_\_\_ day of \_\_\_\_\_, 20\_\_\_ in the \_\_\_ Circuit, State of Hawai'i, before me personally appeared \_\_\_\_\_, who is personally known to me or whose identity I proved on the basis of satisfactory evidence, who being by me duly sworn or affirmed, did say that such person executed the \_\_\_\_\_, dated \_\_\_\_\_ and consisting of \_\_\_ pages at the time of notarization, as the free act and deed of such person, and if applicable in the capacity shown, having been duly authorized to execute such instrument in such capacity.

\_\_\_\_\_  
Notary Public, State of Hawai'i  
Name of Notary: \_\_\_\_\_ (Affix Seal)  
My Commission expires: \_\_\_\_\_

***PLEASE INSERT YOUR APPLICABLE NOTARY SECTION***

**EXHIBIT A1  
PERFORMANCE BOND (SURETY)**

**KNOW ALL BY THESE PRESENTS:**

That Click here to enter text., a Click here to enter text. corporation, whose principal mailing address is Click here to enter text., as Principal, (hereinafter referred to as “Principal”), and Click here to enter text., as Surety, (hereinafter referred to as “Surety”), a corporation(s) authorized to transact business as a surety in the State of Hawai‘i, are held and firmly bound unto the Board of Water Supply, its successors and assigns, (hereinafter referred to as “Obligee”), in the amount of **Click here to enter text. DOLLARS (\$Click here to enter text.)** to which payment Principal and Surety bind themselves, their heirs, executors, administrators, successors and assigns, jointly and severally, firmly by these presents.

**WHEREAS**, the above-bound Principal has entered into a Contract with Obligee dated Click here to enter a date. for Click here to enter text. (hereinafter referred to as the “Contract”), which Contract is incorporated herein by reference and made a part hereof.

**NOW THEREFORE**, the condition of this obligation is such that:

If the Principal shall promptly and faithfully perform, and fully complete the Contract in strict accordance with the terms of the Contract as said Contract may be modified or amended from time to time; then this obligation shall be void; otherwise to remain in full force and effect. Surety to this bond hereby stipulates and agrees that no changes, extensions of time, alterations, or additions to the terms of the Contract, including the work to be performed thereunder, and the specifications or drawings accompanying same, shall in any way affect its obligation on this bond, and it does hereby waive notice of any such changes, extensions of time, alterations, or additions, and agrees that they shall become part of the Contract.

In the event of Default by the Principal, of the obligations under the Contract, then after written Notice of Default from the Obligee to the Surety and the Principal, Surety shall either remedy the Default, or take over the work to be performed under the contract and complete such work, subject, however, to the limitation of the penal sum of this bond.

Signed and sealed this \_\_\_\_\_ day of \_\_\_\_\_.





**EXHIBIT A1  
PERFORMANCE BOND**

**KNOW ALL BY THESE PRESENTS:**

That we, \_\_\_\_\_, whose mailing address is \_\_\_\_\_, as Contractor, (hereinafter called “Contractor”), is held and firmly bound unto the \_\_\_\_\_, its successors and assigns, as Obligee, (hereinafter called “Obligee”), in the amount of \_\_\_\_\_ **DOLLARS (\$\_\_\_\_\_)**, lawful money of the United States of America, for the payment of which to the said Obligee, well and truly to be made, Contractor binds itself, its heirs, executors, administrators, successors and assigns, firmly by these presents. Said amount is evidenced by:

- Legal tender;
- Share Certificate unconditionally assigned to or made payable at sight to \_\_\_\_\_;
- Certificate of Deposit, No. \_\_\_\_\_, dated \_\_\_\_\_, issued by \_\_\_\_\_, drawn on \_\_\_\_\_, a bank, savings institution, or credit union insured by the Federal Deposit Insurance Corporation or the National Credit Union Administration, payable at sight or unconditionally assigned to \_\_\_\_\_;
- Cashier's Check No. \_\_\_\_\_, dated \_\_\_\_\_, issued by \_\_\_\_\_, drawn on \_\_\_\_\_, a bank, savings institution, or credit union insured by the Federal Deposit Insurance Corporation or the National Credit Union Administration, payable at sight or unconditionally assigned to \_\_\_\_\_;
- Teller's Check No. \_\_\_\_\_, dated \_\_\_\_\_, issued by \_\_\_\_\_, drawn on \_\_\_\_\_, a bank, savings institution, or credit union insured by the Federal Deposit Insurance Corporation or the National Credit Union Administration, payable at sight or unconditionally assigned to \_\_\_\_\_;
- Treasurer's Check No. \_\_\_\_\_, dated \_\_\_\_\_, issued by \_\_\_\_\_;

\_\_\_\_\_, drawn on \_\_\_\_\_, a bank, savings institution, or credit union insured by the Federal Deposit Insurance Corporation or the National Credit Union Administration, payable at sight or unconditionally assigned to \_\_\_\_\_;

Official Check No. \_\_\_\_\_, dated \_\_\_\_\_, issued by \_\_\_\_\_, drawn on \_\_\_\_\_, a bank, savings institution, or credit union insured by the Federal Deposit Insurance Corporation or the National Credit Union Administration, payable at sight or unconditionally assigned to \_\_\_\_\_;

Certified Check No. \_\_\_\_\_, dated \_\_\_\_\_, issued by \_\_\_\_\_, drawn on \_\_\_\_\_, a bank, savings institution, or credit union insured by the Federal Deposit Insurance Corporation or the National Credit Union Administration, payable at sight or unconditionally assigned to \_\_\_\_\_.

**WHEREAS**, the Contractor has by written agreement dated \_\_\_\_\_ entered into a contract with Obligee for the following PROJECT: [Click here to enter text.](#), (hereinafter called the “Contract”), which Contract is incorporated herein by reference and made a part hereof.

NOW, THEREFORE,

The condition of this obligation is such that, if Contractor shall promptly and faithfully perform the Contract in accordance with, in all respects, the stipulations, agreements, covenants and conditions of the Contract as it now exists or may be modified according to its terms, and shall deliver the PROJECT to the Obligee, or to its successors or assigns, fully completed as in the Contract specified and free from all liens and claims and without further cost, expense, or charge to the Obligee, its officers, agents, successors, or assigns, free and harmless from all suits or actions of every nature and kind which may be brought for or on account of any injury or damage, direct or indirect, arising or growing out of the doing of said work or the repair or maintenance thereof or the manner of doing the same or the neglect of the Contractor or its agents or servants or the improper performance of the Contract by the Contractor or its agents or servants or from any other cause, then this obligation shall be void; otherwise it shall be and remain in full force and effect.

**AND IT IS HEREBY STIPULATED AND AGREED** that suit on this bond may be

brought before a court of competent jurisdiction without a jury, and that the sum or sums specified in the said Contract as liquidated damages, if any, shall be forfeited to the Oblige, its successors or assigns, in the event of a breach of any, or all, or any part of, the covenants, agreements, conditions, or stipulations contained in the Contract or in this bond in accordance with the terms thereof.

The amount of this bond may be reduced by and to the extent of any payment or payments made in good faith hereunder.

Signed this \_\_\_\_ day of \_\_\_\_\_, \_\_\_\_\_.

(Seal)

\_\_\_\_\_  
Name of Contractor

\_\_\_\_\_  
Signature

\_\_\_\_\_  
Title

STATE OF \_\_\_\_\_ )  
 ) ss.  
COUNTY OF \_\_\_\_\_ )

On this \_\_\_\_\_ day of \_\_\_\_\_, \_\_\_\_\_, before me appeared \_\_\_\_\_ to me personally known, who being by me was duly sworn, did say he/she is the \_\_\_\_\_ of \_\_\_\_\_, a \_\_\_\_\_; that the seal affixed to the foregoing instrument is the \_\_\_\_\_ seal of said \_\_\_\_\_; and said officer acknowledged said instrument to be the free act and deed of said \_\_\_\_\_.

\_\_\_\_\_  
Notary Public, State of \_\_\_\_\_

Name of Notary: \_\_\_\_\_

My commission expires: \_\_\_\_\_

***ALL SIGNATURES MUST BE ACKNOWLEDGED BY A NOTARY PUBLIC***

**EXHIBIT A2  
LABOR AND MATERIAL PAYMENT BOND (SURETY)**

**KNOW ALL BY THESE PRESENTS:**

That Click here to enter text. a Click here to enter text. corporation, whose principal mailing address is Click here to enter text. , as principal (hereinafter referred to as "Principal"), and Click here to enter text. as Surety (hereinafter referred to as "Surety"), a corporation(s) authorized to transact business as a surety in the State of Hawai'i, are held and firmly bound unto the Board of Water Supply, its successors and assigns (hereinafter referred to as "Obligee"), in the amount of Click here to enter text. **DOLLARS** (\$Click here to enter text.), to which payment Principal and Surety bind themselves, their heirs, executors, administrators, successors and assigns, jointly and severally, firmly by these presents.

**WHEREAS**, the above-bound Principal has entered into a Contract with Obligee dated Click here to enter a date. for Click here to enter text. (hereinafter referred to as the "Contract"), which Contract is incorporated herein by reference and made a part hereof.

**NOW, THEREFORE**, the condition of this obligation is such that if the Principal shall promptly make payment to any Claimant, as hereinafter defined, for all labor and materials supplied to the Principal for use in the performance of the Contract, then this obligation shall be void; otherwise to remain in full force and effect.

1. Surety to this Bond hereby stipulates and agrees that no changes, extensions of time, alterations, or additions to the terms of the Contract, including the work to be performed thereunder, and the specifications or drawings accompanying same, shall in any way affect its obligation on this bond, and it does hereby waive notice of any such changes, extensions of time, alterations, or additions, and agrees that they shall become part of the Contract.
2. A "Claimant" shall be defined herein as any person who has furnished labor or materials to the Principal for the work provided in the Contract.

As provided in Section 103D-324, Hawai'i Revised Statutes, every Claimant who has not been paid in full before the expiration of a period of ninety days after the day on which the last of the labor was done or performed or material was furnished or supplied, for which such a claims made, may institute an action against the Principal or the Principal and its Surety, on this bond

and have their rights and claims adjudicated in the action, and judgment rendered thereon; subject to the Obligee's priority on the bond. If the full amount of the liability of the Surety on the bond is insufficient to pay the full amount of the claims, then after paying the full amount due the Obligee, the remainder shall be distributed pro rata among the claimants.

Signed and sealed this \_\_\_\_\_ day of \_\_\_\_\_.

\_\_\_\_\_  
Principal Seal

By: \_\_\_\_\_

Its: \_\_\_\_\_

\_\_\_\_\_  
Surety Seal

By: \_\_\_\_\_

Its: \_\_\_\_\_

***ALL SIGNATURES MUST BE ACKNOWLEDGED BY A NOTARY PUBLIC***

SURETY LABOR AND MATERIAL PAYMENT BOND

STATE OF \_\_\_\_\_ )  
 ) ss.  
COUNTY OF \_\_\_\_\_ )

On this \_\_\_\_\_ day of \_\_\_\_\_, \_\_\_\_\_, before me appeared \_\_\_\_\_ to me personally known, who being by me was duly sworn, did say he/she is the \_\_\_\_\_ of \_\_\_\_\_, a \_\_\_\_\_; that the seal affixed to the foregoing instrument is the \_\_\_\_\_ seal of said \_\_\_\_\_; and said officer acknowledged said instrument to be the free act and deed of said \_\_\_\_\_.

\_\_\_\_\_  
Notary Public, State of \_\_\_\_\_

Name of Notary: \_\_\_\_\_

My commission expires: \_\_\_\_\_

**SURETY PLEASE INSERT YOUR APPLICABLE NOTARY SECTION**



**EXHIBIT A2**  
**LABOR AND MATERIAL PAYMENT BOND**  
**(11/17/98)**

**KNOW ALL BY THESE PRESENTS:**

That we, \_\_\_\_\_, whose mailing address is \_\_\_\_\_, as Contractor, (hereinafter called "Contractor"), is held and firmly bound unto the \_\_\_\_\_, its successors and assigns, as Obligee, (hereinafter called "Obligee"), in the amount of \_\_\_\_\_ **DOLLARS (\$\_\_\_\_\_)**, lawful money of the United States of America, for the payment of which to the said Obligee, well and truly to be made, Contractor binds itself, its heirs, executors, administrators, successors and assigns, firmly by these presents. Said amount is evidenced by:

- Legal tender;
- Share Certificate unconditionally assigned to or made payable at sight to \_\_\_\_\_;
- Certificate of Deposit, No. \_\_\_\_\_, dated \_\_\_\_\_, issued by \_\_\_\_\_, drawn on \_\_\_\_\_, a bank, savings institution, or credit union insured by the Federal Deposit Insurance Corporation or the National Credit Union Administration, payable at sight or unconditionally assigned to \_\_\_\_\_;
- Cashier's Check No. \_\_\_\_\_, dated \_\_\_\_\_, issued by \_\_\_\_\_, drawn on \_\_\_\_\_, a bank, savings institution, or credit union insured by the Federal Deposit Insurance Corporation or the National Credit Union Administration, payable at sight or unconditionally assigned to \_\_\_\_\_;
- Teller's Check No. \_\_\_\_\_, dated \_\_\_\_\_, issued by \_\_\_\_\_, drawn on \_\_\_\_\_, a bank, savings institution, or credit union insured by the Federal Deposit Insurance Corporation or the National Credit Union Administration, payable at sight or unconditionally assigned to \_\_\_\_\_;
- Treasurer's Check No. \_\_\_\_\_, dated \_\_\_\_\_, issued by \_\_\_\_\_;

\_\_\_\_\_, drawn on \_\_\_\_\_, a bank, savings institution, or credit union insured by the Federal Deposit Insurance Corporation or the National Credit Union Administration, payable at sight or unconditionally assigned to \_\_\_\_\_;

Official Check No. \_\_\_\_\_, dated \_\_\_\_\_, issued by \_\_\_\_\_, drawn on \_\_\_\_\_, a bank, savings institution, or credit union insured by the Federal Deposit Insurance Corporation or the National Credit Union Administration, payable at sight or unconditionally assigned to \_\_\_\_\_;

Certified Check No. \_\_\_\_\_, dated \_\_\_\_\_, issued by \_\_\_\_\_, drawn on \_\_\_\_\_, a bank, savings institution, or credit union insured by the Federal Deposit Insurance Corporation or the National Credit Union Administration, payable at sight or unconditionally assigned to \_\_\_\_\_.

**WHEREAS:**

The Contractor has by written agreement dated [Click here to enter a date.](#) entered into a contract with Obligee for the following PROJECT: [Click here to enter text.](#), (hereinafter called “Contract”), which Contract is incorporated herein by reference and made a part hereof.

**NOW, THEREFORE,**

The condition of this obligation is such that, if Contractor shall promptly and faithfully perform the Contract in accordance with, in all respects, the stipulations, agreements, covenants and conditions of the Contract as it now exists or may be modified according to its terms, free from all liens and claims and without further cost, expense or charge to the Obligee, its officers, agents, successors or assigns, free and harmless from all suits or actions of every nature and kind which may be brought for or on account of any injury or damage, direct or indirect, arising or growing out of the doing of said work or the repair or maintenance thereof or the manner of doing the same or the neglect of the Contractor or its agents or servants or the improper performance of the Contract by the Contractor or its agents or servants or from any other cause, and shall promptly pay all persons supplying labor and materials for the performance of the Contract, then this obligation shall be void; otherwise it shall be and remain in full force and effect.

**AND IT IS HEREBY STIPULATED AND AGREED** that suit on this bond may be

brought before a court of competent jurisdiction without a jury, and that the sum or sums specified in the said Contract as liquidated damages, if any, shall be forfeited to the Obligee, its successors or assigns, in the event of a breach of any, or all, or any part of, the covenants, agreements, conditions, or stipulations contained in the Contract or in this bond in accordance with the terms thereof.

**AND IT IS HEREBY STIPULATED AND AGREED** that this bond shall inure to the benefit of any and all persons entitled to file claims for labor performed or materials furnished in said work so as to give any and all such persons a right of action as contemplated by Sections 103D-324(d) and 103D-324(e), Hawai'i Revised Statutes.

The amount of this bond shall be reduced by and to the extent of any payment or payments made in good faith hereunder, inclusive of the payment of mechanics' liens which may be filed of record against the PROJECT, whether or not claim for the amount of such lien be presented under and against this bond.

Signed this \_\_\_\_ day of \_\_\_\_\_, \_\_\_\_\_.

(Seal)

\_\_\_\_\_  
Name of Contractor

\_\_\_\_\_  
Signature

\_\_\_\_\_  
Title

***ALL SIGNATURES MUST BE ACKNOWLEDGED BY A NOTARY PUBLIC***

STATE OF \_\_\_\_\_ )  
 ) ss.  
COUNTY OF \_\_\_\_\_ )

On this \_\_\_\_\_ day of \_\_\_\_\_, \_\_\_\_\_, before me appeared \_\_\_\_\_ to me personally known, who being by me was duly sworn, did say he/she is the \_\_\_\_\_ of \_\_\_\_\_, a \_\_\_\_\_; that the seal affixed to the foregoing instrument is the \_\_\_\_\_ seal of said \_\_\_\_\_; and said officer acknowledged said instrument to be the free act and deed of said \_\_\_\_\_.

\_\_\_\_\_  
Notary Public, State of \_\_\_\_\_

Name of Notary: \_\_\_\_\_

My commission expires: \_\_\_\_\_

**EXHIBIT B**  
***Placeholder***

**IFB Job No. 17-10**  
**Appendix B-GPCC**

**GENERAL PROVISIONS**  
**FOR**  
**CONSTRUCTION CONTRACTS**  
**OF THE**  
**DEPARTMENT OF WATER**  
**COUNTY OF KAUA‘I**  
**STATE OF HAWAI‘I**

**April 25, 2016**

**GENERAL PROVISIONS  
OF  
CONSTRUCTION CONTRACTS  
OF THE  
DEPARTMENT OF WATER  
COUNTY OF KAUA'I**

**April 25, 2016**

**Table of Contents**

SECTION 1 - DEFINITIONS . . . . .	8
1.1    ADDENDUM/ADDENDA . . . . .	8
1.2    BOARD . . . . .	8
1.3    BID . . . . .	8
1.4    BIDDER . . . . .	8
1.5    BID SECURITY . . . . .	8
1.6    CALENDAR DAY . . . . .	8
1.7    CHANGE ORDER . . . . .	8
1.8    CHIEF PROCUREMENT OFFICER . . . . .	8
1.9    CONTRACT . . . . .	8
1.10   CONTRACT TIME . . . . .	9
1.11   CONTRACTING OFFICER . . . . .	9
1.12   CONTRACTOR . . . . .	9
1.13   COST ANALYSIS . . . . .	9
1.14   COST DATA . . . . .	9
1.15   DAYS . . . . .	9
1.16   DEPARTMENT . . . . .	9
1.17   EXTENDED OVERHEAD . . . . .	9
1.18   FINAL PROPOSAL . . . . .	9
1.19   GUARANTEE . . . . .	9
1.20   HAR . . . . .	9
1.21   HAZARDOUS MATERIALS . . . . .	9
1.22   HAZARDOUS MATERIALS LAWS . . . . .	10
1.23   HRS . . . . .	10

1.24	INVITATION FOR BIDS or IFB .....	10
1.25	MANAGER .....	10
1.26	NOTICE TO PROCEED or NTP .....	10
1.27	OFFER .....	10
1.28	OFFEROR .....	10
1.29	OVERHEAD .....	10
1.30	PERSON .....	10
1.31	PRICE ANALYSIS .....	10
1.32	PRICE DATA .....	10
1.33	PROPOSAL .....	11
1.34	PROPOSER .....	11
1.35	REFERENCE SPECIFICATIONS .....	11
1.36	REQUEST FOR PROPOSALS or RFP .....	11
1.37	RESPONSIBLE OFFEROR .....	11
1.38	RESPONSIVE BIDDER or OFFEROR .....	11
1.39	SOLICITATION .....	11
1.40	STATE .....	11
1.41	WARRANTY .....	11
1.42	WORKING DAY .....	11
1.43	OTHER REFERENCES .....	12
SECTION 2 - BIDDING/PROPOSAL INSTRUCTIONS.....		14
2.1	DEPOSIT FOR PLANS, SPECIFICATIONS AND SPECIAL PROVISIONS .....	14
2.2	QUALIFICATIONS OF OFFERORS .....	14
2.3	CERTIFICATION OF HEALTH AND SAFETY .....	15
2.4	DETERMINATION OF RESPONSIBILITY .....	15
2.5	OFFER FORM .....	16
2.6	OFFER FORM, INTERPRETATION OF .....	16
2.7	PRICES TO COVER ENTIRE CONTRACT .....	17
2.8	COST AND PRICING DATA- PROPOSALS/Sole Source .....	17
2.9	BID SECURITY .....	18
2.10	PUBLIC OPENING OF BIDS .....	18
2.11	RECEIPT AND REGISTRATION OF PROPOSALS .....	19
2.12	EXAMINATION OF PLANS, SPECIFICATIONS, SPECIAL PROVISIONS AND SITE .....	19
2.13	TRADE NAMES AND ALTERNATIVES .....	20



2.14	PREFERENCES .....	20
2.15	MODIFICATION OR WITHDRAWAL OF OFFERS .....	20
2.16	LISTING OF JOINT CONTRACTORS AND SUBCONTRACTORS ..	21
2.17	BIDS, DISQUALIFICATION OF .....	22
2.18	PROPOSAL, DISQUALIFICATION OF .....	23
2.19	OFFEROR LIMITED ACCEPTANCE .....	23
2.20	MISTAKES IN BIDS .....	23
2.21	DISCUSSIONS WITH OFFERORS-REQUEST FOR PROPOSALS ..	25
SECTION 3	- AWARD AND EXECUTION OF CONTRACT.....	26
3.1	AWARD OF CONTRACT .....	26
3.2	CANCELLATION OF SOLICITATION OR AWARD .....	26
3.3	FUNDS, AVAILABILITY OF .....	26
3.4	ENTERING INTO CONTRACT .....	27
3.5	RESPONSIBILITY OF OFFERORS AND TAX CLEARANCE .....	27
3.6	PERFORMANCE AND PAYMENT BONDS .....	28
3.7	CAMPAIGN CONTRIBUTIONS BY STATE AND COUNTY CONTRACTORS .....	30
3.8	EMPLOYMENT OF STATE RESIDENTS ON CONSTRUCTION PROCUREMENT CONTRACTS .....	30
3.9	HAWAII PROCUREMENT LAW .....	30
SECTION 4	- LEGAL RELATIONS AND RESPONSIBILITY.....	31
4.1	AUTHORITY OF THE CONTRACTING OFFICER .....	31
4.2	INDEPENDENT CONTRACTOR .....	31
4.3	LAWS, REGULATIONS .....	32
4.4	PERMITS, LICENSES .....	33
4.5	NO PERSONAL LIABILITY .....	33
4.6	COORDINATION OF SPECIAL PROVISIONS, PLANS, SPECIFICATIONS, GENERAL PROVISIONS, WATER STANDARDS, AND OTHER PARTS OF THE CONTRACT DOCUMENTS .....	33
SECTION 5	- SCOPE OF CONTRACT.....	34
5.1	SCOPE OF CONTRACT .....	34
5.2	REQUESTS FOR INFORMATION .....	34
5.3	MODIFICATIONS TO THE WORK .....	35
5.4	PRICE ADJUSTMENT .....	37
5.5	DIFFERING SITE CONDITIONS .....	38

5.6	ASSIGNMENT, CHANGE OF NAME, NOVATION .....	38
5.7	VALUE ENGINEERING INCENTIVE .....	39
5.8	SUBSTITUTIONS .....	43
5.9	EXTRA WORK .....	44
5.10	PAYMENT FOR DELETED MATERIALS .....	44
SECTION 6	- PERFORMANCE OF CONTRACT .....	45
6.1	TIME .....	45
6.2	PERFORMANCE SCHEDULE .....	45
6.3	OWNER-CONTRACTOR MEETING, FIELD OFFICE AND FIELD TELEPHONE .....	46
6.4	DOCUMENTS TO BE KEPT ON SITE .....	47
6.5	ADDITIONAL PLANS AND SPECIFICATIONS TO BE FURNISHED BY THE CONTRACTING OFFICER .....	47
6.6	DRAWINGS TO BE FURNISHED BY CONTRACTOR .....	47
6.7	OMISSION IN CONTRACT .....	48
6.8	CONTRACTOR TO REPORT ERRORS OR DISCREPANCIES .....	48
6.9	CONTROL OF THE CONTRACT .....	48
6.10	PERSONAL SUPERVISION .....	51
6.11	CHARACTER OF WORKMEN, METHODS AND EQUIPMENT .....	51
6.12	WAGES AND HOURS .....	52
6.13	CONTRACTOR'S ADDRESS .....	53
6.14	OBSTRUCTIONS .....	53
6.15	SURVEYS AND CONSTRUCTION STAKES, LINES AND GRADES .....	54
6.16	SUBCONTRACTING .....	54
6.17	OTHER CONTRACTS .....	54
6.18	WATER REMOVAL .....	54
6.19	ELECTRICAL, TELECOMMUNICATION AND WATER SERVICE ..	54
6.20	UTILITIES UNDERGROUND .....	55
6.21	QUALITY OF MATERIALS AND EQUIPMENT .....	55
6.22	NATIONAL SANITATION FOUNDATION (NSF) APPROVALS ...	56
6.23	SAMPLES .....	56
6.24	PROTECTION OF PEDESTRIANS AND VEHICULAR TRAFFIC ..	56
6.25	ACCESS TO PROPERTY .....	58
6.26	PROJECT SIGN .....	58
6.27	PROJECT MAY BE PLACED IN SERVICE .....	58
6.28	PRECAUTIONS AND RESTORATION .....	59

6.29	MAINTENANCE OF SITE, CONTROL OF DUST, AND FINAL CLEANUP .....	66
6.30	RESPONSIBILITY OF THE CONTRACTOR PRIOR TO ACCEPTANCE .....	66
6.31	FINAL INSPECTION .....	67
6.32	FINAL COMPLETION AND FINAL ACCEPTANCE .....	67
6.33	GUARANTEE OF WORK .....	69
6.34	CLOSING CONTRACTS .....	69
SECTION 7	- PAYMENT.....	70
7.1	PAYMENT .....	70
7.2	VARIATIONS IN ESTIMATED QUANTITIES .....	70
7.3	QUANTITIES AND MEASUREMENTS .....	71
7.4	FORCE ACCOUNT .....	71
7.5	PAYMENTS DURING PERFORMANCE OF WORK .....	77
7.6	PAYMENT FOR DELIVERED MATERIALS .....	77
7.7	FINAL INSPECTION - FINAL PAYMENT .....	78
7.8	PROMPT PAYMENT BY CONTRACTORS TO SUBCONTRACTORS ..	78
SECTION 8	- REMEDIES.....	82
8.1	DISPUTES .....	82
8.2	CLAIMS BASED ON ORAL DIRECTIVES .....	82
8.3	DEFAULT, DELAY AND TIME EXTENSIONS .....	83
8.4	SUSPENSION OF WORK .....	85
8.5	TERMINATION OF CONTRACT - WORK MAY BE TAKEN OVER BY DEPARTMENT .....	86
8.6	TERMINATION FOR CONVENIENCE .....	88
8.7	COSTS OF COMPLETING CONTRACT .....	90
8.8	DAMAGES FOR DELAY .....	90
8.9	DAMAGES FOR EXTRA EXPENSES IMPOSED ON DEPARTMENT .	90
8.10	DEFECTIVE WORK .....	90
8.11	UNAUTHORIZED PERFORMANCE .....	90
8.12	AUTHORITY TO WITHHOLD MONEY DUE OR PAYABLE .....	91
8.13	SPECIAL EMERGENCY TERMINATION .....	91
8.14	REMEDIES NOT EXCLUSIVE .....	92
8.15	REMEDIES .....	92
EXHIBIT A	- SURETY [BID][PROPOSAL] BOND.....	93

EXHIBIT B - PERFORMANCE BOND (SURETY).....	94
EXHIBIT C - PERFORMANCE BOND.....	95
EXHIBIT D - LABOR AND MATERIAL PAYMENT BOND (SURETY).....	97
EXHIBIT E - LABOR AND MATERIAL PAYMENT BOND.....	98
EXHIBIT F - PERFORMANCE BOND (SURETY) FOR SUPPLEMENTAL AGREEMENT FOR GOODS AND SERVICES.....	100
EXHIBIT G- PERFORMANCE BOND FOR SUPPLEMENTAL AGREEMENT FOR GOODS AND SERVICES.....	101
EXHIBIT H - CONTRACTOR ACKNOWLEDGMENT.....	103
EXHIBIT I - SURETY ACKNOWLEDGMENT.....	104
EXHIBIT J - SAMPLE CONTRACT.....	105
EXHIBIT K - CONTRACT CHANGE ORDER.....	127
EXHIBIT L - CONTRACT MODIFICATION FORM.....	128
EXHIBIT M - AS BUILT INFORMATION REQUIRED.....	129
EXHIBIT N - BMP INSPECTION FORM.....	131
EXHIBIT O - EMPLOYMENT OF STATE RESIDENTS COMPLIANCE FORM.....	136
EXHIBIT P - REQUEST FOR INFORMATION (RFI) FORM.....	137

**DEPARTMENT OF WATER  
COUNTY OF KAUA‘I  
STATE OF HAWAI‘I**

**GENERAL PROVISIONS OF CONSTRUCTION CONTRACTS  
OF THE DEPARTMENT OF WATER, COUNTY OF KAUA‘I**

**SECTION 1 - DEFINITIONS**

When used in these provisions or elsewhere in the contract, the following terms, or pronouns used in place of them, shall have the meaning ascribed to them in this section, unless it is apparent from the context that a different meaning is intended:

- 1.1 ADDENDUM/ADDENDA** means a written document issued during the solicitation period involving changes to the solicitation documents which shall be considered and made a part of the solicitation documents and resulting contract [HAR 3-122-16.06].
- 1.2 BOARD** means the Board of Water Supply, County of Kaua‘i and the Department of Water County of Kaua‘i, its officers and employees.
- 1.3 BID** is as described in Hawai‘i Revised Statutes 103D-302.
- 1.4 BIDDER** means person or entity that has submitted a bid in response to the Department of Water, County of Kaua‘i’s Invitation for Bids.
- 1.5 BID SECURITY** means security provided at the time an offer is submitted.
- 1.6 CALENDAR DAY** means days shown on the calendar beginning at midnight and ending at midnight of the following day. If no designation of calendar or working day is made, “Day” shall mean calendar day.
- 1.7 CHANGE ORDER** means an amendment or modification of the work within the scope of the Contract, by the Contracting Officer or his/her authorized designee, directing the Contractor to make changes with or without the consent of the Contractor. [HRS 103D-104] [HAR 3-125-2][HAR 3-125-4]
- 1.8 CHIEF PROCUREMENT OFFICER** means the Manager and Chief Engineer of the Department.
- 1.9 CONTRACT** means the written agreement covering the construction of the project by the contractor, including the furnishing of labor, materials and equipment in connection therewith. It shall include these provisions, the contract and/or agreement, the notice to the bidders or proposers, the offer, the award, the special provisions, the plans, the specifications, the bond, any addendum and any written order. It shall also include all amendments to the contract by supplemental agreement thereto in writing.

**1.10 CONTRACT TIME** means the number of calendar days provided in the contract for completion of the contract, exclusive of authorized time extensions. The contract time will be indicated in the bid or proposal document and contract.

If the contract requires completion by a certain date, the contractor shall complete the work by that date.

**1.11 CONTRACTING OFFICER** means the Procurement Officer or Contract Administrator, or Construction Project Management Officer of the Department of Water, County of Kaua‘i or his or her duly authorized representative.

**1.12 CONTRACTOR** means the person who has entered into the contract with the Department and further defined by Section 444-1(2), HRS, as amended.

**1.13 COST ANALYSIS** means the evaluation of cost data for the purpose of arriving at costs actually incurred or estimates of costs to be incurred, prices to be paid, and costs to be reimbursed. [HAR 3-120-2]

**1.14 COST DATA** means information concerning the actual or estimated cost of labor, material, overhead, and other cost elements which have been actually incurred or which are expected to be incurred by the contractor in performing the contract. [HAR 3-120-2]

**1.15 DAYS** means consecutive calendar days unless otherwise specified. [HAR 3-120-2]

**1.16 DEPARTMENT** means the Department of Water, County of Kaua‘i, its officers and employees.

**1.17 EXTENDED OVERHEAD** includes project field office rental, salaries of field office and management staff, field office staff vehicles, field office utilities and telephone, and field office consumables, project fees, project bonding, project insurances and all taxes including general excise tax.

**1.18 FINAL PROPOSAL** means the final mutually-agreed terms of the proposal submitted by the awarded Offeror in response to the County’s RFP or the Best and Final Offer accepted by the County in accordance with HAR §3-122-53 and 3-122-54.

**1.19 GUARANTEE** means a formal assurance of the quality or of the length of use to be expected from a product offered or constructed.

**1.20 HAR** means the Hawai‘i Administrative Rules of the State of Hawai‘i, as amended.

**1.21 HAZARDOUS MATERIALS** mean and include any and all radioactive materials, asbestos, organic compounds known as polychlorinated biphenyls, chemicals known to cause cancer or reproductive toxicity, hazardous wastes, toxic substances, and any and all other substances or materials defined as “hazardous materials,” “extremely hazardous materials,” “hazardous wastes” or “toxic substances” under or for the purposes of hazardous materials laws.

- 1.22 HAZARDOUS MATERIALS LAWS** mean and include all federal, state or local laws, ordinances, rules, regulations or codes, now or hereafter in effect, relating to environmental conditions, human health or industrial hygiene, including but not limited to the Comprehensive Environmental Response, Compensation and Liability Act of 1980, as amended, 42 U.S.C. section 9601, et seq., the Resource Conservation and Recovery Act, 42, U.S.C. section 6901, et seq., the Hazardous Materials Transportation Act, 42 U.S.C. section 1801, et seq., the Clean Water Act, 33 U.S.C. section 1251 et seq., the Clean Air Act, 42 U.S.C. 7401 et seq., the Toxic Substances Control Act, 15 U.S.C. section 2601 - 2629, the Safe Drinking Water Act, 42, U.S.C. sections 300f - 300j, HRS Chapter 128D, Environmental Response Law, HRS Chapter 342B, Air Pollution Control, HRS Chapter 342D, Water Pollution, HRS Chapter 342H, Solid Waste Pollution, HRS Chapter 342J, Hazardous Waste, HRS Chapter 342L, Underground Storage Tanks, Chapter 342P, Asbestos, and any similar state or local laws or ordinances and the regulations now in effect or hereafter adopted, published or promulgated thereto.
- 1.23 HRS** means the Hawai‘i Revised Statutes of the State of Hawai‘i, as amended.
- 1.24 INVITATION FOR BIDS or IFB** means all documents, whether attached or incorporated by reference, utilized for soliciting bids under the competitive sealed bidding source selection method. [HAR 3-120-2]
- 1.25 MANAGER** means the Manager and Chief Engineer of the Department or his or her duly authorized representative.
- 1.26 NOTICE TO PROCEED or NTP** means the document issued to the Contractor designating the official commencement date of the performance under the Contract.
- 1.27 OFFER** refers to bidders and/or proposers.
- 1.28 OFFEROR** refers to bidders and/or proposers.
- 1.29 OVERHEAD** includes office expense, staff salaries, travel expenses, legal expenses, fees, insurances, bonding and all taxes including general excise tax.
- 1.30 PERSON** means an individual, a partnership, joint venture, a corporation, whichever is applicable.
- 1.31 PRICE ANALYSIS** means the evaluation of price data, without analysis of the separate cost components and profit as in cost analysis, which may assist in arriving at prices to be paid and costs to be reimbursed. [HAR 3-120-2]
- 1.32 PRICE DATA** means factual information concerning prices, including profit, for goods, services, or construction substantially similar to those being procured. In this definition, “prices” refers to offered or proposed selling prices, historical selling prices, and current selling prices of such items. This definition refers to data relevant to both the general contractor and subcontract prices. [HAR-3-120-2]

**1.33 PROPOSAL** means the executed document submitted by an Offeror in response to a Request for Proposals. [HAR 3-120-2].

**1.34 PROPOSER** means person or entity that has submitted an offer in response to the Department of Water, County of Kaua‘i’s Invitation for Bids or Request for Proposal.

**1.35 REFERENCE SPECIFICATIONS** means the most recently adopted and published edition of such specifications referred to on the date of the notice to bidders or proposers is contemplated, unless otherwise specified.

References are on file at the Department of Water for review by prospective bidders or proposers. Upon request, copies of a section or sections of the references will be made available pursuant to the Kaua‘i County Code on reproducible charges for public records.

**1.36 REQUEST FOR PROPOSALS or RFP** means all documents, whether attached or incorporated by reference, utilized for soliciting proposals under the competitive sealed proposal source selection method. [HAR 3-120-2]

**1.37 RESPONSIBLE OFFEROR** means a person who has the capability in all respects to perform fully the Contract requirements, and the integrity and reliability which will assure good faith performance. [HRS 103D-104]

**1.38 RESPONSIVE BIDDER or OFFEROR** means a person who has submitted an offer which conforms in all material respects to the IFB or RFP. [HAR 3-120-2]

**1.39 SOLICITATION** means an invitation for bids, request for proposals, or a request for quotations, or any other document issued by the County for the purpose of soliciting bids or proposals to perform a County contract. [HAR 3-120-2]

**1.40 STATE** means the State of Hawai‘i.

**1.41 WARRANTY** means a written statement that promises the good condition of a product and states that the maker is responsible for repairing or replacing the product for a certain period of time after its purchase.

**1.42 WORKING DAY** means a calendar day, exclusive of: (1) Saturdays, Sundays and State recognized legal holidays, (2) days during which the Contractors required to suspend construction operations, and (3) days on which weather and other conditions not under the control of the contractor will not permit construction operations to proceed for at least 5 hours of the day. The contractor shall perform the controlling item or items of work.



## 1.43 OTHER REFERENCES

### A. Abbreviations.

The following abbreviations shall refer to the technical society, organization, body, code, rules or standard, listed opposite each abbreviation:

AASHTO	American Association of State Highway and Transportation Officials
ACI	American Concrete Institute
AGC	Associated General Contractors of America
AIA	American Institute of Architects
AISC	American Institute of Steel Construction
AISI	American Iron and Steel Institute
ANSI	American National Standards Institute
ASCE	American Society of Civil Engineers
ASTM	American Society for Testing and Materials
AWWA	American Water Works Association
AWRA	American Water Resources Association
HRS	Hawai'i Revised Statutes
HAR	Hawai'i Administrative Rules
IANPO	International Association of Plumbing & Mechanical Officials
MUTCD	Manual on Uniform Traffic Control Devices
NEC	National Electric Code
NEMA	National Electric Manufacturers Association
NSF	National Sanitation Foundation
UL	Underwriter's Laboratory
USGS	U.S. Geological Survey

B. **Standard Detail Drawings, Water Standards, Specifications and Special Provisions.**

When reference is made to standard detail drawings, Water Standards, specifications or special provisions, such referral shall be to the standard detail drawings, Water Standards, specifications or special provisions of the Department of Water, as amended.

Water Standards shall mean the “Water System Standards, State of Hawai‘i, 2002”, as amended, as adopted by Department of Water, County of Kaua‘i; Board of Water Supply, City and County of Honolulu; Department of Water Supply, County of Maui; and Department of Water Supply, County of Hawai‘i.

## **SECTION 2 – BIDDING/PROPOSAL INSTRUCTIONS**

### **2.1 DEPOSIT FOR PLANS, SPECIFICATIONS AND SPECIAL PROVISIONS**

Plans, Specifications and Special Provisions of the contract may be obtained from the Department of Water, Līhu‘e, Kaua‘i, upon deposit of the amount specified in the Notice to Bidders or Notice of the Request for Proposals.

Unless otherwise stated in the Notice to Bidders or the Notice of the Request for Proposals, the deposit for the plans, specifications and special provisions will be refunded upon their return in good condition to the Department of Water within thirty (30) calendar days after the day on which bids or proposals have been opened.

Deposits shall be forfeited if the plans, specifications and special provisions are not returned within the specified time or in good condition. The plans and specifications shall not, under any circumstances be disassembled. Should the Department discover any evidence of disassembling upon the return of the plans and specifications, the deposit on said plans and specifications shall be forfeited to the Department.

The sample form of the bid or proposal shall not be detached from the Special Provisions.

### **2.2 QUALIFICATIONS OF OFFERORS**

All offerors shall be contractors licensed in accordance with Chapter 444, Hawai‘i Revised Statutes, as amended, to perform the work under the contract.

No contract will be awarded to any person who has been suspended under and as provided in, the provisions of Chapter 104, Hawai‘i Revised Statutes, Chapter 126, Subtitle 11, Title 3, Hawai‘i Administrative Rules and HRS 103D-702, or to any firm in which such suspended person has an interest.

Qualifications of Offerors. Prospective offerors must be capable of performing the work for which solicitations are being called. Each prospective offeror must file a written notice of intention to bid or propose which shall be received not less than ten (10) calendar days prior to the day designated for opening of bids or proposals. If the tenth calendar day prior to the day designated for opening of bids or proposals is a Saturday, Sunday, or legal State holiday, the written notice must be received by the Manager no later than 4:30 p.m. on the working day immediately before said Saturday, Sunday, or legal State holiday.

Prospective offerors shall, upon request, prove to the Manager his or her responsibility by showing, among other things, his or her experience in handling the class of service, article, material or machinery to be furnished and delivered, and that he or she possesses or is in a position financially and otherwise to secure and pay for said service, article, machinery or material by submitting answers under oath to all questions contained in the “Standard Qualification Questionnaire for Prospective Offerors on Department of Water Contracts” as

required by Section 103D-310, Hawai'i Revised Statutes, as amended, to the Department not less than ten (10) calendar days prior to the day fixed for the opening of the bids or proposals.

All information contained in answers to the questionnaire shall be and remain confidential. Questionnaires so submitted shall be returned to such offerors after having served their purpose. (Auth: 3-122-108 HAR)

## **2.3 CERTIFICATION OF HEALTH AND SAFETY**

a) The Contractor shall give notices and comply with applicable laws, ordinances, rules, regulations and lawful orders of public authorities bearing on safety of persons or property or their protection from damage, injury or loss. The cost of Safety and Health shall not be paid for directly but shall be considered incidental and included in the prices bid for the various items of work.

b) Safety and Health Certificate of Compliance. A certificate of compliance shall be submitted with each offer certifying that, if awarded the contract, the offeror will comply with Section 396-18, HRS, relating to safety and health programs for County construction projects, where the offer amount is in excess of \$100,000. The certificate of compliance shall be submitted with the offer. Failure to submit the required certification shall be grounds for disqualification of the offer.

## **2.4 DETERMINATION OF RESPONSIBILITY**

The Contracting Officer shall determine, on the basis of available information collected, the responsibility or nonresponsibility of a prospective offeror.

If the Contracting Officer requires additional information, the prospective offeror shall promptly supply such information within two (2) working days from the date requested. Failure to supply the requested information within the above stated time may be considered unreasonable and may be grounds for a determination of nonresponsibility.

Notwithstanding the paragraph immediately above, the Contracting Officer shall not be precluded from requesting additional information.

Upon determination that a prospective offeror is not fully qualified to perform the work, the shall afford the prospective offeror an opportunity to be heard. Upon conclusion of the hearing and if still of the opinion that the offeror is not fully qualified to perform the work, the Contracting Officer shall refuse to receive or consider any offer offered by the prospective offeror.

A written determination of nonresponsibility of an offeror shall be made by the Contracting Officer. The prospective offeror shall be immediately notified of the determination. The decision of the Contracting Officer shall be final unless the offeror applies for administrative review pursuant to Chapter 126, Subtitle 11, Title 3, HAR. (Auth: HRS: 103D-310) (Imp: HRS 103D-310) (Auth: 3-122-108, HAR)

## **2.5 OFFER FORM**

Offers must be on an offer form provided for such purpose by the Department. Offers must be signed in ink by the person or persons duly authorized to sign offers in the space provided for signature on the offer forms. In the case of a domestic corporation, the title or titles of the person or persons signing must be stated. Where the offeror is an association or group, the title or titles of the person or persons signing must be stated and an affidavit of the association or group must be attached which acknowledges the authority of the signer or signers to sign offers and all other necessary documents in connection therewith for the association or group.

Offers shall be sealed and enclosed in envelopes showing the name of the project. Unless otherwise specified, offerors shall submit offers on all items shown on the offer form. Offers shall be typewritten or printed in ink. Errors may be erased or crossed out, and corrections typewritten or printed in ink must be initialed in ink by the persons or persons signing the bids.

The offers shall be deposited at the Department, not later than the time specified for such opening. Offers received after the specified time for opening in the notice, as evidenced by the time stamp of the Department, shall be considered late and rejected; however, a late offer shall not be considered late if received before contract award and would have been timely but for the action or inaction of personnel within the Department. A late offer that will not be considered for award shall be returned to the offeror unopened as soon as practicable and accompanied by a letter from the Contracting Officer stating the reason for its return. (Auth: 3-122-16.08(a)(b) HAR)

Offers transmitted via facsimile are unacceptable and will be rejected and returned to the offeror.

## **2.6 OFFER FORM, INTERPRETATION OF**

The offer form does not necessarily outline all of the work involved in the performance of the contract, but is merely a list of items upon which the computation of compensation is to be based. The offer form contains all items to be used in such computation, and the compensation computed therefrom shall be full compensation for the performance of the contract.

If it should appear to a prospective offeror that the performance of the work under the contract or any of the matters relative thereto, is not sufficiently described or explained in the offer form, or that any discrepancy exists between different parts thereof, or that the full intent of the form is not clear, then the offeror shall submit a written request for clarification to the Contracting Officer no later than ten (10) calendar days before the day fixed for the opening of offers, as evidenced by the time-stamp of the Department. The offeror submitting the inquiry shall be responsible for its delivery.

If additional information is deemed necessary, such information will be issued in an

addendum by the Contracting Officer. The addendum will be mailed, facsimile, or delivered to all persons who have obtained the special provisions, plans, and specifications of the contract. All addenda issued shall be a part of the contract. (Auth: 3-122-16.06 HAR)

If during discussions during the RFP process, there is a need for any substantial clarification or change in the RFP, the RFP shall be amended by an addendum to incorporate the clarification or change. Addenda to the RFP shall be distributed only to priority-listed Offerors and shall be a part of the contract.

No oral interpretation, instruction or information concerning the contract given by any officer, employee or agent of the Department shall be binding on the Department. (HAR 3-122-16.06)

## **2.7 PRICES TO COVER ENTIRE CONTRACT**

Offerors shall include in their offered prices the entire cost of the performance of the contract, and it is understood and agreed that there is included in each lump sum or unit price, the entire cost of all items incidental to the performance of the contract, covered by such lump sum or unit price offer. Offerors in figuring the offer price shall take into consideration the cost of all freight and delivery charges, marine insurance and taxes; and shall include the cost of furnishing and installing all equipment as called for in the specifications including warranty repairs of the complete unit. Whenever installation is specified, installation shall include all necessary labor, materials and other incidentals required to make a complete operative unit. When an offeror is in doubt as to the proper item to which the anticipated cost of any incidental item is to be allocated, he or she shall include such cost in the lump sum or unit price for the items that he or she deems most appropriate.

It is understood and agreed that whenever unit price(s) is/are called for on the provided page(s), all offerors must indicate their unit price(s) on the blank space(s) provided thereon. Failure to comply will be grounds for rejection. (Auth: 3-122-97 HAR).

Prices shall remain valid for ninety (90) calendar days after the established bid submission deadline.

## **2.8 COST AND PRICING DATA- PROPOSALS/Sole Source**

a) A contractor, except as provided in subsection c herein, shall submit cost or pricing data and shall certify that, to the best of the contractor's knowledge and belief, the cost or pricing data submitted is accurate, complete and current as of a mutually determined specified date prior to the date of:

1) The pricing of any contract awarded by competitive sealed proposals or pursuant to the sole source procurement authority, where the total contract amount is expected to exceed an amount established in HAR; or

b) If this provision is applicable then the price to the Department, including profit or fee, shall be adjusted to exclude any significant sums by which the Department finds that the

price was increased because the contractor furnished cost or pricing data that was inaccurate, incomplete, or not current as of the date agreed upon between the parties.

c) This section shall not apply to contracts where:

- 1) The contract price is based on adequate price competition
- 2) The contract price is based on established catalog prices or market prices;
- 3) The contract prices are set by law or rule;
- 4) It is determined in writing that the requirements of this section may be waived.  
(HRS 103D-312)

## **2.9 BID SECURITY**

Bid security shall be required for construction contracts procured by way of invitation for bid or request for proposals, of \$25,000 or more or for construction contracts for less than \$25,000 when required by the Contracting Officer. Bid security shall be in an amount equal to at least five percent (5%) of the amount of the base bid and additive alternates or in an amount required by the terms of the federal funding.

Acceptable bid security, shall be limited to:

1. Surety bond underwritten by a company licensed to issue bonds in the State of Hawai‘i;
2. Legal tender of the United States of America; or
3. A certificate of deposit; share certificate; or cashier’s, treasurer’s, teller’s, or official check drawn by, or a certified check accepted by a bank, savings institution, or credit union insured by the United States Federal Deposit Insurance Corporation or the National Credit Union Administration and payable at sight or unconditionally assigned to the Department.
  - a. These instruments may be utilized only to a maximum of \$100,000.
  - b. If the required security or bond amount totals over \$100,000, more than one instrument not exceeding \$100,000 each and issued by different financial institutions which meet the requirements of this subsection shall be accepted. (HAR 3-122-222)

All documentation provided to the Department agency shall contain the original signatures signed in ink. (HAR 2-122-222, 3-122-223). Unless it is determined that a failure to provide bid security is non-substantial, all bids required to be accompanied by bid security that fail to have the appropriate bid security shall be rejected. Bid deposit form is attached hereto as Exhibit A. (Auth. 3-122-222; 3-122-223 HAR).

## **2.10 PUBLIC OPENING OF BIDS**

Bids shall be opened and read publicly, at the time and place indicated in the Notice to Bidders. Bidders or their authorized agents may be present.

Bidders may request for nondisclosure of trade secrets and other proprietary data in writing. Confidential material shall be readily separable from the bid in order to facilitate public inspection of the nonconfidential portion of the bid: The Contracting Officer shall determine the validity of the request for nondisclosure. (Auth: 3-122-30, HAR)

## **2.11 RECEIPT AND REGISTRATION OF PROPOSALS**

Proposals and modifications shall be time-stamped upon receipt and held in a secure place by the procurement officer until the established due date. Proposals and modifications shall not be opened publicly, but shall be opened in the presence of two (2) or more County officials. Proposals and modifications shall be shown only to members of the evaluation committee and Department personnel or their designees having legitimate interest in them. (Auth: 3-122-51, HAR).

## **2.12 EXAMINATION OF PLANS, SPECIFICATIONS, SPECIAL PROVISIONS AND SITE**

Offerors shall examine the site of the proposed work and the provisions of the contract, including but not limited to the proposal, addenda, bond forms, bid form, special provisions, plans and specifications before submitting a bid or proposal. The submission of a bid or proposal shall be considered conclusive evidence that the offeror has made such examination; knows the surface and subsurface conditions of the site, the character, quality and quantities of labor, materials and equipment and other requirements necessary under the contract; and agrees to all and every item, covenant, condition and provision of the contract.

Where investigation of subsurface conditions has been made by the Department, in respect to foundation or other design, offerors may inspect the records of the Department as to such investigation and examine any sample that may be available.

Investigations of subsurface conditions are made for the purpose of design, and the Department assumes no responsibility whatsoever as to the sufficiency or accuracy of borings or of the log of test borings or reports or other investigations, or of the interpretation thereof, and there is no guaranty, either expressed or implied, that the conditions indicated are representative of those to be encountered during the performance of the contract, or any part thereof, or that the bidder or proposer may not encounter unforeseen subsurface conditions.

Making information concerning subsurface conditions available to bidders or proposers is not to be construed in any way as a waiver of the provisions of the first paragraph of this subsection and bidders or proposers must satisfy themselves through their own investigation as to conditions to be encountered.

Records of such investigations as may have been made by the Department may be inspected at the Department of Water.



## 2.13 TRADE NAMES AND ALTERNATIVES

**Before Bid or Proposal Opening.** When the plans or specifications specify one (1) or more manufacturers' brand names or makes of materials, devices or equipment or system indicating a quality style, appearance or performance, such specifications shall be deemed to be used for the purpose of establishing a standard of quality and to facilitate the description of the material or process desired and shall be deemed to be followed by the words "or equal". The offeror shall base his or her offer on either one of the specified brands or an alternate brand which the Contracting Officer has approved to be equal or better by way of addendum to such specification and/or plans. If an offeror intends to base his or her offer on an alternate brand, unless otherwise specified, he or she shall submit a written request to do so, to the Contracting Officer at the earliest date possible, but no later than ten (10) calendar days as evidenced by the time-stamp of the Department, before the day fixed for the opening of offers.

The burden of proof as to the comparative quality and suitability of alternative equipment, articles or materials shall be upon the offeror and he or she shall furnish, at his or her own expense, such information relating thereto as may be required by the Contracting Officer. The Offeror shall issue a statement of variances that lists all features of the proposed substitution which differ from the plans, specifications and/or product(s) specified and must certify that the substitution has no other variant features. Should an unlisted variance be discovered after installation of the product, the remedy shall be immediate replacement with a specified product at no cost to the Department. The Contracting Officer shall be the sole judge as to the comparative quality and suitability of alternative equipment; articles or materials and his or her decisions shall be final.

Any offeror, who bases his or her offer on an alternate brand which has been approved by the Contracting Officer, shall include in his or her offer the additional cost required for all modifications in the contract and the cost of all additional diagrams and drawings required to accommodate the alternate equipment. The modifications referred to include the changes in design that may be required for such work as, but not limited to, electrical, plumbing and other waterworks facilities.

## 2.14 PREFERENCES

- A. All offers shall comply with the preferences, as applicable, outlined in HAR 3-124, including but not limited to Hawai'i Products Preference and Recycled Products Preference, and the Apprenticeship Program Preference laid out in Section 103-55.6, Hawai'i Revised Statutes, as enacted by S.B. 19, Act 17, SLH 2009, and the State of Hawai'i Comptroller's Memorandum 2011-25 as amended, which provides for a Hawai'i Apprenticeship Preference for public works construction projects with estimated values of \$250,000 or greater.
- B. This subsection shall not apply whenever its application will disqualify the Department from receiving Federal funds or aid.

## 2.15 MODIFICATION OR WITHDRAWAL OF OFFERS

- A. **Pre-opening Modification or Withdrawal of Offers.**

Offers may be modified or withdrawn at any time prior to the time fixed in the notice to offerors for opening of offers, or if applicable, prior to the date at which the Best and Final Offer is due.

An offeror may withdraw his or her offer by: (1) a written notice received by the Department, or (2) a notice sent by facsimile machine to the Department.

A offeror may modify his or her offer by: (1) a written notice accompanying the actual modification received by the Department, stating that a modification to the offer is submitted, or (2) a written notice accompanying the actual modification by facsimile to the Department, provided the offeror submits the actual written notice and modification within two (2) working days of receipt of the facsimile. (Auth: 3-122-16.07, HAR)

**B. Late Offers, Late Withdrawals and Late Modifications.**

Any notice of withdrawal or notice of modification of any offer with the actual modification received by the Department after the time and date set for receipt and opening is late and shall not be considered for award except when received before contract award and would have been timely but for the action or inaction of personnel within the Department. (Auth: 3-122-16.08, HAR)

- C. After the established due date for offers, an offer may be withdrawn only if the Department fails to award the contract within ninety (90) calendar days after the established due date for offers.

## **2.16 LISTING OF JOINT CONTRACTORS AND SUBCONTRACTORS**

Pursuant to Section 103D-302, HRS, as amended, all offerors shall state in their bids the name of each person or firm that will be engaged as a joint venture, partner, or subcontractor and the nature and scope of the work to be performed by each such joint venture, partner, or subcontractor. All bids which do not comply with this requirement shall be rejected pursuant to Sec. 103D-302(b), H.R.S.

### **MANDATORY LICENSING REQUIREMENT:**

“A” general engineering contractors and “B” general building contractors are reminded that due to the Hawai‘i Supreme Court’s January 28, 2002 decision in Okada Trucking Co., Ltd. v. Board of Water Supply, et al., 97 Haw. 450 (2002), they are prohibited from undertaking any work, solely or as part of a larger project, which would require the general contractor to act as a specialty contractor in any area in which the general contractor has no license. Although the “A” and “B” contractor may still bid on and act as the “prime” contractor on an “A” or “B” project (See, HRS § 444-7 for the definitions of an “A” or “B” project.), respectively, the “A” and “B” contractor may only perform work in the areas in which they have the appropriate contractor’s license (An “A” or “B” contractor obtains “C” specialty contractor’s license either on its own, or automatically under HAR § 16-77-32.). The remaining work must be subcontracted out to appropriately licensed entities. **It is the sole responsibility of the contractor to review the requirements of this project and determine the appropriate licenses that are required to complete the project.**

Although the bid documents may provide a list of the contractor licenses that the County anticipates are required to complete this particular project, this list is not all inclusive and additional licenses may be required. If a specialty license/class is required to complete the scope of work and the contractor does not list said license(s), the contractor may have their bid rejected as non-responsive. Examples of specialty license/classes that should be listed are licensed surveyor, licensed geotechnical engineer, licensed structural engineer, licensed civil engineer, specialty inspectors, archaeologist, and cultural monitor.

The contractor shall be responsible under the contract for acts and omissions of his or her subcontractors, suppliers and persons either directly or indirectly employed by them, as fully as he or she is for acts and omissions of his or her own employees. Nothing in the contract shall create any contractual relation between any subcontractor, partner, joint venture or supplier and the Department or any obligation on the part of the Department to pay or cause to be paid any money to any subcontractor or supplier.

## **2.17 BIDS, DISQUALIFICATION OF**

- A. Bids which are conditional or not in compliance with the bidding instructions may be rejected.

**Multiple or alternate offers.** Unless specifically provided for in the solicitation, multiple or alternate offers shall not be accepted and all such offers shall be rejected (HAR 3-122-4)

- B. Bids may be rejected for the following reasons including, but not limited to:

1. Bidder determined to be “nonresponsive,” pursuant to Subchapter 13, HAR. (Auth: 3-122-97, HAR); or
2. The bid is “not responsive”. Bid does not conform in all material respects to the invitation for bids by reason of its failure to meet the requirements of the specifications or permissible alternates or other acceptability criteria set forth in the invitation for bid pursuant to section 3-122-33 HAR. (Auth: 3-122-97, HAR); or
3. The good, service, or construction item offered in the bid is unacceptable because of its failure to meet the requirements of the specifications or permissible alternatives or other acceptability criteria set forth in the invitation for bids under the provisions of Sec. 3-122-33, HAR. (Auth: 3-122-97, HAR)
4. Bid submitted by any person submitting more than one (1) bid under the same or different names, under his or her own name, or through his or her agents, or through joint ventures, partnerships or corporations in which he has more than twenty-five percent (25%) interest in each of them, or through any contractor thereof.

If there is any evidence indicating that two (2) or more bidders are in collusion to restrict competitive bidding, the bids of all such bidders shall be

rejected and such evidence may be a cause for the disqualification of the participants in any future proposal involving any contract with the Department.

5. Any offer which is conditioned upon receiving award of both the particular contract being solicited and another Department contract. (Auth: 3-122-6, HAR)

## **2.18 PROPOSAL, DISQUALIFICATION OF**

- A. A proposal may be accepted with modification or correction unless the solicitation states otherwise.
  1. This allowance must be considered in determining whether reasons exist for rejecting all or any part of a proposal.
  2. A proposal may be rejected for reasons including but not limited to:
    - a. The offeror is nonresponsible pursuant to Subchapter 13, HAR. (Auth.: 3-122-97)
    - b. The proposal, after any opportunity has passed for modification or clarification, fails to meet the announced requirements of the agency in some material respect; or
    - c. The proposed price is clearly unreasonable.

## **2.19 OFFEROR LIMITED ACCEPTANCE**

- A. An offeror may not limit acceptance to the entire bid or proposal offering, unless allowed by the solicitation:
  1. If the acceptance of an offer is so limited by the offeror but not allowed, the offer will be determined to be not acceptable and rejected.
  2. If the acceptance of an offer is so limited by the offeror and allowed, the purchasing agency shall not reject part of the offer and award on the remainder. (3-122-97 HAR)

## **2.20 MISTAKES IN BIDS**

- A. A bidder may correct, waive or withdraw an obvious mistake in his or her bid to the extent it is not contrary to the best interest of the Department or to the fair treatment of other bidders.
- B. Before Bid Opening. A bidder may remedy a mistake in a bid discovered before the time fixed in the notice to bidders for opening of bids by withdrawing or correcting the bid as provided in subsection 2.15 of these General Provisions.

C. After Bid Opening But Prior to Award.

1. A mistake in a bid discovered after bid opening but prior to award may be corrected or waived if:
  - a. The mistake is attributable to an arithmetical error, the Contracting Officer shall so correct the mistake. In case of error in extension of bid price, unit price shall govern.
  - b. The mistake is a minor informality which shall not affect price, quantity, quality, delivery, or contractual conditions, the Contracting Officer may waive such informalities or allow the bidder to request correction by submitting proof of evidentiary value which demonstrates that a mistake was made. The Contracting Officer shall prepare a written approval or denial in response to this request. Examples of such mistakes include:
    - (1) Typographical errors;
    - (2) Failure to return the number of signed bids required by the invitation for bids;
    - (3) Failure to acknowledge receipt of an amendment to the Invitation for Bids, but only if:
      - (a) It is clear from the bid that the bidder received the amendment and intended to be bound by its terms; or
      - (b) The amendment involved had a negligible effect on price, quantity, quality or delivery;
    - (4) Arithmetical errors;
    - (5) Transposition errors;
    - (6) Failure of a bidder to sign the bid, but only if the unsigned bid is accompanied by other material indicating the bidder's intent to be bound.
2. A mistake in a bid discovered after bid opening but prior to award may be withdrawn if the mistake is attributable to an obvious error which shall affect price, quantity, quality, delivery, or contractual conditions, provided:
  - a. The bidder requests withdrawal by submitting proof of evidentiary value which demonstrates that a mistake was made; and
  - b. The Contracting Officer prepares a written approval or denial in response to this request. (Auth: 3-122-31 HAR).

D. After Award.

A mistake in a bid discovered after award is not permissible except when the Manager makes a written determination that it would be unreasonable not to allow the mistake to be remedied. (Auth: 103D-302, HRS, 3-122-31, HAR)

## **2.21 DISCUSSIONS WITH OFFERORS-REQUEST FOR PROPOSALS**

- A. The Department may hold discussions with priority listed offerors in order to promote understanding of the Department's requirements and priority-listed offeror's proposals; and
- B. To facilitate arriving at a contract that will provide the best value to the Department, taking into consideration the evaluation factors set forth in the request for proposals.
- C. Proposals may be accepted on evaluation without discussion.
- D. Any substantial oral clarification of a proposal shall be reduced to writing by the priority-listed offeror;
- E. If during discussions there is a need for any substantial clarification or change in the request for proposals, the request for proposals shall be amended by an addendum to incorporate the clarification or change
- F. Addenda to the request for proposals shall be distributed only to priority-listed offerors.
  - 1. The priority-listed offerors shall be permitted to submit new proposals or to amend those submitted;
  - 2. If in the opinion of the procurement officer or the evaluation committee, a contemplated amendment will significantly change the nature of the procurement, the request for proposals shall be canceled and a new request for proposals issued.

## SECTION 3 - AWARD AND EXECUTION OF CONTRACT

### 3.1 AWARD OF CONTRACT

No contract shall be awarded to any person suspended under, and as provided in, the provisions of Chapters 104 and 444, HRS, as amended and any federal law if federal funds are used in the contract, or to any firm in which such suspended person as an interest.

A. **Bids.**

Award of contract, if made, shall be made to the lowest responsive, responsible bidder, whose bid meets the requirements and criteria set forth in the invitation for bids. (Auth: 3-122-33, HAR)

B. **Proposals.**

Award of contract, if made, shall be made to the responsible offeror whose proposal is determined in writing to provide the best value to the Department taking into consideration price and the evaluation criteria in the request for proposals. (Auth: 3-122-57, HAR)

### 3.2 CANCELLATION OF SOLICITATION OR AWARD

The Contracting Officer reserves the right to reject any and all offers and to waive any defect as, in his or her judgment may be in the best interest of the Department.

The Manager reserves the right to cancel the award of a contract at any time before a contract is executed by the Department and the contractor.

### 3.3 FUNDS, AVAILABILITY OF

A. **Department of Water Funds.**

No contract award shall be binding or of any force and effect without an endorsement by the Waterworks Controller certifying that there is an appropriation sufficient to cover the amount of the contract; provided that if the contract is a multi-term contract, the Waterworks Controller shall only be required to certify that there is an appropriation or balance of an appropriation sufficient to cover the amount required to be paid under the contract during the fiscal year or remaining portion of the fiscal year of each term of the multi-year contract.

This section shall not apply to any contract under which the total amount to be paid to the contractor cannot be accurately estimated at the time the contract is to be awarded. (Auth.: 103D-309 HRS).

B. **State and/or Federal Funds.**

A contract which is supplemented by state and/or federal funds, Section 3.3(A) above shall be applicable only to that portion of the contract price as is payable out of Board funds. As to the portion of the contract price as is expressed in the contract to be payable out of federal funds, the contract shall be construed to be an agreement to pay the portion to the contractor, only out of state and/or federal funds to be received from the state and/or federal government when the state and/or federal

funds are so received by the Board and shall not be construed as a general agreement by the Department to pay said portion out of any funds other than those which are received from the estate and/or federal government. This subsection shall be liberally construed so as not to hinder or impede the County in contracting for any project involving financial aid from the federal government. (3-122-109, HAR)

**C. Contracts Utilizing One-Hundred Percent (100%) Federal Funds.**

A contract which is funded one-hundred percent (100%) by federal funds shall be construed as an agreement to pay the contract price only out of federal funds to be received by the Department from the federal government when the federal funds are so received by the Department and shall not be construed as a general agreement to pay such amount at all events out of any funds other than those which are received from the federal government. (HRS 103D-309(b))

### **3.4 ENTERING INTO CONTRACT**

Upon award of the contract to an offeror, such offeror shall enter into the contract by signing the contract and by furnishing bonds for faithful performance and payment as prescribed in the invitation for bid or proposal, copies of certificates of insurance and endorsements demonstrating compliance with the insurance policies required to be procured by the contractor and subcontractor and tax clearances prescribed in subsection 3.5 within fifteen (15) calendar days after the date the contract has been mailed to the contractor or within such further time as the Manager may allow after the offeror has received the contract for execution.

If the offeror to whom the contract is awarded fails or neglects to enter into the contract and furnish bonds, as prescribed in subsection 3.6, and the copies of certificates of insurance as required by contract, the bid security which accompanied the offer pursuant to subsection 2.9 shall be forfeited or in the case where such bid security was in the form of a surety bond, the proceeds representing the bid security shall be collected under the surety bond and the amount so forfeited or collected shall be paid to the Department. Upon such failure or neglect, the Contracting Officer may award the contract to the next lowest responsible bidder or the next responsible proposer whose proposal is determined to provide the best value to the Department, or publish another call for bids or proposals as, in his or her judgment, may be in the best interests of the Department.

### **3.5 RESPONSIBILITY OF OFFERORS AND TAX CLEARANCE**

Upon award of the contract, HRS 103D-310 specifies that all Offerors shall comply with all laws governing entities doing business in the State, including, but not limited to HRS Chapters 237, 383, 386, 392, and 393.

In addition, pursuant to HRS 103D-328 and HRS 103-53, no contract shall be binding or effective until the purchasing agency confirms tax clearance from the director of taxation and the Internal Revenue Service. The Offeror shall provide updated tax clearances as required by the Director of Finance to comply with HRS Section 103-53, as amended.

The offeror, as proof of compliance with the requirements of section 103D-310(c), HRS, upon award of a contract shall submit, with the contract signed by the offeror, to the



Department verification using Hawai'i Compliance Express for the following requirements:

- A. A tax clearance from the director of taxation and the Internal Revenue Service, current within six (6) months of issuance date, to the effect that all tax returns due have been filed, and all taxes, interest, penalties levied or accrued under the provisions of Title 14 that are administered by the Department of Taxation and under the Internal Revenue Code against the contractor have been paid; and
- B. A certificate of compliance for chapters 383 (Hawai'i Employment Security Law), 386 (Worker's Compensation Law), 392 (Temporary Disability Insurance Law), and 393 (Prepaid Healthcare Act), HRS from the department of labor and industrial relations, current within six months of issuance date; and
- C. A certificate of good standing from the business registration division of the department of commerce and consumer affairs, current within six months of issuance date.

The offeror shall provide updated tax clearances as required by the Contracting Officer to comply with Section 103-53, HRS, as amended.

### **3.6 PERFORMANCE AND PAYMENT BONDS**

- A. Performance and payment bonds shall be required for construction contracts procured through the IFB or RFP process:
  - 1. When the contract price is \$25,000 or more (Act 173, SLH 2012); and
  - 2. When the contract price is less than \$25,000 and is required by the Manager.
  - 3. Federally funded contracts wherein the conditions of the funding requires a performance or payment bond or both.
- B. Performance and payment bonds shall be required for construction contracts procured through the Small Purchase Method (HRS 103D-305):
  - 1. When the contract price is \$50,000.00 or over.
- C. The amount of the performance and payment bonds, when required, shall be in an amount equal to one-hundred percent (100%) of the contract price.
- D. Performance and payment bonds, shall be delivered by the contractor to the Department when the contract is executed. If the contractor fails to deliver the required performance and payment bonds, the contractor's award shall be canceled, the contractor shall be subject to a claim by the Board for all resulting damages its bid security enforced, and award of the contract shall be made to the next lowest offeror pursuant to Subchapter 11, HAR. (Auth: 3-122-224, HAR)

Acceptable forms of performance and payment bonds. Acceptable performance and payment bonds shall be limited to:

1. Surety bond underwritten by a company licensed to issue bonds in the State of Hawai‘i;
  2. Legal tender of the United States of America; or
  3. A certificate of deposit; share certificate; or cashier’s, treasurer’s, teller’s, or official check drawn by, or a certified check accepted by a bank, savings institution, or credit union insured by the United States Federal Deposit Insurance Corporation or the National Credit Union Administration and payable at sight or unconditionally assigned to the Department.
    - a. These instruments may be utilized only to a maximum of \$100,000.
    - b. If the required security or bond amount totals over \$100,000, more than one instrument not exceeding \$100,000 each and issued by different financial institutions which meet the requirements of this subsection shall be accepted. (Auth: 3-122-222, HAR)
- E. The Department shall not pay interest on any security provided.
- F. All alterations, extensions of time, extra and additional work and other changes authorized in the specifications or in any part of the contract may be made without securing the consent of the surety or sureties on the performance and payment bonds.
- G. Surety shall be subject to the approval of the Contracting Officer and shall be required to justify, as prescribed by law, provided that the Contracting Officer in his or her discretion may require each surety to justify in the prescribed amount at any time. If the surety is found to be insufficient, the contractor shall furnish a new bond with sufficient surety within ten (10) calendar days after the day it is notified of the insufficiency or within such further time as the Manager may allow in writing.
- H. Performance and payment bond forms are attached hereto as Exhibits.
- I. Every person who has furnished labor or material to the Contractor for the work provided in the contract for which a payment bond or a performance and payment bond is furnished under this section, and who has not been paid amounts due before the expiration of a period of ninety days after the day on which the last of the labor was performed or material was furnished or supplied, for which a claim is made, may institute an action for the amount, or balance thereof, unpaid at the time of the institution of the action against the Contractor or Contractor and its sureties, on the payment bond and have their rights and claims adjudicated in the action, and judgment rendered thereon; subject to the City's priority on the bond. As a condition precedent to any such suit, written notice shall be given by registered or certified mail to Contractor and surety, within ninety days from the date on which the person did or performed the last labor or furnished or supplied the last of the material for which claim is made, stating with substantial accuracy the amount claimed and the name of the party to whom the material was furnished or supplied or for whom the

labor was done or performed.

- J. Every suit instituted upon a payment bond shall be brought in the circuit court of the circuit in which the project is located, but no suit shall be commenced after the expiration of one year after the day on which the last of the labor was performed or material was supplied for the work provided in the contract. The obligee named in the bond need not be joined as a party in any suit.
- K. If the full amount of the liability of the Contractor or the Contractor and its sureties on the security is insufficient to pay the full amount of the claims, then, after paying the full amount due the City, the remainder shall be distributed pro rata among the claimants. [HAR 3-122-227]
- L. Certified copies of bonds may be requested and obtained by any person upon payment of the costs of reproduction and certification of the bonds, and postage. A certified copy of a bond shall be prima facie evidence of the contents, execution, and delivery of the original. [HAR 3-122-228]
- M. Contracts with Federal funds. In addition to the requirements of this section, whenever a contract is partially or fully funded with Federal funds, the surety companies shall be those listed in the latest issue of the U. S. Treasury Circular 570.

### **3.7 CAMPAIGN CONTRIBUTIONS BY STATE AND COUNTY CONTRACTORS**

If awarded a contract in response to this solicitation, offeror agrees to comply with HRS §11-355, which states that campaign contributions are prohibited from a State and county government contractor during the term of the contract if the contractor is paid with funds appropriated by the legislative body between the execution of the contract through the completion of the contract. Questions regarding this statute should be directed to State of Hawai‘i Campaign Spending Commission.

### **3.8 EMPLOYMENT OF STATE RESIDENTS ON CONSTRUCTION PROCUREMENT CONTRACTS**

Bidders are advised of the applicability of Act 68, SB 2840, HRS Section 103B, Employment of State Residents on Construction Procurement Contracts, (2010) (“Act 68”). Act 68 requires the awarded contractor to ensure that Hawai‘i Residents (as defined in the Act) compose not less than eighty percent of the workforce employed to perform the contract. This requirement shall also apply to subcontracts of \$50,000 or more in connection with any construction contract procured under HRS Chapter 103D, HRS § 103D-305 (small purchases), or if there is a conflict with any federal law as further detailed herein under “Conflict with Federal Law.” See Exhibit O.

### **3.9 HAWAII PROCUREMENT LAW**

If any provision in this General Provisions is in conflict with any provision in the Hawai‘i Administrative Rules, Chapter 103D and 103, HRS, the provisions of the Hawai‘i Administrative Rules, Chapter 103D and 103, HRS shall control and supersede the provisions in this General Provisions.

## **SECTION 4 - LEGAL RELATIONS AND RESPONSIBILITY**

### **4.1 AUTHORITY OF THE CONTRACTING OFFICER**

The Contracting Officer shall decide all questions which may arise relating to the quality and acceptability of the materials furnished and work performed, the manner of performance and rate of progress of the work, the interpretation of the plans and specifications, the acceptable fulfillment of the contract on the part of the Contractor, the compensation under the contract and the mutual rights of the parties to the contract.

The Contracting Officer shall have the authority to enforce and make effective such decisions and orders which the Contractor fails to carry out promptly and diligently.

The Contracting Officer shall have the authority to suspend the work wholly or in part due to the failure of the Contractor to correct conditions unsafe for the workers or the general public; for failure to carry out provisions of the contract; for failure to carry out orders; for such periods as he may deem necessary due to unsuitable weather; for conditions considered unsuitable for the prosecution of the work or for any other condition or reason deemed to be in the public interest.

### **4.2 INDEPENDENT CONTRACTOR**

- A. The contractor shall perform the contract as an independent contractor and shall defend, indemnify and hold harmless the Department, Board, its officer, agents, and employees from and against all claims, damages, losses, liability, and expenses, including but not limited to attorney's fees, court costs, or other alternative dispute resolution costs arising out of, resulting from, or otherwise but for the performance or furnishing of work or services under the contract for any injury, death or damages to persons or property arising out of the performance of the contract; but only to the extent caused in whole or in part by the actual or alleged acts, errors, or omissions of the Contractor, Contractor's subcontractor(s), or anyone directly or indirectly employed or hired by the Contractor or anyone for whose acts Contractor may be liable.
- B. The obligations of the contractor under Subparagraph A above shall not extend to the liability of the Department, Board, and its officers and employees because of negligence in (1) the preparation of maps, plans, drawings, land surveys, designs or specifications, or (2) the giving of directions or instructions with respect to the requirements of the contract by written order; provided that such giving of directions or instructions is the primary cause of the injury or damage.
- C. The contractor shall defend, indemnify and save the Department, Board, its officers, agents, and employees harmless from any and all claims for infringement by reason of the use of any patented design, device, process or material, in connection with work to be performed under the contract.

All royalties due or becoming due for the use of any patented design, devices, process or material used in connection with the work performed under the contract shall be paid by the contractor, and shall be held to be included in the contract price.

- D. The contractor shall agree to defend, indemnify and save harmless the Department against any and all deaths, injuries, losses and damages to persons or property, and any and all claims, demands, costs, liabilities, suits, judgments, actions or proceedings of every name, character and description which may be suffered or incurred by or brought against the Department to the extent arising from contractor's negligent performance of his or her duties and responsibilities pursuant to this contract except where said liability, loss or damage results solely from the negligence or misconduct of Department, Board, its employees or representatives.

### **4.3 LAWS, REGULATIONS**

The contractor shall at all times keep himself fully informed, of all future and present Federal, State, County, and Department laws, ordinances, policies, rules and regulations which affect the contract and the performance thereof, including but not limited to:

- A. Chapter 103, HRS, relating to expenditure of Public Money and Public Contracts.
- B. Chapter 103D, HRS, relating to the Hawai'i Public Procurement Code.
- C. Chapter 104, HRS, relating to Wages and Hours of Employees on Public Works.
- D. Chapter 321, HRS, relating to Health Department.
- E. Chapter 377, HRS, relating to Hawai'i Employment Relations Act.
- F. Chapter 378, HRS, relating to Employment Practices.
- G. Chapter 383, HRS, relating to Hawai'i Employment Security Law.
- H. Chapter 386, HRS, relating to Worker's Compensation Law.
- I. Chapter 387, HRS, relating to Wage and Hour Law.
- J. Chapter 388, HRS, relating to Payment of Wages and Other Compensation.
- K. Chapter 390, HRS, relating to Child Labor Law.
- L. Chapter 396, HRS, relating to Occupational Safety and Health.
- M. Chapter 444, HRS, as amended, relating to licensing of contractors.

The contractor shall comply with all such present and future laws, regulations, and ordinances, including the giving of all notices necessary and incident to the performance of the contract. If any discrepancy or inconsistency is discovered between the contract and any such law, regulation or ordinance, the contractor shall forthwith report the same in writing to the Contracting Officer.

#### **4.4 PERMITS, LICENSES**

The contractor shall obtain all permits, licenses and approvals required by the Department, County, State, or Federal Government, for the execution of the contract, and pay all charges and fees therefore including, but not limited to overtime inspection, cost of preparation of documents, and any and all other costs associated with attaining required permit approvals.

#### **4.5 NO PERSONAL LIABILITY**

Neither the Contracting Officer nor the Board nor any other officer or employee of the Department, in the performance of their duties, shall incur personal liability to the contractor for any action taken in good faith.

#### **4.6 COORDINATION OF SPECIAL PROVISIONS, PLANS, SPECIFICATIONS, GENERAL PROVISIONS, WATER STANDARDS, AND OTHER PARTS OF THE CONTRACT DOCUMENTS**

The special provisions, plans, specifications, general provisions, Water Standards, contract documents and all supplemental documents are essential parts of the contract, and a requirement occurring in one is as binding as though occurring in all. They are intended to be complementary and to describe and provide for the complete work. In case of conflict or discrepancy within any part of the contract, the stricter requirements, including Hawai'i State Statutory requirements, shall govern. Unless it is apparent that a different order of precedence is intended, the following is the precedence list with 1 taking precedence over two, two taking precedence over three, etc.:

1. Special Provisions
2. Plans
3. Specifications/Request for Proposals
4. Agreement Documents
5. General Provisions
6. Water Standards
7. Other Agency Standards

Instructions to offerors, addendas and the pre-bid or pre-proposal meeting minutes are hereby incorporated by reference and made a part of the Special Provisions.

#### **Hawaii Standard Specifications for Road, Bridge and Public Works Construction, 2005.**

Unless otherwise specified, the means and methods of Hawai'i Standard Specifications for Road, Bridge and Public Works Construction, 2005, as amended, shall govern the requirements for construction within all State and County roadway rights-of-way.

## SECTION 5 - SCOPE OF CONTRACT

### 5.1 SCOPE OF CONTRACT

The scope of the contract encompasses the contractor's furnishing of, and payment for, all labor, supervision, skills, materials, tools, transportation, equipment and apparatus, and all incidentals necessary to perform all the work and do all the things necessary in accordance with the provisions of the contract documents by the contractor. See Sample Contract attached hereto as Exhibit J.

### 5.2 REQUESTS FOR INFORMATION

A. **Request for Information (RFI)** - An RFI is a written request, using attached Form Exhibit P from the contractor to the Contracting Officer, seeking an interpretation or a clarification of some requirement of the contract documents. The contractor shall clearly and concisely set forth the issue for which they seek clarification or interpretation and why a response is needed from the Department. The Contractor shall, in the RFI, set forth their interpretation or understanding of the requirement including reasons why they have reached such an understanding. Responses from the Department will not change any requirement of the contract documents unless so noted in the RFI Response by the Department.

1. The following is a non-exhaustive list of what shall NOT be accepted as an RFI:
  - a. Submittals for clearly identifiable items that should have been addressed pre-bid.
  - b. Numerous and excessive RFIs that are meant to overwhelm the Department.
  - c. Proposal for alternative construction methods or substitute items.
  - d. RFIs that are meant to address construction means and methods or site safety.
2. RFIs can only be submitted by the Contractor. Submittals by subcontractors shall be rejected outright.
3. Each RFI shall be limited to a single subject of inquiry.
4. All RFIs shall be accompanied by a lowest-cost suggested solution from the Contractor.
5. All RFIs shall include the necessary attachments and exact references. When applicable, references to design drawing numbers and specification sections and a graphic depiction of the resolution shall accompany the RFI.

6. RFIs that fail to conform to these requirements will be rejected at no fault to the Department.

B. **Response to RFI**

Response to an RFI shall be issued within ten (10) working days of receipt of the request from the contractor unless the Contracting Officer determines that a longer period of time is necessary to provide an adequate response. If a longer period of time is determined necessary by the Contracting Officer, the Contracting Officer will, within ten (10) working days of receipt of the RFI, notify the contractor of the anticipated response time.

1. The ten (10) working days referred to herein will start on the date stamped “Received” by the Department and ends on the date stamped “Sent” by the Department.
2. If the contractor submits a RFI on a schedule activity within ten (10) working days or less of float on a current project schedule, the contractor shall not be entitled to any time extension due to the time it takes the Department to respond to the request provided that the owner responds within ten (10) working days set forth above.
3. Responses to RFIs that require revisions to drawings and specifications should be incorporated into the design drawings concurrent with the processing of the RFI.

- C. Responses from the Department will not change any requirement of the contract documents unless so noted by the Department in the response to the RFI. In the event the Contractor believes that a response to a RFI will cause a change to the requirements of the contract document, the contractor shall provide written notice to the owner in accordance with the requirements of Section 5.3 of this Document. Failure to provide such written notice shall waive the contractor’s right to seek additional time or cost as laid out in Section 5.3 of this Document.

### **5.3 MODIFICATIONS TO THE WORK**

A. **Oral Directive.**

Any directive, direction, instruction, interpretation or determination through oral order, or email (“oral directive”) from the Contracting Officer, which, in the opinion of the contractor, causes any change, can be considered as a change only if the contractor gives the Contracting Officer written notice of its intent to treat the oral directive as a change directive. The written notice must be delivered to the Contracting Officer before the contractor acts in conformity with the oral order, direction, instruction, interpretation or determination, but not more than five days after delivery of the oral order to the contractor. The written notice shall state the date, circumstances, whether a time extension will be requested, and source of the order that the contractor regards as a change. The written notice may not be waived and shall be a condition precedent to the filing of a claim by the contractor. Unless the contractor acts in accordance with this procedure, any oral directive shall not be treated as a change and the contractor waives any claim for an increase in the



contract time or contract price related to the work.

B. **Change Order.**

The Contracting Officer, at any time, and without notice to any surety, in a signed writing designated or indicated to be a change order, may unilaterally make changes in the work within the scope of the contract as may be found to be necessary or desirable and may unilaterally make changes in the time of performance of the contract that does not alter the scope of the contract work. Such changes shall not invalidate the contract or release the sureties, and the contractor will perform the work as changed, as though it had been part of the original contract. Minor changes in the work may be directed by the Contracting Officer at no change in contract price or time. Change Order form is attached hereto as Exhibit K.

1. Adjustment of price or time for performance. If any change order increases or decreases the contractor's cost of, or the time required for, performance of any part of the work under this contract, whether or not changed by the order, an adjustment shall be made and the contract modified in writing accordingly. Any adjustment in contract price made pursuant to this clause shall be determined in accordance with the price adjustment clause of this contract or as negotiated.
2. Failure of the parties to agree to an adjustment shall not excuse a contractor from proceeding with the contract as changed, provided that the Contracting Officer, within fourteen (14) calendar days after the changed work commences, makes such provisional adjustments in time for the direct costs of the work as the Contracting Officer deems reasonable.
3. Quotations for modification of work shall be submitted expeditiously and in any case no later than ten (10) working days after receipt of the Department of Water's request. All quotations shall be accompanied by a detailed written statement setting forth all charges the Contractor proposes for the change, properly itemized, and supported by sufficient substantiating data to permit evaluation of charges. All quotations shall be accompanied by a statement as to the proposed change's effect on the project's completion date. If no condition is stipulated, the Department of Water will assume that the acceptance of the quotation will have no adverse effect on the project's completion date.
4. The Contracting Officer has up to twenty (20) days to make a final decision as to whether to accept the entire cost proposal or any discrete cost item contained within the cost proposal or the proposed adjustment to contract time by a contract change order.
5. The right of the contractor to dispute the contract price or time or both shall not be waived by the contractor performing the work, provided however, that the contractor follows the notice requirements for disputes and claims established by the contract or these provisions. Contract Modification Form is attached hereto as Exhibit L.

6. Time period for claim. Within thirty (30) calendar days after receipt of a written change order under subsection, unless such period is extended by the Contracting Officer in writing, the contractor shall file notice of intent to assert a claim for an adjustment. The requirement for timely written notice cannot be waived and shall be a condition precedent to the assertion of a claim.
7. Claim barred after final payment. No claim by the contractor for an adjustment hereunder shall be allowed if notice is not given prior to final payment under this contract.
8. No payment shall be allowed to the Contractor for pricing or negotiating proposed or actual changes. No time extension will be granted for delay caused by late Contractor pricing of changes or proposed changes.
9. Additional performance bond or payment bond may be required by the procurement officer for a contract change order or modification where the contract amount increases. (HAR 3-122-225)
10. Other Claims Not Barred. In the absence of such a change order, nothing in this clause shall restrict the contractor's right to pursue a claim arising under the contract or for breach of contract. (HAR 3-125-4)

#### **5.4 PRICE ADJUSTMENT**

- A. Any adjustment in contract price shall be made in one or more of the following ways:
  1. By agreement on a fixed price adjustment before commencement of the pertinent performance or as soon thereafter as reasonably practicable;
  2. By unit prices specified in the contract or subsequently agreed upon;
  3. By the costs attributable to the events or situations under such clauses with adjustment of profit or fee, all as specified in the contract or subsequently agreed upon before commencement of the pertinent performance;
  4. In such other manner as the parties may mutually agree; or
  5. In the absence of agreement between the parties, the provisions of HRS 103D-501(b)(5) shall apply.
- B. Submission of cost or pricing data. The contractor shall be required to submit cost or pricing data if any adjustment in contract price is subject to the provisions of section 103D-312, HRS. The submission of any cost or pricing data shall be made subject to the provisions of subchapter 15, chapter 3-122, HAR. A fully executed change order or other document permitting billing for the adjustment in price under any method listed shall be issued within ten (10) days after agreement on the method

of adjustment.

- C. Determining Adjustments in Price. In determining the adjustment in price to the Department resulting from a change, the allowances for all overhead and extended overhead resulting from adjustments to contract and profit combined, shall not exceed the percentages set forth below per Chapter 3-125, HAR:
1. For the contractor, for any work performed by its own labor forces, twenty percent (20%) of the cost;
  2. For each subcontractor involved, for any work performed by its own forces, twenty percent (20%) of the cost;
  3. For the contractor or any subcontractor, for work performed by their subcontractors, ten percent (10%) of the amount due the performing subcontractor.

Not more than three (3) line item percentages for fee and overhead, not to exceed the maximum percentages shown above, will be allowed regardless of the number of tier subcontractors.

- D. The Department, in determining an adjustment in price using any of the methods listed in 5.4 A (1-4) above may not mandate that the contractor submit its proposal for a price adjustment at a specified percentage that it unilaterally considers to be acceptable.
- E. Paragraphs C. and D., herein, shall not be construed to impair the right of the Contractor and the Department from mutually agreeing to a price adjustment under any method listed in 5.4 A (1-4).

## 5.5 DIFFERING SITE CONDITIONS

**Differing Site Conditions - Contractor's Responsibility.** Unless otherwise noted, the contractor accepts the conditions at the construction site as they eventually may be found to exist and warrants and represents that the contract can and will be performed under such conditions, and that all materials, equipment, labor, and other facilities required because of any unforeseen conditions (physical or otherwise) shall be wholly at the contractor's own cost and expense, anything in this contract to the contrary notwithstanding. (H.A.R. 3-125-11)

## 5.6 ASSIGNMENT, CHANGE OF NAME, NOVATION

- A. **No Assignment.**  
No Department contract is transferable, or otherwise assignable, without the written consent of the Manager; provided that a contractor may assign moneys receivable under a contract after due notice to the Department.
- B. **Recognition of a successor in interest; assignment.**  
When in the best interest of the Department, a successor in interest may be recognized in an assignment agreement in which the transferor and the transferee

and the Department shall agree that:

1. The transferee assumes all of the transferor's obligations;
2. The transferor remains liable for all obligations under the contract but waives all rights under the contract as against the Department; and
3. The transferor shall continue to furnish, and the transferee, shall also furnish all required bonds.

C. **Change of Name.**

When a contractor requests to change the name in which he or she holds a contract with the Department, the Manager shall, upon receipt of a document indicating such change of name (for example, an amendment to the articles of incorporation of the corporation), enter into an agreement with the requesting contractor to effect such a change of name. The agreement changing the name shall specifically indicate that no other terms and conditions of the contract are thereby changed. (Auth: 3-125-14, HAR)

## 5.7 VALUE ENGINEERING INCENTIVE

A. **Definitions** as used in this section:

"Net savings" means those savings in project costs realized by the Department as the result of a value engineering change proposal after deducting the contractor's share of the cost savings.

"Single contract" means the single construction for which the cost savings is proposed.

"Value engineering" means an analysis of the requirements for the systems, equipment, and supplies of the single contract for the purpose of achieving a net savings by providing less costly items than those specified without impairing any essential functions and characteristics as service life, reliability, substitutability, economy of operations, ease of maintenance, and necessary standing functions.

"Value engineering change proposal" means a cost reduction proposal based on value engineering submitted by the contractor pursuant to this chapter and particularly identified as such. (HAR §3-132-1)

B. **Applicability.**

1. The provisions of this chapter shall apply to all construction contracts in excess of \$100,000. The application of value engineering incentives to contracts shall not be construed to have an effect on the solicitation or the selection of the contractor.
2. The contractor may develop and submit value engineering change proposals for drawings, designs, specifications, or other requirements of the contract. If any proposal is accepted and approved, in whole or in part, by the

procurement officer, the contract shall be modified and shall include an equitable adjustment of the contract price in accordance with this section.

3. This section shall not apply to any cost reduction proposal that is not identified as a value engineering change proposal by the contractor at the time of its submission to the procurement officer. (HAR §3-132-2)

C. **Section provisions.**

1. The processing of a value engineering change proposal shall be similar to that for any proposed contract change order and shall be considered only after the construction contract is awarded.
2. Nothing herein shall be construed to mean that the Department must accept or approve any or all value engineering change proposals submitted in accordance with this section. The OIC's interpretation and findings relative to the impairment of the functions or characteristics of the item or items covered by the value engineering change proposal shall be final.
3. Adjustment in contract prices and allowances for implementation costs shall be in accordance with this section and shall only be considered if and when the value engineering change proposal is approved by the contract officer. The receipt of the value engineering change proposal by the Department or a verbal acceptance of a value engineering change proposal by any employee of the Department shall not obligate the Department to accept the value engineering change proposal.
4. The contract officer may impose, as a condition of acceptance of any value engineering change proposal, a requirement that the contractor warrant the statements, claims, and other information contained in the value engineering change proposal. In addition, the contractor's responsibility under any such warranty shall be in addition to the liability imposed by the "guarantee of work" requirement as included in the contract.
5. The contractor shall be responsible for the new design of the facility or a portion of the facility submitted as a value engineering change proposal, including errors and omissions and, if the value engineering change proposal is for a portion of the facility, for any adverse impacts the new design may have on the unchanged portions of the facility.

D. **Conditions for a value engineering change proposal.**

1. A value engineering change proposal to a contract shall:
  - a. Result in an estimated net savings to the Department in the project cost of at least four thousand dollars (\$4,000.00) by providing less costly items than or using different construction methods from those specified in the contract without impairing any essential functions and characteristics as service life, reliability, substitutability, economy of operation, ease of maintenance, and necessary standardized features of the completed work;

- b. Require, in order to be applied to the contract, a change order to the contract; and
  - c. Not adversely impact on the performance schedule or the contract completion date.
2. As a minimum, the following information shall be submitted by the contractor with each value engineering change proposal:
- a. A description of the difference between the existing contract requirements and the value engineering change proposal and the comparative advantages and disadvantages of each including durability, service life, reliability, substitutability, economy of operation, ease of maintenance, desired appearance, design, safety standards, impacts due to construction, and other essential or desirable functions and characteristics as appropriate;
  - b. An itemization of the requirements of the contract which must be changed if the value engineering change proposal is adopted and are commendation as to how to make each change;
  - c. An itemized estimate of the reduction in performance costs that will result from adoption of the value engineering change proposal or parts thereof taking into account the costs of implementation by the contractor, including any amounts attributable to subcontractors, and the basis for the estimate;
  - d. A prediction of any effects and impacts the value engineering change proposal would have on: other costs to the Department as the costs of Department-furnished property, related items, and maintenance and operation over the anticipated life of the material, equipment, or facilities as appropriate; the construction schedule, sequence and time; and bid item totals used for evaluation and payment purposes;
  - e. A statement of the time by which a change order adopting the value engineering change proposal must be issued so as to obtain the maximum cost reduction during the remainder of the contract, noting any effect on the contract time; and
  - f. If previously submitted, the date(s) of any previous submission(s), the contract number(s) of those contract(s) for which it was submitted and the previous action(s) by the Department, if known;
3. When, in the judgment of the Contracting Officer, a value engineering change proposal alters the design prepared by a registered professional architect or engineer, the contractor shall ensure the changes to be prepared are by or under the supervision of a registered professional architect or engineer, and stamped and so certified.

4. A value engineering change proposal will be processed expeditiously and in the same manner as prescribed for any other proposal which would likewise necessitate issuance of a contract change order. Unless and until a change order applies a value engineering proposal to a contract, the contractor shall remain obligated to perform in accordance with the terms of the contract and the Department shall not be liable for delays incurred by the contractor resulting from the time required for the Department's determination of the acceptability of the value engineering change proposal. The determination of the procurement officer as to the acceptance of any value engineering change proposal under a contract shall be final.
5. The Contracting Officer may accept in whole or in part any value engineering change proposal submitted pursuant to this section by issuing a change order to the contract. Prior to issuance of the change order, the contractor shall submit complete final contract documents similar to those of the original contract showing the accepted changes and the new design and features as well as the following:
  - a. Design calculations;
  - b. The design criteria used; and
  - c. A detailed breakdown of costs and expenses to construct or implement such revisions. The change order will identify the final value engineering change proposal on which it is based.
6. When a value engineering change proposal submitted pursuant to this section is accepted under a contract, an equitable adjustment in the contract price and in any other affected provisions of the contract shall be made in accordance with this section and the "change order" clause of the contract. The equitable adjustment shall first be established by determining the effect on the contractor's cost of implementing the change, including any amount attributable to subcontractors and to the Department's charges to the contractor for architectural, engineering, or other consultant services and the staff time required to examine and review the proposal. The contract price shall then be reduced by fifty per cent (50%) of the net estimated decrease in the cost of performance.
7. The contractor may restrict the Department's right to use the data or information or both on any sheet of a value engineering change proposal or of the supporting data, submitted pursuant to this section, if it is stated on that sheet as follows:

"This data or information or both shall not be disclosed outside the Department, or be duplicated, used, or disclosed, in whole or in part, for any purpose other than to evaluate this value engineering change proposal. This restriction does not limit the Department's right to use this data or information or both if obtained from another source, or is otherwise

available, without limitations. If this proposal is accepted by the Department by issuance of a change order to the contract after the use of this data or information or both in such an evaluation, the Department shall have the right to duplicate, use and disclose any data or information or both pertinent to the proposal as accepted, in any manner and for any purpose whatsoever, and have others so do”.

8. In the event of acceptance of a value engineering proposal, the Department shall have all rights to use, duplicate, or disclose in whole or in part, in any manner and for any purpose whatsoever, and to have or permit others to do so, any data or information or both reasonably necessary to fully utilize such proposal.
9. Notwithstanding the provisions of this section, for any construction contract, the contractor shall not be precluded from making substitution requests in accordance with applicable rules and policies of the Department. The OIC shall be the sole judge of whether a proposal is a value engineering change proposal or a substitution request. (HAR §3-132-4)

E. **Value engineering sharing method.** The method by which the contractor will share a portion of the cost savings from an accepted value engineering change proposal shall be in accordance with section 3-132-4 and the following:

1. The contractor’s share in cost savings shall be for the single contract only, and no consideration shall be made for future acquisition, royalty type payment, or collateral savings.
2. The Department may accept the proposed value engineering change proposal, in whole or in part. The engineer shall issue a contract change order or modify the contract to identify and describe the accepted value engineering change proposal. (HAR §3-132-6)

## 5.8 SUBSTITUTIONS

A. **After Bid Opening.** Substitution of material or equipment may be allowed after the bid opening date only if:

1. The specified or prequalified item is delayed by a lengthy strike in the factory or other unforeseeable contingency beyond the control of the Contractor which would cause an abnormal delay in the project completion; or
2. All specified or prequalified items are found to be unusable or unavailable due to change or other circumstances; or
3. The Contractor is willing to provide a more recently developed or manufactured model of material or equipment of the same name manufacturer which the Contracting Officer determines to be equal or better than the one specified or prequalified.



A substitution request, regardless of reason, shall be fully explained in writing, by the Contractor including his justification for said request, quantities and unit prices involved, quotations and such other documents as are deemed necessary to support the request.

Any savings in cost will be rebated to the Department and any additional cost for the substituted items will be paid for by the Contractor.

The above shall not be construed to mean that substitutions for brand name specified materials and equipment will be allowed; the Contracting Officer reserves the right to reject and deny any request deemed irregular or not in the best interest of the Department and a request for substitution shall not in any way constitute a justification for an extension of contract time.

## **5.9 EXTRA WORK**

No work of any kind in connection with the work covered by the specifications and plans shall be considered as entitling the Contractor to extra compensation except when the work is ordered in writing, as a change order, by the Contracting Officer.

## **5.10 PAYMENT FOR DELETED MATERIALS**

- A. Canceled Orders – If acceptable material was ordered by the Contractor for any item deleted by an ordered change in the work prior to the date of notification of such deletion by the Contracting Officer, the Contractor shall use every reasonable effort to cancel the order. The Department shall pay reasonable cancellation charges required by the supplier excluding any markup for overhead and profit to the Contractor.
- B. Returned Materials – If acceptable deleted material is in the possession of the Contractor or is ultimately received by the Contractor, if such material is returnable to the supplier and the Contracting Officer so directs, the material shall be returned and the Contractor will be paid for the reasonable charges made by the supplier for the return of the material, excluded any markup for overhead and profit to the Contractor. The cost to the Contractor for handling the returned material will be paid for as provided in Subsection 5.4 “Price Adjustment.”
- C. Uncanceled Materials – If orders for acceptable deleted material cannot be canceled at a reasonable cost, it will be paid for at the actual cost to the Contractor including an appropriate markup for overhead and profit as set forth in Subsection 5.4 “Price Adjustment” In such case, the material paid for shall become the property of the Department of Water and the contractor shall deliver to the Department of Water Baseyard.

## **SECTION 6 - PERFORMANCE OF CONTRACT**

### **6.1 TIME**

Time is of the essence of the contract. Performance of the contract shall be commenced on the commencement date designated in the notice to proceed and shall be completed within the contract time specified in the contract or as computed or extended in accordance with the provisions of subsection 8.3.

- A. After the contract is completely executed, the Contracting Officer will issue the contractor a written "Notice to Proceed" designating the official date for the commencement of the work. The contractor shall submit all materials for approval. Once all materials for use on the project have been approved, the contractor shall arrange a preconstruction conference with the Contracting Officer, along with other affected agencies, firms and individuals at least ten (10) calendar days prior to the starting date for construction.

At the preconstruction conference, the contractor shall submit to the Department, the name, local address and telephone number(s) of his or her authorized superintendent of the job.

No construction work shall commence until the contractor has notified the Contracting Officer, in writing, at least one (1) week in advance of the actual date he or she will start the work to be done under the contract after the notice to proceed, and shall diligently prosecute the same to completion within the time limit provided in the contract. The contractor shall be entirely responsible for any delay in the work caused by his or her failure to give such notice to the Contracting Officer.

- B. When the contract time is on a working day basis, the Contracting Officer will furnish the contractor a weekly statement showing the number of days charged to the contract for the preceding week and the number of days specified for completion of the contract. The contractor will be allowed seven (7) days in which to file a written protest setting forth in what respect said weekly statement is incorrect; otherwise the statement shall be deemed to have been accepted by the contractor as correct.
- C. When the contract time is on a calendar-day basis, it shall consist of the number of calendar days stated in the contract beginning with the effective date of the NOTICE TO PROCEED, including all Sundays, holidays and non-working days. All calendar days elapsing between the effective dates of any orders of the Contracting Officer to suspend work and to resume work for suspensions not the fault of the contractor shall be excluded.

### **6.2 PERFORMANCE SCHEDULE**

Within seven (7) calendar days after the commencement of the contract, or such further time as may be allowed by the Contracting Officer, the contractor shall submit for the approval of

the Contracting Officer, a practicable schedule utilizing the critical path method (CPM) for the performance of the contract. The date on which parts of the project, including the procurement of materials, plant and equipment, have been or will be started, and the contemplated dates for completion of parts of the project. If the schedule is not approved, it shall be revised as directed by the Contracting Officer. After approval, no changes in the schedule shall be made without the approval of the Contracting Officer. The approved schedule shall be updated with a three-week (3-week) schedule breakdown and two (2) copies submitted to the Department weekly, and a full schedule breakdown submitted to the Department monthly with payment request for approval. The updated schedule shall show the actual progress of work compared to the approved schedule or the latest amended schedule. The updated schedule shall be used as a basis for establishing major construction and as a check on the progress of the work performed under the contract. All schedules shall be provided via hard copy and as a Microsoft Project file/PDF file.

- \* The full schedule shall include a written narrative explaining CPM network.
- \* The full schedule shall account for dealing with predictable “planned (normal) adverse weather based on historical averages and be reflected appropriately.
- \* The Contracting Officer does not dictate means, methods, or schedule as that is the contractors responsibility and discretion.
- \* The Contracting Officer will review the CPM network for reasonableness and conformance with the plans, specifications and contract time at the baseline review and with each update.
- \* Any acceleration to schedule pursuant to a directive by the owner shall be in writing.
- \* Project float is a shared resource for use by contractor and owner in good faith.

### **6.3 OWNER-CONTRACTOR MEETING, FIELD OFFICE AND FIELD TELEPHONE**

#### **A. Owner-Contractor Meeting.**

A weekly meeting is required at the jobsite field office. The meeting attendees at minimum shall be the contractor project manager and foreman, DOW project manager and inspector, and other construction related staff. The contractor shall prepare the meeting minutes and provide to the DOW construction team one day prior to next weekly meeting.

#### **B. Field Office.**

The contractor shall provide a field office for the Manager at a location designated by the Manager within the project site. It shall be available within seven (7) calendar days after issuance of Notice to Proceed for the work under the contract. The field office shall be weather-proof and not less than 120 square feet in gross floor area. The aggregate window areas of the office shall not be less than 10 percent (10%) of the floor area, and one (1) exterior door shall be provided with a keyed cylinder-type lock. The office shall be furnished with one (1) drafting-type table having a dimension of not less than 3' x 6' and a stool, adequate plan racks and hangers, one (1) desk, two (2) chairs, shelves, a broom, telephone service, air conditioning, electric lighting, paper towels, paper cups, soap, toilet paper and potable water, and shall be maintained in good repair and in a clean and sanitary condition by the contractor. If the office is not equipped with a water closet and lavatory, the contractor shall make other arrangements to provide such facilities for the Manager.

C. **Field Telephone.**

If required in the special provisions, the contractor shall provide a field telephone for the Manager. Such field telephone shall be placed at a convenient and accessible location.

**6.4 DOCUMENTS TO BE KEPT ON SITE**

The contractor shall keep a copy of the request for proposals, special provisions, current water system standards current standard specifications for Road and Bridge construction, approved construction drawings, approved submittals, RFI responses, approved permits, and specifications of the contract on the site of the project readily accessible for reference.

**6.5 ADDITIONAL PLANS AND SPECIFICATIONS TO BE FURNISHED BY THE CONTRACTING OFFICER**

If deemed necessary by the Contracting Officer, the Contracting Officer may furnish, by written order, such additional plans and specifications, during the performance of the contract as may be necessary to clarify the contract or define it in greater detail, and the contractor shall comply with such additional plans and specifications. Such additional plans and specifications shall become a part of the contract.

**6.6 DRAWINGS TO BE FURNISHED BY CONTRACTOR**

Shop drawings means drawings, submitted to the Department by the Contractor which shows in detail 1) the proposed fabrication and assembly of structural elements, and 2) the installation (i.e., form, fit, and attachment details) of materials or equipment. It includes drawings, diagrams, layouts, schematics, descriptive literature, illustrations, schedules, performance and test data and similar materials furnished by the Contractor to explain in detail specific portions of the work required by the contract.

The Contractor shall coordinate all such drawings, and review them for accuracy, completeness, and compliance with approved construction drawings, specifications and other applicable contract requirements and shall indicate its approval thereon as evidence of such coordination and review. The Contractor shall make and supply such working or shop drawings as may be required by the Contracting Officer during the performance of the contract. The drawings shall be finished plans, and shall be neat, legible and drawn to scale. Drawings submitted without evidence of the Contractor's approval may be returned for resubmission.

The contractor shall submit three (3) prints of working or shop drawings to the Contracting Officer for approval prior to the commencement of the work under the contract or the delivery to the project site of any equipment or material covered by the drawings, whichever is later. The Contracting Officer, has twenty (20) days to approve or disapprove and will indicate such approval or disapproval of the shop drawings. If not approved as submitted the Contracting Officer shall indicate the reasons therefor. The Contracting Officer may require the drawings to be resubmitted as often as necessary to render them complete, legible and free of extensive corrections. If a resubmittal is required, the Contracting Officer shall return one (1) print to the contractor who shall make all the corrections or drawings for

approval. Any work done before such approval shall be at the Contractor's risk.

After approval, no working or shop drawings shall be changed without the written approval of the Contracting Officer; and the contractor may proceed with the parts of the project called for in such drawings.

It shall be expressly understood that review and approval of working or shop drawings and other submittals by the Contracting Officer shall not be construed to relieve the contractor of responsibility for any errors and omissions in such drawings, or the accuracy of dimensions and details and duty to perform the contract in accordance with the approved construction drawings, specifications, terms, covenants, conditions, provisions and intent thereof. It is further understood that the review and approval by the Contracting Officer of the Contractor's shop drawings, whether general or detailed, is a general review relating only to their sufficiency and compliance with the intention of the contract. The Contractor shall clearly identify and inform the Contracting Officer in writing on the shop drawing transmittal cover sheet of any deviations from the contract documents at the time of submission and shall obtain the Contracting Officer's written approval to the specified deviation prior to proceeding with any work. The contractor, at his own risk and expense, may elect to proceed with the work affected by the drawings prior to final review.

Catalog cuts or similar reproductions may be substituted for working or shop drawings in the case of assembled electrical, mechanical units and other waterworks materials to be installed, when they show information which the Contracting Officer determines to be sufficient for review and approval. The contractor shall provide all additional information that is requested by the Contracting Officer during the review and approval process.

## **6.7 OMISSION IN CONTRACT**

Unless specified, work which is otherwise incidental to the contract although not specifically referred to in the contract shall be furnished and performed by the contractor. Labor, materials, equipment, overhead, and extended overhead directly or indirectly necessary to complete the construction of the project, whether or not the same may have been expressly provided for in the contract, shall be furnished and performed by the contractor.

## **6.8 CONTRACTOR TO REPORT ERRORS OR DISCREPANCIES**

The contractor shall notify the Contracting Officer in writing immediately upon discovery of any error or omission in the layout given by stakes, points or instructions furnished by the Manager, or any discrepancy within the contract, or any part thereof or between the plans and the conditions of the site.

After such discovery, the contractor shall proceed with the performance of the contract only after receiving written approval from the Contracting Officer.

## **6.9 CONTROL OF THE CONTRACT**

### **A. Workmanship.**

The contract shall be performed in an orderly and workmanlike manner in

accordance with the latest acceptable practice and shall be of the best quality, except as clearly specified otherwise. Whenever there is a doubt as to what is permissible or the contract fails to note the quality of any work, the interpretation which calls for the best quality of work is to be followed.

**B. Access to the Project.**

During the performance of the contract, the contractor shall provide the Department with proper and safe facilities for access to the site of the project and the shops of the contractor and the subcontractor.

Other contractors of the Department shall be permitted access to the site of the project when it is required for performance of their respective contractors.

**C. Inspection.**

The performance of the contract shall be subject to the inspection of the Department, and the contractor shall supply such information and assistance as may be required to make a complete and detailed inspection. The Department may inspect each and every subdivision of the work or any part or parts or process thereof. The Department's staff shall have free access to all parts of the work at all times and shall be given every facility, information, and means of thoroughly inspecting the work done and the materials used or to be used. No work or material which may be defective in construction or quality or deficient in any of the requirements of the plans, specifications, special provisions or other contract documents will be accepted. The Department's presence or inspection on the site will not relieve the contractor of his or her deficiencies.

If the contractor wishes to work at such time of the day which is during the period other than the regular business hours of the Department of Water, County of Kaua'i or on a Saturday, Sunday or legal State holiday, he or she shall make a written request for inspectional services during such period. If such a request is made and granted, the contractor shall notify the Contracting Officer not less than twenty-four (24) hours in advance of the time when the inspectional services are required. The contractor shall pay the Department at the rate per hour designated by the Department for each employee provided pursuant to this paragraph.

**D. Inspection of Plant or Site, Access to Plant or Place of Business.**

1. Inspection of plant or site. Circumstances under which the Department may perform inspections include, but are not limited to, inspections of the Contractor's plant or site in order to determine: Whether the standards set forth in section 3-122-108, Hawai'i Administrative Rules, have been met or are capable of being met; and if the contract is being performed in accordance with its terms. (HAR 3-122-166)
2. Access to plant or place of business. The Department may enter a Contractor's or subcontractor's plant or place of business to:
  - a. Inspect goods or services for acceptance by the Department pursuant to the terms of a contract;

- b. Audit cost or pricing data or audit the books and records of any Contractor or subcontractor pursuant to section 3-122-175, Hawai'i Administrative Rules; and
- c. Investigate in connection with an action to debar or suspend a person from consideration for award of contracts pursuant to sections 3.126-11 through 3-126-18, Hawai'i Administrative Rules. (3-122-167,8)

E. **Samples and Test Specimens.**

When required by the Contracting Officer, test specimens or samples of materials, equipment, instruments, pipes and fittings and other Waterworks appurtenances to be used or offered for use in the performance of the contract shall be prepared and furnished by the contractor in such quantities and sizes as may be required for proper examination and tests, with information as to their sources.

The contractor shall furnish additional test specimens and samples as directed.

Test specimens and samples shall be submitted in ample time to enable the Department to make such tests or examinations as may be necessary. Laboratory tests and examinations made in a laboratory other than that of the Department shall be at the expense of the contractor.

F. **Tests.**

Tests specified by the contract, statute, regulation, Water Standards, or ordinance shall be made; and the cost thereof shall be borne by the contractor unless otherwise provided for in such contract, statute, regulation or ordinance. Such tests shall be conducted under the direction of the Contracting Officer, and the contractor shall repair any damage resulting there from.

In addition, the Contracting Officer may require such tests as he or she deems necessary to carry out his or her duties during the performance of the work under the contract. When a test is required by the Contracting Officer, the contractor under the direction of the Contracting Officer shall conduct such test and shall bear all of the costs, including the cost of tools, labor and materials necessary therefor.

G. **Site Access.**

The contractor shall provide access to the work at all times to representatives of the Department of Federal Environmental Protection agency, the State of Hawai'i Water Pollution Control, State Department of Health, and any other authorized Federal, State or County Agencies whenever the work is in preparation or in the process, and shall provide proper facilities for such access and inspection. In addition, authorized representatives of the Department and the County shall have access to any books, documents, papers and records of the contractor which are pertinent to the project for the purpose of making audit, examinations, excerpts, and transactions thereof.

H. **Removal of Defective and Unauthorized Work.**

All work which has been rejected as not conforming to the requirements of the contract shall be remedied or removed and replaced by the Contractor in an

acceptable manner at no cost to the Board. Any work done beyond the work limits shown on the plans and specifications or established by the Contracting Officer, as authorized under the terms of the Contract, or any additional work done without written authority will be considered as unauthorized and will not be paid for. Work so done may be ordered removed at the Contractor's expense. Upon failure on the part of the Contractor to comply promptly with any order of the Contracting Officer made under the provisions of this subsection, the Contracting Officer shall have authority to cause defective work to be remedied or removed and replaced and unauthorized work to be removed and to deduct the costs from any monies due or to become due the Contractor.

## **6.10 PERSONAL SUPERVISION**

The contractor shall be present on site in person, or by a responsible agent with authority to act for the contractor in connection with the contract during the performance of the contract.

The contractor shall file with the Contracting Officer a written statement signed by the contractor giving the names of the designated competent person(s) for trench excavation and confined space entry, any and all supervisors, foreman and employees who are authorized to act in place of the contractor, and any communication signed in behalf of the contractor by such agents immediately and in writing of any change in the name or names so submitted.

## **6.11 CHARACTER OF WORKMEN, METHODS AND EQUIPMENT**

The Contractor shall at all times provide adequate supervision and sufficient labor and equipment for prosecuting the several classes of work to full completion of the project in the manner and within the time required by the contract.

- A. Character and Proficiency of Workers. All workers must have sufficient skill and experience to perform properly the work assigned to them. All workmen engaged in special work or skilled work such as bituminous courses of mixtures, concrete pavement or structures, electrical installation, plumbing installation, or in any trade shall have sufficient experience in such work and in the operation of the equipment required to properly and satisfactorily perform all work. All workers shall make due and proper effort to execute the work in the manner prescribed by the Contract; otherwise, the Contracting Officer may take action as prescribed herein. Any worker employed on the project by the Contractor or by any subcontractor who, in the opinion of the Contracting Officer, is not careful and competent, does not perform his work in a proper and skillful manner or is disrespectful, intemperate, disorderly or neglects or refuses to comply with directions given, or is otherwise objectionable shall at the written request of the Contracting Officer, be removed forthwith by the Contractor or subcontractor employing such worker and shall not be employed again in any portion of the work without the written consent of the Contracting Officer. Should the Contractor or subcontractor continue to employ, or again employ such person or persons on the project, the Contracting Officer may withhold all monthly payments which are or may become due, or the Contracting Officer may suspend the work until such orders are complied with, with no adjustment in contract end date being made.



- B. Insufficient Workers. In the event that the Contracting Officer, in his judgment, finds the condition whereby insufficient workers are present to accomplish the work and no corrective action is taken by the Contractor after being informed, the Contracting Officer reserves the right to terminate the contract as provided for under Section 8 REMEDIES.
- C. Equipment Requirements. All equipment furnished by the Contractor and used on the work shall be of such size and of such mechanical condition that the work can be prosecuted in an acceptable manner at a satisfactory rate of progress and the quality of work produced will be satisfactory.

Equipment used on any portion of the project shall be such that no injury to the work, adjacent property or other objects will result from its use. If the Contractor fails to provide adequate equipment for the work, the contract may be terminated as provided under Section 8 REMEDIES.

In the event that the Contractor is paid for furnishing and operating equipment on a force account basis, it shall be operated as directed by the Contracting Officer in order to obtain maximum production under the prevailing conditions.

## **6.12 WAGES AND HOURS**

Contractors shall observe and comply with all the provisions of Chapter 104, HRS, relating to wages and hours of employees on public works. The contractor shall pay all employees on any contract with the Department, the minimum basic wage rate in conformance with applicable Federal and State laws.

The minimum wages shall be periodically increased during the performance of a contract in an amount equal to the increase in the prevailing wages for those kinds of work as periodically determined by the State Director of Labor and Industrial Relations. Notwithstanding the provisions of the original contract entered into, if the Director of Labor and Industrial Relations determines that the prevailing wage has increased, the rate of pay of laborers and mechanics on the contract shall be raised accordingly. Offerors shall take into consideration increases which may occur during the period of the contract in computing their bid or proposal prices. No additional compensation shall be made for failure to do so.

The current State Wage Rate Schedule and any addenda is incorporated in this document by reference only. Copies are available the State Department of Labor and Industrial Relations, 830 Punchbowl Street, Honolulu, HI 96813, or at the State website:

<http://hawaii.gov/labor/rshttp://labor.hawaii.gov/wsd/files/2013/02/104-2FAQ-Rev-3-09.pdf>

No labor or mechanic employed on the job site shall be permitted or required to work on Saturday, Sunday, or a legal holiday of the State of Hawai'i in excess of eight (8) hours on any other day unless the laborer or mechanic receives overtime compensation for all hours worked on Saturday, Sunday, and a legal holiday of the State or in excess of eight (8) hours on any other day. For purposes of determining overtime compensation under this subsection, the basic hourly rate of any laborer or mechanic shall not be less than the basic

hourly rate determined by the Director of Labor and Industrial Relations to be the prevailing basic hourly rate for corresponding classes of laborer and mechanics on projects of similar character in the State.

A certified copy of all payrolls shall be submitted weekly to the Manager. The contractor shall be responsible for the submission of certified copies of the payrolls of all subcontractors. The certification shall affirm that the payrolls are correct and complete, that the wage rates contained therein are not less than the applicable rates contained in the wage determination decision of the Director of Labor and Industrial Relations attached to the contract, and that the classifications set forth for each laborer or mechanic conform with the work the laborer or mechanic performed.

If the Contracting Officer finds that any laborer or mechanic employed on the job site by the contractor or any subcontractor has been or is being paid wages at a rate less than the required rate by the contract or the specifications, or has not received the laborer's or mechanic's full overtime compensation, the Contracting Officer may take appropriate action in accordance with Section 104-4, HRS, or the Contracting Officer may, upon recommendation of the Contracting Officer, by written notice to the contractor, terminate the contractor's right, or the right of any subcontractor, to proceed with the work or with the part of the work in which the required wages or overtime compensation have not been paid and may complete such or part by contract or otherwise, and the contractor and the contractor's sureties shall be liable to the Department for any excess costs occasioned thereby.

The contractor is required to post the applicable wage schedule in a prominent and easily accessible place at the job site. The contractor shall give to each laborer and mechanic employed under the contract a copy of the rates of wages required to be posted.

On federally funded or federally assisted projects, the current federal wage rate determination in effect at the time of advertising for bids or proposals is incorporated as part of the invitation for bids or proposals, and both State and federal wage rates shall apply. Where rates for any class of laborers and mechanics differ, the higher rates shall prevail. The minimum federal wage rates shall be those in the U.S. Department of Labor Wage Determination Decision and Modifications in effect five (5) calendar days prior to the bid or proposal opening date.

### **6.13 CONTRACTOR'S ADDRESS**

The contractor shall provide and maintain a post office address within the State of Hawai'i and file the same with the Contracting Officer. Any written order or notice which may be required or desirable under the contract may be served on the contractor personally, or delivered to his or her representative on the project site, or left with a member of his or her family of suitable age and discretion at his or her residence, or with any employee of the contractor at his or her place of business and/or mailed to the aforesaid local post office address. All orders or notices shall become effective when mailed or at the time of service or delivery as aforesaid.

### **6.14 OBSTRUCTIONS**

The Contractor shall remove all obstructions, the removal of which shall be necessary for the proper reception, performance, construction, installation, and completion of all work under this contract, as called for or implied in the plans and specifications, and is considered incidental work.

#### **6.15 SURVEYS AND CONSTRUCTION STAKES, LINES AND GRADES**

All lines, levels and elevations are to be laid out and checked by a surveyor or civil engineer licensed in the State of Hawai'i at the contractor's expense. The contractor shall furnish a certificate or document signed by the surveyor or civil engineer certifying that the completed lines, levels and elevations are in conformity with the contract. The contractor shall verify all lines, levels and elevations indicated in the contract before any excavation or construction begins. Any discrepancy shall be immediately brought to the attention of the Manager and any change shall be made in accordance with his or her instruction. The contractor shall not be entitled to any additional payment if he or she fails to report the discrepancies before proceeding with work within the area affected by the discrepancies.

#### **6.16 SUBCONTRACTING**

The contractor shall not subcontract any part of the contract except to those subcontractors specifically listed in the bid or proposal submitted by the contractor; provided, however, the contractor may for good cause and upon written approval of the Contracting Officer engage other subcontractors. Engaging subcontractors to perform the work under the contract shall not relieve the contractor of his or her duty to perform the contract in accordance with the terms, covenants, conditions, provisions and intent thereof. The contractor shall replace a subcontractor when required by the Contracting Officer for not performing the contract in accordance with the terms, covenants, conditions, provisions and intent thereof.

#### **6.17 OTHER CONTRACTS**

The contractor shall coordinate his or her operations with those of other contractors who may be employed on adjacent or related projects of the State, County, Department or private development, shall avoid interference therewith, and shall cooperate with the other contractors so as to avoid unnecessary delay or hindrance in the performance of their respective contracts. Any difference or conflicts which may arise between the contractor and other contractors of the State, County, Department or private development in regard to their projects shall be adjusted and determined by the Department's staff, whose decision and order shall be final and binding.

#### **6.18 WATER REMOVAL**

The contractor shall examine the site of the project and make all necessary arrangements with affected property owners for the removal of water from the site. The contractor shall provide a bridge or other facilities to prevent water flowing into adjacent properties and adjacent streets as a result of his or her activities, from interfering with the traffic on such streets.

#### **6.19 ELECTRICAL, TELECOMMUNICATION AND WATER SERVICE**

The contractor shall make his or her own arrangements for electrical, telecommunication and water services required for the performance of the contract at his or her expense. The Contractor shall be responsible for scheduling and coordinating the work with the utility companies and applicable governmental agencies for temporary and permanent service connections. The Contractor will pay the utility companies and applicable governmental agencies directly for such connections upon receipt of the state of charges.

The contractor or subcontractor will not be charged for the final filling of any new or refurbished tank if a temporary hydrant meter is used. For example, a new or refurbished 0.5 MG Tank will be credited 500,000 gallons. All other usage of the temporary hydrant meter such as, but not limited to, testing of new waterlines, irrigation, and dust control will be charged to the contractor.

## **6.20 UTILITIES UNDERGROUND**

Prior to offer: All underground waterlines and appurtenances, gas, oil, telephone, television, electric, storm drain, fiber optic, sewer and other pipes or conduits, if shown on the plans, are only approximate in their locations. Prior to bid or proposal, the contractor shall make a personal investigation and inspection of the records of the owners of the utilities, supplemented by actual digging in the field, if necessary, to determine the actual locations of such utilities with all their branch and service lines whether indicated on the plans or not. Consequences resulting from the Contractor's failure to do so will be the sole cost and responsibility of the Contractor.

Prior to installation of new facilities: The contractor shall make satisfactory arrangements with the owners of the utilities for the relocation, maintenance and protection of existing utilities and shall furnish the Department's staff with evidence in writing that satisfactory arrangements have been made not less than ten (10) days before the commencement of the parts of the project under the contract affecting such utilities. Further, the Contractor shall probe the project area to verify existing utilities shown or not shown on the approved construction drawings and indicate potential conflicts with new facility installation. If required, the Department will consider redesign of the new facilities to deal with the potential conflicts. Consequences resulting from the Contractor's failure to do so will be the sole cost and responsibility of the Contractor.

## **6.21 QUALITY OF MATERIALS AND EQUIPMENT**

Unless otherwise specifically stated in the specifications, all workmanship, equipment, materials and articles incorporated in the work covered by this contract are to be of the best available grade of their respective kinds. Whenever specifications for any material, article, device, product, fixture, form, type of construction or process is indicated or specified by patent or proprietary name, by name of the manufacturer or by catalog number, such specifications shall be deemed to be used for the purpose of establishing a standard of quality and to facilitate the description of the material or process desired and shall be deemed to be followed by the words "or equal."

All materials and equipment furnished and installed under this contract shall be new and must be of standard quality of their respective kinds, free from all defects which may render them unfit for use. The contract contemplates the use of first-class materials and equipment

throughout the performance of the contract, and it is agreed that any material and equipment for which no particular specification is given shall be of the highest quality of its class or kind. The Manager will not accept materials and equipment that do not conform to the contract.

Rejected materials and equipment shall be removed immediately from the work and replaced with materials and equipment of the required quality. Should the contractor fail to remove such rejected materials and equipment within twenty-four (24) hours after notice by the Contracting Officer, the latter may remove such rejected materials and equipment and deduct the expense therefor from any sum due or to become due the contractor. Failure to reject any material and equipment or to remove any rejected material and equipment shall not relieve the contractor from responsibility as to the quality and character of materials and equipment used or as to any other obligation imposed upon him by the contract.

## **6.22 NATIONAL SANITATION FOUNDATION (NSF) APPROVALS**

All materials used in Waterworks construction (pipe, pipe lubricants, paints, sealants, form oil, concrete admixtures, etc.) in direct contact with the potable water shall be approved by the National Sanitation Foundation (NSF). The contractor shall submit these approvals to the Contracting Officer for review and approval prior to its application.

## **6.23 SAMPLES**

Whenever requested by the Contracting Officer, the contractor shall furnish samples of materials to be used in the performance of the contract. Said samples if approved, will be retained by the Contracting Officer and, subject to his or her order, shall be used as the standard with which all like materials furnished under the contract must conform. The approval of any sample tested by the Contracting Officer or his or her failure to require the furnishing of samples shall not relieve the contractor from performing the work in accordance with the contract.

## **6.24 PROTECTION OF PEDESTRIANS AND VEHICULAR TRAFFIC**

During the progress of the work, the contractor shall use all proper precautions and methods of procedure and construction by means of good and sufficient barriers, guards, temporary bridges, notices, lights, warning and other safeguards for the prevention of accidents and for the protection of persons and property, and from sunset until sunrise he or she shall keep suitable lights burning wherever the public has access near or at the work in progress to define the line of safe passage. The Contractor shall defend, indemnify and save harmless the Department and Board against any and all suits, actions and claims for cost, compensation, damages or otherwise to which the said Department may be put on account of injury to person or property of another, resulting from negligence of the contractor in the performance of the work or the guarding of the same; and he or she shall include in his or her bond such terms as will protect the Department and Board against any loss, charge or expense by reason of any such claims, suits or actions.

### **A. Public Convenience.**

The contractor shall so conduct his or her operations as to offer the least possible obstruction and inconvenience to the public and he or she shall have under

construction no greater length or amount of work than he or she can prosecute properly with due regard to the rights of the public.

Unless otherwise provided in the special provisions, all public traffic shall be permitted to pass through the work with as little inconvenience and delay as possible.

Spillage resulting from hauling operations along or across any public travel way shall be removed immediately by the contractor at his or her expense.

Construction operations shall be conducted in such a manner as to cause as little inconvenience as possible to abutting property owners.

Convenient access to driveways, houses, mail boxes and buildings along the line of the work shall be maintained and temporary approaches to crossings or intersecting highways shall be provided and kept in good condition.

Water or dust palliative shall be applied if ordered by the Manager for the alleviation or prevention of dust nuisance at all times, regardless of whether or not work is being performed on the site.

**B. Public Safety**

The contractor shall comply with all requirements and provisions of the Federal, State and County safety laws, including Hawai'i Occupational Safety and Health (OSHA) Laws, and all building and construction codes, and shall take all necessary precautions for the safety of all employees on the project.

Wherever the contractor's operations create a condition hazardous to traffic or to the public, he or she shall furnish, erect and maintain, at his or her expense and without cost to the Department, such fences, barricades, lights, signs and other devices as are necessary to prevent accidents or damage or injury to the public.

Should the contractor appear to be neglectful or negligent in furnishing warning and protective measures as above provided, the Contracting Officer may direct attention to the existence of a hazard and the necessary warning and protective measures shall be furnished and installed by the contractor at his or her expense.

Should the Contracting Officer point out the inadequacy of warning and protective measures, such action on the part of the Contracting Officer shall not relieve the contractor from responsibility for public safety or abrogate his or her obligation to furnish and pay for these devices.

The installation of general roadway illumination shall not relieve the contractor of his or her responsibility for furnishing and maintaining any of the protective facilities hereinbefore specified.

**C. Accidents.**

The contractor must promptly report in writing to the Manager all accidents whatsoever arising out of or in connection with the performance of the work,

whether on or adjacent to the site which caused death, personal injury or property damage, giving full details and statements of witnesses. In addition, if death or serious injuries or serious damage is caused, the accident shall be reported immediately by telephone or by messenger to the Manager.

If any claim is made by anyone against the contractor or any subcontractor on account of any accident, the contractor shall promptly report the facts in writing to the Manager, giving full details of the claim. It is understood and agreed that the written report of any accident shall not relieve the contractor of the responsibility, and the Department and Board shall not be held responsible.

D. **Non-compliance.**

The Manager will notify the contractor of any non-compliance with the foregoing provisions and the action to be taken. If the contractor fails or refuses to comply promptly, the Contracting Officer, with the approval of the Contracting Officer, may issue an order stopping all or part of the work until satisfactory corrective action has been taken. No extension of time or payment for excess costs or damage shall be made for the time lost due to such stop action.

If no corrective action is taken by the contractor within twenty-four (24) hours after a suspension is ordered by the Contracting Officer, the Department reserves the right to take whatever action is necessary to correct the situation and to deduct all costs incurred by the Department in taking such action from moneys due the contractor.

The Contracting Officer may also suspend any operations which he or she feels are creating safety problems. The Department's failure to act pursuant to this section shall not be considered a liability and failure on the Department's part to act shall not be considered a waiver to any rights and remedies to which the Department is entitled.

## **6.25 ACCESS TO PROPERTY**

The contractor shall provide safe access to the property abutting the site of the project when the usual means of access are obstructed by the performance of the contract.

## **6.26 PROJECT SIGN**

The contractor shall provide signs to identify the project. The signs shall be erected at locations designated by the Contracting Officer at the site of the project upon commencement of the work under the contract. Signs shall be properly erected and kept clean and legible. After completion of the work under the contract and final acceptance thereof, the contractor shall remove the signs.

The Contractor shall assume all responsibilities in maintaining the sign in good legible condition and free from any damage during the entire construction period, and shall make good all such repairs at no cost to the Department.

## **6.27 PROJECT MAY BE PLACED IN SERVICE**

The Department may place parts of the project in service as completed and the contractor shall give proper access to such portions for this purpose. Use of the portions so placed in service by the public shall constitute an acceptance by the Department of such portions of the project involved but shall not constitute total completion nor shall it constitute final acceptance . The Department does not recognize the concept of substantial completion to avoid liquidated damages.

## **6.28 PRECAUTIONS AND RESTORATION**

The contractor shall protect property adjacent to the site of the project from damage and shall restore property damaged by him to the condition it was in prior to the damage. Prior to starting any work, the contractor shall photograph and video the existing conditions of structures, landscaping, etc. that are to remain within the project and any staging areas. Any existing defects, damages, etc. shall be noted and forwarded in writing to the Department of Water. Any damage to existing items noted during or after completion of the project that were not specifically reported in writing prior to starting any work shall be repaired and replaced by the contractor at no cost to the Department.

### **A. Existing Utilities and Structures.**

The existence and location of underground utilities and structures as shown on the plans are from the latest available data but are not guaranteed as to their actual existence or location. Other obstacles not shown on the plans may be encountered in the course of the work.

The contractor shall make a personal investigation and inspection of the records of the owners of the utilities, supplemented by actual digging in the field if necessary to determine the actual locations of such utilities with all their branch and service lines whether indicated on the plans or not. The contractor shall furnish the Manager with written evidence that the contractor has contacted all the utility companies.

The contractor shall be held responsible for any damage to and for the maintenance and protection of existing utilities and structures whether shown on the plans or not.

The contractor shall also completely protect all buildings, pavements, gutters, curbs, sidewalks, driveways, walls, fences, pipes, drains, conduits, or other structures of all classes, nature or types from settlement or other damage by installing proper underpinning, sheet piling and bracing and by taking all proper precautions during the period of construction. The contractor shall be responsible for the settlement of any pavement, building or any other structure of any class, nature or type caused by the dewatering of trenches or from any other cause relative to the work of the contractor and he or she shall in all cases be held liable for any damage to any building, structure or property along the line of the work.

Should it become necessary to remove, replace, obstruct, alter or use any existing pipe, hydrant, conduit, pole or other equipment or structure of any kind, the contractor shall make all necessary arrangements with the Department, State, County, corporation, company or any other organization owning or controlling the same relative to the removal, replacement, obstruction, alteration, use, damage and the payment therefor and shall furnish the Contracting Officer with evidence in



writing that satisfactory arrangements have been made, not less than ten (10) calendar days before removing, replacing, altering, using or obstructing the equipment or structure concerned.

B. **De-watering.**

De-watering shall be accomplished by suitable means; this includes the Contractor obtaining the required NPDES permits for de-watering. The contractor shall repair any and all damages resulting to improvements from such de-watering operation to the satisfaction of the owners of such improvements.

C. **Grass.**

When grassed areas are disturbed, the area shall be carefully graded and replanted with similar grass placed not over 6"x 6" center to center, leaving the area substantially similar to the condition it was in prior to the excavation.

D. **Trees, Plants and Shrubbery.**

All trees shall be carefully protected and kept from contact with excavation or other materials. Where it is necessary to trim trees, plants or shrubs, the contractor shall employ licensed tree trimmers. Branches shall be carefully trimmed so that the trees, plants or shrubs are not damaged. All cut sections of branches shall be painted with tree seal compound. All grass, plants, trees or shrubs removed or destroyed shall be replaced by the contractor to the satisfaction of the Department, corporation, company or any other organization owning or controlling the area where this work is to be done. All costs thereof shall be considered incidental.

E. **Property Marks.**

The contractor shall reference and replace marks, stakes, pipes, monuments of the property line and similar objects which may be disturbed by the contractor while performing the contract.

F. **Environmental Pollution Control.**

The contractor shall comply with the following requirements for pollution control in performing all construction activities. The contractor shall be responsible for conformance to all federal, state and county laws regarding environmental pollution control, including Chapters 37 and 37-A the Public Health Regulations, Department of Health, State of Hawai'i, as amended, during construction.

1. **Erosion and Sediment Control.**

- a. Soil protection facilities shall be completed as early as practicable. Sections of bare earth and the length of their exposure to erosion shall be minimized by proper scheduling and limiting the work areas. Temporary berms, cut-off ditches, and other provisions which may be required because of the contractor's method of operation shall be installed at no cost to the Department. Also, the contractor shall continue such measures until establishing the protective ground cover sufficiently to be an effective erosion deterrent. If material begins to erode into a river, stream or impoundment, the contractor shall act immediately to bring the situation under control.

Surface drainage from cuts and fills within the construction limits and from borrow and waste disposal areas shall, if turbidity producing materials are present, be held in suitable sedimentation ponds or shall be graded to control erosion within acceptable limits.

The contractor shall restrict construction operations in rivers, streams, lakes and reservoirs where channel changes are shown in the contract. Also, the contractor shall restrict construction operations to those areas that are entered for the construction of temporary or permanent structures. The contractor shall clear rivers, streams, lakes and reservoirs promptly of water pipes, fittings, false work, piling, drill cuttings, debris, or other obstructions.

The contractor shall not deposit excavated material in or near rivers, streams, lakes and reservoirs and shall at all times comply with the Federal Clean Water Act, 33 U.S.C. §1251 et seq. and any other applicable laws.

The contractor shall not permit fording of streams with construction equipment. The contractor shall use temporary bridges or other structures wherever stream crossings are necessary. The contractor shall not operate mechanized equipment in streams except to construct channel changes and temporary or permanent structures. The contractor shall avoid or minimize interferences with the movement of migratory fish.

2. Landscape Preservation, Forest and Well Source and Water Facilities Protection.

The contractor shall conform to Federal, State and County laws, statutes, ordinances, rules and regulations, including the Department of Water and Fire Department, State Department of Land & Natural Resources governing the protection of forests, well sources and water sheds, and the performance of work in these areas.

The contractor shall keep the project area in an orderly condition, dispose refuse, and obtain permits for the construction and maintenance of Department's water facilities and appurtenances according to the State Forester requirements.

The contractor shall take precaution and assist in preventing and suppressing forest fires. The contractor shall notify a Forest official of the location and amount of fire.

The contractor shall avoid or minimize disturbance to game preserves, water sheds and operations of the State Forester and Department of Water.

3. Waste Disposal.

a. Care shall be exercised to insure that disposal of waste from construction operations do not create pollution problems.

- b. Disposal of any materials, waste, effluent, trash, garbage, oil, grease, chemicals, etc., in areas adjacent to streams shall be subject to the approval of the Manager.
- c. No burning of debris and/or waste materials shall be permitted on the project site.
- d. No burying of debris and waste materials except for materials which are specifically indicated elsewhere in the bid or proposal document as suitable for backfill shall be permitted on the project site.
- e. All unusable debris and waste materials shall be hauled away to an appropriate off-site dump area. During loading operations, debris and waste materials shall be watered down to allay dust.
- f. Frequency of cleanup shall coincide with rubbish producing events.

4. Dust Control.

Dust, which could damage crops, orchards, cultivated fields, Department's water facilities, public and private facilities, business establishments and dwellings or cause nuisance to persons, shall be abated and control measures shall be performed at all times, including non-working hours, weekends and holidays. The cost for all dust control sprinkling shall be paid for by the contractor and shall extend for the entire period of construction. The contractor shall be held liable for any damage resulting from dust originating from his or her operations.

5. Waste Water.

Construction operations shall be conducted so as to prevent discharge or accidental spillage of construction water, pollutants, solid waste, debris and other objectionable wastes in surface waters and underground water sources.

6. National Pollutant Discharge Elimination System (NPDES) Permit and other Water Discharge Permits.

The contractor shall review and become familiar with the latest requirements of the NPDES Permit as issued by the State Health Department and all other necessary permits to discharge water into the waterways prior to bidding or proposing on this project. All inquiries for this permit shall be coordinated with the State Health Department.

Immediately after the award of the construction contract, the contractor shall meet with the Contracting Officer to complete the applications for a Department of Health NPDES Permit and for all other permits that may be required to discharge water into waterways. The Contractor shall be the duly authorized representative of the Department of Water as it relates to NPDES requirements.

Notice to proceed will not be delayed due to the contractor's inability to

meet NPDES Permit requirements in a timely manner.

See Exhibit N for Best Management Practices (BMP) inspection report to be used during construction as NPDES permit compliance verification. The BMP report shall be submitted on a weekly basis to the Contracting Officer.

7. Noise Control.

The Department of Health's Chapter II-46, Hawai'i Administrative Rules, Community Noise Control, establishes statewide noise rules on community noise.

This statewide noise rule complies with Chapter 342F, Hawai'i Revised Statutes, which states that the Director of Health shall present, control and abate noise pollution in the state.

In reference to construction activities, community noise permit applications are required for construction operations which exceed, or are anticipated to exceed noise standards established in the rules. The significance of the community noise permit is to allow for construction operations to exceed the noise standards, while allowing the Department of Health to monitor such activities to assure adequate protection of public health and welfare from adverse noise impacts.

The following activities related to construction operations are exempt from the provisions of the rules:

- a. Activities related to the emergency maintenance and repair of state and county highways, parks, and public utilities including but not limited to water, sewer, electric, gas, and telephone systems, provided the noise is confined to only the equipment in use.
- b. Backup alarm devices on any vehicle, where such device is required by federal or state occupational safety and health regulations.
- c. Construction and remedial activities related to the emergency repair of damages caused by natural disasters, including but not limited to tsunamis and hurricanes.

The contractor shall be responsible to obtain all permits and provide the Manager with a copy. The contractor shall pay for all applicable permit fees.

8. Others

- a. Whenever trucks and/or vehicles leave the site and enter surrounding paved streets, the contractor shall prevent any materials from being carried onto the pavements.
- b. Trucks hauling debris shall be covered as required by PUC regulations. Truck hauling fine materials shall be covered.

- c. No dumping of waste concrete will be permitted at the job site unless otherwise permitted in the Special Provisions.
- d. Except for rinsing of the hopper and deliver chute, and for wheel washing where required, concrete trucks shall not be cleaned on the job site.
- e. Except in an emergency, such as mechanical breakdown, all vehicle fueling and maintenance shall be done in designated areas. A temporary berm shall be constructed around the area when runoff can cause problems.
- f. Spray painting will not be allowed unless done by the “airless spray” process.

9. Payment

The cost of environmental pollution control shall not be considered incidental and shall be included in the price of offer for the various items of work.

G. Archaeological, Historical, and Burial Site Findings

Whenever the contractor encounters possible archaeological, historical or burial site findings, the contractor shall immediately suspend the operation and inform the Contracting Officer verbally and follow up with a written letter. The Contracting Officer will notify the proper authorities to evaluate such findings and decide the course of action.

The contractor shall not resume suspended operations without the prior written acceptance of the Manager. Delays resulting from the discovery, investigation, and handling of such findings shall extend the completion date. The Contracting Officer will govern suspensions of work according to subsection 8.3 of these General Provisions. Also, the contractor shall conform to Chapter 6E, H.R.S. relating to Historic Preservation, as amended.

Construction work and equipment shall remain within the right-of-way limits of this project.

The Archaeologist will decide the limits of the site. Also, the Archaeologist will decide, with the Manager, the best means for protecting the site from further disturbances which requires further investigation or salvage as determined by the State Historic Preservation Officer. Protection may include barricades, roping off, temporary fencing or other means.

H. Protection of Fish and Wildlife

The contractor shall at all times perform all work and take such steps to prevent any interference or disturbance to fish and wildlife. The Contractor shall be solely liable for any fees or costs associated with failure to take the proper and necessary steps to prevent such interference and agrees to defend, indemnify, and hold harmless the

Department from any actions arising out of the failure to take the proper and necessary steps to prevent such interference to fish and wildlife.

I. **Subcontractors**

Compliance with the provisions of this subsection by the subcontractors will be the responsibility of the contractor.

J. **Health and Safety Compliance**

1. **Safety Program.** The Contractor shall comply with chapter 396, HRS, relating to the standards of occupational safety and health and all applicable Federal, State and County laws and regulations, including but not limited to section 396-18, HRS, relating to safety and health programs for contractors for Department construction projects where the proposal amount is in excess of \$100,000.

2. **Responsibility.** The Contractor shall designate a responsible member of its organization at the site whose duty shall be the prevention of accidents. This person shall be the Contractor's superintendent unless otherwise designated by the Contractor in writing to the Contracting Officer.

3. **Safeguards, Signs.** The Contractor shall erect and maintain, as required by existing conditions and performance of the contract, reasonable safeguards for safety and protection, including posting danger signs and other warnings against hazards, promulgating safety regulations and notifying owners and users of adjacent sites and utilities.

4. **No Loading.** The Contractor shall not load or permit any part of the construction or site to be loaded so as to endanger its safety.

5. **Emergency.** In an emergency affecting safety of persons or property, the Contractor shall act, at its discretion, to prevent threatened damage, injury or loss. The Contractor shall notify the Contracting Officer in writing of such emergency and remedial steps taken as soon as reasonably feasible. Additional compensation or extension of time claimed by the Contractor on account of an emergency may be considered by the Department.

K. **Non-compliance**

The Contracting Officer will notify the contractor of any non-compliance with the foregoing provisions and the action to be taken. If the contractor fails or refuses to comply promptly, the Contracting Officer, with the approval of the Contracting Officer, may issue an order stopping all or part of the work until satisfactory corrective action has been taken. No extension of time or payment for excess costs or damage shall be made for the time lost due to such stop action.

If no corrective action is taken by the contractor within forty-eight (48) hours after a suspension is ordered by the Contracting Officer, the Department reserves the right to take whatever action is necessary to correct the situation and to deduct all costs incurred by the Department in taking such action from moneys due the contractor.

The Contracting Officer may also suspend any operations which he or she feels are creating pollution problems although they may not be in violation of the above-mentioned requirements. In this instance, the work shall be done by Force Account as described in Modification and Force Account provisions herein. The count of

elapsed working days to be charged against the contract in this situation shall be determined by the Contracting Officer upon recommendation of the Manager.

## **6.29 MAINTENANCE OF SITE, CONTROL OF DUST, AND FINAL CLEANUP**

The contractor shall maintain the site of the project in an orderly and clean condition, and shall at suitable intervals and/or at the direction of the Manager, remove accumulations of rubbish or refuse materials, surplus Waterworks materials, concrete mortar, excavated materials and drill cuttings not required or suitable for backfill. Chlorinated water shall not be deposited in the drainage or sewer system of the County of Kaua'i. The contractor shall keep the site, inclusive of vehicular and pedestrian traffic routes through the site, free of dirt, and dust by periodic blading, power brooming, watering or other approve means to the satisfaction of the Manager.

Upon completion and before final acceptance of the work performed under the contract, the contractor shall remove excavated materials, drill cuttings, rubbish, surplus or discarded Waterworks materials, false work, forms, temporary structures, field offices, project signs, signs not a part of the project, and his or her equipment and machinery, and shall leave the site and ground occupied by him in connection with the performance of the contract in an orderly and clean condition. Waterworks facilities constructed, altered, or worked in by the contractor in the performance of the contract shall be left "broom clean," and stains and other blemishes resulting from his or her operations, such as dropped or splattered concrete or mortar and paints, grease or oil, shall be removed from floors, walls, ceiling, windows, Waterworks equipment, pipes, instruments and all other exposed surfaces. All applicable items in section 6.28 shall be completed during final cleanup within the project area. Failure to do so will be grounds for denying final acceptance of the project work and withholding final payment.

## **6.30 RESPONSIBILITY OF THE CONTRACTOR PRIOR TO ACCEPTANCE**

The contractor shall repair, reconstruct, restore and replace the work or any part thereof which is injured or damaged, whatever cause, prior to acceptance of the work by the Manager.

Use by the public without permission of the Department shall not in any way be construed as an acceptance of the work under the contract and shall not in any way relieve the contractor from his or her obligation under the contract. Use of parts of the project completed under the contract by the public with the approval of the Department shall constitute acceptance of such portion of such work by the Department but shall in no way be construed to relieve the Contractor from his or her remaining obligations under the contract and shall in no way be construed as final acceptance of the project as a whole. Use of parts of the project shall not prevent accrual of liquidated damages as laid out in the contract.

Final inspection will be given when all items laid out in the plans, specifications, addendum, punch list and any and all other contract documents are completed. If the Department provides the Contractor with a pre-final punch list of items, final inspection approval will not be given until those items are completed to the satisfaction of the Department. If applicable, failure to attain final approval and/or final acceptance of the

project will result in the accrual of liquidated damages.

All completed facilities that are damaged by the contractor or by his or her negligence to safeguard the facilities from construction activities shall be repaired by the contractor to the satisfaction of the Department or applicable agencies.

In case of suspension in the performance of the work under the contract from any cause whatsoever, the contractor in addition to being responsible for performing the work under the contract shall:

- A. Defend indemnify and save the Department and its officers and employees harmless from liability for any injury or damage occurring during the period that the performance of the contract is suspended.
- B. Be responsible for all materials and equipment delivered to the site of the project, including materials and equipment for which he or she has received partial payment.
- C. Properly store the materials and equipment which have been partially paid for by the Department or which have been furnished by the Department.
- D. Remove immediately as directed by the Contracting Officer all surplus materials, equipment and rubbish.
- E. Neatly and compactly store, only with the approval of the Contracting Officer, all materials and equipment on the site of projects that are not within public highways or streets.
- F. Provide suitable drainage and erect such temporary structures as are necessary to protect the project or parts of the project from damage, and damages to the Department personnel and public.

### **6.31 FINAL INSPECTION**

The Contracting Officer shall make final inspection with representatives of other County or State agencies interested in the contract within seven (7) calendar days after the work performed under the contract is completed and the site of such work has been cleaned as provided in subsections 6.29 and 6.30. The completed project as-built plans shall contain items required in Exhibit M and shall be submitted to the Contracting Officer at the time of final inspection.

### **6.32 FINAL COMPLETION AND FINAL ACCEPTANCE**

Final Completion is defined as when the work is fully completed and in accordance with the Contract Documents, including, without limitation, satisfaction of all punch list items.

In order to obtain a determination of Final Completion, Contractor shall notify the Contracting Officer in writing when the project is complete with no deficiencies and ready for Final Inspection.



Final inspection will be given when all items laid out in the plans, specifications, addendum, punch list and any and all other contract documents are completed. If the Contracting Officer provides the Contractor with a pre-final punch list(s) of items, Final Inspection will not be given until those items are completed to the satisfaction of the Contracting Officer. Final Inspection will be completed in accordance with section 6.31 above.

Final Acceptance is defined as obtaining a designation of Final Completion of the Work and submittal of all necessary documents, including where applicable, but not limited to the following:

1. All written warranties required by the contract.
2. All required "As-Built" drawings.
3. Complete weekly payrolls for both the General and Subcontractors.
4. Certificate of all applicable building permit inspections.
5. Final Report for Specialty Inspections.
6. Certificate of building occupancy as required.
7. Certificate of Soil and Wood Treatments.
8. Certificate of Water System Chlorination.
9. Certificate of Elevator Inspection, Boiler and Pressure Pipe installation.
10. Maintenance Service Contract and two (2) copies of a list of all equipment installed.
11. All operating and maintenance manuals for installed equipment and all associate training to be complete.
12. All other documents required by the Contract.

The Final Acceptance Date shall determine:

1. End of Contract time.
2. Commencement of all warranty periods.
3. Commencement of all maintenance services required in per the Contract.

Failure to attain Final Acceptance of the project will result in the accrual of liquidated damages in accordance with the Contract Documents.

Upon determination of Final Completion, the Contracting Officer will send written notification to the Contractor of the Final Acceptance Date via a Final Inspection of Water Facilities approval letter.

### **6.33 GUARANTEE OF WORK**

- A. All work shall be guaranteed by the Contractor against defects resulting from the use of defective or inferior materials, equipment or workmanship for one year or as otherwise noted in the technical specifications from the date of Final Acceptance of the contract.
- B. If, within any guarantee period, repairs or changes are required in connection with the guaranteed work, which in the opinion of the OIC is rendered necessary as a result of the use of materials, equipment or workmanship which are inferior, defective or not in accordance with the terms of the contract, the Contractor shall within five (5) consecutive working days and without expense to the County commence to:
  - 1. Place in satisfactory condition in every instance all of such guarantee work and correct all defects therein; and
  - 2. Make good all damages to the building or work or equipment or contents thereof.
- C. Whenever a warranty on any product hereinafter specified exceeds one (1) year, this warranty shall become part of this contract thereof. The Contractor shall complete the warranty forms in the name of the County and submit such forms to the manufacturer within such time required to validate the warranty.

### **6.34 CLOSING CONTRACTS**

In order to close a contract, the Contractor shall submit the final payment request and the applicable closing documents by the specified time. In the event that the Contractor should fail to comply with this request, the Contracting Officer may terminate the Contract. The pertinent provisions of **Section 8 REMEDIES** shall be applicable.

## SECTION 7 - PAYMENT

### 7.1 PAYMENT

The contractor shall receive and accept the compensation provided in the contract as full payment for the performance of the contract.

For lump sum contracts, the contract price shall be the result obtained by first reducing the amount designated as the total sum bid or proposal in the award by the amount included therein for allowances and contingencies and adding thereto or deducting therefrom any extra cost or any reduction in cost, respectively, to the Department as a result of supplemental agreements in writing and written orders of the Contracting Officer pursuant to subsection 5.3.

For unit price contracts, the contract price shall be the sum results obtained by multiplying the number of units of such item(s) incorporated in the work under the contract by the unit price therefor. The unit price of an item shall be the amount therefor specified in the bid or proposal, provided that if the number of units of any item needed to perform the required work exceeds or is less than the number specified in the bid or proposal as the Department's estimate of quantity of units required by more than fifteen percent (15%), then a price adjustment shall be made in the unit price for the item by supplemental agreement or, at the option of the Contracting Officer, by first determining the cost of the item on the basis of a Force Account pursuant to subsection 7.4 and dividing the cost by the number of units of the item needed to perform the required work. (Auth: 3-125-10, HAR)

### 7.2 VARIATIONS IN ESTIMATED QUANTITIES

The quantities of the items in the offer form are approximate only, and the Department reserves the right to increase or decrease any of the quantities as the Contracting Officer shall deem necessary or advisable.

A. **Variations Requiring Adjustments.**

Where the quantity of a pay item in this contract is an estimated quantity and where the actual quantity of such pay item varies more than fifteen percent (15%) above or below the estimated quantity stated in this contract, an adjustment in the contract price shall be made upon demand of either party. The adjustment shall be based upon any increase or decrease in costs due solely to the variation above one-hundred fifteen percent (115%) or below eighty-five percent (85%) of the estimated quantity. If the quantity variation is such as to cause an increase in the time necessary for completion, the Contracting Officer shall, upon receipt of a timely written request for an extension of time, prior to the date of final settlement of the contract, ascertain the facts and make such adjustment for extending the completion date as in the judgment of the Contracting Officer the findings justify.

B. **Adjustment in Price.**

Any adjustment in contract price made pursuant to the paragraph immediately above shall be determined according to the price adjustment clause of this contract. (Auth: 3-125-10, HAR)

### 7.3 QUANTITIES AND MEASUREMENTS

All quantities of work to be completed under the contract shall be measured by the Contracting Officer. The contractor shall inform the Contracting Officer when measurements are required. These measurements shall be considered correct and final unless the contractor files a written protest demonstrating the existence of an error within ten (10) calendar days after receipt of such measurement data.

Quantities or measurements indicated in the bid or proposal, if any are given for the convenience of the contractor. It will be assumed that the lump sum bid or proposal and unit prices made by the contractor and the price agreed upon by him are based on a thorough knowledge of the existing conditions and the amount and kind of work to be performed. It is expressly understood and agreed by the contractor that quantities and measurements of the work to be done and the materials to be furnished under this contract which have been estimated, as given are approximate. The contractor further agrees and hereby understands that neither the Manager, Contracting Officer, the Department nor any of their representatives is to be held responsible if such estimated quantities and measurements shall not be found to be the same or even close to the actual quantities and measurements required for the work under the contract. The contractor will make no claim for anticipated profits, or for loss of profits because of a difference between the quantities or measurements of the work actually done, or of materials actually delivered, and the estimated quantities or measurements stated in the bid or proposal. If an error, omission or mis-statement shall be discovered in the quantities or measurements stated in the bid or proposal, the same shall not vitiate the contract, or release the contractor or his or her surety or sureties from performing the contract, or affect the price agreed to under the contract, or excuse the contractor from any of the obligations or liabilities under the contract, or entitle him to damages or compensation, except as provided herein.

### 7.4 FORCE ACCOUNT

In Force Account, the Department will pay for work done according to the following items:

A. **Labor.**

The contractor will receive the wage rate including fringe benefits for actual work engaged by the worker. Fringe benefits are the required amounts by collective bargaining agreement or other employment contract generally applicable to the classes of labor employed. The contractor shall submit the fringe benefits for each class in writing to the Manager for acceptance before the Force Account work begins. The contractor may include foremen when authorized by the Manager.

The Department will pay the contractor an amount equal to thirty-five percent (35%) of the actual labor cost to cover the contractor's and subcontractor's operating expense, indirect and direct overhead and profit.

The Manager will not allow for overtime compensation without the written acceptance of the Manager before performance of that work. For authorized overtime, the Manager will pay one and a half (1-1/2) times the hourly wage rate plus the actual hours of overtime for fringe benefits, and/or as required by collective bargaining agreement.

B. **Insurance and Tax.**

The contractor will receive the projected average rate for the required insurance and taxes including property damage, liability, worker's compensation insurance premiums, State unemployment contributions, Federal unemployment taxes and social security taxes, average tax rate and Medicare taxes. The Manager will add six percent (6%) to the insurance and tax.

The contractor shall submit the projected average rate for taxes and insurance premium for the applicable current year for acceptance by the Manager.

C. **Material.**

The contractor shall receive the actual cost of that material including transportation charges accepted by the Manager, delivered, and incorporated into the work. The Manager will add fifteen percent (15%) to the material cost to cover operating expense, direct overhead, and profit.

D. **Equipment.**

1. Machinery and equipment shall be in good working condition and suitable for the purpose for which the contractor plans to use the machinery and equipment. The Manager may reject any machinery which he or she deems unnecessary, inefficient or inadequate for the work to be performed under Force Account.

2. Individual pieces of equipment or tools having replacement value of two hundred dollars (\$200.00) or less are small tools. The Department will not make payments for small tools.

3. **Rental Rate.**

a. The Department will pay the rental rates at the per-hour rates by dividing the monthly rate for that machinery or equipment by one hundred seventy-six (176). These rental rates are in the "Rental Rate Blue Book for Construction Equipment Volume I" (Rental Blue Book). The Manager will use the edition for the period doing work. The rental rate includes the estimated operating cost per hour and the regional correction factor. The Manager shall review and accept the equipment for use.

b. If the Rental Blue Book does not have the particular type of equipment, the Manager and the contractor shall agree on the rates in writing before its use. This includes rental rates for contractor-owned trucks.

c. For trucks not owned by the contractor, the Hawai'i State Public Utilities Commission shall establish the rental rate. The Department will pay for these as a material item according to Sub-section 7.4.c.

d. The Department may allow rental rates that are higher than the "Rental Blue Book." The contractor will submit a request for such

higher rates in writing for acceptance before using such equipment.

- e. Rental rates include the cost of fuel, oil, lubricant, supplies, attachments, repairs, maintenance, tire wear, depreciation, and storage.
  - f. Rental rates for idle time.
    - i. Idle time is the time period in which the machinery and/or equipment designated for a specific Force Account work is not in use for the work. The time period shall be for a working day (8 hours).
    - ii. The Manager will pay for fifty percent (50%) of the monthly hourly rate excluding the estimated operational cost per hour per working day.
  - g. Rental rates for stand-by time.
    - i. Stand-by time is the time period in which the machinery and equipment are standing by for the specific Force Account work day. A work day shall not exceed eight (8) hours (stand-by time plus the operating time) unless the Manager authorizes the overtime.
    - ii. The Manager will pay at the monthly hourly rate including the estimated operational cost per hour per working day.
  - h. The Manager will pay for authorized overtime for each hour over the normal eight (8) hours shift work day, legal holidays, Saturdays, and Sundays.
4. The Department will only pay for hours worked. The Department will not pay for equipment due to breakdowns.
5. Less than thirty (30) minutes of operation is half (1/2) hour of operation.
6. The cost of transporting the equipment shall not exceed the rates established by PUC. If such rates are non-existent, the Manager will resolve the rates based on the rates charged by established haulers within the State.
7. Payment.
- a. Equipment on the Project Site.
    - i. The rental time shall be the time the equipment is in operation on the Force Account work. Also, the rental time includes the time required to move the equipment to the location of the Force Account and to return the equipment to the original location or to another location requiring no more

time than to return the equipment to its original location. If the contractor uses the equipment at the site of the Force Account work on other than such Force Account work, the Manager will not pay for moving time. Moving time will be paid at the monthly hourly rate including the estimated operational rate and the applicable regional correctional factor.

- ii. When moving the equipment by other than its own power, the Manager will allow loading and transporting costs instead of moving time. If the contractor uses the equipment at the site of the Force Account work on other than such Force Account work, the Manager will not pay for moving time.

Payment for the transporter, if owned by the contractor shall be on the monthly hourly rate including the estimated operational rate and the applicable regional correction factor. Payment for the transporter, if not owned by the contractor, shall be by invoice cost and paid under “material.”

The Manager will pay for the equipment at the rate of “idle time.”

b. Equipment Not on the Project Site.

- i. The Manager shall confirm the location from which the equipment is to move or transport.
- ii. If the contractor transports the equipment to the site for the exclusive use of the Force Account work, the Department will pay the cost of mobilizing and transporting the equipment from its original location to the site of the Force Account work. This includes loading and unloading. Also, the Manager will pay the cost of demobilizing and transporting the equipment back to its original location or to another location, whichever cost is less.
- iii. For self-propelled equipment, the Department will pay the cost of moving the equipment by its own power from its original location to the site of the Force Account work. Also, the Department will pay the cost of moving the equipment back to its original location or to another location, whichever cost is less.

The Manager will pay for the equipment at the monthly hourly rate including the estimated operational rate and the applicable regional correction factor.

The Manager will pay for the contractor-owned escort for the

self-propelled equipment at the monthly hourly rate including the estimated operational rate and the applicable regional correction factor. The Manager will pay for escort not owned by the contractor under material with an invoice.

- iv. If the contractor desires the return of the equipment to another location, the Department will pay the cost of transportation according to the above provisions, provided such payment does not exceed the cost of moving the equipment to the project site.
- v. If the contractor uses the equipment on the project site in ways other than on Force Account work, the Department will pay the cost of transporting the equipment to the job site. The contractor shall bear the cost of returning the equipment.
- vi. The Manager will begin the rental period at the time the equipment is unloaded at the site of work or at the time specified, whichever is later. The Manager will include each day that the machinery or equipment is at the site of the Force Account work. The rental period will terminate when the Manager orders the contractor to discontinue the use of the machinery or equipment.
- vii. If the equipment goes on stand-by because of delays in design, traffic, or other related problems uncontrollable by the contractor, the rental rate and rental period will be at the monthly hourly rate of not more than eight (8) hours per day.
- viii. If the equipment goes “idle” from the event of the previous work day, the Manager will make the rental rate and rental period under “idle time” excluding Saturdays, Sundays, and legal holidays until the Manager orders the contractor to discontinue or demobilize the machinery or equipment.

E. **Subcontracting.**

The contractor shall receive an additional amount equal to five percent (5%) of the total cost of that work computed as set forth above when the accepted subcontractors work on a Force Account basis.

F. **Bond.**

The Manager will add a bond allowance of one percent (1%) to the total sum determined in (A) through (E).

G. **State Excise Tax.**

The Manager will add a State Excise Tax (4.166%) to the total sum determined in (A) through (F) as stated in HRS 237.

The contractor shall consider the compensation as determined in (A), (B), (C), (D),



(E), (F), and (G) above to be payment in full for work done on a Force Account basis, including superintendence, overhead, use of non-rental tools and equipment, profit, taxes and subcontracting.

H. **Records.**

The authorized representative of the contractor and the authorized representative of the Manager shall verify and sign the Force Account worksheet each day for work done on a Force Account basis. These records shall be the basis for payment of the Force Account work.

I. **Statements.**

The Manager will not make payment for work done on a Force Account basis until the contractor submits duplicate, itemized statements of the cost of that Force Account work, as authorized by the Manager, and:

1. Title. Contract number, its name or with the subcontractor's name, date, project title, contract change order number, project number, item number and item description.
2. Labor. Name of worker, classification, quantity of workers, daily hours, unit, rate of pay, extension of each worker, the fringe benefits amount payable if there are fringe benefits, and the extension for its operating expense, overhead and profit.
3. Insurance Rate - Average Tax. Cost for property damage, liability, workmen's compensation insurance premiums, average tax rate of State unemployment contributions, Federal unemployment taxes and social security taxes.
4. Materials. Description of the material, quantity of material, prices, extensions, cost of transporting materials, wholesale tax, and the extension for its operating expense, overhead, and profit. Include the cost of transporting materials only if the prices of the materials do not reflect that cost.
5. Equipment. Equipment classification, quantity of equipment, daily hours, unit, rental rate, extension for each unit of machinery and equipment.
6. The contractor shall type or write the description of work done for the day. The contractor shall have an authorized representative sign the two (2) copies. The authorized representative will initial the copies if the signatures are from a copy machine.

The contractor shall accompany and support the statements by invoices for transportation charges and materials used. If materials used on the Force Account work are not specifically purchased for such work but the contractor took the material from its stock, the Manager may request verification of material payment instead of invoices. The contractor shall submit an affidavit certifying that:

- a. The contractor took such materials from his or her stock,
  - b. The contractor used the quantity claimed used, and
  - c. The price and transportation claimed represent the actual cost.
7. The Manager may make payments of the Force Account work individually by labor, materials and equipment with the compliance of each item.

## **7.5 PAYMENTS DURING PERFORMANCE OF WORK**

The Contracting Officer, prior to the commencement of work under the contract will submit to the Contractor a schedule of values of the various parts of the work, including quantities, aggregating the total sum of the contract, made out in such form as the Contracting Officer and the contractor may agree upon, and, if required, supported by such evidence as to its correctness as the Contracting Officer, may direct. The schedule, as approved by the Contracting Officer, shall be used as a basis for payment under the contract.

The Contractor shall, not later than the last day of each month during the performance of the contract, make an estimate of the amount of work done in accordance with the contract during that month, deducting sufficient allowance for incomplete or unprotected work or to provide for any contingency for known defects or known damage to said work or for the necessity of performing any part of the work over again to cure such defects or damage.

The Department will retain five percent (5%) of the amount due under the contract to the contractor to insure the proper performance of the contract. After fifty percent (50%) of the contract is completed and progress of work is satisfactory, no additional sums for retainage shall be withheld. However, if progress of work is not satisfactory, the Department may continue to withhold as retainage, sums not exceeding five percent (5%) of the amount due the contractor. The Department will hold the retainage amount until completion, in an acceptable manner of all the work as indicated in the Plans and Specifications. The monthly estimate as ascertained hereinabove, less the retainage and previous payments, will be certified and paid to the contractor. The monthly estimates must be accompanied by an updated full performance schedule per section 6.2 and Hawai'i Residency Act 103B Compliance Form.

## **7.6 PAYMENT FOR DELIVERED MATERIALS**

Unless the contractor submits a paid invoice for the materials, the Department will not make payment for materials under this subsection.

The Department may pay the contractor:

- A. The cost of accepted material to be incorporated in the work, and
- B. When the contractor delivers such materials to the project and stored in acceptable storage places near the project.

Also, the Department may pay the contractor:

- A. For cost of accepted materials furnished and acceptably stored in a fabricator's yard provided such storage yard is on Kaua'i and
- B. If the contractor furnishes evidence that the materials are for use on the project. The contractor shall not use that material elsewhere.

The Department will not exceed the bid or proposal price of that item for payments authorized in this subsection. The contractor shall not consider payment of the material as final acceptance. The contractor shall be responsible for those materials.

Payment for material does not relieve the contractor of his or her obligations to furnish material acceptable to the Manager and to incorporate properly the material into the project according to the contract.

The Department will not make material payment on living or perishable plant material.

## 7.7 FINAL INSPECTION - FINAL PAYMENT

After completion of all the work required under the contract and Final Acceptance, as defined in Section 6.32 thereof by the Contracting Officer, the contractor will be paid the balance due in accordance with the Manager's final estimate of the construction actually performed, provided that final payment will be made only with the approval of the Contracting Officer, and the written consent to the surety or sureties on the contractor's bond after receipt of a Tax Clearance certificate from the Director of Taxation of the State of Hawai'i and Internal Revenue Service as provided in Section 103-53, HRS, as amended, and certification from the Department that any and all outstanding bills of the Contractor and subcontractors due and owing to the Department are paid.

## 7.8 PROMPT PAYMENT BY CONTRACTORS TO SUBCONTRACTORS

### A. Prompt Payment Clause

1. **Generally.** Any money paid to a contractor shall be disbursed to subcontractors within ten (10) days after receipt of the money in accordance with the terms of the subcontract; provided that the subcontractor has met all the terms and conditions of the subcontract and there are no bona fide disputes on which the procurement agency has withheld payment.
2. **Final payment.** Upon final payment to the contractor, full payment to the subcontractor, including retainage, shall be made within ten days after receipt of the money; provided that there are no bona fide disputes over the subcontractor's performance under the subcontract.
3. **Penalty.** The Contracting Officer or the contractor, as applicable, will be subject to a penalty of one and one-half percent (1.5%) per month upon outstanding amounts due that were not timely paid by the responsible

party under the following conditions. Where a subcontractor has provided evidence to the contractor of satisfactorily completing all work under their subcontract and has provided a properly documented final payment request as described in paragraph (4) herein, and:

a. Has provided to the contractor an acceptable performance and payment bond for the project executed by a surety company authorized to do business in the State, as provided in section 103-32.1, HRS; or

b. The following has occurred:

i. A period of ninety (90) days after the day on which the last of the labor was done or performed and the last of the material was furnished or supplied has elapsed without written notice of a claim given to contractor and the surety, as provided for in section 103D-324, HRS; and

ii. The subcontractor has provided to the contractor, an acceptable release of retainage bond, executed by a surety company authorized to do business in the State, in an amount of not more than two (2) times the amount being retained or withheld by the contractor; any other bond acceptable to the contractor; or any other form of mutually acceptable collateral, then, all sums retained or withheld from a subcontractor and otherwise due to the subcontractor for satisfactory performance under the subcontract shall be paid by the Contracting Officer to the contractor and subsequently, upon receipt from the Contracting Officer, by the contractor to the subcontractor within the applicable time periods specified in paragraph (2) herein and section 103-10, HRS. The penalty may be withheld from future payment due to the contractor, if the contractor was the responsible party. If a contractor has violated paragraph (2) herein three (3) or more times within two (2) years of the first violation, the contractor shall be referred by the Contracting Officer to the contractors license board for action under section 444-17(14), HRS.

4. A properly documented final payment request from a subcontractor, as required by paragraph (3) herein, shall include:

a. Substantiation of the amounts requested;

b. A certification by the subcontractor, to the best of the subcontractor's knowledge and belief, that:

- i. The amounts requested are only for performance in accordance with the specifications, terms, and conditions of the subcontract;
  - ii. The subcontractor has made payments due to its subcontractors and suppliers from previous payments received under the subcontract and will make timely payments from the proceeds of the payment covered by the certification, in accordance with their subcontract agreements and the requirements of this section; and
  - iii. The payment request does not include any amounts that the subcontractor intends to withhold or retain from a subcontractor or supplier in accordance with the terms and conditions of their subcontract; and
- c. The submission of documentation confirming that all other terms and conditions required under the subcontract agreement have been fully satisfied.

The Contracting Officer shall return any final payment request that is defective to the contractor within seven (7) days after receipt, with a statement identifying the defect.

5. In the case of a construction contract, a payment request made by a contractor to the Contracting Officer that includes a request for sums that were withheld or retained from a subcontractor and are due to a subcontractor may not be approved under paragraph (3) herein unless the payment request includes :
- a. Substantiation of the amounts requested; and
  - b. A certification by the contractor, to the best of the contractor's knowledge and belief, that:
    - i. The amounts requested are only for performance in accordance with the specifications, terms, and conditions of the contract;
    - ii. The subcontractor has made payments due to its subcontractors and suppliers from previous payments received under the contract and will make timely payments from the proceeds of the payment covered by the certification, in accordance with their subcontract agreements and the requirements of this section; and
    - iii. The payment request does not include any amounts that the contractor intends to withhold or retain from a

subcontractor or supplier in accordance with the terms and conditions of their subcontract.

The Contracting Officer shall return any final payment request that is defective to the contractor within seven (7) days after receipt, with a statement identifying the defect.

6. This section shall not be construed to impair the right of a contractor or a subcontractor at any tier to negotiate and to include in their respective subcontracts provisions that provide for additional terms and conditions that are requested to be met before the subcontractor shall be entitled to receive final payment under paragraph (3) herein; provided that any such payments withheld shall be withheld by the Contracting Officer. (HAR 3-125-23)

## **SECTION 8 - REMEDIES**

### **8.1 DISPUTES**

- A. The resolution of controversies or claims, by mutual agreement, in excess of \$50,000 shall be subject to prior written approval of the Manager. (HAR 3-126-27)
- B. All controversies between the Department and the contractor not exceeding \$50,000 which arise under, or are by virtue of, this contract and which are not resolved by mutual agreement, shall be decided by the Manager in writing, within ninety (90) calendar days after a written request by the contractor for a final decision concerning the controversy. For claims exceeding \$50,000, a decision will be issued ninety (90) calendar days after receipt of a written claim; provided that if a decision is not issued within ninety (90) calendar days, the Manager will notify the Contractor of the time within which such decision will be made. This additional time period will depend on the size and complexity of the claim and the adequacy of the Contractor's supporting data and other relevant factors. If the Manager does not issue a written decision within the specified time period, then the contractor may proceed as if an adverse decision has been received.
- C. All controversies involving claims asserted by the Department against the contractor which cannot be resolved by mutual agreement shall be the subject of a decision by the Manager.

The Manager shall immediately furnish a copy of the decision to the contractor, by certified mail, return receipt requested, or by any other method that provides evidence of receipt.

- D. Any such decision shall be final and conclusive, unless fraudulent, or unless the contractor brings an action seeking judicial review of the decision in the Fifth Circuit Court of the State of Hawai'i within six (6) months from the date of receipt of the decision.
- E. The contractor shall comply with any decision of the Manager and proceed diligently with performance of this contract pending final resolution by the Fifth Circuit Court of the State of Hawai'i of any controversy arising under, or by virtue of, this contract, except where there has been a material breach of contract by the Department; provided that in any event the contractor shall proceed diligently with the performance of the contract where the Manager has made a written determination that continuation of work under the contract is essential to the public health and safety. (Auth: 3-126-31, HAR)
- F. If a reduction in cost or extra cost to the Department is the result of a written order of the Manager pursuant to subsection 5.3 and/or 5.4 cannot be agreed, the amount of such cost shall be determined on the basis of a Force Account pursuant to subsection 7.4.

### **8.2 CLAIMS BASED ON ORAL DIRECTIVES**

Not more than five (5) days after receipt of the written notice from the contractor that the contractor intends to treat an oral directive as a change order (in accordance with Section 5.3 herein), the Contracting Officer shall issue a change order for the subject work if the Contracting Officer agrees that it constitutes a change. If no change order is issued in the time established, it shall be deemed a rejection of contractor's claim for a change. If the contractor objects to the Contracting Officer refusal to issue a change order, it shall file a written protest with the Manager within thirty days after delivery to the Manager of the contractor's written notice of its intention to treat the oral order as a change. In all cases, the contractor shall proceed with the work. The protest shall be determined as provided in the disputes and claims section of the contract. (Auth: 3-125-16, HAR)

### **8.3 DEFAULT, DELAY AND TIME EXTENSIONS**

A. **Default.**

If the contractor refuses or fails to perform the work, or any separable part thereof, with such diligence as will assure its completion within the time specified in this contract, or any extension thereof, fails to complete the work within such time, or commits any other substantial breach of this contract, and further fails within seven (7) days after receipt of written notice from the Contracting Officer to commence and continue correction of the refusal or failure with diligence and promptness, the Contracting Officer may, by written notice to the contractor, declare the contractor in breach and terminate the contractor's right to proceed with the work or the part of the work as to which there has been delay or other breach of contract. In the event, the Department may take over the work and perform the same to completion, by contract or otherwise, and may take possession of, and utilize in completing the work, the materials, appliances, and plants as may be on the site of the work and necessary therefore. Whether or not the contractor's right to proceed with the work is terminated, the contractor and the contractor's sureties shall be liable for any damage to the Department resulting from the contractor's refusal or failure to complete the work within the specified time.

B. **Liquidated damages upon termination.**

If fixed and agreed liquidated damages are provided in the contract, and if the Department so terminates the contractor's right to proceed, the resulting damage will consist of the liquidated damages for the time as may be required for final completion of the work.

C. **Liquidated damages in absence of termination.**

If fixed and agreed, liquidated damages are provided in the contract, and if the Department does not terminate the contractor's right to proceed, the resulting damage will consist of such liquidated damages until the contractor's work is completed and final acceptance given by the Department per section 6.32.



D. **Time extension.**

The contractor's right to proceed shall not be so terminated nor the contractor charged with resulting damage if:

1. The delay in the completion of the work arises from causes beyond the Contractor's control such as: acts of God; acts of the public enemy; acts of the Department, County, State and any other governmental entity in either a sovereign or contractual capacity; acts of another contractor in the performance of a contract with the Department; fires; floods; epidemics; quarantine restrictions; strikes or other labor disputes; freight embargoes; unusually severe weather; delays of subcontractors due to causes similar to those set forth above; or shortage of materials; provided, however, that no extension of time will be granted for a delay caused by the failure on the part of the contractor and/or subcontractor to diligently perform his or her duties as it relates to any governmental agency in a timely manner; provided further, however, that no extension of time will be granted for a delay caused by a shortage of materials, unless the contractor furnishes to the Manager proof that the contractor has diligently made every effort to obtain such materials from all known sources, and further proof that the inability to obtain the materials when originally planned did in fact cause a delay in final completion of the entire work which could not be compensated for by revising the sequence of the contractor's operations; and
2. The contractor, within ten (10) calendar days from the beginning of any such delay (unless the Contracting Officer grants a further period of time before the date of final payment under the contract), notifies the Contracting Officer in writing of the causes of delay. The Contracting Officer shall ascertain the facts and the extent of the delay and extend the time for completing the work when, in the judgment of the Contracting Officer, the findings of fact justify such an extension.

The following is required in writing when notifying the Contracting Officer of any such delay:

- A. Justification/narrative
- B. Supporting documentation
  - i. RFI's, change orders, letters/notices
- C. Description of impact (list of affected activities)
- D. Time analysis impact to be included.

The Contracting Officer shall have twenty (20) working days to approve or deny such request.

3. Rainout days are not covered by items 1 and 2 above. All rainout days shall be requested by the contractor to the Contracting Officer on the same calendar day of the rainout. Failure by the contractor to make the request within the day of the rainout shall be grounds for denial of the rainout for that particular calendar day.

The following is required in writing when notifying the Contracting Officer of any such delay:

- A. Justification/narrative
- B. Description of impact (list of affected activities)
- C. Time analysis impact to be included.

The Contracting Officer shall have twenty (20) working days to approve or deny such request.

- E. **Any additional rights and remedies.** The rights and remedies of the Department provided in this claim are in addition to any other rights and remedies provided by law or under this contract.

#### **8.4 SUSPENSION OF WORK**

- A. The Contracting Officer may by written order, suspend the performance of the work, either in whole or in part for such periods as the Manager may deem necessary for any cause, including but not limited to:
  - 1. Weather or soil conditions considered unsuitable for prosecution of the work;
  - 2. Failure on the part of the contractor to:
    - a. Correct conditions unsafe for the general public or for the workers;
    - b. Carry out orders given by the Manager;
    - c. Perform the work in strict compliance with the provisions of the contract; or
    - d. Provide adequate supervision on the jobsite.
  - 3. Whenever a redesign that may affect the work is deemed necessary by the Contracting Officer;
  - 4. Unacceptable noise or dust arising from the construction even if it does not violate any law or regulation; or
  - 5. The convenience of the Department.
- B. Suspension of work on some but not all items of work shall be considered a “partial suspension”. Suspension of work on all items shall be considered “total suspension”. The period of suspension shall be computed from the date set out in the written order for work to cease until the date of the order for work to resume.
- C. In the event that the contractor is ordered by the Contracting Officer in writing as provided herein to suspend all work under the contract in accordance with the above paragraphs 3, 4, or 5, the contractor may be reimbursed for actual money expended towards the project during the period of suspension. No allowance will be made for anticipated profits.

- D. If the performance of all or any part of the work is, suspended, for reasons beyond the control of the contractor, an adjustment shall be made for any increase in the cost of performance of this contract (excluding profit) necessarily caused by such suspension, and the contract modified in writing accordingly. However, no adjustment shall be made under this clause for any suspension:
1. To the extent that performance would have been so suspended, delayed, or interrupted by any other cause, including the fault or negligence of the contractor; or
  2. For which an adjustment is provided for or excluded under any other provisions of the contract.
- E. Claims for adjustment. Any adjustment in contract price made pursuant to this clause shall be determined in accordance with the provisions on changes and claims for adjustment. Claims for the compensation shall be filed in writing with the Manager within thirty days after the date of the order to resume work or the claims will not be considered. Together with the claim, the contractor shall submit substantiating documents covering the entire amount shown on the claim. The Manager shall take the claim under consideration and may make such investigations as are deemed necessary. The Contracting Officer shall be the sole judge as to the equitability of the claim and the Contracting Officer's decision shall be final.
- F. No adjustment. No provision of this subsection shall entitle the contractor to any adjustments for delays due to failure of surety, for suspensions made at the request of the contractor, for any delay required under the contract, for suspensions, either partial or whole, made by the Manager under the provisions in subparagraph A2. (Auth: 3-125-7, HAR)

## **8.5 TERMINATION OF CONTRACT - WORK MAY BE TAKEN OVER BY DEPARTMENT**

The Department may terminate the contract, or require the work therein to be completed by the surety or sureties under the contractor's bond or take over such work as hereinafter provided without terminating the contract, if the contractor:

- A. fails to begin work under the contract at the time required,
- B. is unnecessarily delaying the performance of the contract or any part thereof,
- C. is failing to perform the contract with sufficient or adequate workmen, equipment or materials or is not making sufficient progress to ensure the completion of the contract within the time specified,
- D. fails to perform the contract in accordance with directions of the Manager,
- E. discontinues performance of the contract,

- F. fails to re-commence performance of the contract within a reasonable time after service of a written order to do so if the performance had been suspended,
- G. becomes insolvent or is declared bankrupt,
- H. commits any act of bankruptcy or insolvency,
- I. allows any final judgment to stand against him unsatisfied for a period of ten (10) days,
- J. makes an assignment for the benefit of creditors,
- K. fails to pay for all labor, tools, materials, and equipment,
- L. has been or is paying wages to any laborer or mechanic employed on the job site at a rate below the minimum rate specified in the contract,
- M. has failed to pay full compensation for overtime work by any such laborer or mechanic,
- N. has abandoned the performance of the contract,
- O. has made unjustifiable and substantive changes from the condition set forth in his or her original itemized bid or proposal,
- P. or violates or fails to perform the contract in accordance with the terms, covenants, conditions, provisions and intent thereof.

Whenever the Contracting Officer is not satisfied with the performance of the contract the Contracting Officer, with the approval of the Contracting Officer, may make specified orders as to the progress or conduct of such work, giving the contractor a definite period within which to comply with such orders; or whenever the contractor shall be in default in any particular requirement, the Contracting Officer, with the approval of the Contracting Officer Manager, shall serve the contractor, or its authorized representatives, with a written notice to remedy said default or any part thereof within fourteen (14) calendar days after notice thereof, serving copies of such notice to the surety or sureties of the contractor, as the case may be. If, after the expiration of the time of such notice, the contractor fails to comply with the notice, or the default continues, the Contracting Officer, with the approval of the Contracting Officer Manager, may order all payment under the contract to cease and the work to be discontinued. Upon such order the contractor shall discontinue the work. Failure on the part of the Department to order a discontinuance of the work or payment for the same shall in no event be construed as an acceptance of the work, nor as a waiver of any failure or any default. (Auth: 3-125-16, HAR [generally]).

Immediately upon or after ordering the contractor to discontinue the work, the Contracting Officer Manager may require the completion of the contract by the surety or sureties upon the contractor's bond, or (without prejudice to the Department to rely upon said bond), the Department's contract to a second contractor or contractors, or may direct DOW employees to enter upon the work and to use such materials, tools and equipment as he or she may find

upon the work and to procure labor, additional tools, materials and equipment for the completion of the work, and to complete said work in such a manner as he or she may deem advisable, and in such event the cost or expenses of completing the work and the delay resulting therefrom shall be a charge against the contractor and/or surety or sureties.

## 8.6 TERMINATION FOR CONVENIENCE

- A. Terminations. In addition to any other reason specified in subsection 8.5 above, the Contracting Officer may, with approval of the Manager, when the interests of the Department so require, terminate this contract in whole or in part, for the convenience of the Department. The Contracting Officer shall give written notice of the termination to the contractor specifying the part of the contract terminated and when termination becomes effective.
- B. Contractor's obligations. The contractor shall incur no further obligations in connection with the terminated work and on the date set in the notice of termination the contractor will stop work to the extent specified. The contractor shall also terminate outstanding orders and subcontracts as they relate to the terminated work. The contractor shall settle the liabilities and claims arising out of the termination of subcontracts and orders connected with the terminated work subject to the Department's approval. The Contracting Officer, upon recommendation by the Manager, may direct the contractor to assign the contractor's right, title, and interest under terminated orders or subcontracts to the Department. The contractor must still complete the work not terminated by the notice of termination and may incur obligations as necessary to do so.
- C. Right to construction and goods. The Contracting Officer may, upon recommendation by the Manager, require the contractor to transfer title and deliver to the Department in the manner and to the extent directed by the Contracting Officer:
1. Any completed constructions; and
  2. The partially completed construction, books, materials, parts, tools, dies, jigs, fixtures, plans, drawings, information, and contract rights (hereinafter called "construction material") as the contractor has specifically produced or specially acquired for the performance of the terminated part of this contract.

The contractor shall protect and preserve property in the possession of the contractor in which the Department has an interest. If the Contracting Officer does not exercise this right, the contractor shall use best efforts to sell the construction, goods, and construction materials in accordance with the standards of section 490:2-706, HRS. This in no way implies that the Department has breached the contract by exercise of the termination for convenience clause.

- D. Compensation.
1. The contractor shall submit a termination claim specifying the amounts due because of the termination for convenience together with cost or pricing data, submitted to the extent required by subchapter 15, chapter 3-122, HAR,

bearing on such claim. If the contractor fails to file a termination claim within one (1) year from the effective date of termination, the Contracting Officer, upon recommendation of the Manager, may pay the contractor, if at all, an amount set in accordance with subparagraph 8.6D3(b) of this subsection.

2. The Contracting Officer, upon recommendation of the Manager, and the contractor may agree to a settlement provided the contractor has filed a termination claim supported by cost or pricing data submitted as required and that the settlement does not exceed the total contract price plus settlement costs reduced by payments previously made by the Department, the proceeds of any sales of construction, goods, and construction materials under subparagraph 8.6D3(c), and the contract price of the work not terminated.
3. Absent complete agreement under paragraph 8.6D2 of this subsection, the Contracting Officer, upon notice from the Manager, shall pay the contractor the following amounts, provided payments under paragraph 8.6D2 of this subsection shall not duplicate payments under this paragraph the total (without duplication of any items) of:
  - a. The cost of all contract work performed prior to the effective date of the notice of termination work plus a five percent (5%) markup on actual direct costs on the portion of the work (the markup shall not include anticipatory profit or consequential damages) less amounts paid or to be paid for completed portions of the work; provided, however, that if it appears that the contractor would have sustained a loss if the entire contract would have been completed, no markup shall be allowed or included and the amount of compensation shall be reduced to reflect the anticipated rate of loss;
  - b. Subject to the prior approval of the Contracting Officer, the costs of settling and paying claims arising out of the termination of subcontracts or orders pursuant to “contractor’s obligations” provisions of this contract. Subcontractors shall be entitled to a markup of no more than ten percent (10%) on direct costs incurred to the date of termination.

These costs must not include costs paid in accordance with clause 8.6D3a.;
  - c. The total sum to be paid the contractor under this paragraph shall not exceed the total contract price reduced by the amount of any sales of construction, goods, and construction materials under subsection 8.3C, and the contract price of work not terminated.
4. Cost claimed, agreed to, or established under paragraphs 8.3D2 and 8.3D3 of this subsection shall be in accordance with chapter 3-123, HAR

## **8.7 COSTS OF COMPLETING CONTRACT**

The contractor and/or his or her surety or sureties shall pay the Department for all costs incurred to complete the work under the contract if the Department takes the work out of the hands of the contractor pursuant to the provisions of Subsection 8.5, and for damages for any delay in the performance of the contract.

## **8.8 DAMAGES FOR DELAY**

### **A. Liquidated Damages.**

The amount of damage to the Department as a result of failure to complete the work under the contract within the time fixed or any extension thereof, exclusive of overhead expenses, being certain but difficult, if not impossible, to ascertain, the contractor agrees to pay the sum stated in the contract as liquidated damages, and not by way of penalty, for every day of delay until the work under the contract is completed and accepted, or a reasonable time has expired for completion and acceptance of the portion of the contract remaining to be performed if the Department takes the work under the contract out of the hands of the contractor.

## **8.9 DAMAGES FOR EXTRA EXPENSES IMPOSED ON DEPARTMENT**

The contractor shall pay the Department for all the expenses incurred in re-doing any of the Department's obligations under the contract due to any actions or conduct of the contractor, including the replacing of marks or stakes set by the Manager.

## **8.10 DEFECTIVE WORK**

Any defective work, workmanship or materials that may be discovered in the performance of the contract before its acceptance or within one (1) year thereafter as provided in the performance bond, shall be replaced by the contractor with work and materials that conform to the contract at no cost or expense to the Department. The fact that the Manager may have overlooked defective work during the performance of the contract shall not constitute the acceptance of the same. No payment, whether partial or final, shall be construed to be an acceptance of any defective work, workmanship or materials in the work performed under the contract.

The Contracting Officer may at any time, stop the performance of the contract or any portion thereof which is not being done in accordance with a contract by written order. Such order shall not in any way relieve the contractor from performing the contract and shall not in any way terminate, cancel or abrogate the contract or any part thereof; and the Department shall not in any way be responsible for the delay due to stopping the performance of the contract or any portion thereof as aforesaid.

The Contractor shall provide a warranty on the project work for one year after final inspection date as reflected in the final inspection letter.

## **8.11 UNAUTHORIZED PERFORMANCE**

Performance of any work beyond the lines and grades shown on the plans or established by

the Contracting Officer or performance of any extra work without written order will be considered as unauthorized and will not be paid for. The Contracting Officer may require the removal of such work by service of a written order upon the contractor. If the contractor fails to comply promptly with such order, the Department shall remove such work and the contractor shall pay the Department for all expenses incurred in the removal of such work.

## **8.12 AUTHORITY TO WITHHOLD MONEY DUE OR PAYABLE**

The Department may withhold such amounts from the money due or to become payable under the contract to the contractor, or any assignee under subsection 5.6, as may be necessary to:

- A. Protect the Department from any liability resulting from the work performed under this contract;
- B. Satisfy any obligation of the contractor or its subcontractors to the Department, including obligations not relating to the contract, and the obligation of the contractor to the workmen, subcontractors, and materialmen who have performed labor or furnished material and equipment under the contract as provided by law; and
- C. Repair, restore, or compensate for, any real or personal property located within the project site or in the vicinity thereof which has been damaged as a result of the fault or negligence of the contractor while performing the work under this contract; provided that the estimated amount of damages for each separate property shall not be in excess of five hundred dollars (\$500.00).

The Department may make such payments from such amounts withheld as may be necessary to cause the repair or restoration of the damaged properties or to compensate therefor, to discharge such obligation as provided under paragraph B above, and to protect the Department from any liability resulting from the work performed under this contract; provided, however, before making any payment for damages to property prescribed in paragraph C above, the Department through the Manager shall request the contractor in writing to undertake the repair or restoration of the damaged property or make compensation therefor. If the contractor fails or refuses to make such repair, restoration or compensation to the satisfaction of the Manager within thirty (30) calendar days after such notification, the Department may make the necessary payments.

## **8.13 SPECIAL EMERGENCY TERMINATION**

In the event of a finding by the Manager and approved by the Contracting Officer that a national emergency exists which creates a shortage of materials, labor, or equipment and that such emergency will probably continue to exist for an indefinite length of time, or that funds are no longer available to the Department by reason of which the contractor will be unable to perform the work under the contract, the Department may cancel all remaining work required to be performed under the contract by written order.

Upon such cancellation, the Department shall pay the contractor the amount hereinafter provided. For lump sum contracts, an agreed upon price for the performance of the contract up to the time of cancellation, or at the option of the Manager, a price for such performance



determined on the basis of a Force Account pursuant to subsection 7.4. For unit price contracts, the sum of the results obtained by multiplying the number of units of each item incorporated into the parts of the project performed under the contract up to the time of cancellation by the unit price therefor. For both lump sum and unit price contracts, the contractor shall also be paid for such expenditures as in the judgment of the Manager are not otherwise compensated for and are require in the preparation and moving of equipment and materials to the site of the project, the intent being that an equitable settlement shall be made with the contractor. No claim for loss of anticipated profits, however, shall be made or considered.

Materials obtained by the contractor for the project, that have been inspected, tested, and accepted by the Manager, and that are not incorporated in the work under the contract, and which have been properly stored and maintained, will be purchased from the contractor at actual cost as shown by receipted bills or other proper evidence of actual cost at such points of delivery as may be designated by the Manager.

#### **8.14 REMEDIES NOT EXCLUSIVE**

The express provision herein of certain measures which may be exercised by the Department for its protection shall not be construed to preclude the Department from exercising any other or further legal or equitable right to protect its interest.

#### **8.15 REMEDIES**

Any dispute arising under or out of this solicitation or contract is subject to chapter 3-126, HAR. (Auth: 3-125-24, HAR)

APPROVED:

  
\_\_\_\_\_  
Manager & Chief Engineer

May 19, 2016  
Date

**EXHIBIT A – SURETY [BID][PROPOSAL] BOND**

**SURETY [BID] [PROPOSAL] BOND**  
(11/15/11)

Bond No. \_\_\_\_\_

**KNOW TO ALL BY THESE PRESENTS:**

That we,

\_\_\_\_\_  
(full name or legal title of offeror)

as Offeror, hereinafter called Principal, and

\_\_\_\_\_  
(name of bonding company)

as Surety, hereinafter called Surety, a corporation authorized to transact business as a Surety in the State of Hawai‘i, are held and firmly bound unto the Department of Water, County of Kaua‘i, as Owner, hereinafter called the Owner, in the penal sum of

\_\_\_\_\_  
(required amount of bid/proposal security)

Dollars (\$ \_\_\_\_\_), lawful money of the United States of America, for the payment of which sum well and truly to be made, the said Principal and the said Surety bind ourselves, our heirs, executors, administrators, successors and assigns, jointly and severally, firmly by these presents.

**WHEREAS:**

The Principal has submitted an offer for \_\_\_\_\_

\_\_\_\_\_  
(project by number and brief description)

**NOW, THEREFORE:**

The condition of this obligation is such that if the Department of Water, County of Kaua‘i, shall reject said offer, or in the alternate, accept the offer of the Principal and the Principal shall enter into a Contract with the Department of Water, County of Kaua‘i, in accordance with the terms of such offer, and give such bond or bonds as may be specified in the solicitation or Contract Documents with good and sufficient surety for the faithful performance of such Contract and for the prompt payment of labor and material furnished in the prosecution thereof as specified in the solicitation then this obligation shall be null and void, otherwise to remain in full force and effect.

Signed this \_\_\_\_\_ day of \_\_\_\_\_, 20\_\_\_\_.

(Seal)

\_\_\_\_\_  
Name of Principal (Offeror)

\_\_\_\_\_  
Signature

\_\_\_\_\_  
Title  
(Seal)

\_\_\_\_\_  
Name of Surety

\_\_\_\_\_  
Signature

\_\_\_\_\_  
Title

SURETY [BID] [PROPOSAL] BOND (EXHIBIT A)

# EXHIBIT B – PERFORMANCE BOND (SURETY)

## PERFORMANCE BOND (SURETY) (11/15/11)

### KNOW TO ALL BY THESE PRESENTS:

That

\_\_\_\_\_  
(full legal name and street address of Contractor)

as Contractor, hereinafter called the Principal, and

\_\_\_\_\_  
(name and street address of bonding company)

as Surety, hereinafter called Surety, a corporation(s) authorized to transact business as a Surety in the State of Hawai'i, are held and firmly bound unto the Department of Water, County of Kauai, its successors and assigns, hereinafter called Obligee, in the amount of

\_\_\_\_\_  
Dollars (\$ \_\_\_\_\_), to which payment Principal and Surety bind themselves, their heirs, executors, administrators, successors and assigns, jointly and severally, firmly by these presents.

**WHEREAS**, the above-bound Principal has signed a Contract with Obligee

\_\_\_\_\_, for the following project:

\_\_\_\_\_  
hereinafter called Contract, which Contract is incorporated herein by reference and made a part hereof.

**NOW, THEREFORE**, the condition of this obligation is such that:

If the Principal shall promptly and faithfully perform, and fully complete the Contract in strict accordance with the terms of the Contract as said Contract may be modified or amended from time-to-time; then this obligation shall be void; otherwise to remain in full force and effect.

Surety to this Bond hereby binds and agrees that no changes, extensions of time, alterations, or additions to the terms of the Contract, including the work to be performed thereunder, and the specifications or drawings accompanying same, shall in any way affect its obligation on this bond, and it does hereby waive notice of any such changes, extensions of time, alterations, or additions, and agrees that they shall become part of the Contract.

In the event of Default by the Principal, of the obligations under the Contract, then after written Notice of Default from the Obligee to the Surety and the Principal and subject to the limitation of the penal sum of this bond, Surety shall remedy the Default, or take over the work to be performed under the Contract and complete such work, or pay moneys to the Obligee in satisfaction of the surety performance obligation on this bond.

Signed this \_\_\_\_\_ day of \_\_\_\_\_, 20\_\_\_\_.

(Seal)

\_\_\_\_\_  
Name of Principal (Contractor)

\*  
\_\_\_\_\_  
Signature

\_\_\_\_\_  
Title  
(Seal)

\_\_\_\_\_  
Name of Surety

\*  
\_\_\_\_\_  
Signature

\_\_\_\_\_  
Title

\*ALL SIGNATURES MUST BE ACKNOWLEDGED  
BY A NOTARY PUBLIC

PERFORMANCE BOND (SURETY) (EXHIBIT B)

# EXHIBIT C - PERFORMANCE BOND

## PERFORMANCE BOND (11/15/11)

### KNOW TO ALL BY THESE PRESENTS:

That we,

\_\_\_\_\_  
(full legal name and street address of Contractor)  
as Contractor, hereinafter called Contractor, is held and firmly bound unto the Department of Water, City of Kaua'i, its successors and assigns, as Obligee, hereinafter called Obligee, in the amount of

\_\_\_\_\_  
(dollar amount of contract)  
DOLLARS (\$ \_\_\_\_\_), lawful money of the United States of America, for the payment of which to the said Obligee, well and truly to be made, Contractor binds itself, its heirs, executors, administrators, successors and assigns, firmly by these presents. Said amount is evidenced by:

- Legal tender;
- Share Certificate unconditionally assigned to or made payable at sight to \_\_\_\_\_  
Description \_\_\_\_\_
- Certificate of Deposit, No. \_\_\_\_\_, dated \_\_\_\_\_, issued by \_\_\_\_\_, drawn on \_\_\_\_\_, a bank, savings institution or credit union insured by the Federal Deposit Insurance Corporation or the National Credit Union Administration, payable at sight or unconditionally assigned to \_\_\_\_\_;
- Cashier's Check No. \_\_\_\_\_, dated \_\_\_\_\_, issued by \_\_\_\_\_, drawn on \_\_\_\_\_, a bank, savings institution or credit union insured by the Federal Deposit Insurance Corporation or the National Credit Union Administration, payable at sight or unconditionally assigned to \_\_\_\_\_;
- Treasurer's Check No. \_\_\_\_\_, dated \_\_\_\_\_, issued by \_\_\_\_\_, drawn on \_\_\_\_\_, a bank, savings institution or credit union insured by the Federal Deposit Insurance Corporation or the National Credit Union Administration, payable at sight or unconditionally assigned to \_\_\_\_\_;
- Official Check No. \_\_\_\_\_, dated \_\_\_\_\_, issued by \_\_\_\_\_, drawn on a bank, savings institution or credit union insured by the Federal Deposit Insurance Corporation or the National Credit Union Administration, payable at sight or unconditionally assigned to \_\_\_\_\_;

PERFORMANCE BOND (EXHIBIT C)

- Certified Check No. \_\_\_\_\_, dated \_\_\_\_\_, accepted by a bank, savings institution or credit union insured by the Federal Deposit Insurance Corporation or the National Credit Union Administration, payable at sight or unconditionally assigned \_\_\_\_\_;

**WHEREAS:**

The Contractor has by written agreement dated \_\_\_\_\_ entered into a Contract with Oblige for the following Project:

\_\_\_\_\_  
\_\_\_\_\_

hereinafter called Contract, which Contract is incorporated herein by reference and made a part hereof.

**NOW, THEREFORE,**

The condition of this obligation is such that, if Contractor shall promptly and faithfully perform the Contract in accordance with, in all respects, the stipulations, agreements, covenants and conditions of the Contract as it now exists or may be modified according to its terms, and shall deliver the Project to the Oblige, or to its successors or assigns, fully completed as in the Contract specified and free from all liens and claims and without further cost, expense or charge to the Oblige, its officers, agents, successors or assigns, free and harmless from all suits or actions of every nature and kind which may be brought for or on account of any injury or damage, direct or indirect, arising or growing out of the doing of said work or the repair or maintenance thereof or the manner of doing of the same or the neglect of the Contractor or its agents or servants or the improper performance of the Contract by the Contractor or its agents or servants or from any other cause, then this obligation shall be void; otherwise it shall be and remain in full force and effect.

**AND IT IS HEREBY STIPULATED AND AGREED** that suit on this bond may be brought before a court of competent jurisdiction without a jury, and that the sum or sums specified in the said Contract as liquidated damages, if any, shall be forfeited to the Oblige, its successors or assigns, in the event of a breach of any, or all, or any part of, the covenants, agreements, conditions, or stipulations contained in the Contract or in this bond or in accordance with the terms thereof.

The amount of this bond may be reduced by and to the extent of any payment or payments made in good faith hereunder.

Signed this \_\_\_\_\_ day of \_\_\_\_\_, 20\_\_\_\_.

(Seal)

\_\_\_\_\_  
Name of Contractor

\*  
\_\_\_\_\_  
Signature

\_\_\_\_\_  
Title

\*ALL SIGNATURES MUST BE ACKNOWLEDGED  
BY A NOTARY PUBLIC

PERFORMANCE BOND (EXHIBIT C)

**EXHIBIT D – LABOR AND MATERIAL PAYMENT BOND (SURETY)**  
**LABOR AND MATERIAL PAYMENT BOND (SURETY)**

(11/15/11)

**KNOW TO ALL BY THESE PRESENTS:**

That \_\_\_\_\_,  
(full legal name and street address of Contractor)  
as Contractor, hereinafter called Principal, and

\_\_\_\_\_  
(name and street address of bonding company)  
as Surety, hereinafter called Surety, a corporation(s) authorized to transact business as a Surety in the State of Hawai'i, are held and firmly bound unto the Department of Water, County of Kaua'i, its successors and assigns, hereinafter called Oblige, in the amount of \_\_\_\_\_ Dollars (\$ \_\_\_\_\_), to which payment Principal and Surety bind themselves, their heirs, executors, administrators, successors and assigns, jointly and severally, firmly by these presents.

**WHEREAS**, the above-bound Principal has signed a Contract as Oblige on \_\_\_\_\_  
for the following  
project: \_\_\_\_\_,  
hereinafter called Contract, which Contract is incorporated herein by reference and made a part hereof.

**NOW THEREFORE**, the condition of this obligation is such that if the Principal shall promptly make payment to any Claimant, as hereinafter defined, for all labor and material supplied to the Principal for use in the performance of the Contract, then this obligation shall be void; otherwise to remain in full force and effect.

1. Surety to this Bond hereby stipulates and agrees that no changes, extensions of time, alterations, or additions to the terms of the Contract, including the work to be performed hereunder, and the specifications or drawings accompanying same, shall in any way affect its obligation on this bond, and it does hereby waive notice of any such changes, extensions of time, alterations, or additions, and agrees that they shall become part of the Contract.

2. A "Claimant" shall be defined here as any person who has furnished labor or materials to the Principal for the work provided in the Contract.

Every Claimant who has not been paid amounts due for labor and materials furnished for work provided in the Contract may institute an action against the Principal and the Surety on this bond at the time and in the manner prescribed in Section 103D-24, Hawai'i Revised Statutes, and have the rights and claims adjudicated in the action, and judgment rendered thereon, subject to the Oblige's priority on this bond. If the full amount of the liability of the Surety on this bond is insufficient to pay the full amount of the claims, then after paying the full amount due the Oblige, the remainder shall be distributed pro rata among the claimants.

Signature of Principal dated this \_\_\_\_\_ day of \_\_\_\_\_, 20\_\_\_\_.  
(Seal)

\_\_\_\_\_  
Name of Principal (Contractor)

\* \_\_\_\_\_  
Signature

\_\_\_\_\_  
Title

(Seal)

\_\_\_\_\_  
Name of Surety

\* \_\_\_\_\_  
Signature

\_\_\_\_\_  
Title

\*ALL SIGNATURES MUST BE ACKNOWLEDGED  
BY A NOTARY PUBLIC  
LABOR AND MATERIAL PAYMENT BOND (SURETY) (EXHIBIT D)

# EXHIBIT E - LABOR AND MATERIAL PAYMENT BOND

## LABOR AND MATERIAL PAYMENT BOND (11/15/11)

### KNOW TO ALL BY THESE PRESENTS:

That we,

\_\_\_\_\_  
(full legal name and street address of Contractor)

as Contractor, hereinafter called Contractor, is held and firmly bound unto the Department of Water, County of Kauai, its successors and assigns, as Obligee, hereinafter called Obligee, in the amount of

\_\_\_\_\_  
(dollar amount of contract)

DOLLARS (\$ \_\_\_\_\_), lawful money of the United States of America, for the payment of which to the said Obligee, well and truly to be made, Contractor binds itself, its heirs, executors, administrators, successors and assigns, firmly by these presents. Said amount is evidenced by:

- Legal tender;
- Share Certificate unconditionally assigned, made payable at sight:  
\_\_\_\_\_  
Description \_\_\_\_\_
- Certificate of Deposit, No. \_\_\_\_\_, dated \_\_\_\_\_, issued by \_\_\_\_\_, drawn on \_\_\_\_\_, a bank, savings institution or credit union insured by the Federal Deposit Insurance Corporation or the National Credit Union Administration, payable at sight or unconditionally assigned to \_\_\_\_\_;
- Cashier's Check No. \_\_\_\_\_, dated \_\_\_\_\_, issued by \_\_\_\_\_, drawn on \_\_\_\_\_, a bank, savings institution or credit union insured by the Federal Deposit Insurance Corporation or the National Credit Union Administration, payable at sight or unconditionally assigned to \_\_\_\_\_;
- Teller's Check No. \_\_\_\_\_, dated \_\_\_\_\_, issued by \_\_\_\_\_, drawn on \_\_\_\_\_, a bank, savings institution or credit union insured by the Federal Deposit Insurance Corporation or the National Credit Union Administration, payable at sight or unconditionally assigned to \_\_\_\_\_;
- Treasurer's Check No. \_\_\_\_\_, dated \_\_\_\_\_, issued by \_\_\_\_\_, drawn on \_\_\_\_\_, a bank, savings institution or credit union insured by the Federal Deposit Insurance Corporation or the National Credit Union Administration, payable at sight or unconditionally assigned to \_\_\_\_\_;

LABOR AND MATERIAL PAYMENT BOND  
(EXHIBIT E)

- Official Check No. \_\_\_\_\_, dated \_\_\_\_\_, issued by \_\_\_\_\_, drawn on a bank, savings institution or credit union insured by the Federal Deposit Insurance Corporation or the National Credit Union Administration, payable at sight or unconditionally assigned to \_\_\_\_\_;
- Certified Check No. \_\_\_\_\_, dated \_\_\_\_\_, accepted by a bank, savings institution or credit union insured by the Federal Deposit Insurance Corporation or the National Credit Union Administration, payable at sight or unconditionally assigned \_\_\_\_\_;

**WHEREAS:**

The Contractor has by written agreement dated \_\_\_\_\_ entered into a Contract with Obligeo for the following Project:

\_\_\_\_\_  
 \_\_\_\_\_  
 \_\_\_\_\_

hereinafter called Contract, which Contract is incorporated herein by reference and made a part hereof.

**NOW, THEREFORE,**

The condition of this obligation is such that, if Contractor shall promptly and faithfully perform the Contract in accordance with, in all respects, the stipulations, agreements, covenants and conditions of the Contract as it now exists or may be modified according to its terms, free from all liens and claims and without further cost, expense or charge to the Obligeo, its officers, agents, successors, or assigns, free and harmless from all suits or actions of every nature and kind which may be brought for or on account of any injury or damage, direct or indirect, arising or growing out of the doing of said work or the repair or maintenance thereof or the manner of doing the same or the neglect of the Contractor or its agents or servants or the improper performance of the Contract by the Contractor or its agents or servants or from any other cause, and shall promptly pay all persons supplying labor and materials for the performance of the Contract, then this obligation shall be void; otherwise it shall be and remain in full force and effect.

**AND IT IS HEREBY STIPULATED AND AGREED** that suit on this bond may be brought before a court of competent jurisdiction without a jury, and that the sum or sums specified in the said Contract as liquidated damages, is any, shall be forfeited to the Obligeo, its successor or assigns, in the event of a breach of any, or all, or any part of, the covenants, agreements, conditions, or stipulations contained in the Contract or in this bond in accordance with the terms thereof.

**AND IT IS HEREBY STIPULATED AND AGREED** that this bond shall inure to the benefit of any and all persons entitled to file claims for labor performed or materials furnished in said work so as to give any and all such persons a right of action as contemplated by Sections 103D-324(d) and 103D-324(e), Hawai'i Revised Statutes.

The amount of this bond shall be reduced by and to the extent of any payment or payments made in good faith hereunder, inclusive of the payment of mechanics' liens which may be filed of record against the Project, whether or not claim for the amount of such lien be presented under and against this bond.

Signed this \_\_\_\_\_ day of \_\_\_\_\_, 20\_\_\_\_.

(Seal)

\_\_\_\_\_  
 Name of Contractor

\*  
 \_\_\_\_\_  
 Signature

\_\_\_\_\_  
 Title

\*ALL SIGNATURES MUST BE  
 ACKNOWLEDGED BY A NOTARY  
 PUBLIC

LABOR AND MATERIAL PAYMENT BOND (EXHIBIT E)



**EXHIBIT F – PERFORMANCE BOND (SURETY) FOR SUPPLEMENTAL AGREEMENT FOR GOODS AND SERVICES**

(11/15/11)

**KNOW TO ALL BY THESE PRESENTS:**

That

\_\_\_\_\_  
(full legal name and street address of Contractor)  
as Contractor, hereinafter called Principal, and

\_\_\_\_\_  
(name and street address of bonding company)  
as Surety, hereinafter called Surety, a corporation(s) authorized to transact business as a Surety in the State of Hawai'i, are held and firmly bound unto the Department of Water, County of Maui, its successors and assigns, hereinafter called Oblige, in the amount of \_\_\_\_\_ Dollars (\$ \_\_\_\_\_), to which payment Principal and Surety bind themselves, their heirs, executors, administrators, successors and assigns, jointly and severally, firmly by these presents.

**WHEREAS**, the above-bound Principal has entered into Contract with Oblige, dated \_\_\_\_\_, for \_\_\_\_\_, and entered into Supplemental Agreement No. \_\_\_\_\_, dated \_\_\_\_\_, for the period hereinafter collectively called Contract, with Contract is incorporated here by reference and made a part hereof.

**NOW THEREFORE**, the condition of the obligation is such that:

If the Principal shall promptly and faithfully perform, and fully complete the Contract in strict accordance with the terms of the Contract as said Contract may be modified or amended from time to time; then this obligation shall be void; otherwise to remain in full force and effect.

Surety to this Bond here stipulates and agrees that no changes, extensions of time, alterations, or additions to the terms of the Contract, including the work to be performed thereunder, and the specifications or drawings accompanying same, shall in any way affect its obligation on this bond, and it does hereby waive notice of any such changes, extensions of time, alterations or additions, and agrees that they shall become part of the Contract.

In the event of Default by the Principal, of the obligations under the Contract, then after written Notice of Default from the Oblige, the Surety and the Principal, Surety shall either remedy the Default, or take over the work to be performed under the Contract and complete such work, subject, however, to the limitation of the penal sum of this bond.

Signed \_\_\_\_\_ day of \_\_\_\_\_, 20\_\_\_\_.

(Seal)

\_\_\_\_\_  
Name of Principal (Contractor)

\*

\_\_\_\_\_  
Signature

\_\_\_\_\_  
Title

(Seal)

\_\_\_\_\_  
Name of Surety

\*

\_\_\_\_\_  
Signature

\_\_\_\_\_  
Title

\*ALL SIGNATURES MUST BE  
ACKNOWLEDGED BY A NOTARY PUBLIC

PERFORMANCE BOND (SURETY) FOR SUPPLEMENTAL  
AGREEMENT FOR GOODS AND SERVICES (EXHIBIT F)

**EXHIBIT G- PERFORMANCE BOND FOR SUPPLEMENTAL AGREEMENT  
FOR GOODS AND SERVICES**

(11/15/11)

**KNOW TO ALL BY THESE PRESENTS:**

That we, \_\_\_\_\_,

(full legal name and street address of Contractor)

as Contractor, hereinafter called Contractor, is held and firmly bound unto the Department of Water, County of Kaua'i, its successors and assigns, as Obligee, hereinafter called Obligee, in the amount of

\_\_\_\_\_ (dollar amount of contract)

DOLLARS (\$ \_\_\_\_\_), lawful money of the United States of America for the payment of which the said Obligee, well and truly to be made, Contractor binds itself, its heirs, executors, administrators, successors and assigns, firmly by these presents. Said amount is evidenced by:

- Legal tender;
- Share Certificate unconditionally assigned to or payable at sight to \_\_\_\_\_  
Description \_\_\_\_\_
- Certificate of Deposit, No. \_\_\_\_\_, dated \_\_\_\_\_, issued by \_\_\_\_\_ drawn on \_\_\_\_\_ a bank, savings institution or credit union insured by the Federal Deposit Insurance Corporation or the National Credit Union Administration, payable at sight or unconditionally assigned to \_\_\_\_\_;
- Cashier's Check No. \_\_\_\_\_, dated \_\_\_\_\_, issued by \_\_\_\_\_ drawn on \_\_\_\_\_ a bank, savings institution or credit union insured by the Federal Deposit Insurance Corporation or the National Credit Union Administration, payable at sight or unconditionally assigned to \_\_\_\_\_;
- Teller's Check No. \_\_\_\_\_, dated \_\_\_\_\_, issued by \_\_\_\_\_ drawn on \_\_\_\_\_ a bank, savings institution or credit union insured by the Federal Deposit Insurance Corporation or the National Credit Union Administration, payable at sight or unconditionally assigned to \_\_\_\_\_;
- Treasurer's Check No. \_\_\_\_\_, dated \_\_\_\_\_, issued by \_\_\_\_\_ drawn on \_\_\_\_\_ a bank, savings institution or credit union insured by the Federal Deposit Insurance Corporation or the National Credit Union Administration, payable at sight or unconditionally assigned to \_\_\_\_\_;
- Official Check No. \_\_\_\_\_, dated \_\_\_\_\_, issued by \_\_\_\_\_ drawn on a bank, savings institution or credit union insured by the Federal Deposit Insurance Corporation or the National Credit Union Administration, payable at sight or unconditionally assigned to \_\_\_\_\_;

**Not Applicable, Refer to Exhibit J**

PERFORMANCE BOND  
FOR SUPPLEMENTAL AGREEMENT FOR GOODS AND SERVICES (EXHIBIT G)

Certified Check No. \_\_\_\_\_, dated \_\_\_\_\_, accepted by a bank, savings institution or credit union insured by the Federal Deposit Insurance Corporation or the National Credit Union Administration, payable at sight or unconditionally assigned \_\_\_\_\_;

**WHEREAS:**

The Contractor has by written agreement dated \_\_\_\_\_ entered into a Contract with Obligeo for the following Project:

\_\_\_\_\_  
\_\_\_\_\_  
\_\_\_\_\_ and entered into Supplemental Agreement No. \_\_\_\_\_, dated \_\_\_\_\_ for the period \_\_\_\_\_; hereinafter collectively called Contract, which Contract is incorporated herein by reference and made a part hereof.

**NOW, THEREFORE,**

The condition of this obligation is such that, if Contractor shall promptly and faithfully perform the Contract in accordance with, in all respects, the stipulations, agreements, covenants and conditions of the Contract as it now exists or may be modified according to its terms, and shall deliver the Project to the Obligeo, or to its successors or assigns, fully completed as in the Contract specified and free from all liens and claims and without further cost, expense or charge to the Obligeo, its officers, agents, successors, or assigns, free and harmless from all suits or actions of every nature and kind which may be brought for or on account of any injury or damage, direct or indirect, arising or growing out of the doing of said work or the repair or maintenance thereof or the manner of doing the same or the neglect of the Contractor or its agents or servants or the improper performance of the Contract by the Contractor or its agents or servants or from any other cause, then this obligation shall be void; otherwise it shall be and remain in full force and effect.

**AND IT IS HEREBY STIPULATED AND AGREED** that suit on this bond may be brought before a court of competent jurisdiction without a jury, and that the sum or sums specified in the said Contract as liquidated damages, is any, shall be forfeited to the Obligeo, its successor or assigns, in the event of a breach of any, or all, or any part of, the covenants, agreements, conditions, or stipulations contained in the Contract or in this bond in accordance with the terms thereof.

The amount of this bond may be reduced by and to the extent of any payment or payments made in good faith hereunder.

Signed and sealed this \_\_\_\_\_ day of \_\_\_\_\_, 20\_\_\_\_.

(Seal)

\_\_\_\_\_  
Name of Contractor

\*  
\_\_\_\_\_  
Signature

\_\_\_\_\_  
Title

\*ALL SIGNATURES MUST BE ACKNOWLEDGED BY A NOTARY PUBLIC

PERFORMANCE BOND FOR SUPPLEMENTAL AGREEMENT FOR GOODS AND SERVICES (EXHIBIT G)

# EXHIBIT H - CONTRACTOR ACKNOWLEDGMENT

[FOR USE WITH PERFORMANCE AND PAYMENT BONDS]  
(11/15/11)

## CONTRACTOR ACKNOWLEDGMENT:

STATE OF \_\_\_\_\_ )  
 ) : SS  
\_\_\_\_\_ COUNTY OF \_\_\_\_\_ )

On this \_\_\_\_\_ day of \_\_\_\_\_, 20\_\_\_\_, before me appeared \_\_\_\_\_  
and \_\_\_\_\_ to me known to be the person(s) described in and, who, being duly sworn,  
did say that he/she/they is/are \_\_\_\_\_ and \_\_\_\_\_  
of \_\_\_\_\_ the Contractor named in the foregoing instrument, and that he/she/they  
is/are authorized to sign said instrument in behalf of the Contractor, and acknowledges that he/she/they executed said  
instrument as the free act and deed of the Contractor.

\_\_\_\_\_  
(Notary Seal)  
Notary Public  
State of \_\_\_\_\_  
My commission expires \_\_\_\_\_

CONTRACTOR ACKNOWLEDGMENT (EXHIBIT H)

**EXHIBIT I - SURETY ACKNOWLEDGMENT**

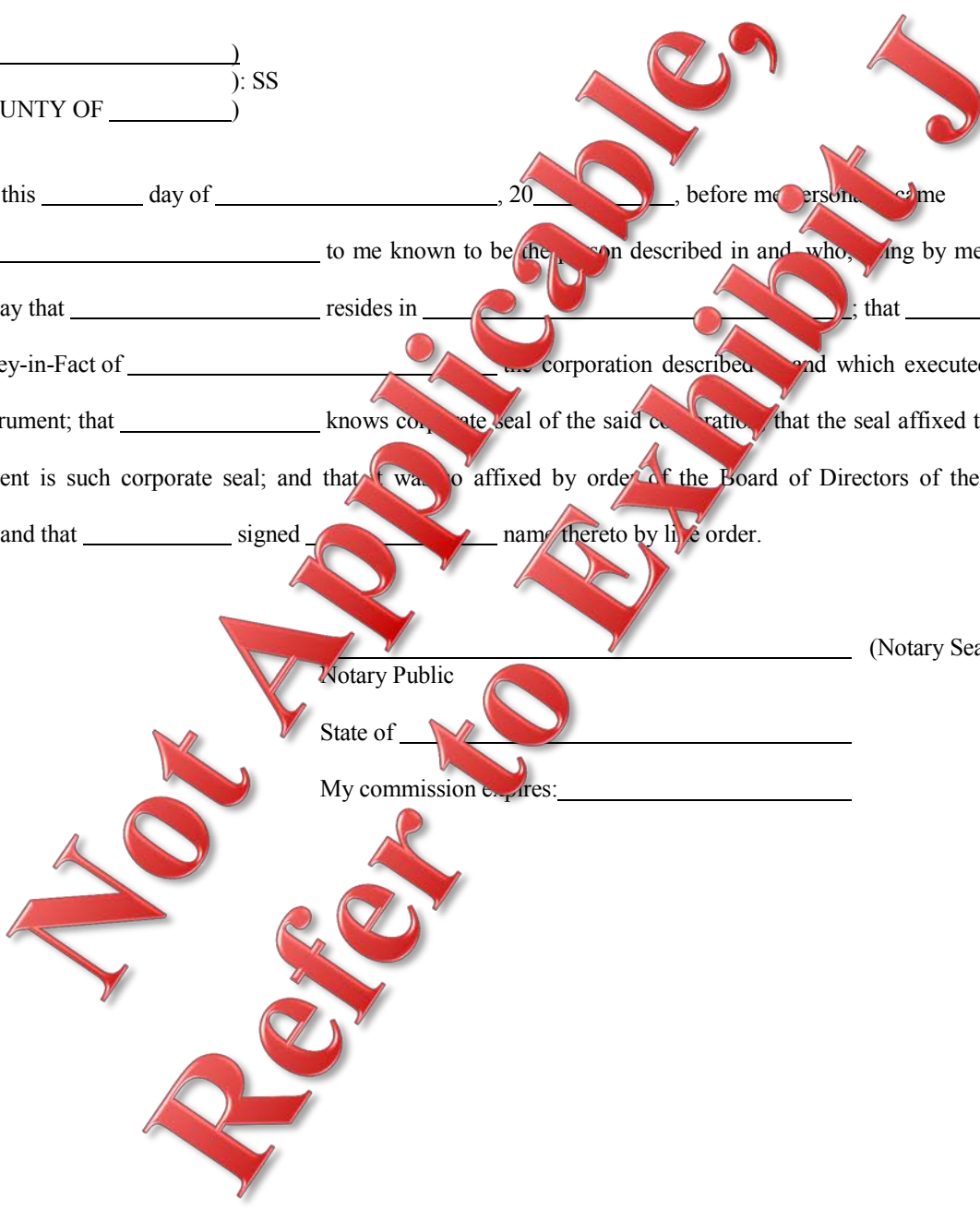
[FOR USE WITH SURETY PERFORMANCE AND PAYMENT BONDS]  
(11/15/11)

SURETY ACKNOWLEDGMENT:

STATE OF \_\_\_\_\_ )  
 ) : SS  
\_\_\_\_\_ COUNTY OF \_\_\_\_\_ )

On this \_\_\_\_\_ day of \_\_\_\_\_, 20\_\_\_\_, before me personally came \_\_\_\_\_ to me known to be the person described in and who, acting by me, did depose and say that \_\_\_\_\_ resides in \_\_\_\_\_; that \_\_\_\_\_ is the Attorney-in-Fact of \_\_\_\_\_ the corporation described \_\_\_\_\_ and which executed the attached instrument; that \_\_\_\_\_ knows corporate seal of the said corporation, that the seal affixed to the said instrument is such corporate seal; and that it was so affixed by order of the Board of Directors of the said corporation; and that \_\_\_\_\_ signed \_\_\_\_\_ name thereto by live order.

\_\_\_\_\_  
Notary Public (Notary Seal)  
State of \_\_\_\_\_  
My commission expires: \_\_\_\_\_



# EXHIBIT J – SAMPLE CONTRACT

SAMPLE CONTRACT  
(05/19/16)



CONTRACT NO. \_\_\_\_\_

## CONSTRUCTION CONTRACT

THIS CONTRACT, effective as of the date of the last signatory, is made and entered into by and between the **Board of Water Supply, County of Kaua'i**, whose mailing address is 4398 Pua Loke Street, Lihu'e, Hawai'i 96766 (hereinafter the "BOARD") and \_\_\_\_\_, a \_\_\_\_\_, under the laws of the State of \_\_\_\_\_, whose principle mailing address is \_\_\_\_\_ (hereinafter the "CONTRACTOR");

THIS CONTRACT for construction services has been procured under:

- Hawai'i Revised Statute (H.R.S.) §103D-302 (Competitive Sealed Bidding)
- H.R.S. §103D-303 (Competitive Sealed Proposals)
- H.R.S. §103D-305 (Small Purchase)
- H.R.S. §103D-307 (Emergency Procurement # \_\_\_\_\_)

### WITNESSETH:

THAT, for and in consideration of the payment(s) hereinafter set forth to be made by the Board, the Contractor agrees to furnish and pay for all materials, supplies, tools, equipment, labor, utilities, transportation, services, and any and all other incidentals necessary to construct in place and complete, free of all liens, claims, and any encumbrances whatsoever:



(hereinafter "PROJECT").

1. Contract Documents: The Contractor agrees to complete the PROJECT in accordance with this Contract and the following documents:

- Approved construction drawings;
- Specifications;
- Invitation for Bids Document No. \_\_\_\_\_ and all Addenda thereto;
- Request for Proposals PROJECT No. \_\_\_\_\_ and all Addenda thereto;

- Bid/Proposal/Best and Final Offer;
- Method of Award;
- Wage Rate Schedule;
- Construction Schedules;
- Special Provisions;
- General Provisions for Construction Contracts of the Department of Water Dated April 25, 2016;

and those other documents attached or referred to therein, relating to the PROJECT (hereinafter collectively referred to as "Contract Documents"). The Contractor understands and agrees that the Contract Documents including, but not limited to, those referenced in but not attached to this Contract and those referenced in but not attached to the Contract Documents, are hereby incorporated by reference into this Contract. The Contractor acknowledges and admits receipt of all Contract Documents, and acknowledges that it has reviewed, understands, and agrees with all terms and conditions in the Contract Documents and those other documents, terms and conditions referenced therein.

2. **Time of Performance:** The Contractor agrees to complete the PROJECT within \_\_\_\_\_ CALENDAR DAYS, from and including the date as specified in the written Notice to Proceed.
3. **Compensation:** For and in consideration of the Contractor's full and faithful performance of this entire Contract, the Board hereby agrees to pay the Contractor the sum of

\_\_\_\_\_

**DOLLARS (\$\_\_\_\_\_)**, federal, state and local taxes included, in lawful money of the United States of America; provided that the Contractor understands and agrees that payment shall be made in the manner and at the times specified in the Contract Documents, and shall also be subject to and conditioned upon such additions to or deductions from the preceding sum as may herein be made, according to the Contract Documents.

4. **Liquidated Damages:** THE CONTRACTOR UNDERSTANDS AND AGREES that time is an essential factor of this Contract; that the Board will suffer material loss by reason of delays that may occur in the Contractor's performance of the work or any portions of the work within the time or times fixed in the Contract or any extensions thereto; and that as liquidated damages for any such delays, the sum of

\_\_\_\_\_

**DOLLARS (\$\_\_\_\_\_)**, for each and every calendar day which said performance remains uncompleted will be charged the Contractor and deducted from the Contract price; and it is expressly stipulated by and between the Contractor and Board that any such sums shall be deemed and taken to be liquidated damages for the Contractor's failure to perform within the specified time and not be in the nature of penalty.

5. **Bonds:** The Contractor is required to provide the following bonds, in an amount equal to 100% of the amount of the Contract price in the form(s) set forth in **Exhibit A**:

- Performance Bond (**Exhibit A1**)
- Labor and Material Payment Bond (**Exhibit A2**)
- Not Applicable

6. **Insurance:** Contractor shall procure and maintain, on primary basis and at its sole expense, at all times during the life of the Contract insurance coverages, limit, including endorsements as described in **Exhibit B**, incorporated herein, against claims for injuries to person or damages to property which may arise from or in connection with the performance of the work by the Contractor or the Contractor's agents, representatives, employees or subcontractors. The requirements contained herein, as well as the Board's review or acceptance of insurance maintained by the contractor is not intended to and shall not in any manner limit or qualify the liabilities or obligations assumed by the Contractor.

7. **Officer in Charge:** The Officer in Charge of this PROJECT is:

\_\_\_\_\_  
\_\_\_\_\_

8. **Severability:** In the event any term or provision of this Contract is declared to be invalid or illegal for any reason, this Contract will remain in full force and effect and will be interpreted as though such invalid or illegal provision were not a part of this Contract.

9. **Execution in Counterparts:** This Contract may be executed in counterparts, all of which shall be considered the same as if a single document shall have been executed, but shall become effective when such counterparts have been signed by each of the parties hereto and delivered to each party. Further, facsimile signatures and notarizations are permissible provided original signatures and notarizations bearing the notary's seal are later provided to the party in receipt of the facsimile signature and notarizations.

10. **Waiver:** Waiver of a breach or default under this Agreement shall not constitute a continuing waiver or a waiver of a subsequent breach of the same or any other provision of this Agreement.

THE PARTIES FURTHER AGREE that:

- Concurrently with its execution of this Contract, Contractor shall submit to the Officer-in-Charge:
  - a tax clearance pursuant to Haw. Rev. Stat., as amended (hereinafter "H.R.S." §103-53;
  - a Certificate of Compliance pursuant to Hawai'i Administrative Rules (hereinafter "H.A.R.") §3-122-112; and



- a Certificate of Good Standing pursuant to H.A.R. §3-122-112.

Further, as a condition of final payment on this Contract, Contactor shall submit to the Officer-in-Charge:

- a tax clearance to pursuant to H.R.S. §103-53; and
- a Certificate of Compliance pursuant to H.A.R. §3-122-112.

All clearances and certificates submitted pursuant to the foregoing statutory requirements shall be valid when the Contract is executed by all parties hereto and when final payment is made.

As used in this Contract, “Board” means the Board of Water Supply of the County of Kaua‘i and the Department of Water, County of Kaua‘i, and its officers, agents, and employees.

IN WITNESS WHEREOF, the parties hereto have hereunto caused this instrument to be executed as of the \_\_\_\_\_ day of \_\_\_\_\_, \_\_\_\_\_.

APPROVED:

\_\_\_\_\_

BOARD OF WATER SUPPLY  
COUNTY OF KAUA‘I

By \_\_\_\_\_

APPROVED AS TO FORM  
AND LEGALITY:

\_\_\_\_\_

CONTRACTOR

By \_\_\_\_\_  
Its \_\_\_\_\_

By \_\_\_\_\_  
Its \_\_\_\_\_



STATE OF HAWAI'I )  
 ) ss.  
COUNTY OF \_\_\_\_\_)

On this \_\_\_\_\_ day of \_\_\_\_\_, \_\_\_\_\_, before me appeared  
\_\_\_\_\_ to me personally known, who being by me was duly sworn, did say he/she is the \_\_\_  
\_\_\_\_\_ of \_\_\_\_\_, a \_\_\_\_\_ and that said instrument  
was signed and sealed on behalf of said \_\_\_\_\_; and said officer acknowledged said instrument to be  
the free act and deed of said \_\_\_\_\_.

\_\_\_\_\_  
Notary Public, State of Hawai'i

Name of Notary: \_\_\_\_\_

My commission expires: \_\_\_\_\_

***(PLEASE INSERT YOUR APPLICABLE NOTARY SECTION)***

**EXHIBIT A1**  
**PERFORMANCE BOND (SURETY)**

KNOW ALL MEN BY THESE PRESENTS:

That \_\_\_\_\_,

a \_\_\_\_\_ corporation, whose principle mailing address is

\_\_\_\_\_

as Principal, (hereinafter referred to as "Principal"), and \_\_\_\_\_,

as Surety, (hereinafter referred to as "Surety"), a corporation(s) authorized to transact business as a surety in the State of Hawai'i, are held and firmly bound unto the Board of Water Supply, its successors and assigns, (hereinafter referred to as "Obligee"), in the amount of

\_\_\_\_\_

**DOLLARS (\$\_\_\_\_\_)** to which payment Principal and Surety bind themselves, their heirs, executors, administrators, successors and assigns, jointly and severally, firmly by these presents.

**WHEREAS**, the above-bound Principal has entered into a Contract with Obligee dated \_\_\_\_\_ for \_\_\_\_\_ (hereinafter referred to as the "Contract"), which Contract is incorporated herein by reference and made a part hereof.

**NOW THEREFORE**, the condition of this obligation is such that:

If the Principal shall promptly and faithfully perform, and fully complete the Contract in strict accordance with the terms of the Contract as said Contract may be modified or amended from time to time; then this obligation shall be void; otherwise to remain in full force and effect.

Surety to this bond hereby stipulated and agrees that no changes, extensions of time, alterations, or additions to the terms of the Contract, including the work to be performed thereunder, and the specifications or drawings accompanying same, shall in any way affect its obligation on this bond, and it does hereby waive notice of any such changes, extensions of time, alterations, or additions, and agrees that they shall become part of the Contract.

In the event of Default by the Principal, of the obligations under the Contract, then after written Notice of Default from the Obligee to the Surety and the Principal, Surety shall either remedy the Default, or take over the work to be performed under the contract and complete such work, subject, however, to the limitation of the penal sum of this bond.

Signed and sealed this \_\_\_\_\_ day of \_\_\_\_\_, \_\_\_\_\_.

\_\_\_\_\_  
Principal Seal

By \_\_\_\_\_

Its By \_\_\_\_\_

Its \_\_\_\_\_

\_\_\_\_\_  
Surety Seal

By \_\_\_\_\_

Its By \_\_\_\_\_

Its \_\_\_\_\_

**ALL SIGNATURES MUST BE ACKNOWLEDGED BY A NOTARY PUBLIC**

SURETY PERFORMANCE BOND

STATE OF HAWAI'I )  
 ) ss.  
COUNTY OF \_\_\_\_\_ )

On this \_\_\_\_\_ day of \_\_\_\_\_, \_\_\_\_\_, before me appeared \_\_\_\_\_ to me personally known, who being by me was duly sworn, did say he/she is the \_\_\_\_\_ of \_\_\_\_\_, a \_\_\_\_\_; that the seal affixed to the foregoing instrument is the \_\_\_\_\_ seal of said \_\_\_\_\_; and said officer acknowledged said instrument to be the free act and deed of said \_\_\_\_\_.

\_\_\_\_\_  
Notary Public, State of Hawai'i

Name of Notary: \_\_\_\_\_

My commission expires: \_\_\_\_\_

**(SURETY PLEASE INSERT YOUR APPLICABLE NOTARY SECTION.)**

**EXHIBIT A1  
PERFORMANCE BOND**

**KNOW TO ALL BY THESE PRESENTS:**

That we, \_\_\_\_\_, as Contractor, hereinafter called Contractor, is held and firmly bound unto the \_\_\_\_\_, its successors and assigns, as Obligee, hereinafter called Obligee, in the amount of

\_\_\_\_\_ **DOLLARS (\$\_\_\_\_\_)**, lawful money of the United States of America, for the payment of which to the said Obligee, well and truly to be made, Contractor binds itself, its heirs, executors, administrators, successors and assigns, firmly by these presents. Said amount is evidenced by:

- Legal tender;
- Share Certificate unconditionally assigned to or made payable at sight to  
\_\_\_\_\_  
Description \_\_\_\_\_;
- Certificate of Deposit, No. \_\_\_\_\_, dated \_\_\_\_\_,  
issued by \_\_\_\_\_,  
drawn on \_\_\_\_\_,  
a bank, savings institution or credit union insured by the Federal Deposit Insurance Corporation or the Nation Credit Union Administration, payable at sight or unconditionally assigned to \_\_\_\_\_;
- Cashier's Check No. \_\_\_\_\_, dated \_\_\_\_\_,  
issued by \_\_\_\_\_,  
drawn on \_\_\_\_\_,  
a bank, savings institution or credit union insured by the Federal Deposit Insurance Corporation or the National Credit Union Administration, payable at sight or unconditionally assigned to \_\_\_\_\_;
- Teller's Check No. \_\_\_\_\_, dated \_\_\_\_\_,  
issued by \_\_\_\_\_,  
drawn on \_\_\_\_\_;

a bank, savings institution or credit union insured by the Federal Deposit Insurance Corporation or the National Credit Union Administration, payable at sight or unconditionally assigned to

\_\_\_\_\_;

Treasurer's Check No. \_\_\_\_\_, dated \_\_\_\_\_,

issued by \_\_\_\_\_,

drawn on \_\_\_\_\_,

a bank, savings institution or credit union insured by the Federal Deposit Insurance Corporation or the National Credit Union Administration, payable at sight or unconditionally assigned to

\_\_\_\_\_;

Official Check No. \_\_\_\_\_, dated \_\_\_\_\_,

issued by \_\_\_\_\_,

drawn on \_\_\_\_\_,

a bank, savings institution or credit union insured by the Federal Deposit Insurance Corporation or the National Credit Union Administration, payable at sight or unconditionally assigned to

\_\_\_\_\_;

Certified Check No. \_\_\_\_\_, dated \_\_\_\_\_,

accepted by a bank, savings institution or credit union insured by the Federal Deposit Insurance Corporation or the National Credit Union Administration, payable at sight or unconditionally assigned \_\_\_\_\_;

WHEREAS:

The Contractor has by written agreement dated \_\_\_\_\_ entered into a contract with Oblige  
for the following PROJECT:

\_\_\_\_\_

hereinafter called Contract, which Contract is incorporated herein by reference and made a part hereof.

**NOW, THEREFORE,**

The condition of this obligation is such that, if Contractor shall promptly and faithfully perform the Contract in accordance with, in all respects, the stipulations, agreements, covenants and conditions of the Contract as it now exists or may be modified according to its terms, and shall deliver the PROJECT to the Oblige, or to its successors or assigns, fully completed as in the Contract specified and free from all liens and claims and without further cost, expense or charge to the Oblige, its officers, agents, successors or assigns, free and harmless from all suits or actions of every

nature and kind which may be brought for or on account of any injury or damage, direct or indirect, arising or growing out of the doing of said work or the repair or maintenance thereof or the manner of doing the same or the neglect of the Contractor or its agents or servants or the improper performance of the Contract by the Contractor or its agents or servants or from any other cause, then this obligation shall be void; otherwise it shall be and remain in full force and effect.

**AND IT IS HEREBY STIPULATED AND AGREED** that suit on this bond may be brought before a court of competent jurisdiction without a jury, and that the sum or sums specified in the said Contract as liquidated damages, if any, shall be forfeited to the Obligee, its successors or assigns, in the event of a breach of any, or all, or any part of, the covenants, agreements, conditions, or stipulations contained in the Contract or in this bond in accordance with the terms thereof.

The amount of this bond may be reduced by and to the extent of any payment or payments made in good faith hereunder.

Signed this \_\_\_\_\_ day of \_\_\_\_\_, \_\_\_\_\_.

(Seal) \_\_\_\_\_  
Name of Contractor  
\* \_\_\_\_\_  
Signature  
\_\_\_\_\_  
Title

STATE OF HAWAI'I )  
 ) ss.  
COUNTY OF \_\_\_\_\_)

On this \_\_\_\_\_ day of \_\_\_\_\_, \_\_\_\_\_, before me appeared \_\_\_\_\_ to me personally known, who being by me was duly sworn, did say he/she is the \_\_\_\_\_ of \_\_\_\_\_, a \_\_\_\_\_; that the seal affixed to the foregoing instrument is the \_\_\_\_\_ seal of said \_\_\_\_\_; and said officer acknowledged said instrument to be the free act and deed of said \_\_\_\_\_.

\_\_\_\_\_  
Notary Public, State of Hawai'i  
Name of Notary: \_\_\_\_\_  
My commission expires: \_\_\_\_\_

**ALL SIGNATURES MUST BE ACKNOWLEDGED BY A NOTARY PUBLIC.**



**EXHIBIT A2**  
**LABOR AND MATERIAL PAYMENT BOND (SURETY)**

**KNOW ALL MEN BY THESE PRESENTS:**

That \_\_\_\_\_, a \_\_\_\_\_  
corporation, whose principle mailing address is \_\_\_\_\_,  
as Principal (hereinafter referred to as "Principal"), and \_\_\_\_\_,  
as Surety (hereinafter referred to as "Surety"), a corporation(s) authorized to transact business as a surety in the State of  
Hawai'i, are held and firmly bound unto the Board of Water Supply, its successors and assigns (hereinafter referred to  
as "Obligee"), in the amount of

---

**DOLLARS (\$ \_\_\_\_\_)**, to which payment Principal and Surety bind themselves, their heirs, executors,  
administrators, successors and assigns, jointly and severally, firmly by these presents.

**WHEREAS**, the above-bound Principal has entered into a Contract with Obligee dated \_\_\_\_\_  
for \_\_\_\_\_ (hereinafter referred to as the "Contract"), which  
Contract is incorporated herein by reference and made a part hereof.

**NOW, THEREFORE**, the condition of this obligation is such that if the Principal shall promptly make  
payment to any Claimant, as hereinafter defined, for all labor and materials supplied to the Principal for use in the  
performance of the Contract, then this obligation shall be void; otherwise to remain in full force and effect.

1. Surety to this Bond hereby stipulates and agrees that no changes, extensions of time, alterations, or  
additions to the terms of the Contract, including the work to be performed thereunder, and the  
specifications or drawings accompanying same, shall in any way affect its obligation on this bond,  
and it does hereby waive notice of any such changes, extensions of time, alterations, or additions,  
and agrees that they shall become part of the Contract.
2. A "Claimant" shall be defined herein as any person who has furnished labor or materials to the  
Principal for the work provided in the Contract.

As provided in Section 103D-324, Hawai'i Revised Statutes, every Claimant who has not been paid in full  
before the expiration of a period of ninety days after the day on which the last of the labor was done or performed or  
material was furnished or supplied, for which such a claims made, may institute an action against the Principal or the  
Principal and its Surety, on this bond and have their rights and claims adjudicated in the action, and judgment rendered  
thereon; subject to the Obligee's priority on the bond. If the full amount of the liability of the Surety on the bond is

insufficient to pay the full amount of the claims, then after paying the full amount due the Obligee, the remainder shall be distributed pro rata among the claimants.

Signed and sealed this \_\_\_\_\_ day of \_\_\_\_\_, \_\_\_\_\_.

\_\_\_\_\_  
Principal Seal

By \_\_\_\_\_

Its By \_\_\_\_\_

Its \_\_\_\_\_

\_\_\_\_\_  
Surety Seal

By \_\_\_\_\_

Its By \_\_\_\_\_

Its \_\_\_\_\_

***ALL SIGNATURES MUST BE ACKNOWLEDGED BY A NOTARY PUBLIC.***

SURETY LABOR AND MATERIAL  
PAYMENT BOND

STATE OF HAWAI'I                    )  
  ) ss.  
COUNTY OF \_\_\_\_\_)

On this \_\_\_\_\_ day of \_\_\_\_\_, \_\_\_\_\_, before me appeared  
\_\_\_\_\_ to me personally known, who being by me was duly sworn, did say he/she is the \_  
\_\_\_\_\_ of \_\_\_\_\_, a \_\_\_\_\_; that the seal affixed to the  
foregoing instrument is the \_\_\_\_\_ seal of said \_\_\_\_\_; and said officer acknowledged said  
instrument to be the free act and deed of said \_\_\_\_\_.

\_\_\_\_\_  
Notary Public, State of Hawai'i

Name of Notary: \_\_\_\_\_

My commission expires: \_\_\_\_\_

***(SURETY PLEASE INSERT YOUR APPLICABLE NOTARY SECTION)***

**EXHIBIT A2**  
**LABOR AND MATERIAL PAYMENT BOND**  
(11/17/98)

**KNOW TO ALL BY THESE PRESENTS:**

That we, \_\_\_\_\_, as Contractor, hereinafter called Contractor, is held and firmly bound unto the \_\_\_\_\_, its successors and assigns, as Obligee, hereinafter called Obligee, in the amount of

\_\_\_\_\_

**DOLLARS (\$\_\_\_\_\_)**, lawful money of the United States of America, for the payment of which to the said Obligee, well and truly to be made, Contractor binds itself, its heirs, executors, administrators, successors and assigns, firmly by these presents. Said amount is evidenced by:

Legal tender;

Share Certificate unconditionally assigned to or made payable at sight to

\_\_\_\_\_

Description

\_\_\_\_\_;

Certificate of Deposit, No. \_\_\_\_\_, dated \_\_\_\_\_,  
issued by \_\_\_\_\_,  
drawn on \_\_\_\_\_,

a bank, savings institution or credit union insured by the Federal Deposit Insurance Corporation or the National Credit Union Administration, payable at sight or unconditionally assigned to

\_\_\_\_\_;

Cashier's Check No. \_\_\_\_\_, dated \_\_\_\_\_,  
issued by \_\_\_\_\_,  
drawn on \_\_\_\_\_,

a bank, savings institution or credit union insured by the Federal Deposit Insurance Corporation or the National Credit Union Administration, payable at sight or unconditionally assigned to

\_\_\_\_\_;

Teller's Check No. \_\_\_\_\_, dated \_\_\_\_\_,  
issued by \_\_\_\_\_,  
drawn on \_\_\_\_\_,

a bank, savings institution or credit union insured by the Federal Deposit Insurance Corporation or the National Credit Union Administration, payable at sight or unconditionally assigned to

\_\_\_\_\_  
Treasurer's Check No. \_\_\_\_\_, dated \_\_\_\_\_,  
issued by \_\_\_\_\_,  
drawn on \_\_\_\_\_;

a bank, savings institution or credit union insured by the Federal Deposit Insurance Corporation or the National Credit Union Administration, payable at sight or unconditionally assigned to

\_\_\_\_\_  
Official Check No. \_\_\_\_\_, dated \_\_\_\_\_,  
issued by \_\_\_\_\_,  
drawn on \_\_\_\_\_;

a bank, savings institution or credit union insured by the Federal Deposit Insurance Corporation or the National Credit Union Administration, payable at sight or unconditionally assigned to

\_\_\_\_\_  
Certified Check No. \_\_\_\_\_, dated \_\_\_\_\_,  
accepted by a bank, savings institution or credit union insured by the Federal Deposit Insurance Corporation or the National Credit Union Administration, payable at sight or unconditionally assigned \_\_\_\_\_;

WHEREAS:

The Contractor has by written agreement dated \_\_\_\_\_ entered into a contract with Obligee for the following PROJECT:

\_\_\_\_\_ hereinafter called Contract, which Contract is incorporated herein by reference and made a part hereof.

**NOW, THEREFORE,**

The condition of this obligation is such that, if Contractor shall promptly and faithfully perform the Contract in accordance with, in all respects, the stipulations, agreements, covenants and conditions of the Contract as it now exists or may be modified according to its terms, free from all liens and claims and without further cost, expense or charge to the Obligee, its officers, agents, successors or assigns, free and harmless from all suits or actions of every nature and kind which may be brought for or on account of any injury or damage, direct or indirect, arising or growing

out of the doing of said work or the repair or maintenance thereof or the manner of doing the same or the neglect of the Contractor or its agents or servants or the improper performance of the Contract by the Contractor or its agents or servants or from any other cause, and shall promptly pay all persons supplying labor and materials for the performance of the Contract, then this obligation shall be void; otherwise it shall be and remain in full force and effect.

**AND IT IS HEREBY STIPULATED AND AGREED** that suit on this bond may be brought before a court of competent jurisdiction without a jury, and that the sum or sums specified in the said Contract as liquidated damages, if any, shall be forfeited to the Obligee, its successors or assigns, in the event of a breach of any, or all, or any part of, the covenants, agreements, conditions, or stipulations contained in the Contract or in this bond in accordance with the terms thereof.

**AND IT IS HEREBY STIPULATED AND AGREED** that this bond shall inure to the benefit of any and all persons entitled to file claims for labor performed or materials furnished in said work so as to give any and all such persons a right of action as contemplated by Sections 103D-324(d) and 103D-324(e), Hawai'i Revised Statutes.

The amount of this bond shall be reduced by and to the extent of any payment or payments made in good faith hereunder, inclusive of the payment of mechanics' liens which may be filed of record against the PROJECT, whether or not claim for the amount of such lien be presented under and against this bond.

Signed this \_\_\_\_\_ day of \_\_\_\_\_, \_\_\_\_\_.

(Seal) \_\_\_\_\_  
Name of Contractor

\* \_\_\_\_\_  
Signature

\_\_\_\_\_  
Title

STATE OF HAWAI'I )  
 ) ss.  
COUNTY OF \_\_\_\_\_ )

On this \_\_\_\_\_ day of \_\_\_\_\_, \_\_\_\_\_, before me appeared \_\_\_\_\_ to me personally known, who being by me was duly sworn, did say he/she is the \_\_\_\_\_ of \_\_\_\_\_, a \_\_\_\_\_; that the seal affixed to the foregoing instrument is the \_\_\_\_\_ seal of said \_\_\_\_\_; and said officer acknowledged said instrument to be the free act and deed of said \_\_\_\_\_.

\_\_\_\_\_  
Notary Public, State of Hawai'i  
Name of Notary: \_\_\_\_\_  
My commission expires: \_\_\_\_\_

**(ALL SIGNATURES MUST BE ACKNOWLEDGED BY A NOTARY PUBLIC)**

**EXHIBIT B**  
**INSURANCE REQUIREMENTS**  
**BOARD OF WATER SUPPLY COUNTY OF KAUA'I**

Contractor shall procure and maintain, on primary basis and at its sole expense, at all times during the life of the contract insurance coverages, limits, including endorsements described herein against claims for injuries to persons or damages to property which may arise from or in connection with the performance of the work by the Contractor or the Contractor's agents, representatives, employees or subcontractors. The requirements contained herein, as well as the Department of Water, County of Kaua'i's (hereinafter "DOW") review or acceptance of insurance maintained by the Contractor is not intended to and shall not in any manner limit or qualify the liabilities or obligations assumed by the Contractor.

To the extent applicable, the amounts and types of insurance will conform to the minimum terms, conditions and coverage(s) of Insurance Service Office (ISO) policies, forms, and endorsements.

**A. General Conditions**

**Waiver of Subrogation.** Contractor shall agree by entering into a contract with the Board of Water Supply, County of Kaua'i (hereinafter "Board") to provide a Waiver of Subrogation for the Commercial General Liability, Automobile Liability, and Workers Compensation policies. When required by the insurer, or should a policy condition not permit Contractor to enter into a pre-loss agreement to waive subrogation without an endorsement, the Contractor shall agree to notify the insurer and request the policy be endorsed with a Waiver of Subrogation in favor of the Board. This Waiver of Subrogation requirement shall not apply to any policy, which includes a condition specifically prohibiting such an endorsement, or voids coverage should Contractor enter into such an agreement on a pre-loss basis.

**Subcontractors.** If applicable, Contractor shall include all subcontractors as additional insureds under its policies and shall retain the records of the separate certificates and endorsements for each subcontractor. All coverages for subcontractors shall be subject to the same requirements as the Contractor as stated herein.

APPLICABLE

NOT APPLICABLE

**Additional Insured.** Contractor shall agree to endorse the **BOARD OF WATER SUPPLY, COUNTY OF KAUA'I as an Additional Insured** with a CG026 Additional Insured – Designated Person or Organization endorsement, a copy of the applicable policy language, or similar endorsement to all required insurance policy(ies), except for Workers Compensation and Professional Liability.

**Deductibles and Self-Insured Retentions.** Any deductibles or self-insured retentions must be declared to and approved by the DOW. At the option of the DOW, either: the insurer shall reduce or eliminate such deductibles or self-insured retentions as respects the Board; or the Contractor shall provide a financial guarantee (audited financial statement) satisfactory to the Department guaranteeing payment of losses and related investigations, claim administration and defense expenses.

When a self-insured retention (SIR) or deductible exceeds \$50,000, the Department reserves the right, but not the obligation, to review and request a copy of the Contractor's most recent annual report or audited financial statement.

**Contractor's Responsibility.** The Contractor is responsible for paying any portion of any loss not covered because of the operation of any deductible, co-insurance clause or self-insured retention applicable to the insurance required herein. If the Board is damaged by the failure of the Contractor to maintain insurance as required in this paragraph, then the Contractor shall bear all reasonable costs properly attributable to that failure.

**Primary and Non-contributory.** All policies required of the Contractor will be endorsed as primary and any insurance or self-insurance program maintained by the Board shall be non-contributory.

**Certificate of Insurance.** Concurrent with the execution of the contract, Contractor shall provide the Department a certificate of insurance completed by a duly authorized representative of their insurer certifying that the liability coverage(s) is written on an occurrence form. Immediately upon becoming aware that its insurance will be cancelled, non-renewed, or materially changed, Contractor will notify Department by providing written notice.

The Certificate Holder address shall read:

**Board of Water Supply, County of Kaua'i**  
4398 Pua Loke Street, Lihue, HI 96766  
Attention: ( \_\_\_\_\_ Name of Contact Person)  
Contract No. \_\_\_\_\_  
Project Title \_\_\_\_\_

Concurrent with the execution the contract the Contractor shall furnish the Department with original certificates and endorsements effecting required coverage(s). The Department reserves the right to require complete copies of all required insurance policies, including the policy declarations and endorsements affecting the coverage at any time.

Failure to secure and maintain the required insurance shall be considered as a material breach of the contract. Should the Board be forced to expend funds that would have been covered under the specified insurance, Contractor shall reimburse the Board for such funds. In the event the Board determines, in its sole and absolute discretion, that it is necessary to purchase the coverages herein required of the Contractor, and which the Contractor has failed to secure, the Contractor shall reimburse the Board for the expenditure of such funds.

**Right to Revise or Reject.** Department reserves the right, but not the obligation, to review and revise any insurance requirement, not limited to limits, coverages and endorsements based on insurance market conditions affecting the availability or affordability of coverage; or changes in the scope of work or specifications affecting the applicability of coverage. Additionally, the Department reserves the right, but not the obligation, to review and reject any insurance policies failing to meet the criteria stated herein or any insurer providing coverage due to its poor financial condition or failure to operate legally.

**B. Minimum Insurance Coverage Requirements**

Unless otherwise approved by the Manager and Chief Engineer, the policy or policies of insurance maintained by the Contractor shall provide the following minimum limit(s) and coverage(s) as specified herein and be placed with an insurance carrier authorized to do business in the State of Hawaii and rated A-VII by A.M. Best:

**Commercial General Liability.** The Contractor shall procure and maintain Commercial General Liability, with dedicated required limits, as set forth herein, written on occurrence form providing:

Designated premises basis

**OR**

Per Project basis

The coverages shall include the following:

- Premises Operations
- Independent Contractors
- Products and Completed Operations
- Broad Form Property Damage including completed operations
- Blanket Contractual Liability
- Personal Injury
- Employees named as Additional Insured
- Severability of Interest
- Explosion, Collapse and Underground Property Damage

The minimum limits of liability may be satisfied by providing either:

<b>Bodily Injury and Property Damage Combined Single Limit:</b> <input type="checkbox"/> \$2,000,000 per occurrence <input type="checkbox"/> \$2,000,000 annual aggregate	<b>OR</b>	<b>Personal Injury:</b> <ul style="list-style-type: none"> <li>▪ \$1,000,000 per occurrence</li> <li>▪ \$2,000,000 annual aggregate</li> </ul> <b>AND</b> <b>Products and Completed Operations:</b> <ul style="list-style-type: none"> <li>▪ \$1,000,000 per occurrence</li> <li>▪ \$2,000,000 annual aggregate</li> </ul>
---	-----------	---



Contractor must provide evidence the Board is an Additional Insured for Products/Completed Operations coverage for both ongoing operations and after substantial completion of the work. This coverage may be provided by the ISO form CG 2010 (11 85) or an equivalent policy form. Coverage provided by a non-equivalent CGL form shall be specifically endorsed providing both the course of construction and products/completed operations. ISO CG 2010 (04 13) and ISO form CG 2037 (04 13) or an equivalent form is required from the Contractor. The Contractor and subcontractor(s), if any, shall provide evidence to the Department on an annual basis the products/completed operation coverage is in effect for two (2) years after substantial completion of the project.

- Business Automobile Liability.** The Contractor shall procure and maintain Business Automobile Liability written on occurrence form for all Owned, Non-owned, and Hired automobiles. If the Contractor does not own automobiles, Contractor shall agree to maintain coverage for Hired & Non-Owned Auto Liability, which may be satisfied by way of endorsement to the Commercial General Liability policy or separate Business Automobile Liability. Coverage shall be for automobile contractual liability, uninsured and underinsured motorist coverage, basic no-fault, and personal injury protection, as required by Hawai'i law with the following limits:

**Bodily Injury**  
\$1,000,000 per person  
\$1,000,000 per occurrence  
**Property Damage**  
\$1,000,000 per accident

- Workers' Compensation and Employer's Liability.** The Contractor shall procure and maintain at all times during the term of the contract the following insurance liability coverage: Workers' Compensation, Temporary Disability Insurance (TDI), and similar insurance that is required by the State of Hawai'i or federal laws. Self-insurance is permitted subject to submission of a copy of the appropriate governmental authorization and qualification by the Contractor and subcontractor(s).  
The minimum limits of liability to be maintained are as follows:

**Coverage A: State of Hawai'i Workers' Compensation Law:**  
Statutory Limits.

**Coverage B: Employer's Liability:**  
Bodily Injury from each accident \$1,000,000  
Bodily Injury from disease \$1,000,000  
Bodily Injury from disease aggregate \$1,000,000

- Builder's Risk.** The Contractor shall procure and maintain an Inland Marine Builder's Risk policy providing coverage to protect the interests of the Board, Contractor, sub-contractors, architects, and engineers, including property in transit and property on or off- premises, which shall become part of the building, or Project. Coverage shall be written on an **All Risk, Replacement Cost, and Completed Value Form** basis in an amount at least equal to 100% of the projected completed value of the Project as well as subsequent modifications of that sum, unless an agreed amount is otherwise stated between the Department and the Contractor. The policy shall insure all work, labor, and materials furnished by the Contractor and the Contractor's subcontractors against loss occasioned by fire, lightning, windstorm, theft, vandalism, malicious mischief, flood, earthquake, and collapse.

The amount of coverage for the perils of flood and earthquake may be subject to a sub-limit. The sub-limit shall provide coverage of at least 25% of the full replacement cost.

The policy shall also include coverage for debris removal and reasonable compensation for architect's and engineer's services and expenses required as a result of an insured loss. The Contractor shall endorse the policy with a manuscript endorsement eliminating the automatic termination of coverage in the event the building is occupied in whole or in part, or put to its intended use, or partially accepted by the Department. The manuscript endorsement shall amend the automatic termination clause to only terminate coverage if the policy expires, is cancelled, the Board's interest in the building ceases, or the building is accepted or insured by the Board.

The Contractor shall name the Board of Water Supply, County of Kaua'i as a loss payee on the Builder's Risk policy.

**Installation Floater.** The Contractor shall procure and maintain an Installation Floater policy providing coverage to protect the interests of the Board, Contractor, sub-contractor(s), architects, and engineers, including property in transit and property on or off-premises, which shall become part of the project.

Coverage shall be written on an All Risk, Replacement Cost, and Completed Value Form basis in an amount at least equal to 100% of the projected completed value of the Project as well as subsequent modifications of that sum, unless an agreed amount is otherwise stated between the Department and the Contractor. The policy shall insure all work, labor, and materials furnished by the Contractor and the Contractor's subcontractors against loss occasioned by fire, lighting, windstorm, theft, vandalism, malicious mischief, flood, earthquake, and collapse.

The amount of coverage for the perils of flood and earthquake may be subject to a sub-limit. The sub-limit shall provide coverage of at least 25% of the full replacement cost.

The policy shall also include coverage for debris removal and reasonable compensation for architect's and engineer's services and expenses required as a result of an insured loss. The Contractor shall endorse the policy with a manuscript endorsement eliminating the automatic termination of coverage in the event the building is occupied in whole or in part, or put to its intended use, or partially accepted by the Department. The manuscript endorsement shall amend the automatic termination clause to only terminate coverage if the policy expires, is cancelled, the Board's interest in the building ceases, or the building is accepted or insured by the Board.

The Contractor shall name the Board of Water Supply, County of Kaua'i as a loss payee on the Installation Floater policy.

**Professional Liability (Errors and Omissions).** The Contractor and its subcontractors shall procure and maintain Professional Liability Insurance (Errors and Omissions Insurance) that covers all such activities under the contract. Such insurance shall have these minimum limits and coverage(s):

\$1,000,000 per occurrence  
\$2,000,000 annual aggregate

For policies written on a "Claims-Made" basis, Contractor warrants the retroactive date equals or precedes the effective date of the contract. In the event the policy is canceled, non-renewed, switched to an Occurrence Form, retroactive date advanced; or any other event triggering the right to purchase a Supplemental Extended Reporting Period (SERP) during the life of the contract, Contractor shall agree to purchase Supplemental Extended Reporting Period (SERP) with a minimum reporting period not less than **two (2)** years.

The requirement to purchase a SERP shall not relieve Contractor of the obligation to provide replacement coverage.

**Pollution Legal Liability.** The Contractor shall procure and maintain Pollution Liability or similar Environmental Impairment Liability at a minimum limit not less than:

\$1,000,000 per occurrence  
\$2,000,000 annual aggregate

The policy shall provide coverage for damages against, but not limited to, third-party liability, clean-up, corrective action including assessment, remediation and defense costs.

**Contractor's Pollution Liability.** Contractor shall procure and maintain pollution liability insurance when the Scope of Work involves removal, abatement, encapsulation or other treatment, disposal or remediation of asbestos or other hazardous materials or an exposure to pollutants or impairment of the environment. The policy shall provide coverage for third party liability, clean-up, and corrective action including assessment remediation and defense costs. The policy may be written on either an occurrence form or claims made. The minimum limits of liability shall be:

\$1,000,000 per occurrence  
\$2,000,000 annual aggregate

**Crime Insurance or Commercial Fidelity Bond:** Contractor shall procure and maintain Commercial Crime Insurance or Fidelity Bond providing Employee Dishonesty on a blanket basis covering all of the Contractor's employees with a minimum amount of insurance at least equal to the amount of the contract. The policy shall be endorsed to cover "Third-Party Liability" including a third-party beneficiary clause in favor of the Board. The policy shall include a minimum twelve (12) month "Discovery Period" when written on a Loss Sustained basis.

**Property.** The Tenant or Lessee, shall agree to maintain property insurance including flood and windstorm written on a replacement cost basis in an amount not less than 100% of the replacement cost of the building(s) and contents, including betterments and improvements made by the Tenant or Lessee, located on the premises. Contractor shall agree to be fully responsible for any deductible or self-insured retention, and to provide this coverage on primary basis.

**Umbrella or Excess Liability.** Contractor may satisfy the minimum liability limits required above under an Umbrella or Excess Liability policy with \$1,000,000 per occurrence and \$2,000,000 aggregate. If Contractor is using its Umbrella or Excess Liability Insurance policy to satisfy the minimum requirements, Contractor shall agree to endorse the Board of Water Supply, County of Kaua'i as "Additional Insured" on the Umbrella or Excess Liability policy, or shall confirm in writing that its Umbrella or Excess Liability policy "follows form."

CONTRACT (EXHIBIT J)

## EXHIBIT K - CONTRACT CHANGE ORDER

### CONTRACT CHANGE ORDER DEPARTMENT OF WATER COUNTY OF KAUAI

Project						Order No.		
						Date		
Project No.		Change Requested By:			Contract No.			
To _____, Contractor:								
Estimate of Quantities and Costs:								
Item No.	Item	Quantity	Unit	Contract Unit Price	Agreed Unit Price	\$ Amount (+ or -)		
CONTRACT PRICE			CONTRACT CERTIFICATION			CONTRACT TIME		
<input type="checkbox"/> No Change <input type="checkbox"/> Increased by \$ _____ <input type="checkbox"/> Decreased by \$ _____			Amount Certified \$ _____ New Contract Price \$ _____			<input type="checkbox"/> No Change <input type="checkbox"/> Increased by _____ Calendar days <input type="checkbox"/> Decreased by _____ Calendar days		
Submitted by:			Approved:			Accepted:		
Project Engineer		Date	Fiscal Officer		Date			
ED&C Division Head		Date	Mgr & Chief Engineer		Date			
<p>This Change Order No. __ is issued pursuant to the Contract and, upon execution, shall become incorporated in the Contract. The amount set forth in this Change Order comprises the total compensation due the Contractor, all Subcontractors, and all Suppliers, for any work performed under this Change Order, including impact on unchanged work. The signing of this Change Order indicates that the Change Order constitutes full mutual accord and satisfaction for the contract including any change and that the charge under this Change Order constitutes the total equitable adjustment owed the Contractor, all Subcontractors, and all Suppliers under this contract. Any future dispute regarding time required for performance or contract price as related to this Change Order is subject to the terms of the General Provisions for Construction Contracts of the Department of Water, County of Kaua'i as amended and Hawai'i Revised Statutes and Hawai'i Administrative Rules.</p>								
Accepted:								
Contractor		Title				Date		

CONTRACT CHANGE ORDER (EXHIBIT K)

# EXHIBIT L – CONTRACT MODIFICATION FORM

## CONTRACT MODIFICATION FORM (11/15/11)

DEPARTMENT OF WATER  
COUNTY OF KAUAI  
STATE OF HAWAII

MODIFICATION ORDER NO. \_\_\_\_\_ Date \_\_\_\_\_

Contractor \_\_\_\_\_ Contract No. \_\_\_\_\_

Contract Title \_\_\_\_\_

### A. MODIFICATIONS

The following modifications are to be performed in accordance with all contract stipulations (specifications, delivery point, rate of delivery, period of performance, price, quantity, or other provisions by mutual action of the parties to the contract.)

\_\_\_\_\_  
\_\_\_\_\_  
\_\_\_\_\_  
\_\_\_\_\_

### B. CONTRACTOR'S QUOTATION

The modifications described in "A" above will be performed at a contract price \_\_\_\_ increase \_\_\_\_ decrease of \$ \_\_\_\_\_. Contractor will not undertake to perform the changes in "A" above until this modification order has been approved and issued.

\_\_\_\_\_  
Contractor's Signature and Date

### C. STATEMENT OF CONTRACT FUNDS

Original Contract Price \$ \_\_\_\_\_

Previous Adjusted Contract Price \$ \_\_\_\_\_

Amount this Change: Plus \_\_\_\_ Minus \_\_\_\_\_

New Adjusted Contract Price \$ \_\_\_\_\_

### D. VALIDATION OF CONTRACT MODIFICATION

\_\_\_\_\_  
Dept. of Water Date

\_\_\_\_\_  
Manager & Chief Engineer Date

DISTRIBUTION: Original - Contracting Office c: Contractor

CONTRACT MODIFICATION FORM (EXHIBIT L)

**EXHIBIT M – AS BUILT INFORMATION REQUIRED**  
**AS-BUILT INFORMATION REQUIRED**

**A. As-built information for Waterlines**

1. Note any changes in alignment and grade.
  - a. Reference alignment change to baseline or original waterline alignment.
2. Note the cover and existing waterlines (when exposed) and at connection areas.
3. Note the brand and model no. of the following:
  - a. Fire Hydrants
  - b. Valves
  - c. A.C. pipe
  - d. D.I. pipe
  - e. Backflow Preventers (also note down the serial number)
4. Count the number of turns required to open each valve.
  - a. Note this down in the as-builts and write in the date that this was checked.
5. Reference the location of all valves.
  - a. Use the best available reference points.
  - b. If a power pole is used, note down the pole number.
  - c. Use at least two (2) reference points per valve
  - d. Examples of reference points.
    - i. Fire hydrant
    - ii. Water meter box
    - iii. ARV box
    - iv. Cleanout box
    - v. Power pole
    - vi. Street light base
    - vii. Guy wire anchor
    - viii. Street Monument
    - ix. Corner of catch basin
    - x. Drainage structures
    - xi. Manhole Cover
    - xii. Street Signs
    - xiii. Bridge abutments
    - xiv. Corner of a building
    - xv. Any reasonably permanent object
6. Reference hydrant valves to at least two (2) other reference points in addition to the distance from the hydrant head.
  - a. If the hydrant gets knocked down by a vehicle and doesn't get replaced until later, and in the meantime, if the State or County repaves the roadway and the roadway and the hydrant bury gets overgrown with vegetation, Operations can locate the hydrant valve by measuring from the reference points.

AS-BUILT INFORMATION REQUIRED (EXHIBIT M)

## **B. As-built information for Service Laterals**

1. When a new service lateral is installed away from the property corners, measure the distance from the nearest property corner to the meter box.
2. When the existing service laterals are not located at the property corners, measure the distance from the nearest property corner to the existing meter boxes.
  - a. Write down the meter numbers for the existing meter(s).
3. Measure the distance from the angle valve to the waterline at cul-de-sacs and along curves
4. Detector Checks and Compound Meter Laterals
  - a. Verify that the meter spool cannot flow water through the lateral.

## **C. As-built Drawing Information for Pumping Stations**

1. Depth to bottom of well
  - a. Usually measured with a bailer
2. Depth of static water level
  - a. Use well sounder
3. Length and diameter of discharge columns installed
4. Length of pump bowls
5. Length of strainer
6. Location of the bottom of the airline
  - a. Usually placed at the top of the pump coupling
  - b. The bottom of the airline should be beveled at a 45-degree angle
7. Pump data
  - a. Brand, serial number, model number, number of stages.
8. Take meggar readings when installing submersible pumps
9. Motor data
  - a. Write down the nameplate data and space heater serial number on the as-built plans
10. Record the nameplate data for:
  - a. Booster pumps
  - b. Chlorinator booster pumps
  - c. Air compressors

## **D. As-built Information for Water Tanks**

1. Reference the location of the splices along the water stop.

## EXHIBIT N – BMP INSPECTION FORM

Department of Water  
County of Kauai  
Lihue, Kauai, Hawaii

### Site Specific Construction Best Management Practices Inspection Form

Job No.: \_\_\_\_\_ Water Plan 2020 No.: \_\_\_\_\_ NGPC File No.: \_\_\_\_\_

Project Title: \_\_\_\_\_

Date: \_\_\_\_/\_\_\_\_/\_\_\_\_ Weather: \_\_\_\_\_

DOW Inspector: \_\_\_\_\_

Duly Authorized Representative: \_\_\_\_\_ Contractor: \_\_\_\_\_

Site Specific Construction Best Management Practices (SSCBMPs) Plan	Yes	No	N/A	Date Corrected	Notes*
Is a copy of the SSCBMP plan available at the site?					
Is the SSCBMP plan certified, signed and dated?					
Is the SSCBMP pan current and up-to-date?					
Are accompanying erosion and sediment control (ESC) drawings available at the site?					
Are the ESC drawings up-to-date?					
Are all NGPCs available at the site?					
Are inspection records available at the site?					



Best Management Practices	Location	Installed per Specification (Y/N)	Adequate	Needs maintenance	N/A	Date Corrected	Notes*
Storm Water Run On (SSCBMP Section 3.1)							
Vegetated Diversion Ditches							
Soil Stabilization (SSCBMP Section 3.2)							
n/a							

Best Management Practices	Location	Installed per Specification (Y/N)	Adequate	Needs maintenance	N/A	Date Corrected	Notes*
Slope Protection (SSCBMP Section 3.3)							
Erosion Control Mats							
Storm Drain Inlet Protection (SSCBMP Section 3.4)							
Mulch socks at all active inlets							
Perimeter Controls and Sediment Barriers (SSCBMP Section 3.5)							
Silt Fence							
Mulch socks							
Sediment Basins and Detention Ponds (SSCBMP Section 3.6)							
Sed Basin							
Stabilized Ingress/Egress (SSCBMP Section 3.7)							
Stabilized egress							
Signage for entrance only							
Signage for exit only							
Additional Erosion and Sediment Control BMPs (SSCBMP Section 3.8)							
Mirafi over soil stockpile							
Material Handling and Waste Management (SSCBMP Section 3.9)							

Bins for Trash							
Baseyards/Staging Areas (SSCBMP Section 3.10)							
Store paint/resin/plaster in container							
Silt Fence							
Wash out Areas (SSCBMP Section 3.11)							
Concrete Washout Container							
Concrete Washout Container							
Proper Equipment/Vehicle Fueling and Maintenance Practices (SSCBMP Section 3.12)							
Lined pit under diesel tank							
Spill kit next to diesel tank							
Additional Non-Erosion or Sediment Control BMPs (SSCBMP Section 3.13)							

Best Management Practices	Location	Installed per Specification (Y/N)	Adequate	Needs maintenance	N/A	Date Corrected	Notes*
Post Construction BMPs (SSCBMP Section 3.14)							
Other							

\* Attached additional sheet for notes if necessary

Site Conditions	Yes	No	N/A	Notes and Corrective Actions
-----------------	-----	----	-----	------------------------------

Are Off-site flows entering the construction site?				
Is there evidence of polluted discharges off the site?				
Is there evidence of polluted discharges from the site to a state water (e.g. storm drain, ditch, stream, ocean)?				
Is repair, maintenance, or installation of sediment control BMPs needed at the site?				
Is repair, maintenance, or installation of erosion control BMPs needed at the site?				
Are construction materials/debris/trash/soil stored or disposed of properly on site?				
Is there vehicle tracking from the site to receiving streets?				
Do locations exist where additional or revised BMPs are needed?				
Do locations exist where BMPs may no longer be necessary and may be removed?				
Does your site evaluation indicate a need to update or revise the current SSCBMP plan and/or accompanying erosion and sediment control drawings?				

Pictures taken during the SSCBMP inspection documented above are attached.

YES

NO

I certify under penalty of law that this document and all attachments were prepared under my direction or supervision in accordance with a system designed to assure that qualified personnel properly gather and evaluate the information submitted. Based on my inquiry of the person or persons who manage the system, or those persons directly responsible for gathering the information, the information submitted is, to the best of my knowledge and belief, true, accurate, and complete. I am aware that there are significant penalties for submitting false

information, including the possibility of fine and imprisonment for knowing violations.

---

Duly Authorized Representative    Printed Name

---

Duly Authorized Representative    Signature    Date

\* Duly Authorized Representative as submitted to DOH for NPDES permit

As an inspector, acting on behalf of the Department of Water, County of Kauai, I certify, to the best of my knowledge and belief, that the inspection verified the compliance of the approved and/or amended site specific BMP plan. All other requirements of the NPDES permit approval are the sole responsibility of the contractor, who is the independent contractor, hired to act as a duly authorized representative of the Kauai Department of Water, and I shall not be personally liable for any violations to the approved permit conditions.

---

DOW Inspector Printed Name

---

DOW Inspector Signature    Date

**EXHIBIT O – EMPLOYMENT OF STATE RESIDENTS COMPLIANCE FORM**

**CERTIFICATION OF COMPLIANCE  
FOR  
EMPLOYMENT OF STATE RESIDENTS  
ACT 68, SESSION LAWS OF HAWAII 2010**

Project Title: \_\_\_\_\_

Agency Project No.: \_\_\_\_\_

Contract No.: \_\_\_\_\_

As required by Act 68, Session Laws of Hawai'i 2010-Employment of State Residents on Construction Procurement Contracts, I hereby certify under oath, that I am an officer of \_\_\_\_\_ and for the month of \_\_\_\_\_, 20\_\_\_\_, \_\_\_\_\_ is in compliance with Act 68, SLH 2010, by employing a workforce of whom not less than eighty percent are Hawai'i residents, as calculated according to the formula in the solicitation, to perform this Contract.

- I am an officer of the **Contractor** for this contract.
- I am an officer of a **Subcontractor** for this contract.

*CORPORATE SEAL*

\_\_\_\_\_  
(Name of Company)

\_\_\_\_\_  
(Signature)

\_\_\_\_\_  
(Print Name)

\_\_\_\_\_  
(Print Title)

Subscribed and sworn to me before this \_\_\_\_ day of \_\_\_\_\_, 20\_\_\_\_.

Doc. Date: \_\_\_\_\_ # Pages: \_\_\_\_\_

Name of Notary: \_\_\_\_\_, \_\_\_\_ Circuit

\_\_\_\_\_  
Notary Public, \_\_\_\_ Circuit, State of Hawai'i

Doc. Description: \_\_\_\_\_

My Commission Expires: \_\_\_\_\_

\_\_\_\_\_  
Notary Signature Date

**NOTARY CERTIFICATION**

EMPLOYMENT OF STATE RESIDENTS COMPLIANCE FORM (EXHIBIT O)

# EXHIBIT P – REQUEST FOR INFORMATION (RFI) FORM

## RFI

To: Dustin Moises, P.E.  
Kauai Department of Water  
4398 Pua Loke Street  
Lihue, HI 96766

RFI #:  
Date:  
Job No.:  
Contractor Phone:  
Contractor email:

CC:

Subject:

Drawing Sheet #:  
Specification Section:  
Cost Impact:  
Schedule Impact:

Request:
Requested by: _____
Date response required: _____

Response:
Answered by: _____
Company: _____
Date: _____

REQUEST FOR INFORMATION (RFI) FORM (EXHIBIT P)

APPENDIX C: Offer.

Contractor \_\_\_\_\_

OFFER

For

DEPARTMENT OF WATER, COUNTY OF KAUA‘I,  
LĪHU‘E, KAUA‘I, HAWAI‘I

\_\_\_\_\_ 20 \_\_\_\_\_

Manager and Chief Engineer  
Department of Water  
County of Kaua‘i  
4398 Pua Loke Street  
Līhu‘e, Hawai‘i 96766

Dear Sir:

Pursuant to and in compliance with your Invitation For Bids and other Contract Documents relating thereto, the undersigned Offeror, having familiarized itself with the terms of the contract, the local conditions affecting the performance of the contract and the cost of the work at the place where the work is done, the plans and specifications, “General Provisions for Construction Contracts of the Department of Water”, “Water System Standards, 2002”, Invitation For Bids, and other Contract Documents, hereby proposes and agrees to perform, within the time stipulated in the said documents, including all its component parts and everything required to be performed, and to provide and furnish any and all of the labor, materials, tools, expendable equipment, and all utility and transportation services necessary to perform the contract, in a workmanlike manner, in place complete all of the work covered by the contract in connection with these specifications and accompanying construction plans titled:

**JOB NO. 17-10, WP2020 Project No. KW-07 Rehabilitate Paua Valley Tank No. 1, 0.5 MG Concrete, Kekaha Water System, KAUA‘I, HAWAI‘I**

on file in the office of the Department of Water for,

TOTAL SUM OFFER \_\_\_\_\_ DOLLARS  
(words)

(\$ \_\_\_\_\_) said total sums being itemized on the following pages:



## OFFER SCHEDULE

JOB NO. 17-10, WP2020 Project No. KW-07, KAUA'I, HAWAII

ITEM NO.	ESTIMATED QUANTITY	DESCRIPTION	UNIT PRICE	TOTAL
1 (000931)	1	<b>Lump Sum.</b> Removal and disposal of lead-containing and lead-based paint (LCP/LBP), Polychlorinated Biphenyl (PCB) in accordance with the specifications, including air monitoring, TCLP testing, all incidentals, disposal as hazardous waste at an approved EPA disposal site, all in accordance with the plans and specifications.		\$
2 (000932)	1	<b>Lump Sum.</b> Install fluid-applied roofing system on reservoir roof, including surface preparation, membrane flashing and all appurtenant work, in place complete, including removing of the existing roofing system to the original concrete slab surface including loading, hauling and disposal and all incidentals, all in accordance with the plans and specifications.		\$
3 (000933)	100	<b>Lineal Feet.</b> Reservoir roof crack repair for concrete surfaces by routing and packing with crystalline mortar at exterior surface including surface preparation and curing of repairs and all incidentals, all in accordance with the plans and specifications, in place complete.	\$	\$
4 (000934)	30	<b>Square Feet.</b> Spall repairs at reservoir interior of underside of concrete roof slab, including surface preparation and curing of repairs and all incidentals, all in accordance with the plans and specifications, in place complete.	\$	\$
5 (000935)	1	<b>Lump Sum.</b> Install wall base joint sealant system, all appurtenances, in place complete, including removal of existing wall base joint sealant around entire perimeter of reservoir, and wall base joint leak test, all in accordance with the plans and specifications, in place complete.		\$



ITEM NO.	ESTIMATED QUANTITY	DESCRIPTION	UNIT PRICE	TOTAL
6 (000936)	1	<b>Lump Sum.</b> Sampling, testing and report results of the existing wall base joint sealant for PCB, in accordance with the plans and specifications.		\$
7 (000937)	1	<b>Lump Sum.</b> Install interior coating of walls, pipe exteriors, floor and columns, all appurtenances, including surface preparation, all in accordance with the plans and specifications, in place complete.		\$
8 (000938)	150	<b>Lineal Feet.</b> Reservoir wall crack repair for concrete surfaces by routing and packing with crystalline mortar at exterior surface and interior repairs including surface preparation and curing of repairs and all incidentals, all in accordance with the plans and specifications, in place complete.	\$	\$
9 (000939)	1	<b>Lump Sum.</b> Paint reservoir exterior wall, bottom of roof overhang, and all accessories with paint finish, including reservoir hatch, ladder, and railing, inclusive of paint removal, surface preparation, caulking and sealants and all incidentals, all in accordance with the plans and specifications, in place complete.		\$
10 (000940)	1	<b>Lump Sum.</b> Install level indicator system, all appurtenances and incidentals, all in accordance with the plans and specifications, in place complete.		\$
11 (000941)	1	<b>Lump Sum.</b> Cleaning, leak testing, and disinfection of reservoir interior with EPA oversight, all in accordance with the plans and specifications.		\$
12 (000155)	275	<b>Square Yards.</b> Removal of existing AC pavement for 12 feet around reservoir, including loading, hauling and disposal and all incidentals, all in accordance with the plans and specifications.	\$	\$
13 (000354)	335	<b>Square Yards.</b> Install AC pavement and underlayment, including subgrade preparation and all incidentals, all in	\$	\$

ITEM NO.	ESTIMATED QUANTITY	DESCRIPTION	UNIT PRICE	TOTAL
		accordance with the plans and specifications, in place complete,		
14 (000515)	1	<b>Lump Sum.</b> Install temporary erosion control measures, inclusive of silt fence, maintenance of erosion control BMP's, and other appurtenant work, all in accordance with the plans and specifications, in place complete.		\$
15 (000945)	1	<b>Lump Sum.</b> Install temporary PCB filtration system for discharging of reservoir water, inclusive of the installation of the Activated Carbon Filter Drums, piping, sump pump, excavation for containment pit and liner, and other appurtenant work and incidentals, including disassembling piping system, TCLP testing of (2) filter drums and drum disposal, backfill and compaction of pit, all in accordance with the plans and specifications, in place complete.		\$
16 (000946)	1	<b>Lump Sum.</b> Remove the existing interior ladder and install new stainless steel ladder and all incidental work, all in accordance with the plans and specifications, in place complete.		\$
		<b>TOTAL SUM OFFER (Items 1 to 16 inclusive)</b>		\$



SCHEDULE B  
HAWAI'I PRODUCTS PREFERENCE

In accordance with HRS §103D-1002, the Hawai'i products preference is applicable to this solicitation. Hawai'i Products ("HP") are available for those items noted on Schedule B, below. The Hawai'i products list is available on the SPO webpage at [www.spo.hawaii.gov/for-state-county-personnel/manual/procurement/solicitation/goods-services-construction/preferences/hawaii-product-preferences/](http://www.spo.hawaii.gov/for-state-county-personnel/manual/procurement/solicitation/goods-services-construction/preferences/hawaii-product-preferences/) or go to the SPO Home page, click on "For Vendors" tab; click on Preferences, Hawai'i Product Preferences to view. Offeror transmitting a Hawai'i Product (HP) shall identify the HP on Schedule B-1.

Any person desiring a Hawai'i product preference shall have the product(s) certified and qualified if not currently on the Hawai'i products list, prior to the deadline for receipt of offer(s) specified in the procurement notice and solicitation. The responsibility for certification and qualification shall rest upon the person requesting the preference. Persons desiring to qualify their product(s) not currently on the Hawai'i product list shall complete form SPO-038, Certification for Hawai'i Product Preference and submit, via email to the Procurement Officer issuing the solicitation, and provide the solicitation number and title in the subject line, and include all additional information required by the Procurement Officer. For each product, one form shall be completed and transmitted (i.e. 3 products should have 3 separate forms completed). Form SPO-038 is available on the SPO webpage at <http://hawaii.gov/spo> under the 'Quicklinks' menu; click on 'Forms for Vendors, Contractors, and Service Providers'.

When a solicitation contains both HP and non-HP, then for the purpose of selecting the lowest bid or purchase price only, the price offered for a HP item shall be decreased by subtracting 10% for the class I or 15% for the class II HP items offered, respectively. The lowest total offer, taking the preference into consideration, shall be awarded the contract unless the offer provides for additional award criteria. The contract amount of any contract awarded, however, shall be the amount of the price offered, exclusive of the preferences.

Change in Availability of Hawai'i product. In the event of any change that materially alters the Offeror's ability to supply Hawai'i products, the Offeror shall notify the Procurement Officer in writing no later than five (5) working days from when the Offeror knows of the change and the parties shall enter into discussions for the purposes of revising the contract or terminating the contract for convenience.

The following is a list of products that the Department anticipates will be used in this particular project; however the list is not all inclusive and additional products may be qualified.

HAWAI'I PRODUCTS LIST

HP Description	Manufacturer/Supplier	Class
----------------	-----------------------	-------



Bidders intending to use or supply a Hawai'i Product must list the price and total cost of each item f.o.b. jobsite, unloaded, including applicable general excise tax and use tax on this form. Failure to designate a Hawai'i product will mean that the Bidder is offering a non-Hawai'i product and award, if made to the bidder, will be on the basis that the bidder will deliver or use a non-Hawai'i product.

The Bidder shall list only the Manufacturers/Suppliers certified and qualified on Schedule B.

If the Department has awarded a contract under HRS, § 103D-1002, finds that in the performance of that contract there has been a failure to comply with HRS, § 103D-1002, the contract shall be voidable and the findings shall be referred for debarment or suspension proceedings under HRS 103D-702. Any purchase made or any contract awarded or executed in violation of this section shall be void and no payment shall be made by the Department on account of the purchase or contract.



SCHEDULE B-1  
SCHEDULE OF MATERIAL COST  
*(if Hawai'i preference requested)*

HAWAI'I PRODUCT	MANUFACTURER	CLASS	APPROX. QUANTITY	UNIT	TOTAL COST OF MATERIAL
Aggregates and Sand – Basalt, rock, cinder, limestone and coral					
Aggregates – Recycled asphalt and concrete					
Asphalt and paving materials					
Cement and concrete products					
Pre-cast concrete products					
Signs–traffic, regulatory and construction					
Soil amendments, mulch, compost					



SCHEDULE C  
MANDATORY LICENSING REQUIREMENT

“A” general engineering contractors and “B” general building contractors are reminded that due to the Hawai‘i Supreme Court’s January 28, 2002 decision in Okada Trucking Co., Ltd. V. Board of Water Supply, et al., 97 Haw. 450 (2002), they are prohibited from undertaking any work, solely or as part of a larger project, that would require the general contractor to act as a specialty contractor in any area in which the general contractor has no license. Although the “A” and “B” contractor may still submit an offer on and act as the “prime” contractor on an “A” and “B” project (*See, HRS § 444-7 for the definitions of an “A” and “B” project.*), respectively, the “A” and “B” contractor may only perform work in the areas in which they have the appropriate “C” specialty contractor’s license (*An “A” or “B” contractor obtains “C” specialty contractor’s licenses either on its own, or automatically under HAR § 16-77-32.*). The remaining work must be subcontracted out to appropriately licensed “C” specialty contractors. It is the sole responsibility of the contractor to review the requirements of this project and determine the appropriate licenses that are required to complete the project.

LISTING OF SUBCONTRACTORS

Sec. 103D-302, H.R.S., provides that each offer for Public Works Construction Contracts shall include the name of each person or firm to be engaged by the Offeror as a joint contractor or subcontractor in the performance of the Public Works Construction Contract. The Offer shall also indicate the nature and scope of the work to be performed by such joint contractors or subcontractors. All offers which do not comply with this requirement shall be rejected pursuant to Sec. 103D-302(b) H.R.S.

To comply with the above provisions, the offeror shall complete the schedule of the nature and scope of work by listing, where applicable, the names of the joint contractors and subcontractors to be used after the description of the nature and scope of the work.

ALL JOINT CONTRACTORS OR SUBCONTRACTORS TO BE ENGAGED ON THIS PROJECT

The Offeror certifies that the following is a complete listing of all joint contractors or subcontractors who will be engaged by the Offeror on this Project to perform the nature and scope of work indicated pursuant to Section 103D-302, Hawai‘i Revised Statutes, and understands that failure to comply with this requirement shall be just cause for rejection of the offer.

The Offeror further understands that only those joint contractors or subcontractors listed shall be allowed to perform work on this project, and that all other work necessary shall be performed by the Offeror with his or her own employees. If no joint contractor or subcontractor for any subdivision work is listed, it shall be construed that the work shall be performed by the Offeror with his or her own employees.

All Offerors must be sure that they possess and that the subcontractors listed in the Offer possess all the necessary specialty licenses needed to perform the work for this project. The Offeror shall be solely responsible for assuring that all specialty licenses required to perform the work is covered in his or her offer.

The Offeror shall include the license number of the joint contractors or subcontractors listed below. Failure to provide the correct names and license numbers as registered with the Contractor’s Licensing Board may cause rejection of the offer submitted.

**It is the sole responsibility of the contractor to review the requirements of this Project and determine the appropriate licenses that are required to complete the project.**

LISTING OF ALL JOINT CONTRACTORS OR SUBCONTRACTORS



	Contractor Classification	Name of Joint Contractor or Subcontractor	License Number
C-1	Acoustical and Insulation Contractor		
C-2	Mechanical Insulation Contractor		
C-3	Asphalt Paving and Surfacing Contractor		
C-3a	Asphalt Concrete Patching, Sealing, and Striping Contractor		
C-3b	Play Court Surfacing Contractor		
C-4	Boiler, Hot-Water Heating and Steam Fitting Contractor		
C-5	Cabinet, Millwork, and Carpentry Remodeling and Repairs Contractor		
C-5a	Garage Door and Window Shutters Contractor		
C-5b	Siding Application Contractor		
C-6	Carpentry Framing Contractor		
C-7	Carpet Laying Contractor		
C-9	Cesspool Contractor		
C-10	Scaffolding Contractor		
C-12	Drywall Contractor		
C-13	Electrical Contractor		
C-14	Sign Contractor		
C-15	Electronic Systems Contractor		
C-15a	Fire and Burglar Alarm Contractor		
C-15b	Telecommunications Contractor		
C-16	Elevator Contractor		
C-16a	Conveyor Systems Contractor		
C-17	Excavating, Grading, and Trenching Contractor		
C-19	Asbestos Contractor		
C-20	Fire Protection Contractor		
C-20a	Fire Repressant Systems Contractor		
C-21	Flooring Contractor		

	Contractor Classification	Name of Joint Contractor or Subcontractor	License Number
C-22	Glazing and Tinting Contractor		
C-22a	Glass Tinting Contractor		
C-23	Gunite Contractor		
C-24	Building Moving and Wrecking Contractor		
C-25	Institutional and Commercial Equipment Contractor		
C-27	Landscaping Contractor		
C-27a	Hydro Mulching Contractor		
C-27b	Tree Trimming and Removal Contractor		
C-31	Masonry Contractor		
C-31a	Cement Concrete Contractor		
C-31b	Stone Masonry Contractor		
C-31c	Refractory Contractor		
C-31d	Tuckpointing and Caulking Contractor		
C-31e	Concrete Cutting, Drilling, Sawing, Coring, and Pressure Grouting Contractor		
C-32	Ornamental, Guardrail, and Fencing Contractor		
C-32a	Wood and Vinyl Fencing Contractor		
C-33	Painting and Decorating Contractor		
C-33a	Wall Coverings Contractor		
C-33b	Taping Contractor		
C-33c	Surface Treatment Contractor		
C-34	Soil Stabilization Contractor		
C-35	Pile Driving, Pile and Caisson Drilling, and Foundation Contractor		
C-36	Plastering Contractor		
C-36a	Lathing Contractor		
C-37	Plumbing Contractor		
C-37a	Sewer and Drain Line Contractor		



	Contractor Classification	Name of Joint Contractor or Subcontractor	License Number
C-37b	Irrigation and Lawn Sprinkler Systems Contractor		
C-37c	Vacuum and Air Systems Contractor		
C-37d	Water Chlorination and Sanitation Contractor		
C-37e	Treatment and Pumping Facilities Contractor		
C-37f	Fuel Dispensing Contractor		
C-38	Post Tensioning Contractor		
C-40	Refrigeration Contractor		
C-40a	Prefabricated Refrigerator Panels Contractor		
C-41	Reinforcing Steel Contractor		
C-42	Roofing Contractor		
C-42a	Aluminum and Other Metal Shingles Contractor		
C-42b	Wood Shingles and Wood Shakes Contractor		
C-42c	Concrete and Clay Tile Contractor		
C-42e	Urethane Foam Contractor		
C-42g	Roof coatings Contractor		
C-43	Sewer, Sewage Disposal, Drain, and Pipe Laying Contractor		
C-43a	Reconditioning and Repairing Pipeline Contractor		
C-44	Sheet Metal Contractor		
C-44a	Gutters Contractor		
C-44b	Awnings and Patio Cover Contractor		
C-48	Structural Steel Contractor		
C-48a	Steel Door Contractor		
C-49b	Hot Tub and Pool Contractor		
C-51	Tile Contractor		
C-51a	Cultured Marble Contractor		

	Contractor Classification	Name of Joint Contractor or Subcontractor	License Number
C-51b	Terrazzo Contractor		
C-52	Ventilating and Air Conditioning Contractor		
C-55	Waterproofing Contractor		
C-56	Welding Contractor		
C-57	Well Contractor		
C-57a	Pumps Installation Contractor		
C-57b	Injection Well Contractor		
C-60	Solar Power Systems Contractor		
C-61	Solar Energy Systems Contractor		
C-61a	Solar Hot Water Systems Contractor		
C-61b	Solar Heating and Cooling Systems Contractor		
C-62	Pole and Line Contractor		
C-62a	Pole Contractor		
C-63	High Voltage Electrical Contractor		
C-68	Classified Specialist		
	Licensed Surveyor		
	Licensed Geotechnical Engineer		
	Licensed Structural Engineer		
	Archaeologist		
	Cultural Monitor		
	Licensed Civil Engineer		
	Supervising Control and Data Acquisition (SCADA) Contractor		
*			
*			
*			
*			
*			
*			



\* Contractor to add licenses as required to complete the scope of work. Attach additional sheet as needed. It is understood and agreed that the Department reserves the right to reject any and/or all offers and waive any defects when, in the Department's opinion, such rejection or waiver shall be for the best interest of the Department.

For purpose of evaluating the criterion described in this Invitation For Bids, it is understood and agreed that offers will be compared on the basis of the Total Sum Offer which shall be considered to be the total sum of actual or corrected amounts proposed on each item. The offerors signed Offer shall constitute the Offeror's official offer. The Department reserves the right to designate the contract amount based on selected Offeror's Total Sum Offer depending on the funds available for this Project.

It is also understood and agreed that the work called for under this Project must and shall be completed within **455** consecutive calendar days after written notice has been given to the successful Offeror to commence work. It is also understood and agreed that the quantities given herewith are approximate only and are subject to increase or decrease and that the undersigned will perform all quantities of work, as either increase or decrease, in accordance with the provisions of the specifications.

It is also understood and agreed that the estimated quantities shown for items for which a UNIT PRICE is listed in the Offer are only for the purpose of comparing on a uniform basis offers offered for the work under this contract, and the undersigned agrees that the undersigned is satisfied with and will not dispute said estimated quantities as a means of comparing the offers. It is understood and agreed that the Offeror will make no claims for anticipated profit or loss of profit because of a difference between quantities of the various classes of work done or the materials and equipment actually installed and the said estimated quantities. On UNIT PRICE offers, payment will be made only for the actual number of units incorporated into the finished project at the contract UNIT PRICE.

It is also understood and agreed that if the product of the UNIT PRICE offer and the number of units does not equal the total amount stated by the Offeror in the offer for any item, it will be assumed that the error was made in computing the total amount. For purpose of evaluating the criterion described in this Invitation for Bids, the stated UNIT PRICE alone will be considered as representing the Offeror's intention and the total amount offered on such item shall be considered to be the amount arrived at by multiplying the UNIT PRICE by the number of units.

It is also understood and agreed that the liquidated damages in the amount of **One Thousand Dollars (\$1,000.00)** for each and every calendar day in excess thereof prior to completion of the contract beyond the specified and approved completion date, shall be withheld from payments due to the Contractor, pursuant to the Damages for Delay provision contained in this Invitation for Bids.

It is also understood and agreed that if this offer is accepted, the successful offeror will contract with the Board and said offeror shall furnish the required bonds to the Board within ten (10) days from the date of receiving from the Board the contract prepared and ready for execution.

It is further understood and agreed that the successful offeror will provide all necessary materials, labor, tools, equipment, and other incidental necessary to do all the work and furnish all the materials specified in the contract in the manner and time herein prescribed and according to the requirements of the Department as therein set forth.

The undersigned further understands and agrees that by submitting this Offer, 1) the Offeror is declaring that the Offer is not in violation of Chapter 84, Hawai'i Revised Statutes, and 2) Offeror is certifying that the price(s) submitted was (were) independently arrived at without collusion.

It is also understood and agreed that if this Offer is accepted and the undersigned shall fail to or neglect to contract as aforesaid, the Board may determine that the offeror has abandoned the contract and thereupon forfeiture of the security accompanying the Offer shall operate and the same shall become the property of the Board.

Enclosed herewith is a Bidder's Bond (Bid Security)	( )	for the sum
Surety Bond	( )	
Legal Tender	( )	
Certificate of Deposit	( )	
Share Certificate	( )	
Cashier's Check	( )	
Treasurer's Check	( )	
Teller's Check	( )	
Certified Check	( )	

of \_\_\_\_\_ DOLLARS  
(\$ \_\_\_\_\_) payable to the Department of Water, being not less than the sum required under Sub-Section 2.9 "Bid Security" of the "General Provisions for Construction Contracts of the Department of Water", dated April 25, 2016.



Evidence of the undersigned Offeror having the authority to submit this Offer and to enter a contract is herewith furnished.

Respectfully submitted,

\_\_\_\_\_  
Name of Offeror

\_\_\_\_\_  
Authorized Signature

\_\_\_\_\_  
Print/Type Name & Title of above

\_\_\_\_\_  
Address, Zip Code

\_\_\_\_\_  
Telephone

\_\_\_\_\_  
Contractor's License No.

\_\_\_\_\_  
State of Hawai'i General Excise Tax License No.

\_\_\_\_\_  
Federal Employer Identification No.

Type of Organization: (Please designate)

- Sole Proprietorship     Partnership
- Corporation             Joint Venture
- Other (*please specify*) \_\_\_\_\_

State of Incorporation:         Hawai'i                     Other (*please specify*) \_\_\_\_\_

Name of Performance Bond Surety Co. \_\_\_\_\_

Address \_\_\_\_\_

Authorized to do Business in the State of Hawai'i?  Yes or  No

If corporation, state who will sign contract and signatory's title:

Name	Title
------	-------

_____ Name	_____ Title
---------------	----------------



**If Offeror is a CORPORATION**, the legal name of the corporation shall be set forth above, together with the signature(s) of the Officer(s) authorized to sign contracts on behalf of the corporation and the corporate seal affixed thereto. Please attach to this page evidence of the authority of the Officer (s) to sign on behalf of the Corporation.

**If Offeror is a PARTNERSHIP**, the true name of the firm shall be set forth above, together with the signature(s) of the Partner(s) authorized to sign on behalf of the partnership. Please attach to this page evidence of the authority of the Partner(s) to sign on behalf of the partnership.

**If Offeror is an INDIVIDUAL**, his or her signature shall be placed above.

If signature is by an agent, other than an Officer of a corporation or a member of a partnership, a POWER OF ATTORNEY must be filed with the Department prior to the Offer due date or submitted with the offer; otherwise, the offer may be rejected as irregular and unauthorized.

# IFB Job No. 17-10

## Appendix D-Insurance

### EXHIBIT D INSURANCE REQUIREMENTS *BOARD OF WATER SUPPLY, COUNTY OF KAUAI*

Contractor shall procure and maintain, on primary basis and at its sole expense, at all times during the life of the contract insurance coverages, limits, including endorsements described herein against claims for injuries to persons or damages to property which may arise from or in connection with the performance of the work by the Contractor or the Contractor's agents, representatives, employees or subcontractors. The requirements contained herein, as well as the Department of Water, County of Kaua'i's (hereinafter "DOW") review or acceptance of insurance maintained by the Contractor is not intended to and shall not in any manner limit or qualify the liabilities or obligations assumed by the Contractor.

To the extent applicable, the amounts and types of insurance will conform to the minimum terms, conditions and coverage(s) of Insurance Service Office (ISO) policies, forms, and endorsements.

#### A. General Conditions

**Waiver of Subrogation.** Contractor shall agree by entering into a contract with the Board of Water Supply, County of Kaua'i (hereinafter "Board") to provide a Waiver of Subrogation for the Commercial General Liability, Automobile Liability, and Workers Compensation policies. When required by the insurer, or should a policy condition not permit Contractor to enter into a pre-loss agreement to waive subrogation without an endorsement, the Contractor shall agree to notify the insurer and request the policy be endorsed with a Waiver of Subrogation in favor of the Board. This Waiver of Subrogation requirement shall not apply to any policy, which includes a condition specifically prohibiting such an endorsement, or voids coverage should Contractor enter into such an agreement on a pre-loss basis.

**Additional Insured.** Contractor shall agree to endorse the **BOARD OF WATER SUPPLY, COUNTY OF KAUAI as an Additional Insured** with a CG026 Additional Insured – Designated Person or Organization endorsement, a copy of the applicable policy language, or similar endorsement to all required insurance policy(ies), except for Workers Compensation and Professional Liability.

**Deductibles and Self-Insured Retentions.** Any deductibles or self-insured retentions must be declared to and approved by the DOW. At the option of the DOW, either: the insurer shall reduce or eliminate such deductibles or self-insured retentions as respects the Board; or the Contractor shall provide a financial guarantee (audited financial statement) satisfactory to the Department guaranteeing payment of losses and related investigations, claim administration and defense expenses.

When a self-insured retention (SIR) or deductible exceeds \$50,000, the Department reserves the right, but not the obligation, to review and request a copy of the Contractor's most recent annual report or audited financial statement.

**Contractor's Responsibility.** The Contractor is responsible for paying any portion of any loss not covered because of the operation of any deductible, co-insurance clause or self-insured retention applicable to the insurance required herein. If the Board is damaged by the failure of the Contractor to maintain insurance as required in this paragraph, then the Contractor shall bear all reasonable costs properly attributable to that failure.

**Primary and Non-contributory.** All policies required of the Contractor will be endorsed as primary and any insurance or self-insurance program maintained by the Board shall be non-contributory.

**Certificate of Insurance.** Concurrent with the execution of the contract, Contractor shall provide the Department a certificate of insurance completed by a duly authorized representative of their insurer certifying that the liability coverage(s) is written on an occurrence form. Immediately upon becoming aware that its insurance will be cancelled, non-renewed, or materially changed, Contractor will notify Department by providing written notice.

The Certificate Holder address shall read:

Board of Water Supply, County of Kaua'i  
4398 Pua Loke Street, Līhu'e, HI 96766

Attention: Dustin Moises

Contract No.: [Click here to enter text.](#)

Project Title: Job No. 17-10, WP2020 Project No. KW-07, Rehabilitate Paua Valley Tank No. 1, 0.5 MG Concrete, Kekaha Water System, Kaua'i, Hawai'i

Concurrent with the execution the contract the Contractor shall furnish the Department with original certificates and endorsements effecting required coverage(s). The Department reserves the right to require complete copies of all required insurance policies, including the policy declarations and endorsements affecting the coverage at any time.

Failure to secure and maintain the required insurance shall be considered as a material breach of the contract. Should the Board be forced to expend funds that would have been covered under the specified insurance, Contractor shall reimburse the Board for such funds. In the event the Board determines, in its sole and absolute discretion, that it is necessary to purchase the coverages herein required of the Contractor, and which the Contractor has failed to secure, the Contractor shall reimburse the Board for the expenditure of such funds.

**Right to Revise or Reject.** Department reserves the right, but not the obligation, to review and revise any insurance requirement, not limited to limits, coverages and endorsements based on insurance market conditions affecting the availability or affordability of coverage; or changes in the scope of work or specifications affecting the applicability of coverage. Additionally, the Department reserves the right, but not the



obligation, to review and reject any insurance policies failing to meet the criteria stated herein or any insurer providing coverage due to its poor financial condition or failure to operate legally.

**B. Minimum Insurance Coverage Requirements**

Unless otherwise approved by the Manager and Chief Engineer, the policy or policies of insurance maintained by the Contractor shall provide the following minimum limit(s) and coverage(s) as specified herein and be placed with an insurance carrier authorized to do business in the State of Hawai‘i and rated A-VII by A.M. Best:

**Commercial General Liability.** The Contractor shall procure and maintain Commercial General Liability, with dedicated required limits, as set forth herein, written on occurrence form providing:

- Designated premises basis                      OR                       Per Project basis

The coverages shall include the following:

- Premises Operations
- Independent Contractors
- Products and Completed Operations
- Broad Form Property Damage including completed operations
- Blanket Contractual Liability
- Personal Injury
- Employees named as Additional Insured
- Severability of Interest
- Explosion, Collapse and Underground Property Damage

The minimum limits of liability may be satisfied by providing either:

<p><b>Bodily Injury and Property Damage Combined Single Limit:</b></p> <ul style="list-style-type: none"> <li>• \$2,000,000 per occurrence</li> <li>• \$2,000,000 annual aggregate</li> </ul>	<p><b>OR</b></p>	<p><b>Personal Injury:</b></p> <ul style="list-style-type: none"> <li>• \$1,000,000 per occurrence</li> <li>• \$2,000,000 annual aggregate</li> </ul> <p style="text-align: center;"><b>AND</b></p> <p><b>Products and Completed Operations:</b></p> <ul style="list-style-type: none"> <li>• \$1,000,000 per occurrence</li> <li>• \$2,000,000 annual aggregate</li> </ul>
---	------------------	---

Contractor must provide evidence the Board is an Additional Insured for Products/Completed Operations coverage for both ongoing operations and after

substantial completion of the work. This coverage may be provided by the ISO form CG 2010 (11 85) or an equivalent policy form. Coverage provided by a non-equivalent CGL form shall be specifically endorsed providing both the course of construction and products/completed operations. ISO CG 2010 (04 13) and ISO form CG 2037 (04 13) or an equivalent form is required from the Contractor. The Contractor and subcontractor(s), if any, shall provide evidence to the Department on an annual basis the products/completed operation coverage is in effect for two (2) years after substantial completion of the project.

**Business Automobile Liability.** The Contractor shall procure and maintain Business Automobile Liability written on occurrence form for all Owned, Non-owned, and Hired automobiles. If the Contractor does not own automobiles, Contractor shall agree to maintain coverage for Hired & Non-Owned Auto Liability, which may be satisfied by way of endorsement to the Commercial General Liability policy or separate Business Automobile Liability. Coverage shall be for automobile contractual liability, uninsured and underinsured motorist coverage, basic no-fault, and personal injury protection, as required by Hawaii law with the following limits:

**Bodily Injury**

\$1,000,000 per person  
\$1,000,000 per occurrence

**Property Damage**

\$1,000,000 per accident

**Workers' Compensation and Employer's Liability.** The Contractor shall procure and maintain at all times during the term of the contract the following insurance liability coverage: Workers' Compensation, Temporary Disability Insurance (TDI), and similar insurance that is required by the State of Hawaii or federal laws. Self-insurance is permitted subject to submission of a copy of the appropriate governmental authorization and qualification by the Contractor and subcontractor(s).

The minimum limits of liability to be maintained are as follows:

**Coverage A: State of Hawaii Workers' Compensation Law:**

Statutory Limits

**Coverage B: Employer's Liability:**

Bodily Injury from each accident	\$1,000,000
Bodily Injury from disease	\$1,000,000
Bodily Injury from disease aggregate	\$1,000,000

☒ **Builder's Risk.** The Contractor shall procure and maintain an Inland Marine Builder's Risk policy providing coverage to protect the interests of the Board, Contractor, sub-contractors, architects, and engineers, including property in transit and property on or off-premises, which shall become part of the building, or Project. Coverage shall be written on an **All Risk, Replacement Cost, and Completed Value Form** basis in an amount at least equal to 100% of the projected completed value of the Project as well as subsequent modifications of that sum, unless an agreed amount is otherwise stated between the Department and the Contractor. The policy shall insure all work, labor, and materials furnished by the Contractor and the Contractor's subcontractors against loss occasioned by fire, lightning, windstorm, theft, vandalism, malicious mischief, flood, earthquake, and collapse.

The amount of coverage for the perils of flood and earthquake may be subject to a sub-limit. The sub-limit shall provide coverage of at least 25% of the full replacement cost.

The policy shall also include coverage for debris removal and reasonable compensation for architect's and engineer's services and expenses required as a result of an insured loss. The Contractor shall endorse the policy with a manuscript endorsement eliminating the automatic termination of coverage in the event the building is occupied in whole or in part, or put to its intended use, or partially accepted by the Department. The manuscript endorsement shall amend the automatic termination clause to only terminate coverage if the policy expires, is cancelled, the Board's interest in the building ceases, or the building is accepted or insured by the Board.

The Contractor shall name the Board of Water Supply, County of Kaua'i as a loss payee on the Builder's Risk policy.

☒ **Installation Floater.** The Contractor shall procure and maintain an Installation Floater policy providing coverage to protect the interests of the Board, Contractor, sub-contractor(s), architects, and engineers, including property in transit and property on or off-premises, which shall become part of the project.

Coverage shall be written on an All Risk, Replacement Cost, and Completed Value Form basis in an amount at least equal to 100% of the projected completed value of the Project as well as subsequent modifications of that sum, unless an agreed amount is otherwise stated between the Department and the Contractor. The policy shall insure all work, labor, and materials furnished by the Contractor and the Contractor's subcontractors against loss occasioned by fire, lightning, windstorm, theft, vandalism, malicious mischief, flood, earthquake, and collapse.

The amount of coverage for the perils of flood and earthquake may be subject to a sub-limit. The sub-limit shall provide coverage of at least 25% of the full replacement cost.

The policy shall also include coverage for debris removal and reasonable compensation for architect's and engineer's services and expenses required as a result of an insured loss. The Contractor shall endorse the policy with a manuscript endorsement eliminating

the automatic termination of coverage in the event the building is occupied in whole or in part, or put to its intended use, or partially accepted by the Department. The manuscript endorsement shall amend the automatic termination clause to only terminate coverage if the policy expires, is cancelled, the Board's interest in the building ceases, or the building is accepted or insured by the Board.

The Contractor shall name the Board of Water Supply, County of Kauai as a loss payee on the Installation Floater policy.

**Professional Liability (Errors and Omissions).** The Contractor and its subcontractors shall procure and maintain Professional Liability Insurance (Errors and Omissions Insurance) that covers all such activities under the contract. Such insurance shall have these minimum limits and coverage(s):

\$1,000,000 per occurrence  
\$2,000,000 annual aggregate

For policies written on a "Claims-Made" basis, Contractor warrants the retroactive date equals or precedes the effective date of the contract. In the event the policy is canceled, non-renewed, switched to an Occurrence Form, retroactive date advanced; or any other event triggering the right to purchase a Supplemental Extended Reporting Period (SERP) during the life of the contract, Contractor shall agree to purchase Supplement Extended Reporting Period (SERP) with a minimum reporting period not less than two (2) years. The requirement to purchase a SERP shall not relieve Contractor of the obligation to provide replacement coverage.

**Pollution Legal Liability.** The Contractor shall procure and maintain Pollution Liability or similar Environmental Impairment Liability at a minimum limit not less than:

\$1,000,000 per occurrence  
\$2,000,000 annual aggregate

The policy shall provide coverage for damages against, but not limited to, third-party liability, clean-up, corrective action including assessment, remediation and defense costs.

**Contractor's Pollution Liability.** Contractor shall procure and maintain pollution liability insurance when the Scope of Work involves removal, abatement, encapsulation or other treatment, disposal or remediation of asbestos or other hazardous materials or an exposure to pollutants or impairment of the environment. The policy shall provide coverage for third party liability, clean-up, and corrective action including assessment remediation and defense costs. The policy may be written on either an occurrence form or claims made. The minimum limits of liability shall be:

\$1,000,000 per occurrence  
\$2,000,000 annual aggregate

**Crime Insurance or Commercial Fidelity Bond.** Contractor shall procure and maintain Commercial Crime Insurance or Fidelity Bond providing Employee Dishonesty on a blanket basis covering all of the Contractor’s employees with a minimum amount of insurance at least equal to the amount of the contract. The policy shall be endorsed to cover “Third-Party Liability” including a third-party beneficiary clause in favor of the Board. The policy shall include a minimum twelve (12) month “Discovery Period” when written on a Loss Sustained basis.

**Property.** The Tenant or Lessee, shall agree to maintain property insurance including flood and windstorm written on a replacement cost basis in an amount not less than 100% of the replacement cost of the building(s) and contents, including betterments and improvements made by the Tenant or Lessee, located on the premises. Contractor shall agree to be fully responsible for any deductible or self-insured retention, and to provide this coverage on primary basis.

**Umbrella or Excess Liability.** Contractor may satisfy the minimum liability limits required above under an Umbrella or Excess Liability policy with \$1,000,000 per occurrence and \$2,000,000 aggregate. If Contractor is using its Umbrella or Excess Liability Insurance policy to satisfy the minimum requirements, Contractor shall agree to endorse the Board of Water Supply, County of Kaua‘i as “Additional Insured” on the Umbrella or Excess Liability policy, or shall confirm in writing that its Umbrella or Excess Liability policy “follows form.”

APPENDIX H: Notice of Intent to Propose.

NOTICE OF INTENT

\_\_\_\_\_  
DATE

Manager and Chief Engineer  
Department of Water  
County of Kaua'i  
4398 Pua Loke Street  
Līhu'e, HI 96766

Dear Sir:

In accordance with the Provisions of Section 103D-310, Hawai'i Revised Statutes, you are hereby notified that it is the intent of the undersigned to offer on **JOB NO. 17-10, WP2020 Project No. KW-07 Rehabilitate Pua Valley Tank No. 1, 0.5 MG Concrete, Kekaha Water System, KAUA'I, HAWAI'I**, for which Offers will be due on **October 31, 2019** as required.

I am informed that this Notice of Intent must be received by the Manager no later than 4:30 p.m. Hawai'i Standard Time on **Monday, October 21, 2019**.

VERY TRULY YOURS,

\_\_\_\_\_  
SIGNATURE

\_\_\_\_\_  
PRINT OR TYPE NAME & TITLE OF SIGNER

Hawai'i State Specialty License  
Type and Classification:

\_\_\_\_\_  
NAME OF FIRM

\_\_\_\_\_  
CONTRACTORS LICENSE NO.

Hawai'i State Business  
License No.:

\_\_\_\_\_  
ADDRESS

\_\_\_\_\_  
CITY, STATE & ZIP CODE

\_\_\_\_\_  
TELEPHONE NO.



All prospective offerors must be currently licensed by the Hawai'i Department of Commerce and Consumer Affairs, Division of Professional and Vocational Licensing.

"A" general engineering contractors and "B" general building contractors are reminded that due to the Hawai'i Supreme Court's January 28, 2002 decision in Okada Trucking Co., Ltd. v. Board of Water Supply, et al., 97 Haw. 450(2002), they are prohibited from undertaking any work, solely or as part of a larger project, which would require the general contractor to act as a specialty contractor in any area where the general contractor has no license. Although the "A" and "B" contractor may still submit a Offer on and act as the "prime" contractor on an "A" or "B" project (See, HRS §444-7 for the definitions of an "A" or "B" project.), respectively, and the "A" and "B" contractor obtains "C" specialty contractor's licenses either on its own, or automatically under HAR §16-77-32.). The remaining work must be performed by appropriately licensed entities. It is the sole responsibility of the contractor to review the requirements of this project and determine the appropriate licenses that are required to complete the project.

IFB Job No. 17-10  
Appendix I-NPDES Documents

DAVID Y. IGE  
GOVERNOR OF HAWAII



BRUCE S. ANDERSON, Ph.D.  
DIRECTOR OF HEALTH

STATE OF HAWAII  
DEPARTMENT OF HEALTH  
P. O. BOX 3378  
HONOLULU, HI 96801-3378

In reply, please refer to:  
EMD/CWB

18FF738.FNL.18

December 4, 2018

Mr. Bryan Wienand  
Manager and Chief Engineer  
County of Kauai  
Department of Water  
4398 Pua Loke Street  
Lihue, Hawaii 96766-1600

Attention: Mr. Eric Fujikawa  
Civil Engineer

Dear Mr. Wienand:

**Subject: NOTICE OF GENERAL PERMIT COVERAGE (NGPC)  
National Pollutant Discharge Elimination System (NPDES)  
Job No. 17-10, WP2020 Project No. KW-07, Rehabilitate Paua Valley  
Tank No. 1, 0.5 MG Concrete Kekaha Water System  
Kekaha, Island of Kauai, Hawaii  
File No. HI 18FF738**

This letter is to notify you that the **COUNTY OF KAUAI, DEPARTMENT OF WATER** (hereinafter PERMITTEE) is now covered under the NPDES General Permit authorizing discharges of hydrotesting waters. Coverage under this general permit authorizes you to discharge only hydrotesting water to the receiving State waters discharge point(s) identified in the Notice of Intent (NOI), dated October 24, 2018 (received November 15, 2018), **provided that you comply with Hawaii Administrative Rules (HAR) 11-54; HAR 11-55; HAR 11-55, Appendix A; HAR 11-55, Appendix F; and the information submitted in the NOI.** All other pollutant discharges to State waters are not authorized by this NPDES General Permit. HAR 11-54 and 11-55 are available on the Department of Health (DOH), Clean Water Branch (CWB) website at: <http://health.hawaii.gov/cwb/>.

**This NGPC will take effect on the date of this notice. This NGPC will expire at midnight, July 12, 2022, or when amendments to HAR, Chapter 11-55, Appendix F, are adopted, whichever occurs first. Failure to comply with HAR 11-54; HAR 11-55; HAR 11-55, Appendix A; HAR 11-55, Appendix F; and information provided in the NOI is an enforceable violation and your NGPC may be terminated. If you violate Hawaii Revised Statutes (HRS), Chapter 342D, you may be subject to penalties of up to \$25,000 per violation per day and up to two (2) years in jail.**



**Falsification of information, including providing information in the NOI that does not match what is actually occurring at the project site/facility, may result in criminal penalties for the Permittee and their authorized representative as provided in Clean Water Act, Section 309 and HRS, Section 342D-35.**

As a reminder, this general permit requires the Permittee to:

1. Submit approvals to discharge into the drainage systems identified in the NOI form at least 30 calendar days before the start of hydrotesting activities.
2. Notify DOH of the hydrotesting start date within seven (7) calendar days before the start of hydrotesting activities.
3. Complete and submit the Solid Waste Disclosure Form for Construction Sites to the DOH, Solid and Hazardous Waste Branch, Solid Waste Section as specified on the form at least 30 calendar days before the start of construction activities. The form can be downloaded at: <http://health.hawaii.gov/shwb/files/2013/06/swdiscformnov2008.pdf>.
4. Design, implement, operate, and maintain the project's Hydrotesting BMPs Plan to ensure that the discharge will not cause or contribute to a violation of applicable State water quality standards (WQS). The effluent shall comply with WQS and the effluent limitations required in this general permit prior to any discharge to State waters.
5. Record the date, starting and ending times, and duration (e.g., hours, minutes) of each discharge and report the information in conjunction with the Discharge Monitoring Report (DMR). Refer to the general permit for the DMR due date(s) and any additional monitoring/reporting requirements. The discharge of hydrotesting water shall be monitored by the Permittee as specified below:

Effluent Parameter	Discharge Limitations	Units	Measurement Frequency	Sample Type
Flow	Report	GPM and Gallon	Once/Discharge	Calculated or Estimated
Total Suspended Solids	80.0 <sup>2</sup> 55.0 <sup>3</sup>	mg/l	Once/Discharge	Grab <sup>1</sup>
Turbidity	25.0 <sup>2</sup> 10.0 <sup>3</sup>	NTU	Once/Discharge	Grab <sup>1</sup>
Total Residual Chlorine <sup>4</sup>	19.0	µg/l	Once/Discharge	Grab <sup>1</sup>
pH	5.5-8.0	Standard Units	Once/Discharge	Grab <sup>1, 5</sup>

mg/l Milligrams per liter  
NTU Nephelometric turbidity units  
µg/l Micrograms per liter

- <sup>1</sup> The Permittee shall sample the discharge after dechlorination and/or filtration within the first five (5) minutes of discharge
  - <sup>2</sup> Wet season – November 1 through April 30
  - <sup>3</sup> Dry season – May 1 through October 31
  - <sup>4</sup> The Permittee shall test for chlorine immediately after obtaining a sample and only when effluent from disinfection operations is discharged
  - <sup>5</sup> The Permittee shall test for pH within 15 minutes of obtaining the grab sample
6. Submit a new NOI with filing fee and obtain a new NGPC for any revisions to the information submitted in the NOI (with the exception of changes to contact person information for non-transfer of ownerships and changes to the Hydrotesting BMPs Plan). This NGPC cannot be modified.
  7. Complete and submit the Notice of Cessation (NOC) within 14 calendar days of completion of the discharge activity.

All NGPC compliance submittals, including the DMRs and NOC shall be submitted on the CWB Compliance Submittal Form for Individual NPDES Permits and NGPCs. This form shall be completed on the e-Permitting Portal located at:  
<https://eha-cloud.doh.hawaii.gov/epermit>.

**The Permittee is responsible for obtaining other Federal, State, or local authorizations as required by law.**

Please complete the DOH Customer Satisfaction Survey regarding your request for General Permit coverage. This brief survey is available on the e-Permitting Portal located at: <https://eha-cloud.doh.hawaii.gov/epermit>. Please use the Application Finder button and search for the "Customer Satisfaction Survey."

Mr. Bryan Wienand  
December 4, 2018  
Page 4

18FF738.FNL.18

If you have any questions, please contact the Enforcement Section or Mr. Colin Maruoka of the Engineering Section, CWB, at (808) 586-4309.

Sincerely,



ALEC WONG, P.E., ACTING CHIEF  
Environmental Management Division

CTM:na

c: Mr. Eunjin Kotkovetz, Myounghee Noh & Associates, LLC  
[via e-mail [eunjin@noh-associates.com](mailto:eunjin@noh-associates.com) only]  
Mr. Eric Fujikawa, Kauai DOW  
[via e-mail [efujikawa@kauaiwater.org](mailto:efujikawa@kauaiwater.org) only]

# **IFB Job No. 17-10**

## **Appendix J-Hazardous Materials Survey Report**

**HAZARDOUS MATERIAL SURVEY REPORT  
FOR  
REPAIRS TO KEKAHA 0.5 MG CONCRETE STORAGE TANK  
COUNTY OF KAUAI DEPARTMENT OF WATER  
KEKAHA WATER SYSTEM  
KEKAHA, ISLAND OF KAUAI 96752**

**TMK (4) 1-2-002:039**

**MNA PROJECT 2388\_3**

**DECEMBER 14, 2017**



**Myounghee Noh & Associates**

**Environmental Studies and Consulting Services**

200 Kohola Street, Hilo, Hawaii, USA 96720 • 808.935.8727  
99-1046 Iwaena Street, Suite 210A, Aiea, Hawaii, USA 96701 • 808.484.9214

This report is prepared for:

KAI Hawaii, Inc.  
50 S. Beretania Street, #C-119C  
Honolulu, Hawaii 96813

**HAZARDOUS MATERIAL SURVEY REPORT**  
**FOR**  
**REPAIRS TO KEKAHA 0.5 MG CONCRETE STORAGE TANK**  
**COUNTY OF KAUAI DEPARTMENT OF WATER**  
**KEKAHA WATER SYSTEM**  
**KEKAHA, ISLAND OF KAUAI 96752**

TMK (4) 1-2-002:039

MNA Project 2388\_3

December 14, 2017



Akari Ihara  
Building Inspector  
(HI Cert. HIASB-1014, Exp. 04/20/2018)



Jessica Walsh  
Report Writer



Myounghee Noh, CIH  
Principal

Myounghee Noh & Associates, L.L.C.  
Environmental Studies and Consulting Services  
99-1046 Iwaena Street, Suite 210A, Aiea, HI 96701  
Tel (808) 484-9214  
[www.noh-associates.com](http://www.noh-associates.com)

**TABLE OF CONTENTS**

**EXECUTIVE SUMMARY.....iv**

**1.0 INTRODUCTION..... 1**

**2.0 SAMPLING AND SURVEY METHODS ..... 1**

    2.1 Identifying Homogeneous Materials..... 3

    2.2 Building Material Sampling ..... 3

**3.0 LABORATORY INFORMATION ..... 4**

**4.0 ASBESTOS RESULTS..... 4**

**5.0 LEAD RESULTS..... 6**

**6.0 ARSENIC RESULTS ..... 7**

**7.0 SUSPECT PCB-CONTAINING BULK MATERIAL RESULTS ..... 7**

**8.0 SUMMARY OF SURVEY RESULTS ..... 8**

**9.0 RECOMMENDATIONS FOR RENOVATION AND CONSTRUCTION WORK ..... 9**

    9.1 Asbestos-Containing Materials ..... 9

    9.2 Lead-Containing Paints..... 11

    9.3 Arsenic-Containing Materials ..... 12

    9.4 PCB-Containing Bulk Materials ..... 12

**10.0 LIMITATIONS ..... 14**

**FIGURE**

Figure 1. Vicinity Map..... 2

**TABLES**

Table 1. Summary of Sampling and Results..... 3

Table 2. Asbestos-Containing Material Determination ..... 5

Table 3. Lead-Containing Paint Determination..... 6

Table 4. Bulk PCB Determination..... 7

## **APPENDICES**

- Appendix A Inspector Certifications
- Appendix B Homogeneous Materials Identified and Sample Types Collected
- Appendix C Sample and Hazardous Material Location Drawings
- Appendix D Photographs
- Appendix E Laboratory Analytical Reports

## **CONTRIBUTORS**

Project Manager	Akari Ihara
Certified Inspectors	Akari Ihara, Danny Falanug
Data QC	Kristin Cabanila
Drafter/Illustrator	Kristin Cabanila
Report Writer	Jessica Walsh
Editor/QC	Akari Ihara

## EXECUTIVE SUMMARY

In July 2017, Myounghee Noh & Associates, L.L.C. (MNA), was retained by KAI Hawaii, Inc., to conduct a hazardous material survey at the County of Kauai Department of Water (DOW) Paua Valley 0.5 MG concrete water tank located at Tax Map Key (TMK) (4) 1-2-002:039, Kekaha, Kauai. The survey targeted building materials in and on the 0.5 MG water tank; the second tank on the parcel was a metal water tank and was not included in the survey.

The objective of the survey was to identify the existence (if any), extent, and condition of hazardous materials present in and on the tank, so that the information can be incorporated in the rehabilitation design.

On August 17, 2017, MNA conducted this hazardous material survey and identified a total of 19 suspect building materials. On October 19, 2017, MNA collected additional bulk samples from the black coating on the interior wall of the tank for analysis of PCB and asbestos content, at the request of the State of Hawaii Department of Health Safe Drinking Water Branch. Based on the analysis of 21 asbestos bulk samples, 12 lead paint chip samples, and 12 polychlorinated biphenyls (PCB) bulk samples, MNA provides the following summary:

- No regulated asbestos-containing materials (ACM) were identified during the survey. One material, **beige coating** in poor condition **on concrete floor** contained 0.25% asbestos. This level of asbestos is considered a trace amount. While the less than 1% asbestos is not a regulated material, airborne fibers in unventilated space can be a respiratory hazard.
- Four lead-containing paints (LCP) were identified in the project area:
  - **Light blue paint** in fair condition, **710 milligrams per kilogram (mg/kg)** and **1,200 mg/kg, on exterior concrete roofing system**, approximately 2,000 square feet.
  - **Light green paint** in fair condition, **1,200 mg/kg** and **1,400 mg/kg, on exterior metal handrail and ladder**, approximately 20 linear feet.

Two of the identified LCP were lead-based paint (LBP), exceeding 5,000 mg/kg, as follows:

- **Dark green paint** in fair condition, **41,000 mg/kg** and **55,000 mg/kg, on exterior metal hatch**, approximately 5 square feet.
- **Beige paint** in poor condition, **40,000 mg/kg** and **41,000 mg/kg, on interior concrete floor**, approximately 5,000 square feet.
- No suspect arsenic-containing materials were identified in the project area.
- Three PCB-containing materials were identified in the concrete water tank:
  - **Beige coating** in poor condition, **28.4 mg/kg (total PCB congeners), on interior concrete floor and debris**, approximately 5,000 square feet.
  - **Beige asphaltic base sealant** in fair condition, **10.5 mg/kg (total PCB congeners), on interior concrete joint**, approximately 220 square feet.



- **Black coating** in poor condition, **283 mg/kg (total PCB congeners) based on confirmation sampling, on interior concrete wall**, approximately 4,840 square feet.

No suspected hazardous materials were identified on the tank access road, which is slated for re-paving as part of this project.

Based on the visual survey and sampling and analysis of suspect bulk materials and paints, special hazard control measures are warranted for work involving lead-containing paint (LCP), lead-based paint (LBP), and PCB-containing material. These control measures are briefly described in Section 9 Recommendations for Renovation and Construction Work. General dust and runoff controls are also warranted.

The contractor must verify the location and volumes of potentially hazardous materials and determine the appropriate dust and hazard control measures based on the area and material to be disturbed. Quantities of materials provided in this report are based on visual approximations only during the survey and should not be used for bidding purposes.

## 1.0 INTRODUCTION

Myounghee Noh & Associates, L.L.C. (MNA), under an agreement with KAI Hawaii, Inc., conducted a hazardous material survey for the County of Kauai Department of Water (DOW) Paua Valley 0.5 MG Tank located at Tax Map Key (TMK) (4) 1-2-002:039, Kekaha, Kauai.

MNA's survey was conducted in support of the planned concrete water tank repair and rehabilitation project. The building materials on the DOW 0.5MG Tank were assessed; the second tank on the parcel was a metal tank and was not part of the survey. The survey targeted the following materials:

- Hazardous building materials due to the suspected presence of asbestos, lead, or arsenic.
- Suspect polychlorinated biphenyls (PCB)-containing tank liner material.



Kauai County DOW 0.5MG Tank  
August 2017

## 2.0 SAMPLING AND SURVEY METHODS

During August 17 and October 19, 2017, State of Hawaii-certified building inspectors, Akari Ihara and Danny Falanug, conducted the hazardous material survey. The inspectors performed a visual assessment of the interior and exterior of the tank, identified materials suspected of containing asbestos, lead, arsenic, or PCB, and collected samples of these materials. Inspector certifications are presented in Appendix A.

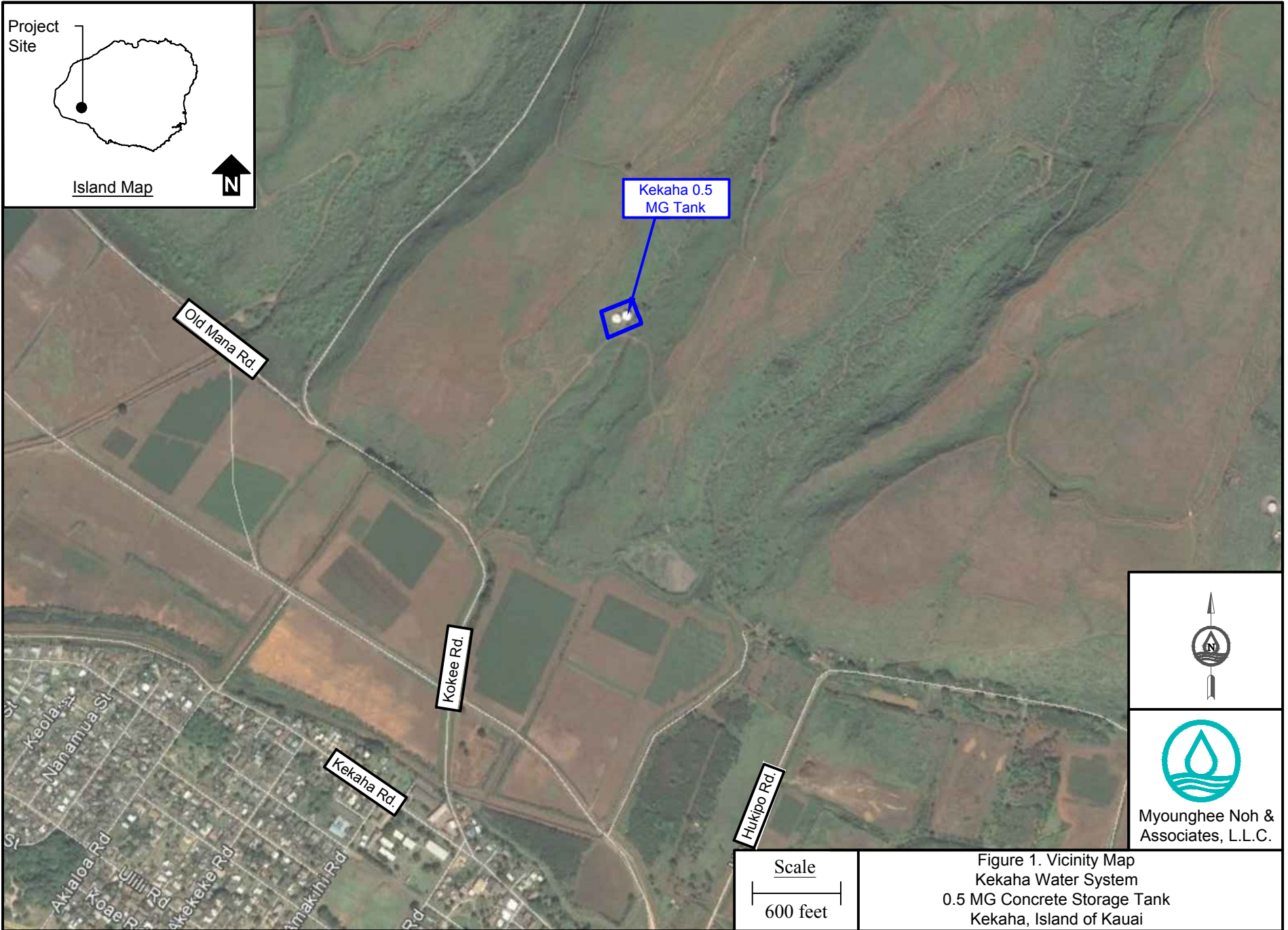


Figure 1. Vicinity Map  
 Kekaha Water System  
 0.5 MG Concrete Storage Tank  
 Kekaha, Island of Kauai

## 2.1 Identifying Homogeneous Materials

The inspectors identified building materials with the same appearance, color, and substrate as homogeneous materials. Interior homogeneous materials are considered unique per building and building floor, while exterior building materials are considered unique per building. Building materials with the same characteristics (appearance, color, and substrate), as an identified homogeneous material, should be considered to possess the same hazard characteristics, unless specifically identified as otherwise in the report. As an example, if dark green paint on metal is found to be lead-based paint (LBP), then all identical dark green paint on metal in the survey area should be treated as LBP. Table 1 provides an overview of sampling and a summary of hazardous materials identified.

**Table 1. Summary of Sampling and Results**

Materials Sampled	Samples Submitted/Inspected	Suspect Material Locations	Identified Hazardous Materials
<b>Paua Valley 0.5 MG Concrete Water Tank</b>			
Asbestos in bulk material or paint	21	Floor, roofing system, sealant joint, vent, walls	1 Material containing trace asbestos*
Lead in paint	10	Floor, handrail, hatch, ladder, roofing system, walls	4 LCP (710 mg/kg – 55,000 mg/kg) including 2 LBP (40,000 mg/kg – 55,000 mg/kg)
Arsenic in bulk material	0	--	None
PCB in bulk material	12	Debris, floor, sealant joint, walls	3 PCB-containing tank liner materials (10.5 mg/kg – 283 mg/kg Total PCB)

\* Trace indicates that one or more asbestos fibers were detected by the point count method. While the less than 1% asbestos is not a regulated material, OSHA considers the trace amount as a health concern.

LBP – Lead-Based Paint,  $\geq 5,000$  mg/kg

mg/kg – milligrams per kilogram (equivalent to parts per million)

LCP – Lead-Containing Paint,  $< 5,000$  mg/kg

PCB – Polychlorinated biphenyls

## 2.2 Building Material Sampling

Bulk and paint samples were collected using a decontaminated chisel, razor, or hammer in a manner that minimized airborne dust. The inspector collected triplicate samples for asbestos and PCB-containing tank liner material and duplicate samples for lead. Additional confirmation sampling was conducted for the tank liner material. No suspected arsenic-containing building materials were identified. Samples were placed in sealable plastic bags, labeled with a unique identification number, and recorded on a chain-of-custody. For each sample, the date, sample appearance, analyte, and sample location were recorded on a field data form. Asbestos and PCB samples were transported under chain-of-custody to LA Testing in South Pasadena, California.

LA Testing utilized its sister company EMSL Analytical, Inc., in Cinnaminson, New Jersey, to analyze the PCB samples. Lead samples were transported under chain-of-custody to Hawaii Analytical Laboratory, LLC, in Honolulu, Hawaii.

### **3.0 LABORATORY INFORMATION**

LA Testing analyzed the asbestos samples by polarized light microscopy using the Environmental Protection Agency (EPA) Method 600/R-93/116. LA Testing, South Pasadena, is certified by:

- National Voluntary Laboratory Accreditation Program (NVLAP), certification 200232-0
- State of Hawaii Department of Health (HDOH), certification L-01-034
- American Industrial Hygienist Association (AIHA) Environmental Lead Laboratory Accreditation Program (ELLAP), certification 102814

Hawaii Analytical Laboratory analyzed the lead samples by flame atomic absorption spectroscopy using the EPA Method 7082m. Hawaii Analytical Laboratory, Honolulu, is certified by:

- NVLAP, certification 200655-0
- HDOH, certification L-14-002
- AIHA ELLAP, certification 101812

EMSL Analytical analyzed the PCB samples by gas chromatography using the EPA Method 3540C/8082A. EMSL Analytical, Cinnaminson, is certified by the New Jersey Environmental Laboratory Accreditation Program (ELAP), certification 03036.

### **4.0 ASBESTOS RESULTS**

Materials determined to contain greater than, or equal to, 1% asbestos are considered regulated asbestos-containing material (ACM) under the National Emission Standards for Hazardous Air Pollutants (NESHAP) as specified in 40 Code of Federal Regulations (CFR) Part 61 Subpart M. The U.S. Occupational Safety and Health Administration (OSHA) Asbestos General Industry and Construction Standards also define ACM as 1% asbestos or more by volume under 29 CFR 1910.1001 and 29 CFR 1926.1101, respectively. However, any measurable levels of asbestos fibers are considered to be a health concern.

Six homogeneous materials suspected of containing asbestos were identified and sampled, generating 18 samples for analysis. However, none of the samples contained 1% or greater asbestos by volume. Therefore, it is concluded that no regulated ACM are present in the area anticipated to be disturbed (Table 2).

One material (HM 7, beige cement material on interior concrete floor) contained less than 1% asbestos, and was therefore subjected to a point count analysis. Laboratory point count analytical results for this material indicated trace amounts of asbestos, less than 0.25% asbestos, and is not classified as ACM. The term “trace” indicates that one or more asbestos fibers were detected by the point count method. While the less than 1% asbestos is not a regulated material, airborne fibers in unventilated space can be a respiratory hazard and health concern.

Due to the <1% results, an additional triplicate confirmation sample was collected for the black coating on the inner concrete wall (HM ID 9). It was verified that the coating material contained no measurable amount of asbestos, but there was insufficient volume of concrete in the sample to verify asbestos level in the concrete wall. This material should be sampled prior to disturbance.

The suspected ACM descriptions and identifiers are provided in Appendix B. Sample location drawings are provided in Appendix C. Photographs of suspected materials are presented in Appendix D. Laboratory analytical reports, chain-of-custody, and field data forms are provided in Appendix E.

**Table 2. Asbestos-Containing Material Determination**

Locations	HM ID	Material Color	Material	Substrate	Result	Condition	Estimated Quantity
Roofing system	2	Lt. blue	Paint/skim coat	Concrete	ND	Fair	3,850 sq. ft.
Roof vent	3	Gray	Cement board	Concrete	ND	Fair	105 ln. ft.
Exterior wall	11	Orange	Paint/skim coat	Concrete	ND	Poor	4,840 sq. ft.
Tank floor	7	Beige	Coating Cement material	Concrete	ND <0.25%*	Poor	3,850 sq. ft.
Tank interior Sealant joint	8	Beige	Coating Texture Tar	Concrete	ND	Fair	220 sq. ft.
Tank interior wall	9	Black	Coating	Concrete	ND	Poor	4,850 sq. ft.
Tank interior wall	9C1	Black	Coating	Concrete	ND	Poor	4,850 sq. ft.

\* Indicates presence of materials containing trace asbestos. “Trace” means that one or more asbestos fibers were detected by the point count method. While the less than 1% asbestos is not a regulated material, OSHA considers the trace amount as a health concern.

Fair – Material is functional for its installed purpose but shows initial signs of deterioration beyond the cosmetic.  
Poor – Material shows significant deterioration and may not be functional for its installed purpose. The binding of the material has decreased integrity as indicated by peeling, cracking, or crumbling of the material.

Abbreviations and Acronyms

HM ID – Homogeneous Material Identifier                      ND – Not Detected  
In. ft. – Linear Feet    sq. ft. – Square Feet

**5.0 LEAD RESULTS**

The U.S. Department of Housing and Urban Development (HUD) and the EPA define paint containing 5,000 milligrams per kilogram (mg/kg), or 0.5% by weight, or more of lead to be LBP. OSHA and the State of Hawaii consider paint containing any measurable concentration of lead to be lead-containing paint (LCP) and a health concern. When lead is detected in a multi-layer sample, it is assumed that all layers represented by the sample contain lead at the same concentration.

Five suspected lead paints were identified and sampled, generating 10 paint chip samples. Four LCP were identified in the survey area, with sample results ranging from 710 mg/kg to 55,000 mg/kg. Two of those LCP were identified as LBP, exceeding 5,000 mg/kg, the threshold for LBP (Table 3).

Suspected LCP descriptions and identifiers are provided in Appendix B. Sample and hazardous material location drawings are in Appendix C. Photographs of suspected LCP are presented in Appendix D. Laboratory analytical reports, chain-of-custody, and field data forms are provided in Appendix E.

**Table 3. Lead-Containing Paint Determination**

Locations	HM ID	Material Color	Material	Substrate	Result (mg/kg)	Condition	Estimated Quantity
Roofing system	1	Lt. blue	Paint	Concrete	LCP 710 - 1,200	Fair	3,850 sq. ft.
Roof hatch	4	Dk. green	Paint	Metal	<b>LBP 41,000 - 55,000</b>	Fair	10 sq. ft.
Exterior handrail, ladder	5	Lt. green	Paint	Metal	LCP 1,200 - 1,400	Fair	90 ln. ft.
Exterior wall	10	Orange	Paint	Concrete	<40	Poor	4,840 sq. ft.
Exterior wall	12	Beige	Paint	Concrete	<40	Poor	2,420 sq. ft.
Interior Floor	6	Beige	Coating	Concrete	<b>LBP 40,000 - 41,000</b>	Poor	3,850 sq. ft.

**Bold values indicate results above the reporting limit.**

Fair – Material is functional for its installed purpose but shows initial signs of deterioration beyond the cosmetic.

Poor – Material shows significant deterioration and may not be functional for its installed purpose. Paint is bubbling or peeling over 20% or more of surface area and no longer protects the substrate.

**Abbreviations and Acronyms**

HM ID – Hazardous Material Identifier	ln. ft. – Linear Feet
LBP – Lead-Based Paint, $\geq 5,000$ mg/kg	mg/kg– milligrams per kilogram or parts per million
LCP – Lead-Containing Paint, $< 5,000$ mg/kg	sq. ft. – Square Feet

**6.0 ARSENIC RESULTS**

The disturbance of arsenic-containing materials is regulated by the OSHA Inorganic Arsenic General Industry Standard under 29 CFR 1910.1018. No suspected arsenic-containing materials were observed; therefore, no samples were collected during this survey.

**7.0 SUSPECT PCB-CONTAINING BULK MATERIAL RESULTS**

The storage and disposal of PCB-containing materials is regulated by the Toxic Substances Control Act (TSCA) PCB Regulations under 40 CFR 761 Subpart D. Three tank lining materials suspected of containing PCB were identified and sampled, generating 12 samples (nine primary and three confirmation) for analysis. All three materials were identified as PCB-containing, with total PCB concentrations ranging from 10.5 mg/kg to 283 mg/kg.

PCB-containing material descriptions and identifiers are provided in Appendix B. Sample and hazardous material location maps are provided in Appendix C. Photographs of suspect materials are provided in Appendix D. Laboratory analytical reports, chains of custody, and field data forms are provided in Appendix E.

**Table 4. Bulk PCB Determination**

Locations	HM ID	Material Color	Material	Substrate	Result (mg/kg)	Estimated Quantity (sq. ft.)
Inside tank floor bottom, debris	13	Beige	Coating	Concrete	Aroclor-1016, 1221, 1232, 1248: ND <b>Aroclor-1242: 2.3</b> <b>Aroclor-1254: 8.1</b> <b>Aroclor-1260: 18</b> Aroclor-1262: ND <u>Aroclor-1268: ND</u> <b>Total PCB: 28.4</b>	3,850
Inside tank sealant joint	14	Beige	Asphaltic base sealant	Concrete	Aroclor-1016, 1221, 1232, 1248: ND <b>Aroclor-1242: 2.4</b> <b>Aroclor-1254: 3.4</b> <b>Aroclor-1260: 4.7</b> Aroclor-1262: ND <u>Aroclor-1268: ND</u> <b>Total PCB: 10.5</b>	220



Locations	HM ID	Material Color	Material	Substrate	Result (mg/kg)	Estimated Quantity (sq. ft.)
Inside tank wall	15	Black	Coating	Concrete	Aroclor-1016, 1221, 1232, 1242, 1248: ND <b>Aroclor-1254: 38</b> <b>Aroclor-1260: 76</b> Aroclor-1262: ND <u>Aroclor-1268: ND</u> <b>Total PCB: 114</b>	4,840
	15C1				Aroclor-1016, 1221, 1232, 1242, 1248: ND <b>Aroclor-1254: 73</b> <b>Aroclor-1260: 210</b> Aroclor-1262: ND <u>Aroclor-1268: ND</u> <b>Total PCB: 283</b>	
	15C2				Aroclor-1016, 1221, 1232, 1242, 1248: ND <b>Aroclor-1254: 51</b> <b>Aroclor-1260: 170</b> Aroclor-1262: ND <u>Aroclor-1268: ND</u> <b>Total PCB: 221</b>	
	15C3				Aroclor-1016, 1221, 1232, 1242, 1248: ND <b>Aroclor-1254: 39</b> <b>Aroclor-1260: 170</b> Aroclor-1262: ND <u>Aroclor-1268: ND</u> <b>Total PCB: 209</b>	

**Bold values indicate results above the reporting limit.**

All three tank liner materials were identified to be in poor condition, indicating that the material shows significant deterioration and may not be functional for its installed purpose.

HMs 15C1, 15C2, and 15C3 are confirmation samples for HM 15, black coating on interior concrete tank walls.

**Abbreviations and Acronyms**

HM ID – Hazardous Material Identifier  
mg/kg – milligrams per kilogram or parts per million  
ND – Not Detected

PCB – Polychlorinated Biphenyls  
sq. ft. – Square Feet

**8.0 SUMMARY OF SURVEY RESULTS**

MNA conducted a hazardous material survey at the County of Kauai DOW Paua Valley 0.5 MG Tank located in Kekaha, Kauai. MNA’s survey was conducted in support of the tank repair and rehabilitation project. The second tank located on the same parcel was not included in the scope of work for this project. No suspected or confirmed hazardous materials were identified on the tank access road that is slated for repaving as part of this project.

Based on the analysis of 21 asbestos samples, 10 lead samples, and 12 PCB coating samples, MNA provides the following summary:

**Summary of Hazardous Material Findings**

	ACM	LCP	LBP	ArCM	PCB
<b>COUNTY OF KAUAI DOW 0.5MG TANK</b>					
Interior	*		☐		☐
Exterior		☐	☐		

☐ indicates presence of hazardous material

\* Indicates presence of materials containing trace asbestos. “Trace” means that one or more asbestos fibers were detected by the point count method. While the less than 1% asbestos is not a regulated material, OSHA considers the trace amount as a health concern.

ACM – Asbestos-Containing Material

LCP – Lead-Containing Paint, <5,000 mg/kg

ArCM – Arsenic-Containing Material

PCB – Polychlorinated Biphenyls

LBP – Lead-Based Paint, ≥5,000 mg/kg

**9.0 RECOMMENDATIONS FOR RENOVATION AND CONSTRUCTION WORK**

It is required that properly trained employees perform construction work and renovation that disturbs hazardous materials, in a manner protective of the site workers, facility users, and the environment. The following recommendations address OSHA and other applicable federal requirements. These recommendations provide guidance for the management of hazardous building materials and control of occupational and environmental hazards associated with operations, maintenance, renovation, and demolition. These recommendations are based on information gathered during the hazardous materials survey. These recommendations are not intended to constitute a formal work plan but are intended to provide a starting point for the development of a work plan or procedure.

**9.1 Asbestos-Containing Materials**

Employees involved in renovation or demolition activities that disturb materials containing trace amounts of asbestos must conduct work in accordance with 29 CFR 1926.1101, the OSHA Asbestos Construction Standard. Work practices that would trigger these requirements include, but are not limited to, repair, maintenance, or renovation of structures containing asbestos, as well as removal or encapsulation of materials containing asbestos. For each project, the contractor must determine the appropriate safety measures based on the area to be disturbed, the type, volume, and condition of materials containing trace amounts of asbestos. Applicable work practice guidelines involving the disturbance of materials containing trace amounts of asbestos are summarized, but are not limited to:

- Employees must utilize appropriate engineering controls and personal protective equipment (PPE). This PPE includes disposable coveralls, gloves, eye protection, steel-

toed boots, a hard hat, and a National Institute for Occupational Safety and Health (NIOSH)-approved appropriate respirator.

- Employers must provide and require the use of appropriate PPE for any employee exposed to airborne concentrations of asbestos that exceed OSHA regulatory limits, or for which a required negative exposure assessment is not produced (29 CFR 1926.1101[i][1]).
- Employees must utilize respiratory protection until the initial exposure monitoring assessment documents safe working levels of airborne asbestos (29 CFR 1926.1101[f] and [h]). Additional periodic exposure monitoring may be required.
- An initial exposure monitoring assessment should be carried out when workers are disturbing ACM or materials containing trace amounts of asbestos to ensure that they are not exposed to airborne asbestos concentrations greater than the Permissible Exposure Limit (PEL) of 0.1 fibers per cubic centimeter (f/cc) of air as an 8-hour time-weighted average (TWA), and the Excursion Limit of 1.0 f/cc over a 30 minute sampling period.
- The work site must be maintained as a controlled regulated area and supervised by a competent person.
- Employees must implement stringent dust control procedures to prevent asbestos in any airborne dust.
- Employees must clean the work area thoroughly using wet methods and a high-efficiency particulate air (HEPA) vacuum. Dry sweeping or air blowing of asbestos debris and dust must be avoided.
- Waste and dust containing ACM or materials containing trace amounts of asbestos must be collected separately from other construction debris. Employees should conduct prompt clean up and disposal of asbestos wastes and debris in leak-tight containers.
- Asbestos-containing waste must be packaged, labeled, stored, and disposed of in accordance with applicable regulations.
- Visually inspect the work area to ensure that all asbestos-containing debris and dust has been properly removed.
- Conduct clearance in accordance with contract specifications.

## 9.2 Lead-Containing Paints

Employees involved in renovation or demolition activities that disturb LCP or LBP must conduct work in accordance with 29 CFR 1926.62 OSHA Lead Construction Standard. Work practices that would trigger these requirements include, but are not limited to, sanding, blasting, welding, cutting, or scraping. For each project, the contractor must determine the appropriate safety measures based on the area to be disturbed, the lead concentration, and the paint condition. Applicable work practice guidelines involving the disturbance of lead paints are summarized, but are not limited to:

- Employees must utilize appropriate engineering controls and personal PPE. The PPE includes disposable coveralls, gloves, eye protection, steel-toed boots, a hard hat, and a NIOSH-approved appropriate respirator.
- Employees must utilize respiratory protection until the initial air monitoring assessment documents safe working levels of airborne lead (29 CFR 1926.62[d][1] and [2][i][A]).
- An exposure assessment should be carried out when employees are disturbing LCP or LBP to ensure that they are not exposed to airborne lead concentrations greater than the PEL of 50 micrograms per cubic meter ( $\mu\text{g}/\text{m}^3$ ) averaged over an 8-hour period. Additional periodic exposure monitoring may be required if the Action Level,  $30 \mu\text{g}/\text{m}^3$ , averaged over an 8-hour period is exceeded.
- Employees must implement stringent dust control procedures to prevent lead in any airborne dust.
- Employees must clean the work area thoroughly using wet methods and a HEPA vacuum. Dry sweeping or air blowing of lead debris and dust must be avoided.
- Lead-containing debris must be segregated from other wastes, collected, and containerized. Wastes must be characterized per State of Hawaii requirements, including a determination of the waste as hazardous or non-hazardous. Lead-containing waste must be handled and disposed of in accordance with applicable requirements.
- Visually inspect and verify the work area to ensure all lead-containing debris and dust has been properly removed and the project site is free of lead hazard.
- Conduct clearance in accordance with contract specifications.

### 9.3 Arsenic-Containing Materials

No arsenic-containing materials were identified in the targeted areas during this survey. Therefore, no special arsenic control measures are provided.

### 9.4 PCB-Containing Bulk Materials

PCBs were detected from the concrete surface of the inside water tank, especially, from floor debris, sealant joint, and coating materials in the range of 2.4 mg/kg and 210 mg/kg. Based on the analytical findings, removal of PCB-containing loose and flaky materials is warranted. The TSCA (40 CFR Part 761), Subpart G – PCB Spill Cleanup Policy, regulates the cleanup and disposal of PCB contamination. This policy establishes criteria that EPA will use to determine the adequacy of the cleanup of spills resulting from the release of materials containing PCBs at concentrations of 50 ppm or greater. The EPA established three cleanup standards based on the site use as follows:

- a) High Occupancy (most stringent clean up level)
- b) Low Occupancy
- c) Industrial Area

These cleanup standards, however, exclude certain spill situations from its scope, such as spills directly into surface waters, **drinking water**, sewers, grazing lands, and vegetable gardens. The PCB concern at the Paua Valley Water Reservoir may fall into category (d) excluded spills, (iii) **Spills that result in the direct contamination of any private or public drinking water sources or distribution systems** under 40 CFR 761.120.

The general requirements under 40 CFR 761.125(a) do apply to the excluded spills. In addition, the excluded situations require practicable, immediate actions to contain the area of contamination. While these situations may not always require more stringent cleanup measures, the EPA is excluding these scenarios because they will always involve significant factors that may not be adequately addressed by cleanup standards based upon typical spill characteristics. Thus, the responsible party shall notify the EPA Regional 9 office and obtain guidance for appropriate cleanup measures in the shortest possible time after discovery, but in no case later than 24 hours after discovery [40 CFR 761.125 (a)(i)].

Since the cleanup measures and levels are not available from the EPA at the time of this reporting, it is recommended to set up the most stringent cleanup goal regulated from TSCA which is the

goal classified as “High Occupancy Areas.” Once EPA’s directions and guidance are available, the clean-up goal and measures shall be implemented.

High occupancy area is generally defined as any area where PCB remediation waste has been disposed of onsite (including but not limited to any building, any floor/wall of the building, any enclosed space within the building), and where annual occupancy for any individual not wearing dermal and respiratory protection is 840 hours or more for non-porous surfaces and 335 hours or more for bulk PCB remediation waste. Examples include residence, school, day care center, sleeping quarters, a single or multiple occupancy 40 hours-per-week work station, a school classroom, a cafeteria in an industrial facility, a control room, and a work station at an assembly line. There are two options to meet the cleanup goal for “High Occupancy Areas” as follows:

- Option 1: clean up the impacted material to be less than or equal to 1 ppm ( $\leq 1$  ppm) in porous surface without further condition
- Option 2: clean up the impacted material between 1 and 10 ppm ( $>1$  to  $\leq 10$  ppm) if site covered with appropriate cap (encapsulation) and institutional control implemented (deed restriction)

Regardless of which option may be selected, the PCB level in the water after the water tank remediation must meet the EPA National Primary Drinking Water Regulations.

Prior to any PCB remediation/cleanup, all PCB work plans must be reviewed and approved by EPA Region 9. The PCB-containing material or PCB waste including demolished debris shall be tested for PCB and disposed of in accordance with TSCA. If PCB concentration of the waste is below the 50 mg/kg, the material may be eligible for disposal at a local landfill as non-TSCA regulated waste. If the results exceed 50 mg/kg, the waste and debris would be classified as TSCA regulated waste which must be disposed of at a permitted hazardous waste landfill or an approved PCB disposal facility, which are currently not available in the State of Hawaii.

Trained workers are required to remove PCB-containing material or waste, and the work must be performed in accordance with OSHA and EPA requirements. Engineering controls and personal protective equipment should be utilized to prevent PCB release or exposure. Applicable work practice guidelines involving PCB-containing materials or waste are summarized, but are not limited to:

- The Contractor shall prepare a Health and Safety Plan (HASP) for PCB remediation/removal work. The HASP shall include accident and emergency response, proper worker protection regarding machinery to be employed during project activities, worker protection from PCB exposure, and required PPE.
- Employees must utilize appropriate PPE. The PPE may include disposable coveralls, gloves, eye protection, steel-toed safety boots, a hard hat, and a NIOSH-approved appropriate respirator.
- All work involving PCB should be performed by properly trained and equipped personnel.
- Establish PCB controlled areas for removal or spill cleanup to prevent unauthorized entry of personnel. Maintain a log of employees working in PCB controlled areas.
- All PCB waste should be stored and disposed of in compliance with TSCA regulations, and all records involving PCB should be properly maintained.

## **10.0 LIMITATIONS**

Industry standard effort was made to identify suspected hazardous building materials during the survey at the project area. However, this does not imply a guarantee that all suspected building materials and hazardous materials were identified by this assessment because certain building materials and/or surfaces may be hidden by walls, flooring, partitions, or other building components. If any previously unforeseen suspected materials become uncovered, additional survey may be required prior to the planned tank repair and rehabilitation project.

Material quantities provided in this report are based on visual approximations taken at the time of the survey only and should not be used for bidding purpose. It is the Contractor's responsibility to determine the material quantities and volume of waste prior to bidding.

## **APPENDIX A**

### **INSPECTOR CERTIFICATIONS**

**Akari Ihara**

**Danny Falanug**





# State of Hawai'i Asbestos Certification

## Training Course Exp. Dates

W	n/a	MP	n/a
CS	n/a	PD	n/a
INS	10/10/18	PM	09/21/18

**Ihara**  
Akari R.  
Myounghee Noh & Associates, L L C

**HIASB-1014**  
State Exp. Date **04/20/2018**

W= Worker  
CS= Cont /Sup  
INS= Inspector  
PD= Project Designer  
MP= Mgmt. Planner  
PM= Project Monitor

# State of Hawai'i Lead Based Paint Activities Certification

## Expiration Dates:

Inspector	n/a
Supervisor	n/a
Risk Assessor	09/17/2019
Project Designer	n/a
Worker	n/a

**Ihara**

**Akari**

Certification # PB-0056





# State of Hawai'i Asbestos Certification

## Training Course Exp. Dates

W	n/a	MP	n/a
CS	n/a	PD	n/a
INS	05/18/18	PM	05/19/18

W= Worker  
 CS= Cont./Sup.  
 INS= Inspector  
 PD= Project Designer  
 MP= Mgmt Planner  
 PM= Project Monitor

**Falanug  
Danny**

Myounghee Noh & Associates, L.L.C.

**HIASB-3526**

**State Exp. Date 05/25/2018**

# State of Hawai'i Lead Based Paint Activities Certification

## Expiration Dates:

Inspector-	08/12/2019
Supervisor-	n/a
Risk Assessor-	n/a
Project Designer-	n/a
Worker-	n/a

**Falanug  
Danny**

**Certification # PB-0661**



## **APPENDIX B**

### **HOMOGENEOUS MATERIALS IDENTIFIED AND SAMPLE TYPES COLLECTED**

**Homogeneous Materials Identified and Sample Types Collected**

HM ID	Floor	Rooms	Locations	Material Color	Material	Substrate	Asb	Pb	PCB	Result
1	R	Exterior	Roofing system	Lt. blue	Paint	Concrete		X		LCP 710 - 1,200 mg/kg
2	R	Exterior	Roofing system	Lt. blue	Paint/skim coat	Concrete	X			ND
3	R	Exterior	Vent	Gray	Cement board	Concrete	X			ND
4	R	Exterior	Hatch	Dk. green	Paint	Metal		X		LBP 41,000 - 55,000 mg/kg
5	R	Exterior	Handrail, ladder	Lt. green	Paint	Metal		X		LCP 1,200 - 1,400 mg/kg
6	1	Interior	Floor	Beige	Coating	Concrete		X		LBP 40,000 - 41,000 mg/kg
7	1	Interior	Floor	Beige	Coating Cement material	Concrete	X			ND <0.25%* Chrysotile
8	1	Interior	Sealant joint	Beige	Coating Texture Tar	Concrete	X			ND
9	1	Interior	Walls	Black	Coating	Concrete	X			ND
10	1	Exterior	Walls	Orange	Paint	Concrete		X		<40 mg/kg
11	1	Exterior	Walls	Orange	Paint/skim coat	Concrete	X			ND
12	1	Exterior	Walls	Beige	Paint	Concrete		X		<40 mg/kg

**Homogeneous Materials Identified and Sample Types Collected**

HM ID	Floor	Rooms	Locations	Material Color	Material	Substrate	Asb	Pb	PCB	Result
13	1	Interior	Floor, debris	Beige	Coating	Concrete			X	Aroclor-1016, 1221, 1232, 1248: ND <b>Aroclor-1242: 2.3</b> <b>Aroclor-1254: 8.1</b> <b>Aroclor-1260: 18</b> Aroclor-1262: ND Aroclor-1268: ND <b>Total PCB: 28.4</b>
14	1	Interior	Sealant joint	Beige	Asphaltic base sealant	Concrete			X	Aroclor-1016, 1221, 1232, 1248: ND <b>Aroclor-1242: 2.4</b> <b>Aroclor-1254: 3.4</b> <b>Aroclor-1260: 4.7</b> Aroclor-1262: ND Aroclor-1268: ND <b>Total PCB: 10.5</b>
15	1	Interior	Walls	Black	Coating	Concrete			X	Aroclor-1016, 1221, 1232, 1242, 1248: ND <b>Aroclor-1254: 38</b> <b>Aroclor-1260: 76</b> Aroclor-1262: ND Aroclor-1268: ND <b>Total PCB: 114</b>
15C1	1	Interior	Walls	Black	Coating	Concrete			X	Aroclor-1016, 1221, 1232, 1242, 1248: ND <b>Aroclor-1254: 73</b> <b>Aroclor-1260: 210</b> Aroclor-1262: ND Aroclor-1268: ND <b>Total PCB: 283</b>

### Homogeneous Materials Identified and Sample Types Collected

HM ID	Floor	Rooms	Locations	Material Color	Material	Substrate	Asb	Pb	PCB	Result
15C2	1	Interior	Walls	Black	Coating	Concrete			X	Aroclor-1016, 1221, 1232, 1242, 1248: ND <b>Aroclor-1254: 51</b> <b>Aroclor-1260: 170</b> Aroclor-1262: ND Aroclor-1268: ND <b>Total PCB: 221</b>
15C3	1	Interior	Walls	Black	Coating	Concrete			X	Aroclor-1016, 1221, 1232, 1242, 1248: ND <b>Aroclor-1254: 39</b> <b>Aroclor-1260: 170</b> Aroclor-1262: ND Aroclor-1268: ND <b>Total PCB: 209</b>
9C1	1	Interior	Walls	Black	Coating	Concrete	X			ND

**Bold values indicate results above the reporting limit.**

\* Indicates that one or more asbestos fibers were detected by the point count method. While the less than 1% asbestos is not a regulated material, OSHA considers the trace amount as a health concern.

HM 9C1 is a confirmation sample for HM 9.

HM 15C1, 15C2, and 15C3 are confirmation samples for HM 15.

Abbreviations and Acronyms

Asb - Asbestos

HM ID - Homogeneous Material Identifier

LBP - Lead-Based Paint ≥5,000 mg/kg

LCP - Lead-Containing Paint <5,000 mg/kg

mg/kg - milligrams per kilogram, equivalent to parts per million

ND - Not Detected

Pb - Lead

PCB - Polychlorinated Biphenyls

## APPENDIX C

### SAMPLE AND HAZARDOUS MATERIAL LOCATION DRAWINGS

<b>List of Drawings</b>	
Asbestos and Lead Sample and Hazardous Material Locations Tank Interior	C-1 – C-3
Asbestos and Lead Sample and Hazardous Material Locations Tank Exterior	C-4 – C-5

HM ID	Locations	Material	Color	Substrate	Results
7	Floor	Coating Cement Material	Beige	Concrete	Trace <0.25%*

2388-A7A: ND  
 2388-A7B: ND  
 2388-A7C: ND  
 HM ID: 9C1 (Black coating on concrete wall)

2388-A5A: ND  
 2388-A5B: ND  
 2388-A5C: ND  
 HM ID: 9 (Black coating on concrete wall)

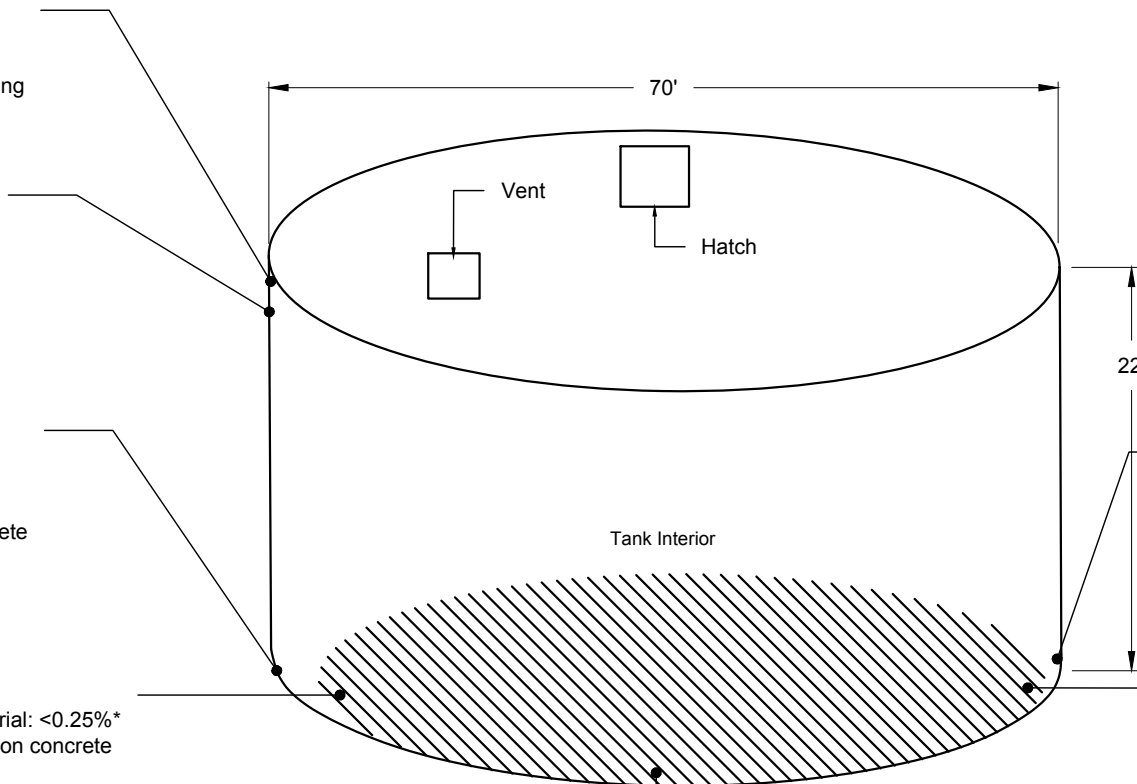
2388-A4A-Coating: ND  
 2388-A4A-Texture: ND  
 2388-A4A-Tar: ND  
 HM ID: 8 (Beige coating, texture, and tar on concrete sealant joint)

2388-A3A-Coating: ND  
 2388-A3A-Cement material: <0.25%\*  
 HM ID: 7 (Beige coating on concrete floor)

2388-A3B-Coating: ND  
 2388-A3A-Cement material: <0.25%\*  
 HM ID: 7 (Beige coating on concrete floor)

2388-A4B-Coating: ND  
 2388-A4B-Texture: ND  
 2388-A4B-Tar: ND  
 2388-A4C: ND  
 HM ID: 8 (Beige coating, texture, and tar on concrete sealant joint)

2388-A3C: ND  
 HM ID: 7 (Beige coating on concrete floor)



Myounghee Noh & Associates, L.L.C.

Sheet Number  
C - 1

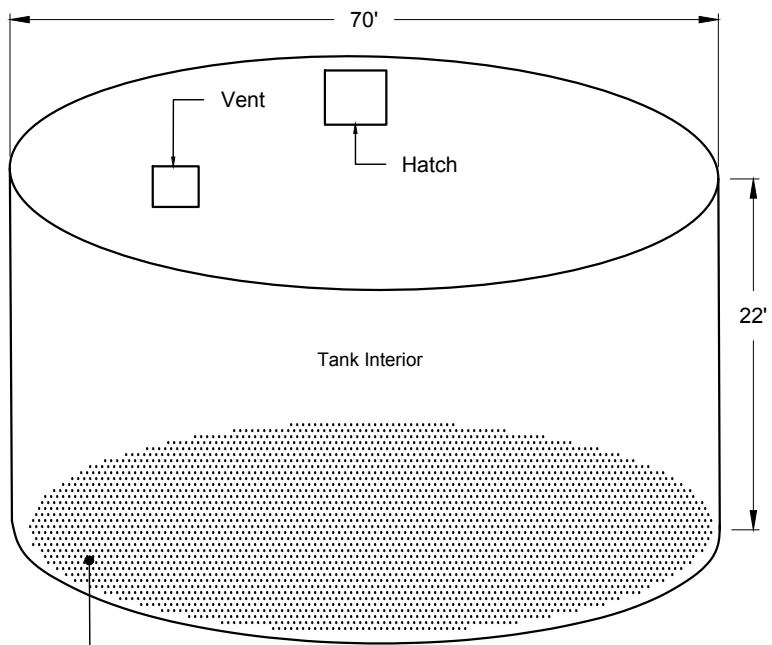
Asbestos Sample and Hazardous Material Locations  
 Kauai Department of Water Repair of Kekaha  
 0.6 MG Concrete Storage Tank Interior

Legend and Notes  
 Visual Extent of Trace Asbestos

All asbestos found to be chrysotile.  
 \* - Indicates that one or more asbestos fibers were detected by the point count method. While the less than 1% asbestos is not a regulated material, OSHA considers the trace amount as a health concern.  
 HM ID - Homogeneous Material Identifier  
 ND - None Detected



HM ID	Locations	Color	Material	Substrate	Results (mg/kg)
6	Floor	Beige	Coating	Concrete	<b>LBP 40,000 - 41,000</b>



**2388-P4A: LBP 41,000 mg/kg**  
**2388-P4B: LBP 40,000 mg/kg**  
**HM ID: 6 (Beige coating on concrete floor)**



Myounghee Noh & Associates, L.L.C.

Legend and Notes

**Visual Extent of Lead-Based Paint**

**Bold values indicate results above the detection limit.**

HM ID - Hazardous Material Identifier

LCP - Lead-Containing Paint < 5,000 mg/kg

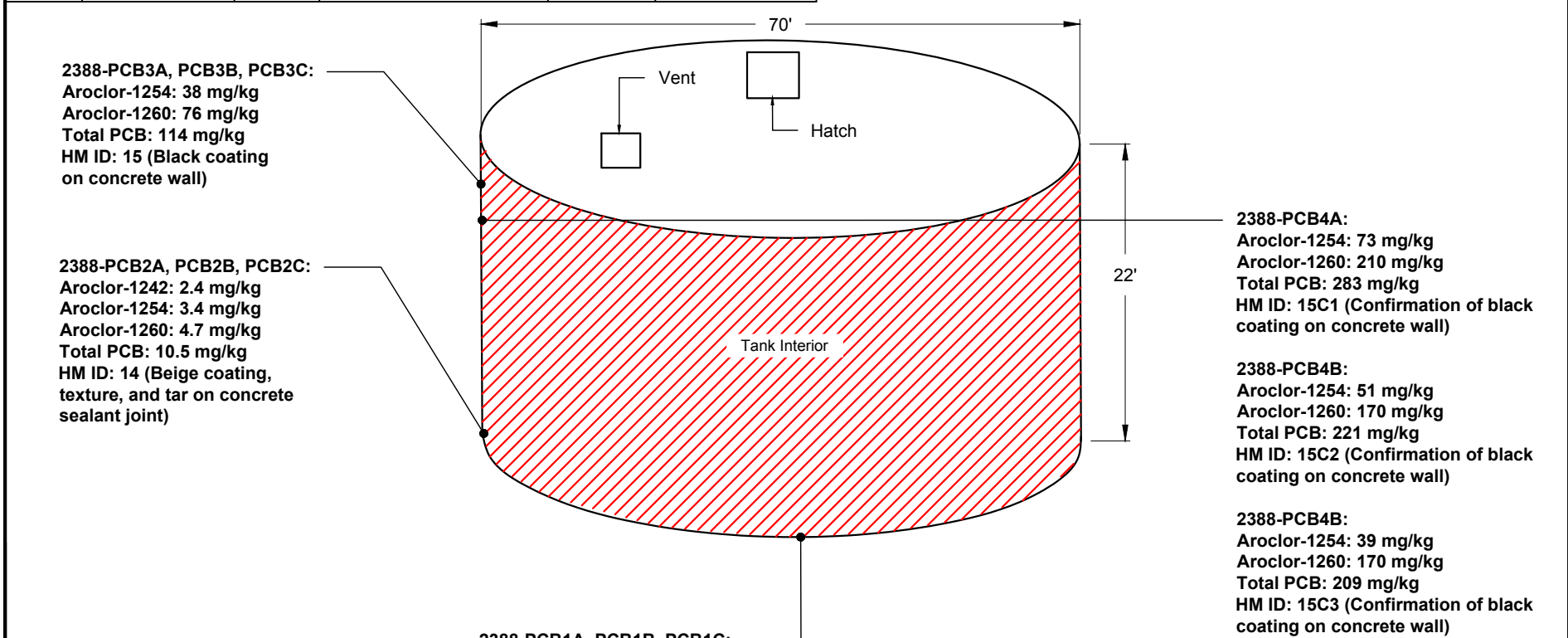
mg/kg - milligrams per kilogram (equivalent to ppm- parts per million)

Lead Sample and Hazardous  
Material Locations  
Kauai Department of Water Repair of Kekaha  
0.6 MG Concrete Storage Tank Interior

Sheet Number

C - 2

HM ID	Locations	Color	Material	Substrate	Results (mg/kg)
13	Floor, debris	Beige	Coating	Concrete	<b>Total PCB: 28.4</b>
14	Sealant joint	Beige	Coating, texture, and tar	Concrete	<b>Total PCB: 10.5</b>
15	Wall	Black	Coating	Concrete	<b>Total PCB: 114</b>
15C1	Wall	Black	Coating	Concrete	<b>Total PCB: 283</b>
15C2	Wall	Black	Coating	Concrete	<b>Total PCB: 221</b>
15C3	Wall	Black	Coating	Concrete	<b>Total PCB: 209</b>



Legend and Notes

Visual Extent of PCB-Containing Material

**Bold values indicate results above the detection limit.**

ND - None Detected

PCB - Polychlorinated Biphenyls

mg/kg - milligrams per kilogram (equivalent to ppm- parts per million)

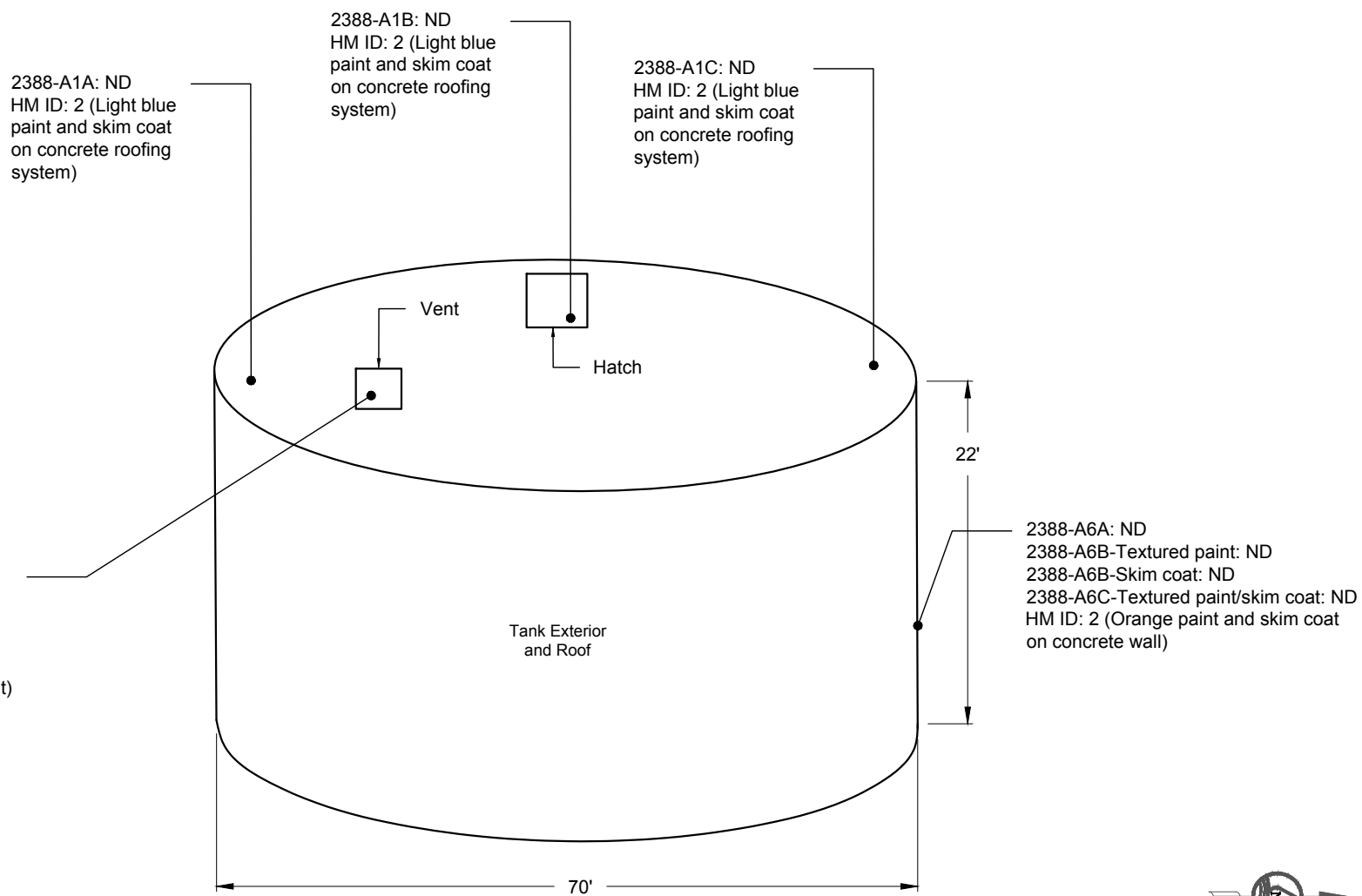
**2388-PCB1A, PCB1B, PCB1C:**  
 Aroclor-1242: 2.3 mg/kg  
 Aroclor-1254: 8.1 mg/kg  
 Aroclor-1260: 18 mg/kg  
 Total PCB: 28.4 mg/kg  
 HM ID: 13 (Beige coating on concrete floor and debris)



Myounghee Noh & Associates, L.L.C.

PCB Sample and Hazardous Material Locations  
 Kauai Department of Water Repair of Kekaha  
 0.6 MG Concrete Storage Tank Interior

Sheet Number  
 C - 3



Myounghee Noh & Associates, L.L.C.

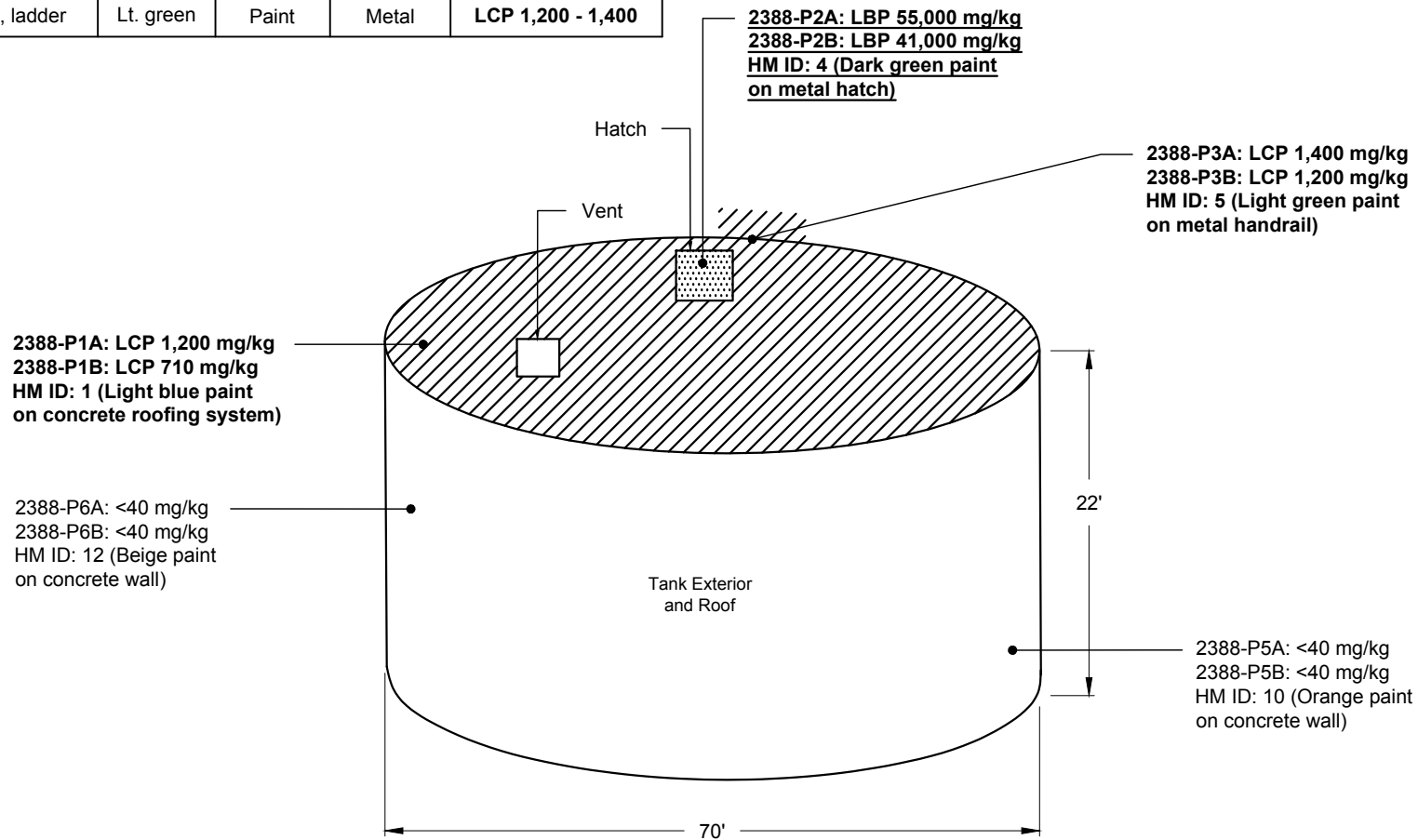
Legend and Notes

HM ID - Homogeneous Material Identifier  
ND - None Detected


Asbestos Sample Locations  
Kauai Department of Water Repair of Kekaha  
0.6 MG Concrete Storage Tank  
Exterior and Roof


Sheet Number  
C - 4

HM ID	Locations	Color	Material	Substrate	Results (mg/kg)
1	Roofing system	Lt. blue	Paint	Concrete	<b>LCP 710 - 1,200</b>
4	Hatch	Dk. green	Paint	Metal	<b>LBP 41,000 - 55,000</b>
5	Handrail, ladder	Lt. green	Paint	Metal	<b>LCP 1,200 - 1,400</b>



Legend and Notes

 **Visual Extent of Lead-Based Paint**

 **Visual Extent of Lead-Containing Paint**

**Bold values indicate results above the detection limit.**

HM ID - Hazardous Material Identifier

LBP - Lead-Based Paint  $\geq 5,000$  mg/kg

LCP - Lead-Containing Paint < 5,000 mg/kg

mg/kg - milligrams per kilogram (equivalent to ppm- parts per million)



Myounghee Noh & Associates, L.L.C.

Lead Sample and Hazardous Material Locations  
 Kauai Department of Water Repair of Kekaha 0.6  
 MG Concrete Storage Tank Exterior and Roof

Sheet Number

C - 5

## **APPENDIX D**

## **PHOTOGRAPHS**



HM ID: 1  
0.5 MG Tank  
Roof

Exterior  
Light blue paint on concrete roofing system.

LCP  
2388-P1A: 1,200 mg/kg  
2388-P1B: 710 mg/kg



HM ID: 2  
0.5 MG Tank  
Roof

Exterior  
Light blue paint and skim coat on concrete roofing system.

Non-ACM  
2388-A1A: ND  
2388-A1B: ND  
2388-A1C: ND



HM ID: 3  
0.5 MG Tank  
Roof

Exterior  
Gray cement board on concrete vent.

Non-ACM  
2388-A2A: ND  
2388-A2B: ND  
2388-A2C: ND



HM ID: 4  
0.5 MG Tank  
Roof

Exterior  
Dark green paint on metal hatch.

**LBP**  
**2388-P2A: 55,000 mg/kg**  
**2388-P2B: 41,000 mg/kg**



HM ID: 5  
0.5 MG Tank  
Roof

Exterior  
Light green paint on metal handrail.

**LCP**  
**2388-P3A: 1,400 mg/kg**  
**2388-P3B: 2,100 mg/kg**



HM ID: 6  
0.5 MG Tank  
Floor 1

Interior  
Beige coating on concrete floor.

**LBP**  
**2388-P4A: 41,000 mg/kg**  
**2388-P4B: 40,000 mg/kg**



HM ID: 7  
0.5 MG Tank  
Floor 1

Interior  
Beige coating on concrete floor.

Trace ACM\*

2388-A3A-Coating: ND  
2388-A3A-Cementitious Material: <0.25% Chrysotile  
2388-A3B-Coating: ND  
2388-A3B-Cementitious Material: <0.25% Chrysotile  
2388-A3C: ND



HM ID: 8  
0.5 MG Tank  
Floor 1

Interior  
Beige asphaltic base sealant on concrete sealant joint.

Non-ACM

2388-A4A- Coating: ND  
2388-A4A-Texture: ND  
2388-A4A-Tar: ND  
2388-A4B-Coating: ND  
2388-A4B-Texture: ND  
2388-A4B-Tar: ND  
2388-A4C-Coating: ND  
2388-A4C-Texture: ND  
2388-A4C-Tar: ND



HM ID: 9  
0.5 MG Tank  
Floor 1

Interior  
Black coating on concrete wall.

Non-ACM

2388-A5A: ND  
2388-A5B: ND  
2388-A5C: ND





HM ID: 10  
0.5 MG Tank  
Floor 1

Exterior  
Orange paint on concrete wall.

Non-LCP  
2388-P5A: <40 mg/kg  
2388-P5B: <40 mg/kg



HM ID: 11  
0.5 MG Tank  
Floor 1

Exterior  
Orange paint and skim coat on concrete wall.

Non-ACM  
2388-A6A: ND  
2388-A6B-Texture Paint: ND  
2388-A6B-Skim Coat: ND  
2388-A6C-Texture Paint/Skim Coat: ND



HM ID: 12  
0.5 MG Tank  
Floor 1

Exterior  
Beige paint on concrete wall.

Non-LCP  
2388-P6A: <40 mg/kg  
2388-P6B: <40 mg/kg



HM ID: 13  
0.5 MG Tank  
Floor 1

Interior  
Beige coating on concrete floor.

**2388-PCB1A, PCB1B, PCB1C:**

Aroclor-1016: ND  
Aroclor-1221: ND  
Aroclor-1232: ND  
**Aroclor-1242: 2.3 mg/kg**  
Aroclor-1248: ND  
**Aroclor-1254: 8.1 mg/kg**  
**Aroclor-1260: 18 mg/kg**  
Aroclor-1262: ND  
Aroclor-1268: ND  
**Total PCB: 28.4 mg/kg**



HM ID: 14  
0.5 MG Tank  
Floor 1

Interior  
Beige asphaltic base sealant on concrete sealant joint.

**2388-PCB2A, PCB2B, PCB2C:**

Aroclor-1016: ND  
Aroclor-1221: ND  
Aroclor-1232: ND  
**Aroclor-1242: 2.4 mg/kg**  
Aroclor-1248: ND  
**Aroclor-1254: 3.4 mg/kg**  
**Aroclor-1260: 4.7 mg/kg**  
Aroclor-1262: ND  
Aroclor-1268: ND  
**Total PCB: 10.5 mg/kg**

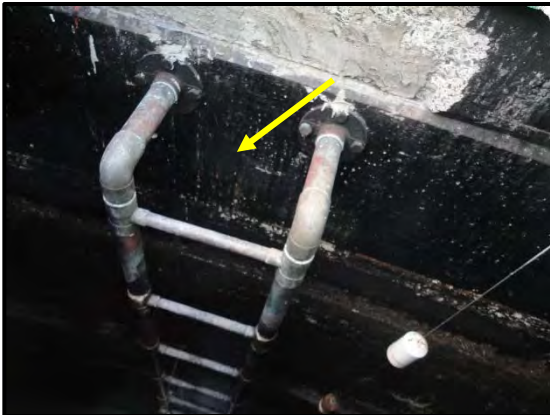


HM ID: 15  
0.5 MG Tank  
Floor 1

Interior  
Black coating on concrete wall.

**2388-PCB3A, PCB3B, PCB3C:**

Aroclor-1016: ND  
Aroclor-1221: ND  
Aroclor-1232: ND  
Aroclor-1242: ND  
Aroclor-1248: ND  
**Aroclor-1254: 38 mg/kg**  
**Aroclor-1260: 76 mg/kg**  
Aroclor-1262: ND  
Aroclor-1268: ND  
**Total PCB: 114 mg/kg**



HM ID: 15C1 (Confirmation Sample)  
0.5 MG Tank  
Floor 1

Interior  
Black coating on concrete wall.

**2388-PCB4A, PCB4B, PCB4C:**

Aroclor-1016: ND  
Aroclor-1221: ND  
Aroclor-1232: ND  
Aroclor-1242: ND  
Aroclor-1248: ND  
**Aroclor-1254: 73 mg/kg**  
**Aroclor-1260: 210 mg/kg**  
Aroclor-1262: ND  
Aroclor-1268: ND  
**Total PCB: 283 mg/kg**

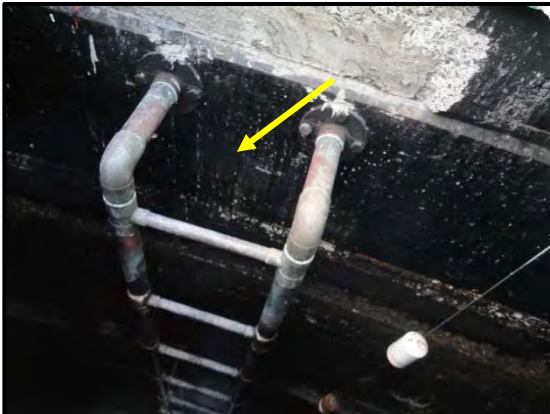


HM ID: 15C2 (Confirmation Sample)  
0.5 MG Tank  
Floor 1

Interior  
Black coating on concrete wall.

**2388-PCB4A, PCB4B, PCB4C:**

Aroclor-1016: ND  
Aroclor-1221: ND  
Aroclor-1232: ND  
Aroclor-1242: ND  
Aroclor-1248: ND  
**Aroclor-1254: 51 mg/kg**  
**Aroclor-1260: 170 mg/kg**  
Aroclor-1262: ND  
Aroclor-1268: ND  
**Total PCB: 221 mg/kg**



HM ID: 15C3 (Confirmation Sample)  
0.5 MG Tank  
Floor 1

Interior  
Black coating on concrete wall.

**2388-PCB4A, PCB4B, PCB4C:**

Aroclor-1016: ND  
Aroclor-1221: ND  
Aroclor-1232: ND  
Aroclor-1242: ND  
Aroclor-1248: ND  
**Aroclor-1254: 39 mg/kg**  
**Aroclor-1260: 170 mg/kg**  
Aroclor-1262: ND  
Aroclor-1268: ND  
**Total PCB: 209 mg/kg**



HM ID: 9C1 (Confirmation)  
0.5 MG Tank  
Floor 1

Interior  
Black coating on concrete wall.

Non-ACM  
2388-A7A: ND  
2388-A7B: ND  
2388-A7C: ND

\*Indicates that one or more asbestos fibers were detected by the point count method. While the <1% asbestos is not a regulated material, OSHA considers the trace amount as a health hazard.

## **APPENDIX E**

### **LABORATORY ANALYTICAL REPORTS**



# LA Testing

520 Mission Street South Pasadena, CA 91030

Tel/Fax: (323) 254-9960 / (323) 254-9982

<http://www.LATesting.com> / [pasadenalab@latesting.com](mailto:pasadenalab@latesting.com)

LA Testing Order: 321720066

Customer ID: 32MYOU50

Customer PO:

Project ID:

**Attention:** Akari Ihara  
Myounghee Noh & Associates, LLC  
99-1046 Iwaena Street  
Suite 210A  
Aiea, HI 96701

**Phone:** (808) 358-1421

**Fax:**

**Received Date:** 08/21/2017 9:20 AM

**Analysis Date:** 08/25/2017

**Collected Date:**

**Project:** 2388.3

## Test Report: Asbestos Analysis of Bulk Materials via EPA 600/R-93/116 Method using Polarized Light Microscopy

Sample	Description	Appearance	Non-Asbestos		Asbestos
			% Fibrous	% Non-Fibrous	% Type
2388.A1A <small>321720066-0001</small>	Ext Roof System - P/SC	Gray Non-Fibrous Homogeneous		100% Non-fibrous (Other)	None Detected
2388.A1B <small>321720066-0002</small>	Ext Roof System - P/SC	Green Non-Fibrous Homogeneous		100% Non-fibrous (Other)	None Detected
2388.A1C <small>321720066-0003</small>	Ext Roof System - P/SC	Green/Beige Non-Fibrous Homogeneous		100% Non-fibrous (Other)	None Detected
2388.A2A <small>321720066-0004</small>	Ext Vent - Gray cementitas	Gray Non-Fibrous Homogeneous		100% Non-fibrous (Other)	None Detected
2388.A2B <small>321720066-0005</small>	Ext Vent - Gray cementitas	Gray Non-Fibrous Homogeneous		100% Non-fibrous (Other)	None Detected
2388.A2C <small>321720066-0006</small>	Ext Vent - Gray cementitas	Gray Non-Fibrous Homogeneous		100% Non-fibrous (Other)	None Detected
2388.A3A-Coating <small>321720066-0007</small>	Lut Floor - beige coating	Beige/Orange Non-Fibrous Homogeneous		100% Non-fibrous (Other)	None Detected
2388.A3A-Cementitious Material <small>321720066-0007A</small>	Lut Floor - beige coating	Brown/Gray Non-Fibrous Homogeneous		100% Non-fibrous (Other)	<1% Chrysotile
2388.A3B-Coating <small>321720066-0008</small>	Lut Floor - beige coating	Beige/Orange Non-Fibrous Homogeneous		100% Non-fibrous (Other)	None Detected
2388.A3B-Cementitious Material <small>321720066-0008A</small>	Lut Floor - beige coating	Gray Non-Fibrous Homogeneous		100% Non-fibrous (Other)	<1% Chrysotile
2388.A3C <small>321720066-0009</small>	Lut Floor - beige coating	Beige/Orange Non-Fibrous Homogeneous		100% Non-fibrous (Other)	None Detected
2388.A4A-Coating <small>321720066-0010</small>	Lut Sealant Joint - beige asphalt base sealant	Orange Non-Fibrous Homogeneous		100% Non-fibrous (Other)	None Detected
2388.A4A-Texture <small>321720066-0010A</small>	Lut Sealant Joint - beige asphalt base sealant	Gray Non-Fibrous Homogeneous		100% Non-fibrous (Other)	None Detected
2388.A4A-Tar <small>321720066-0010B</small>	Lut Sealant Joint - beige asphalt base sealant	Black Non-Fibrous Homogeneous		100% Non-fibrous (Other)	None Detected
2388.A4B-Coating <small>321720066-0011</small>	Lut Sealant Joint - beige asphalt base sealant	Orange Non-Fibrous Homogeneous		100% Non-fibrous (Other)	None Detected

Initial report from: 08/25/2017 14:24:05



# LA Testing

520 Mission Street South Pasadena, CA 91030

Tel/Fax: (323) 254-9960 / (323) 254-9982

<http://www.LATesting.com> / [pasadenalab@lateesting.com](mailto:pasadenalab@lateesting.com)

LA Testing Order: 321720066

Customer ID: 32MYOU50

Customer PO:

Project ID:

## Test Report: Asbestos Analysis of Bulk Materials via EPA 600/R-93/116 Method using Polarized Light Microscopy

Sample	Description	Appearance	Non-Asbestos		Asbestos
			% Fibrous	% Non-Fibrous	% Type
2388.A4B-Texture <small>321720066-0011A</small>	Lut Sealant Joint - beige asphalt base sealant	Gray Non-Fibrous Homogeneous		100% Non-fibrous (Other)	None Detected
2388.A4B-Tar <small>321720066-0011B</small>	Lut Sealant Joint - beige asphalt base sealant	Black Non-Fibrous Homogeneous		100% Non-fibrous (Other)	None Detected
2388.A4C <small>321720066-0012</small>	Lut Sealant Joint - beige asphalt base sealant	Black Non-Fibrous Homogeneous		100% Non-fibrous (Other)	None Detected
2388.A5A <small>321720066-0013</small>	Lut Walls - black coating	Black Non-Fibrous Homogeneous		100% Non-fibrous (Other)	None Detected
2388.A5B <small>321720066-0014</small>	Lut Walls - black coating	Black Non-Fibrous Homogeneous		100% Non-fibrous (Other)	None Detected
2388.A5C <small>321720066-0015</small>	Lut Walls - black coating	Black Non-Fibrous Homogeneous		100% Non-fibrous (Other)	None Detected
2388.A6A <small>321720066-0016</small>	Ext Walls - orange P/SC	Orange Non-Fibrous Homogeneous		100% Non-fibrous (Other)	None Detected
2388.A6B-Texture Paint <small>321720066-0017</small>	Ext Walls - orange P/SC	Orange Non-Fibrous Homogeneous		100% Non-fibrous (Other)	None Detected
2388.A6B-Skim Coat <small>321720066-0017A</small>	Ext Walls - orange P/SC	Gray Non-Fibrous Homogeneous		100% Non-fibrous (Other)	None Detected
2388.A6C-Texture Paint/Skim Coat <small>321720066-0018</small>	Ext Walls - orange P/SC	Gray/Orange Non-Fibrous Heterogeneous		100% Non-fibrous (Other)	None Detected

Unable to separate.

Analyst(s)

Julie Vong (6)

Kieu-anh Pham Duong (19)

Jerry Drapala Ph.D, Laboratory Manager  
or Other Approved Signatory

EMSL maintains liability limited to cost of analysis. This report relates only to the samples reported and may not be reproduced, except in full, without written approval by EMSL. EMSL bears no responsibility for sample collection activities or analytical method limitations. Interpretation and use of test results are the responsibility of the client. This report must not be used by the client to claim product certification, approval, or endorsement by NVLAP, NIST or any agency of the federal government. Non-friable organically bound materials present a problem matrix and therefore EMSL recommends gravimetric reduction prior to analysis. Samples received in good condition unless otherwise noted. Estimated accuracy, precision and uncertainty data available upon request. Unless requested by the client, building materials manufactured with multiple layers (i.e. linoleum, wallboard, etc.) are reported as a single sample. Reporting limit is 1%

Samples analyzed by LA Testing South Pasadena, CA NVLAP Lab Code 200232-0, CA ELAP 2283

Initial report from: 08/25/2017 14:24:05





**Asbestos Chain of Custody**  
**EMSL Order Number (Lab Use Only):**

#321720066

LATESTING  
 520 MISSION STREET  
 SOUTH PASADENA, CA 91030  
 PHONE: (800)-303-0047  
 FAX: (323)-254-9962

Company : Myounghee Noh & Associates L.L.C		EMSL-Bill to: <input type="checkbox"/> Same <input type="checkbox"/> Different If Bill to is Different note instructions in Comments**	
Street: 99-1046 Iwaena St.		Third Party Billing requires written authorization from third party	
City: Aiea	State/Province: Hawaii	Zip/Postal Code:	Country:
Report To (Name): Akari		Telephone #:	
Email Address:		Fax #:	Purchase Order:
Project Name/Number: 2388-3		Please Provide Results: <input type="checkbox"/> Fax <input type="checkbox"/> Email <input type="checkbox"/> Mail	
U.S. State Samples Taken: 4		Connecticut Samples: <input type="checkbox"/> Commercial <input type="checkbox"/> Residential	

**Turnaround Time (TAT) Options\* - Please Check**

3 Hour  
  6 Hour  
  24 Hour  
  48 Hour  
  72 Hour  
  96 Hour  
 1 Week  
 2 Week

\*For TEM Air 3 hr through 6 hr, please call ahead to schedule. \*There is a premium charge for 3 Hour TEM AHERA or EPA Level II TAT. You will be asked to sign an authorization form for this service. Analysis completed in accordance with EMSL's Terms and Conditions located in the Analytical Price Guide.

<b>PCM - Air</b> <input type="checkbox"/> Check if samples are from NY <input type="checkbox"/> NIOSH 7400 <input type="checkbox"/> w/ OSHA 8hr. TWA	<b>TEM - Air</b> <input type="checkbox"/> 4-4.5hr TAT (AHERA only) <input type="checkbox"/> AHERA 40 CFR, Part 763 <input type="checkbox"/> NIOSH 7402 <input type="checkbox"/> EPA Level II <input type="checkbox"/> ISO 10312	<b>TEM- Dust</b> <input type="checkbox"/> Microvac - ASTM D 5755 <input type="checkbox"/> Wipe - ASTM D6480 <input type="checkbox"/> Carpet Sonication (EPA 600/J-93/167)
<b>PLM - Bulk (reporting limit)</b> <input checked="" type="checkbox"/> PLM EPA 600/R-93/116 (<1%) <input type="checkbox"/> PLM EPA NOB (<1%) Point Count <input type="checkbox"/> 400 (<0.25%) <input type="checkbox"/> 1000 (<0.1%) Point Count w/Gravimetric <input type="checkbox"/> 400 (<0.25%) <input type="checkbox"/> 1000 (<0.1%) <input type="checkbox"/> NYS 198.1 (friable in NY) <input type="checkbox"/> NYS 198.6 NOB (non-friable-NY) <input type="checkbox"/> NIOSH 9002 (<1%)	<b>TEM - Bulk</b> <input type="checkbox"/> TEM EPA NOB <input type="checkbox"/> NYS NOB 198.4 (non-friable-NY) <input type="checkbox"/> Chatfield SOP <input type="checkbox"/> TEM Mass Analysis-EPA 600 sec. 2.5 <b>TEM - Water: EPA 100.2</b> Fibers >10µm <input type="checkbox"/> Waste <input type="checkbox"/> Drinking All Fiber Sizes <input type="checkbox"/> Waste <input type="checkbox"/> Drinking	<b>Soil/Rock/Vermiculite</b> <input type="checkbox"/> PLM CARB 435 - A (0.25% sensitivity) <input type="checkbox"/> PLM CARB 435 - B (0.1% sensitivity) <input type="checkbox"/> TEM CARB 435 - B (0.1% sensitivity) <input type="checkbox"/> TEM CARB 435 - C (0.01% sensitivity) <input type="checkbox"/> TEM Qual. via Filtration Technique <input type="checkbox"/> TEM Qual. via Drop-Mount Technique <b>Other:</b> <input type="checkbox"/>

Check For Positive Stop - Clearly Identify Homogenous Group      Filter Pore Size (Air Samples):  0.8µm  0.45µm

Samplers Name: Akari      Samplers Signature: *Akari*

Sample #	Sample Description	Volume/Area (Air) HA # (Bulk)	Date/Time Sampled
2388-A1A	bulk		
↓ ↓ B			
↓			
2388-A6A	bulk		
↓ ↓ B			

Client Sample # (s): 2388-A1A ~ 2388-A6C      Total # of Samples: 18

Relinquished (Client): *Akari*      Date: 8.18.17      Time:

Received (Lab): DFlones (EMSL FedEx)      Date: 8/21/17      Time: 9:20 am

Comments/Special Instructions:

**Hazardous Homogeneous Materials and Sampling Survey Field Form: Asbestos**

Project Number: 2388 3 Location: DOW Kekaha 0.5MG Storage Tank Inspector Initials: AI Survey Dates and Times: 8.17.17

HM ID	Building	Flr.	Rooms	Locations	Material Color	Material	Substrate	Condition	Friable ACM	Area Sq. ft or L. ft	Hatch Color
									Type		
2	0.5 MG Tank	R	ext	Roof systems	H. blue	P/S	cc	G F P	Y <input checked="" type="checkbox"/> N TSI <input checked="" type="checkbox"/> S M	2,000	-

Sample ID	Room Sampled	Sample Location	PIC ID	Notes
2388-A 1 A	ext	Roof systems	1491	
2388-A 1 B	↓	↓		
2388-A 1 C	↓	↓		

HM ID	Building	Flr.	Rooms	Locations	Material Color	Material	Substrate	Condition	Friable ACM	Area Sq. ft or L. ft	Hatch Color
									Type		
3	0.5 MG Tank	R	ext	vent	Gray	concrete	cc	G F P	Y <input checked="" type="checkbox"/> N TSI <input checked="" type="checkbox"/> S M	5	-

Sample ID	Room Sampled	Sample Location	PIC ID	Notes
2388-A 2 A	ext	vent	1493	
2388-A 2 B	↓	↓		
2388-A 2 C	↓	↓		

HM ID	Building	Flr.	Rooms	Locations	Material Color	Material	Substrate	Condition	Friable ACM	Area Sq. ft or L. ft	Hatch Color
									Type		
7	0.5 MG Tank		int	floor	beige	concrete	cc	G F P	Y <input checked="" type="checkbox"/> N TSI <input checked="" type="checkbox"/> S M	5,000	-

Sample ID	Room Sampled	Sample Location	PIC ID	Notes
2388-A 3 A	int	floor	1504	
2388-A 3 B	↓			
2388-A 3 C	↓			

#321720066

Order ID: 321720066

**Hazardous Homogeneous Materials and Sampling Survey Field Form: Asbestos**

Project Number: 2388 3 Location: DOW Kekaha 0.5MG Storage Tank Inspector Initials: AI Survey Dates and Times: 6.17.17

HM ID	Building	Flr.	Rooms	Locations	Material Color	Material	Substrate	Condition	Friable ACM	Area Sq. ft or L. ft	Hatch Color
									Type		
8	0.5MG tank	1	int	Sealant Joint	Grey	Asphalt concrete sealant	CC	GFP	Y (N) TSI S (M)	5,000 4,000	-

Sample ID	Room Sampled	Sample Location	PIC ID	Notes
2388-A 4 A	int	Sealant Joint	1501	
2388-A 4 B	↓	↓		
2388-A 4 C	↓	↓		

HM ID	Building	Flr.	Rooms	Locations	Material Color	Material	Substrate	Condition	Friable ACM	Area Sq. ft or L. ft	Hatch Color
									Type		
9	0.5MG Tank	1	int	walls	Grey	<del>P/S</del> black coating	CC	GFP	Y (N) TSI S (M)	10,000	-

Sample ID	Room Sampled	Sample Location	PIC ID	Notes
2388-A 5 A	int	walls	1501	
2388-A 5 B	↓	↓		
2388-A 5 C	↓	↓		

HM ID	Building	Flr.	Rooms	Locations	Material Color	Material	Substrate	Condition	Friable ACM	Area Sq. ft or L. ft	Hatch Color
									Type		
10	0.5MG Tank	1	ext	walls	Grey	P/SC	CC	GFP	Y (N) TSI S (M)	10,000	-

Sample ID	Room Sampled	Sample Location	PIC ID	Notes
2388-A 6 A	ext	walls	1509	
2388-A 6 B	↓	↓		
2388-A 6 C	↓	↓		

Page 3 of 4



# EMSL Analytical, Inc.

200 Route 130 North Cinnaminson, NJ 08077

Tel/Fax: (800) 220-3675 / (856) 786-5974

<http://www.EMSL.com> / [cinnaslab@EMSL.com](mailto:cinnaslab@EMSL.com)

EMSL Order: 041731009

Customer ID: 32MYOU50

Customer PO:

Project ID:

**Attention:** Akari Ihara  
Myounghee Noh & Associates, LLC  
99-1046 Iwaena Street  
Suite 210A  
Aiea, HI 96701

**Phone:** (808) 358-1421

**Fax:**

**Received Date:** 10/25/2017 4:30 PM

**Analysis Date:** 10/27/2017

**Collected Date:**

**Project:** 23883

## Test Report: Asbestos Analysis of Bulk Materials via EPA 600/R-93/116 Method using Polarized Light Microscopy

Sample	Description	Appearance	Non-Asbestos		Asbestos
			% Fibrous	% Non-Fibrous	% Type
2388-A7A <small>041731009-0001</small>	P2388-PCB4A	Brown/Black Non-Fibrous Homogeneous		100% Non-fibrous (Other)	None Detected
2388-A7B <small>041731009-0002</small>	P2388-PCB4B	Black Non-Fibrous Homogeneous		100% Non-fibrous (Other)	None Detected
2388-A7C <small>041731009-0003</small>	P2388-PCB4C	Black Non-Fibrous Homogeneous		100% Non-fibrous (Other)	None Detected

Analyst(s)

Steven Quinn (2)

Seri Smith (1)

Benjamin Ellis, Laboratory Manager  
or Other Approved Signatory

EMSL maintains liability limited to cost of analysis. This report relates only to the samples reported and may not be reproduced, except in full, without written approval by EMSL. EMSL bears no responsibility for sample collection activities or analytical method limitations. Interpretation and use of test results are the responsibility of the client. This report must not be used by the client to claim product certification, approval, or endorsement by NVLAP, NIST or any agency of the federal government. Non-friable organically bound materials present a problem matrix and therefore EMSL recommends gravimetric reduction prior to analysis. Samples received in good condition unless otherwise noted. Estimated accuracy, precision and uncertainty data available upon request. Unless requested by the client, building materials manufactured with multiple layers (i.e. linoleum, wallboard, etc.) are reported as a single sample. Reporting limit is 1%

Samples analyzed by EMSL Analytical, Inc. Cinnaminson, NJ NVLAP Lab Code 101048-0, AIHA-LAP, LLC-IHLAP Lab 100194, NYS ELAP 10872, NJ DEP 03036, PA ID# 68-00367

Initial report from: 10/27/2017 18:10:40



**Asbestos Chain of Custody**

**EMSL Order Number (Lab Use Only):**

041731009

LATESTING  
5200 EMISSION STREET  
SOUTH PASADENA, CA 91030  
CINNAMON POWER (800) 803-0047  
FAX: (323) 254-9962

2017 OCT 25 P 4:32

**Company:** Myounghee Noh & Associates L.L.C  
**Street:** 99-1046 Iwaena St.  
**City:** Aiea **State/Province:** Hawaii **Zip/Postal Code:** **Country:**  
**Report To (Name):** Akari **Telephone #:**  
**Email Address:** **Fax #:** **Purchase Order:**  
**Project Name/Number:** 2388.3 **Please Provide Results:**  Fax  Email  Mail  
**U.S. State Samples Taken:** HI **Connecticut Samples:**  Commercial  Residential

**Turnaround Time (TAT) Options\* - Please Check**  
 3 Hour  6 Hour  24 Hour  48 Hour  72 Hour  96 Hour  1 Week  2 Week

\*For TEM Air 3 hr through 6 hr, please call ahead to schedule. There is a premium charge for 3 Hour TEM AHERA or EPA Level II TAT. You will be asked to sign an authorization form for this service. Analysis completed in accordance with EMSL's Terms and Conditions located in the Analytical Price Guide.

<p><b>PCM - Air</b> <input type="checkbox"/> Check if samples are from NY  <input type="checkbox"/> NIOSH 7400  <input type="checkbox"/> w/ OSHA 8hr. TWA</p> <p><b>PLM - Bulk (reporting limit)</b>  <input checked="" type="checkbox"/> PLM EPA 600/R-93/116 (&lt;1%)  <input type="checkbox"/> PLM EPA NOB (&lt;1%)                  Point Count  <input type="checkbox"/> 400 (&lt;0.25%) <input type="checkbox"/> 1000 (&lt;0.1%)                  Point Count w/Gravimetric  <input type="checkbox"/> 400 (&lt;0.25%) <input type="checkbox"/> 1000 (&lt;0.1%)  <input type="checkbox"/> NYS 198.1 (friable in NY)  <input type="checkbox"/> NYS 198.6 NOB (non-friable-NY)  <input type="checkbox"/> NIOSH 9002 (&lt;1%)</p>	<p><b>TEM - Air</b> <input type="checkbox"/> 4-4.5hr TAT (AHERA only)  <input type="checkbox"/> AHERA 40 CFR, Part 763  <input type="checkbox"/> NIOSH 7402  <input type="checkbox"/> EPA Level II  <input type="checkbox"/> ISO 10312</p> <p><b>TEM - Bulk</b>  <input type="checkbox"/> TEM EPA NOB  <input type="checkbox"/> NYS NOB 198.4 (non-friable-NY)  <input type="checkbox"/> Chatfield SOP  <input type="checkbox"/> TEM Mass Analysis-EPA 600 sec. 2.5</p> <p><b>TEM - Water:</b> EPA 100.2                  Fibers &gt;10µm <input type="checkbox"/> Waste <input type="checkbox"/> Drinking                  All Fiber Sizes <input type="checkbox"/> Waste <input type="checkbox"/> Drinking</p>	<p><b>TEM- Dust</b>  <input type="checkbox"/> Microvac - ASTM D 5755  <input type="checkbox"/> Wipe - ASTM D6480  <input type="checkbox"/> Carpet Sonication (EPA 600/J-93/167)</p> <p><b>Soil/Rock/Vermiculite</b>  <input type="checkbox"/> PLM CARB 435 - A (0.25% sensitivity)  <input type="checkbox"/> PLM CARB 435 - B (0.1% sensitivity)  <input type="checkbox"/> TEM CARB 435 - B (0.1% sensitivity)  <input type="checkbox"/> TEM CARB 435 - C (0.01% sensitivity)  <input type="checkbox"/> TEM Qual. via Filtration Technique  <input type="checkbox"/> TEM Qual. via Drop-Mount Technique</p> <p><b>Other:</b>  <input type="checkbox"/></p>
---	--	--

Check For Positive Stop - Clearly Identify Homogenous Group **Filter Pore Size (Air Samples):**  0.8µm  0.45µm

**Samplers Name:** **Samplers Signature:** *Akari*

Sample #	Sample Description	Volume/Area (Air) HA # (Bulk)	Date/Time Sampled
2388. A7A	Use PCB samples (P2388. PCB4A		
↓ ↓ B	↓ ↓ ↓ B		
↓ ↓ C	↓ ↓ ↓ C		

**Client Sample # (s):** 2388. A7A, B, C **Total # of Samples:** 3

**Relinquished (Client):** *Akari* **Date:** 10.23.17 **Time:**

**Received (Lab):** *(Signature)* **Date:** 10-25-17 **Time:** 4:30pm

**Comments/Special Instructions:**

#321720066

2

ORIGIN ID: NAVE (000) 484-9214  
MOULDER, NICHOL ASSOCIATES, LLC  
86-1040 IMBENA STREET SUITE 210A  
ALBA, HI 96701  
UNITED STATES US

SHIP DATE: 18AUG17  
C/D: 1022085800MS02000

TO SAMPLE RECEIVING  
LA TESTING  
520 MISSION STREET

SOUTH PASADENA CA 91030  
REF: AR-ME/VA 20M01050  
PZY

58J157E101C



RETURNS MON-FRI  
PRIORITY OVERNIGHT

TRK# 7953 2369 9011

91030

CA-US



**IMPORTANT! Do not duplicate this label. Each package must contain a unique tracking number in order to maintain tracking and billing integrity.**

Use of this FedEx shipping label is subject to the following restrictions and conditions:

**Disclaimer**

1. The shipment must be via FedEx packaging (FedEx envelope pack or FedEx box), this label is not valid for use on non-standard packages nor coolers.
2. Valid for shipment of the following samples only: Lead analysis of paint chips, air samples, or wipe samples; Absorbent testing of bulk material samples, wipe/dust samples, or air sample cassettes; Microbiology air samples or bulk samples; tape lift samples, and/or snab samples. This label and shipping is not valid for shipment of any sample that requires a cooler or any other sample type not specifically described herein.
3. The package shipment must exceed a minimum of \$100 in analytical fees. If this minimum is not met, a minimum shipping fee of \$15 will be added to the analysis invoice.
4. Not valid for the shipping of any hazardous materials or items prohibited to be shipped by these means.
5. Valid for only those accounts pre-approved to use this service. This courtesy shipping service may be terminated at any time by LA Testing for any customer accounts that are not in good standing due to late payment (COD Status, or any other reason in the sole determination of LA Testing.
6. Any additional fees, including, but not limited to, custom pickup fees from FedEx, excessive weight fees, and any surcharge items added by FedEx, associated with this label/package will be back-charged to the customer that made the shipment.
7. This label is not valid for weekend or holiday deliveries.
8. Excludes Summa Centers, Equipment Rental and Loaner Returns.
9. Valid in the Continental United States and within Canada.



# LA Testing

520 Mission Street South Pasadena, CA 91030  
Phone/Fax: (323) 254-9960 / (323) 254-9982  
<http://www.LATesting.com> / [pasadenalab@lateesting.com](mailto:pasadenalab@lateesting.com)

LA Testing Order: 321720371  
Customer ID: 32MYOU50  
Customer PO:  
Project ID:

Attention: Akari Ihara  
Myounghee Noh & Associates, LLC  
99-1046 Iwaena Street  
Suite 210A  
Aiea, HI 96701

Phone: (808) 358-1421  
Fax:  
Received: 08/25/2017 4:38 PM  
Analysis Date: 08/29/2017  
Collected:

Project: Re-analysis 321720066 / 2388.3

## Test Report: Asbestos Analysis of Bulk Materials via EPA 600/R-93/116 Method using Polarized Light Microscopy. Quantitation using 400 Point Count Procedure

Sample	Description	Appearance	Non-Asbestos		Asbestos
			% Fibrous	% Non-Fibrous	% Type
2388.A3A-2388.A3 A-Cementitious Material 321720371-0001	Lut Floor - Beige	Brown/Gray Non-Fibrous Homogeneous		100% Non-fibrous (Other)	<0.25% Chrysotile
2388.A3B-2388.A3 A-Cementitious Material 321720371-0002	Lut Floor - Beige	Gray Non-Fibrous Homogeneous		100% Non-fibrous (Other)	<0.25% Chrysotile

Analyst(s)

Kieu-anh Pham Duong (2)

Jerry Drapala Ph.D, Laboratory Manager  
or other approved signatory

Disclaimer: Some samples may contain asbestos fibers present in dimensions below PLM resolution limits. The limit of detection as stated in the method is 0.25%. EMSL Analytical Inc suggests that samples reported as <0.25% or none detected undergo additional analysis via TEM. The above test report relates only to the items tested. This report may not be reproduced, except in full, without written approval of EMSL Analytical Inc. This test report must not be used by the client to claim product endorsement by NVLAP or any agency of the United States Government. EMSL Analytical Inc., bears no responsibility for sample collection activities, analytical method limitations, or the accuracy of results when requested to separate layered samples. EMSL Analytical Inc., liability is limited to the cost of sample analysis. The test results contained within this report meet the requirements of NELAC unless otherwise noted. Samples received in good condition unless otherwise noted. Unless requested by the client, building materials manufactured with multiple layers (i.e. linoleum, wallboard, etc.) are reported as a single sample.

Samples analyzed by LA Testing South Pasadena, CA NVLAP Lab Code 200232-0

Initial report from: 08/29/2017 16:04:15

**Mulcahy, Brandon**

---

**From:** Akari Ihara <akari@noh-associates.com>  
**Sent:** Friday, August 25, 2017 4:38 PM  
**To:** Vong, Julie; LA Testing Lab - Pasadena  
**Subject:** RE: LA Testing report, COC for order(s) 321720066 (321720066 - 2388.3)

Aloha,  
Can we get a 400 point count on the 2388.A3A,B,C (<1%). With a three day TAT.

Thank you,

**From:** LA Testing (South Pasadena) [mailto:pasadenalab@latesting.com]  
**Sent:** Friday, August 25, 2017 11:34 AM  
**To:** Akari Ihara <akari@noh-associates.com>  
**Subject:** LA Testing report, COC for order(s) 321720066 (321720066 - 2388.3)

Report, COC for order(s):  
321720066 - 2388.3



**Julie Vong** | *Laboratory Analyst*

**LA Testing** | 520 Mission Street | South Pasadena, CA 91030  
Phone: 323-254-9960 | Fax: 323-254-9982 | Toll Free: 800-303-0047  
Lab Hours: Monday - Friday 8AM - 6PM, Saturday 9AM - 5PM, Sunday On-Call

Some of the resources LATesting, Inc. offers to our clients:

[LABConnect](#) | [Order Products](#) | [Client Corner](#) | [Training](#) | [Additional Resources](#) | [Sampling Videos](#)

---

"This email may contain privileged and confidential information and is solely for the use of the sender's intended recipient(s). **If you are not the intended recipient of this communication, you are hereby notified that any unauthorized review, use, dissemination, distribution, downloading, or copying of this communication is strictly prohibited.** If you received this email in error, please notify the sender by reply email and delete all copies and attachments. Thank you."





**LA Testing**

520 Mission Street South Pasadena, CA 91030  
 Tel/Fax: (323) 254-9960 / (323) 254-9982  
 http://www.LATesting.com / pasadenalab@latesting.com

**LA Testing Order:** 321720066  
**Customer ID:** 32MYOU50  
**Customer PO:**  
**Project ID:**

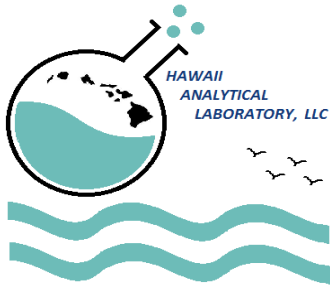
**Attention:** Akari Ihara  
 Myounghee Noh & Associates, LLC  
 99-1046 Iwaena Street  
 Suite 210A  
 Aiea, HI 96701  
**Project:** 2388.3

**Phone:** (808) 358-1421  
**Fax:**  
**Received Date:** 08/21/2017 9:20 AM  
**Analysis Date:** 08/25/2017  
**Collected Date:**

**Test Report: Asbestos Analysis of Bulk Materials via EPA 600/R-93/116 Method using Polarized Light Microscopy**

Sample	Description	Appearance	Non-Asbestos		Asbestos
			% Fibrous	% Non-Fibrous	% Type
2388.A1A <small>321720066-0001</small>	Ext Roof System - P/SC	Gray Non-Fibrous Homogeneous		100% Non-fibrous (Other)	None Detected
2388.A1B <small>321720066-0002</small>	Ext Roof System - P/SC	Green Non-Fibrous Homogeneous		100% Non-fibrous (Other)	None Detected
2388.A1C <small>321720066-0003</small>	Ext Roof System - P/SC	Green/Beige Non-Fibrous Homogeneous		100% Non-fibrous (Other)	None Detected
2388.A2A <small>321720066-0004</small>	Ext Vent - Gray cementitas	Gray Non-Fibrous Homogeneous		100% Non-fibrous (Other)	None Detected
2388.A2B <small>321720066-0005</small>	Ext Vent - Gray cementitas	Gray Non-Fibrous Homogeneous		100% Non-fibrous (Other)	None Detected
2388.A2C <small>321720066-0006</small>	Ext Vent - Gray cementitas	Gray Non-Fibrous Homogeneous		100% Non-fibrous (Other)	None Detected
2388.A3A-Coating <small>321720066-0007</small>	Lut Floor - beige coating	Beige/Orange Non-Fibrous Homogeneous		100% Non-fibrous (Other)	None Detected
2388.A3A-Cementitious Material <small>321720066-0007A</small>	Lut Floor - beige coating	Brown/Gray Non-Fibrous Homogeneous		100% Non-fibrous (Other)	<1% Chrysotile
2388.A3B-Coating <small>321720066-0008</small>	Lut Floor - beige coating	Beige/Orange Non-Fibrous Homogeneous		100% Non-fibrous (Other)	None Detected
2388.A3B-Cementitious Material <small>321720066-0008A</small>	Lut Floor - beige coating	Gray Non-Fibrous Homogeneous		100% Non-fibrous (Other)	<1% Chrysotile
2388.A3C <small>321720066-0009</small>	Lut Floor - beige coating	Beige/Orange Non-Fibrous Homogeneous		100% Non-fibrous (Other)	None Detected
2388.A4A-Coating <small>321720066-0010</small>	Lut Sealant Joint - beige asphalt base sealant	Orange Non-Fibrous Homogeneous		100% Non-fibrous (Other)	None Detected
2388.A4A-Texture <small>321720066-0010A</small>	Lut Sealant Joint - beige asphalt base sealant	Gray Non-Fibrous Homogeneous		100% Non-fibrous (Other)	None Detected
2388.A4A-Tar <small>321720066-0010B</small>	Lut Sealant Joint - beige asphalt base sealant	Black Non-Fibrous Homogeneous		100% Non-fibrous (Other)	None Detected
2388.A4B-Coating <small>321720066-0011</small>	Lut Sealant Joint - beige asphalt base sealant	Orange Non-Fibrous Homogeneous		100% Non-fibrous (Other)	None Detected

Initial report from: 08/25/2017 14:24:05



# Hawaii Analytical Laboratory ANALYTICAL REPORT

Friday, August 25, 2017

Ms. Myounghee Noh  
 Myounghee Noh & Associates  
 99-1046 Iwaena St. Suite 210A  
 Aiea HI 96701

**Phone Number:** (808) 484-9214  
**Facsimile:** (808) 484-4660  
**Email:** m\_noh@noh-associates.com

**Lab Job No:** 20176765  
**Date Submitted:** 8/18/2017  
**Your Project:** DOW Kekaha 0.5 MG Tank, 8/17/2017

## Lead, total (paint chips)

NIOSH Method: 7082m LEAD by FAAS

Sample No.	Your Sample Description	Results	Units	Date Analyzed
201737463	2388-P1A	1200	mg/kg	8/23/2017
Comments				
201737464	2388-P1B	710	mg/kg	8/23/2017
Comments				
201737465	2388-P2A	55000	mg/kg	8/23/2017
Comments				
201737466	2388-P2B	41000	mg/kg	8/23/2017
Comments				
201737467	2388-P3A	1400	mg/kg	8/23/2017
Comments				
201737468	2388-P3B	1200	mg/kg	8/23/2017
Comments				
201737469	2388-P4A	41000	mg/kg	8/23/2017
Comments				
201737470	2388-P4B	40000	mg/kg	8/23/2017
Comments				

Hawaii Analytical Laboratory (101812) is accredited by the AIHA LAP, LLC in the EMLAP, IHLAP, and ELLAP programs for the scope of work listed on [www.aihaaccreditedlabs.org](http://www.aihaaccreditedlabs.org), in accordance with the recognized ISO/ IEC 17025:2005.  
 Controlled doc.: Lead Report, rev. 3 - 20161017

Ms. Myounghee Noh  
Myounghee Noh & Associates  
99-1046 Iwaena St. Suite 210A  
Aiea HI 96701

**Phone Number:** (808) 484-9214  
**Facsimile:** (808) 484-4660  
**Email:** m\_noh@noh-associates.com

**Lab Job No:** 20176765  
**Date Submitted:** 8/18/2017  
**Your Project:** DOW Kekaha 0.5 MG Tank, 8/17/2017

## Lead, total (paint chips)

NIOSH Method: 7082m LEAD by FAAS

Sample No.	Your Sample Description	Results	Units	Date Analyzed
201737471	2388-P5A	< 40	mg/kg	8/23/2017
Comments				
201737472	2388-P5B	< 40	mg/kg	8/23/2017
Comments				
201737473	2388-P6A	< 40	mg/kg	8/23/2017
Comments				
201737474	2388-P6B	< 40	mg/kg	8/23/2017
Comments				


All Quality Control data are acceptable unless otherwise noted.  
MRL for lead air is 5ug.  
MRL for lead wipe is 10ug.  
MRL for lead paint or soil is 40 mg/kg for a 0.25g sample.

### General Comments

The sample[s] analysis subject of this analytical report were conducted in general accordance with the procedures associated with the "analytical method" referenced above. Modifications to this methodology may have been made based upon the analyst's professional judgment and / or sample matrix effects encountered. The analysis of sample relates only to the sample analyzed, and may or may not be representative of the original source of the material submitted for our analysis. All analysts participate in interlaboratory quality control testing to continuously document proficiency. This report is not to be duplicated except in full without the expressed written permission of Hawaii Analytical Laboratory. This report should not be construed as an endorsement for a product or a service by the AIHA LAP, LLC or any affiliated organizations. Sample and associated sampling / collection data is reported as provided by client. TWA values have been calculated based on information supplied by the client that the laboratory has not independently verified. Results have not been corrected for blank determinations unless noted in remarks. Unless otherwise indicated the sample condition at the time of receipt was acceptable.

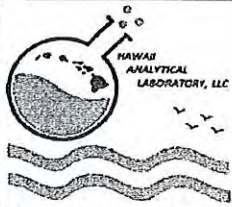
### Results and Symbols Definitions

> This testing result is greater than the numerical value listed.  
< This testing result is less than the numerical value listed.  
# = Analytical methods marked with an "#" are not within our AIHA LAP, LLC Scope of Accreditation.  
MRL = Method Reporting Limit.



**Jennifer Hsu Liao**  
**Laboratory Manager**

Hawaii Analytical Laboratory (101812) is accredited by the AIHA LAP, LLC in the EMLAP, IHLAP, and ELLAP programs for the scope of work listed on [www.aihaaccreditedlabs.org](http://www.aihaaccreditedlabs.org), in accordance with the recognized ISO/ IEC 17025:2005.  
Controlled doc.: Lead Report, rev. 3 - 20161017



3615 Harding Avenue, Suite 308  
 Honolulu, HI 96816  
 PH: 808-735-0422  
 FAX: 808-735-0047

**Need Results By\*:**

- 5 Working Days
- 4 Working Days
- 72 hour
- 48 hour
- 24 Hour
- Rush - 6 hours
- Immediate - 4 hrs or less

New Client?

Report To\* : Myounghee Noh  
 Company : Myounghee Noh & Associates, LLC  
 Address\* : 99-1046 Iwaena Street, 210A  
 Aiea, HI 96701  
 Phone / Cell No.\* : 808-484-9214  
 Report results to :  
 via email or fax :  
 or verbal :

Invoice To\* : Myounghee Noh & Associates, LLC  
 Company :  
 Address\* : 99-1046 Iwaena Street, 210A  
 Aiea, HI 96701  
 Phone / Cell No.\* : 808-484-9214  
 Purchase Order No. :  
 Email Invoice To :

Site/Project Name: DOW Kekaha 0.5 MG Tank Client Project No.: 2388.2 Sampled By: AI

Comments / Special Instructions:

PLM POSITIVE STOP Instructions:

- Positive stop per SAMPLE
- Positive stop per LAYER

**LAB USE ONLY**

Lab Report No.:  
**20176765**

Sample Identification* (Maximum of 30 Characters)	Date Sampled* (mm/dd/yy)	Collection Medium	Sample Area / Air Volume	Analysis Requested*	Method Reference	Lab ID
<u>2388-PIA</u> <u>L ↓ B</u>	<u>8.17.17</u>	<u>PoChrp</u>	<u>NA</u>	<u>PoChrp</u>		
<u>2388-PIA</u> <u>L ↓ B</u>						

Relinquished By (Print and Sign) 	Date/Time <u>1 8.18.17</u>	Received By (Print and Sign) <u>Anne Antin</u>	Date/Time <u>08-18-17 P01:44 RCVD</u>
--------------------------------------	-------------------------------	---	--

Sample description can be paint chips, concrete, specific sample collection location, etc...  
 If matrix is 'soil', please specify if it is a FOREIGN SOIL SAMPLE (outside Hawaii) in the comment section.  
 All samples submitted are subject to Hawaii Analytical Laboratory terms and conditions.  
 \*Required fields, failure to complete these fields may result in a delay in your samples being processed.  
 Rev 20140701

### Hazardous Homogeneous Materials and Sampling Survey Field Form: Lead Paint

6765

Project Number: 2388 3 Location: DOW Kekaha 0.5MG Storage Tank

Inspector Initials: AI

Survey Dates and Times: 8.17.17

HM ID	Building	Flr.	Rooms	Locations	Material Color	Material	Substrate	Condition	Area Sq. ft or L. ft	Hatch Color
1	0.5MG Res Tank	R	ext	Roofing System	lt blue	P	CC	GⓅP	2,000 1700	
Sample ID		Room Sampled		Sample Location		PIC ID		Notes		
2388-P 1 A		ext 201737463		Roofing system		1489				
2388-P 1 B		↓ 201737464		↓						
HM ID	Building	Flr.	Rooms	Locations	Material Color	Material	Substrate	Condition	Area Sq. ft or L. ft	Hatch Color
2 4	0.5MG Tank	R	ext	Hatch	Drk Green	P	M	GⓅP	5	
Sample ID		Room Sampled		Sample Location		PIC ID		Notes		
2388-P 2 A		ext 201737465		Hatch		1492				
2388-P 2 B		↓ 201737466		↓						
HM ID	Building	Flr.	Rooms	Locations	Material Color	Material	Substrate	Condition	Area Sq. ft or L. ft	Hatch Color
5	0.5MG Tank	R	BA	handrail, ladder	lt green	P	M	GⓅP	20	
Sample ID		Room Sampled		Sample Location		PIC ID		Notes		
2388-P 3 A		ext 201737467		handrail		1495				
2388-P 3 B		↓ 201737468		ladder						

**Hazardous Homogeneous Materials and Sampling Survey Field Form: Lead Paint**

Project Number: 2388 3 Location: DOW Kekaha 0.5MG Storage Tank Inspector Initials: AI Survey Dates and Times: 8.17.17

HM ID	Building	Flr.	Rooms	Locations	Material Color	Material	Substrate	Condition	Area Sq. ft or L. ft	Hatch Color
6	0.5MG Tank	1	Int	Floor	beige	coating	CC	G F P	5,000	Same as HM7
Sample ID		Room Sampled		Sample Location		PIC ID		Notes		
2388-P 4 A		Int 201737469		floor		1501				
2388-P 4 B		↓ 201737470		↓						
HM ID	Building	Flr.	Rooms	Locations	Material Color	Material	Substrate	Condition	Area Sq. ft or L. ft	Hatch Color
10		1	Ext	walls	gray	P	CC	G F P	10,000	Same as HM10
Sample ID		Room Sampled		Sample Location		PIC ID		Notes		
2388-P 5 A		Ext 201737471		walls		1509				
2388-P 5 B		↓ 201737472		↓						
HM ID	Building	Flr.	Rooms	Locations	Material Color	Material	Substrate	Condition	Area Sq. ft or L. ft	Hatch Color
11		1	Ext	walls	beige	P	CC	G F P	5,000	
Sample ID		Room Sampled		Sample Location		PIC ID		Notes		
2388-P 6 A		Ext 201737473		Walls		1509				
2388-P 6 B		↓ 201737474		↓						



**EMSL Analytical, Inc.**

200 Route 130 North, Cinnaminson, NJ 08077

Phone: (856) 303-2500 Fax: (856) 858-4571 Email: EnvChemistry2@emsl.com

---

Attn:

**Akari Ihara**  
**Myounghee Noh & Associates, LLC**  
**99-1046 Iwaena Street**  
**Suite 210A**  
**Aiea, HI 96701**

9/11/2017

Phone: (808) 484-9214

Fax:

The following analytical report covers the analysis performed on samples submitted to EMSL Analytical, Inc. on 8/23/2017. The results are tabulated on the attached data pages for the following client designated project:

**2388.3**

The reference number for these samples is EMSL Order #011706838. Please use this reference when calling about these samples. If you have any questions, please do not hesitate to contact me at (856) 303-2500.

Approved By:

---

Phillip Worby, Environmental Chemistry  
Laboratory Director



The test results contained within this report meet the requirements of NELAP and/or the specific certification program that is applicable, unless otherwise noted.  
NELAP Certifications: NJ 03036, NY 10872, PA 68-00367, CA ELAP 1877

The samples associated with this report were received in good condition unless otherwise noted. This report relates only to those items tested as received by the laboratory. The QC data associated with the sample results meet the recovery and precision requirements established by the NELAP, unless specifically indicated. All results for soil samples are reported on a dry weight basis, unless otherwise noted. This report may not be reproduced except in full and without written approval by EMSL Analytical, Inc.

**EMSL Analytical, Inc.**

200 Route 130 North, Cinnaminson, NJ 08077  
 Phone/Fax: (856) 303-2500 / (856) 858-4571  
<http://www.EMSL.com> [EnvChemistry2@emsl.com](mailto:EnvChemistry2@emsl.com)

EMSL Order: 011706838  
 CustomerID: 32MYOU50  
 CustomerPO:  
 ProjectID:

Attn: **Akari Ihara**  
**Myounghee Noh & Associates, LLC**  
**99-1046 Iwaena Street**  
**Suite 210A**  
**Aiea, HI 96701**

Phone: (808) 484-9214  
 Fax:  
 Received: 08/23/17 9:15 AM

Project: 2388.3

**Analytical Results**

**Client Sample Description** 2388.PCB1-A,B,C **Collected:** 8/18/2017 **Lab ID:** 011706838-0001

Method	Parameter	Result	RL	Units	Prep Date	Analyst	Analysis Date	Analyst
3540C/8082A	Aroclor-1016	ND	0.79	mg/Kg	9/7/2017	AB	9/11/2017	EH
3540C/8082A	Aroclor-1221	ND	0.79	mg/Kg	9/7/2017	AB	9/11/2017	EH
3540C/8082A	Aroclor-1232	ND	0.79	mg/Kg	9/7/2017	AB	9/11/2017	EH
3540C/8082A	Aroclor-1242	2.3	0.79	mg/Kg	9/7/2017	AB	9/11/2017	EH
3540C/8082A	Aroclor-1248	ND	0.79	mg/Kg	9/7/2017	AB	9/11/2017	EH
3540C/8082A	Aroclor-1254	8.1	0.79	mg/Kg	9/7/2017	AB	9/11/2017	EH
3540C/8082A	Aroclor-1260	18	0.79	mg/Kg	9/7/2017	AB	9/11/2017	EH
3540C/8082A	Aroclor-1262	ND	0.79	mg/Kg	9/7/2017	AB	9/11/2017	EH
3540C/8082A	Aroclor-1268	ND	0.79	mg/Kg	9/7/2017	AB	9/11/2017	EH

**Client Sample Description** 2388.PCB2-A,B,C **Collected:** 8/18/2017 **Lab ID:** 011706838-0002

Method	Parameter	Result	RL	Units	Prep Date	Analyst	Analysis Date	Analyst
3540C/8082A	Aroclor-1016	ND	0.82	mg/Kg	9/7/2017	AB	9/8/2017	EH
3540C/8082A	Aroclor-1221	ND	0.82	mg/Kg	9/7/2017	AB	9/8/2017	EH
3540C/8082A	Aroclor-1232	ND	0.82	mg/Kg	9/7/2017	AB	9/8/2017	EH
3540C/8082A	Aroclor-1242	2.4	0.82	mg/Kg	9/7/2017	AB	9/8/2017	EH
3540C/8082A	Aroclor-1248	ND	0.82	mg/Kg	9/7/2017	AB	9/8/2017	EH
3540C/8082A	Aroclor-1254	3.4	0.82	mg/Kg	9/7/2017	AB	9/8/2017	EH
3540C/8082A	Aroclor-1260	4.7	0.82	mg/Kg	9/7/2017	AB	9/8/2017	EH
3540C/8082A	Aroclor-1262	ND	0.82	mg/Kg	9/7/2017	AB	9/8/2017	EH
3540C/8082A	Aroclor-1268	ND	0.82	mg/Kg	9/7/2017	AB	9/8/2017	EH

**Client Sample Description** 2388.PCB3-A,B,C **Collected:** 8/18/2017 **Lab ID:** 011706838-0003

Method	Parameter	Result	RL	Units	Prep Date	Analyst	Analysis Date	Analyst
3540C/8082A	Aroclor-1016	ND	4.7	mg/Kg	9/7/2017	AB	9/11/2017	EH
3540C/8082A	Aroclor-1221	ND	4.7	mg/Kg	9/7/2017	AB	9/11/2017	EH
3540C/8082A	Aroclor-1232	ND	4.7	mg/Kg	9/7/2017	AB	9/11/2017	EH
3540C/8082A	Aroclor-1242	ND	4.7	mg/Kg	9/7/2017	AB	9/11/2017	EH
3540C/8082A	Aroclor-1248	ND	4.7	mg/Kg	9/7/2017	AB	9/11/2017	EH
3540C/8082A	Aroclor-1254	38	4.7	mg/Kg	9/7/2017	AB	9/11/2017	EH
3540C/8082A	Aroclor-1260	76	4.7	mg/Kg	9/7/2017	AB	9/11/2017	EH
3540C/8082A	Aroclor-1262	ND	4.7	mg/Kg	9/7/2017	AB	9/11/2017	EH
3540C/8082A	Aroclor-1268	ND	4.7	mg/Kg	9/7/2017	AB	9/11/2017	EH





## EMSL Analytical, Inc.

200 Route 130 North, Cinnaminson, NJ 08077

Phone/Fax: (856) 303-2500 / (856) 858-4571

<http://www.EMSL.com>

[EnvChemistry2@emsl.com](mailto:EnvChemistry2@emsl.com)

EMSL Order:	011706838
CustomerID:	32MYOU50
CustomerPO:	
ProjectID:	

### Definitions:

ND - indicates that the analyte was not detected at the reporting limit

RL - Reporting Limit (Analytical)



Asbestos Chain of Custody  
EMSL Order Number (Lab Use Only):

011706838

LATESTING  
520 MISSION STREET  
SOUTH PASADENA, CA 91030  
PHONE: (800)-303-0047  
FAX: (323)-254-9962

Company : Myounghee Noh & Associates L.L.C		EMSL-Bill to: <input type="checkbox"/> Same <input type="checkbox"/> Different If Bill to is Different note instructions in Comments**	
Street: 99-1046 Iwaena St.		Third Party Billing requires written authorization from third party	
City: Aiea	State/Province: Hawaii	Zip/Postal Code:	Country:
Report To (Name): AKari		Telephone #:	
Email Address:		Fax #:	Purchase Order:
Project Name/Number: 2388.3		Please Provide Results: <input type="checkbox"/> Fax <input type="checkbox"/> Email <input type="checkbox"/> Mail	
U.S. State Samples Taken: 4		Connecticut Samples: <input type="checkbox"/> Commercial <input type="checkbox"/> Residential	

Turnaround Time (TAT) Options\* - Please Check

3 Hour  6 Hour  24 Hour  48 Hour  72 Hour  96 Hour  1 Week  2 Week

\*For TEM Air 3 hr through 6 hr, please call ahead to schedule. \*There is a premium charge for 3 Hour TEM AHERA or EPA Level II TAT. You will be asked to sign an authorization form for this service. Analysis completed in accordance with EMSL's Terms and Conditions located in the Analytical Price Guide.

<b>PCM - Air</b> <input type="checkbox"/> Check if samples are from NY <input type="checkbox"/> NIOSH 7400 <input type="checkbox"/> w/ OSHA 8hr. TWA	<b>TEM - Air</b> <input type="checkbox"/> 4-4.5hr TAT (AHERA only) <input type="checkbox"/> AHERA 40 CFR, Part 763 <input type="checkbox"/> NIOSH 7402 <input type="checkbox"/> EPA Level II <input type="checkbox"/> ISO 10312	<b>TEM - Dust</b> <input type="checkbox"/> Microvac - ASTM D 5755 <input type="checkbox"/> Wipe - ASTM D6480 <input type="checkbox"/> Carpet Sonication (EPA 600/J-93/167)
<b>PLM - Bulk (reporting limit)</b> <input type="checkbox"/> PLM EPA 600/R-93/116 (<1%) <input type="checkbox"/> PLM EPA NOB (<1%) Point Count <input type="checkbox"/> 400 (<0.25%) <input type="checkbox"/> 1000 (<0.1%) Point Count w/Gravimetric <input type="checkbox"/> 400 (<0.25%) <input type="checkbox"/> 1000 (<0.1%) <input type="checkbox"/> NYS 198.1 (friable in NY) <input type="checkbox"/> NYS 198.6 NOB (non-friable-NY) <input type="checkbox"/> NIOSH 9002 (<1%)	<b>TEM - Bulk</b> <input type="checkbox"/> TEM EPA NOB <input type="checkbox"/> NYS NOB 198.4 (non-friable-NY) <input type="checkbox"/> Chatfield SOP <input type="checkbox"/> TEM Mass Analysis-EPA 600 sec. 2.5	<b>Soil/Rock/Vermiculite</b> <input type="checkbox"/> PLM CARB 435 - A (0.25% sensitivity) <input type="checkbox"/> PLM CARB 435 - B (0.1% sensitivity) <input type="checkbox"/> TEM CARB 435 - B (0.1% sensitivity) <input type="checkbox"/> TEM CARB 435 - C (0.01% sensitivity) <input type="checkbox"/> TEM Qual. via Filtration Technique <input type="checkbox"/> TEM Qual. via Drop-Mount Technique
<input type="checkbox"/> Check For Positive Stop - Clearly Identify Homogenous Group		<b>Filter Pore Size (Air Samples):</b> <input type="checkbox"/> 0.8µm <input type="checkbox"/> 0.45µm

Samplers Name: AKari Samplers Signature: [Signature]

Comp or separate?  
 (1)  
 (2)  
 (3)

Sample #	Sample Description	Volume/Area (Air) HA # (Bulk)	Date/Time Sampled
2388-PCB1A	Bulk		
↓ ↓ ↓			
2388-PCB3A			
↓ ↓ ↓			

Client Sample # (s): 2388-PCB1A ~ 2388-PCB3C Total # of Samples: 6

Relinquished (Client): [Signature] Date: 8-18-17 Time:

Received (Lab): DF Lores (EMSL FedEx) Date: 8/21/17 Time: 9:20am

Comments/Special Instructions:  
 Rec: FE (EV) 8.22.17 Relinquished: [Signature] 8.22.17

\*After AKari: proceed w/ samples as composite at 3 day TAT on 9/6 14:30

09:15 \*Pasadena Lab sent corresponding samples to supplement for composite analysis on 9/6

011706838

**Hazardous Homogeneous Materials and Sampling Survey Field Form: PCB Bulk**

6.17.17

Project Number: 2388 3 Location: DOW Kekaha 0.5MG Storage Tank Inspector Initials: AI Survey Dates and Times:

HM ID	Building	Fir.	Rooms	Locations	Material Color	Material	Substrate	Condition	Friable ACM Type	Area Sq. ft of L. ft	Hatch Color	Notes
12	0.5 MG Tank	1	Int	Floor + doors Sealant J	Berg	Coating Asphalt Sealant	CC	GFP	Y TSI S M	1000	Same as HMG	
2388-PCB 1 A			Int	Floor + doors		1501						
2388-PCB 1 B						1901						
2388-PCB 1 C												
13	0.5 MG Tank	1	Int	Sealant joint	Berg	Asphalt base sealant	CC	GFP	Y TSI S M	1000	Same HMG	
2388-PCB 2 A						1501						
2388-PCB 2 B												
2388-PCB 2 C												
14	0.5 MG Tank	1	Int	walls	Blk	Coating	CC	GFP	Y TSI S M	1000	Same as HMG	
2388-PCB 3 A			Int	walls		1501						
2388-PCB 3 B												
2388-PCB 3 C												

011706838

**Hazardous Homogeneous Materials and Sampling Survey Field Form: PCB Bulk**

6.17.17

Project Number: 2388 3 Location: DOW Kekaha 0.5MG Storage Tank Inspector Initials: AI Survey Dates and Times:

HM ID	Building	Fir.	Rooms	Locations	Material Color	Material	Substrate	Condition	Friable ACM Type	Area Sq. ft of L. ft	Hatch Color																				
12	0.5 MG Tank	1	Int	floor + drains sealant	Beige	Coating	CC	GFP	Y TSI S M	1000	Same as HMG																				
<table border="1"> <thead> <tr> <th>Sample ID</th> <th>Room Sampled</th> <th>Sample Location</th> <th>PIC ID</th> <th>Notes</th> </tr> </thead> <tbody> <tr> <td>2388-PCB 1 A</td> <td>Int</td> <td>floor + drains</td> <td>1501</td> <td></td> </tr> <tr> <td>2388-PCB 1 B</td> <td>↓</td> <td>↓</td> <td>1501</td> <td></td> </tr> <tr> <td>2388-PCB 1 C</td> <td></td> <td></td> <td></td> <td></td> </tr> </tbody> </table>												Sample ID	Room Sampled	Sample Location	PIC ID	Notes	2388-PCB 1 A	Int	floor + drains	1501		2388-PCB 1 B	↓	↓	1501		2388-PCB 1 C				
Sample ID	Room Sampled	Sample Location	PIC ID	Notes																											
2388-PCB 1 A	Int	floor + drains	1501																												
2388-PCB 1 B	↓	↓	1501																												
2388-PCB 1 C																															
13	0.5 MG Tank	1	Int	sealant joint	Beige	Asphalt long sealant	CC	GFP	Y TSI S M	1000	Same HMG																				
<table border="1"> <thead> <tr> <th>Sample ID</th> <th>Room Sampled</th> <th>Sample Location</th> <th>PIC ID</th> <th>Notes</th> </tr> </thead> <tbody> <tr> <td>2388-PCB 2 A</td> <td></td> <td></td> <td>1501</td> <td></td> </tr> <tr> <td>2388-PCB 2 B</td> <td></td> <td></td> <td></td> <td></td> </tr> <tr> <td>2388-PCB 2 C</td> <td></td> <td></td> <td></td> <td></td> </tr> </tbody> </table>												Sample ID	Room Sampled	Sample Location	PIC ID	Notes	2388-PCB 2 A			1501		2388-PCB 2 B					2388-PCB 2 C				
Sample ID	Room Sampled	Sample Location	PIC ID	Notes																											
2388-PCB 2 A			1501																												
2388-PCB 2 B																															
2388-PCB 2 C																															
14	0.5 MG Tank	1	Int	walls	Blk	Coating	CC	GFP	Y TSI S M	1000	Same as HMG																				
<table border="1"> <thead> <tr> <th>Sample ID</th> <th>Room Sampled</th> <th>Sample Location</th> <th>PIC ID</th> <th>Notes</th> </tr> </thead> <tbody> <tr> <td>2388-PCB 3 A</td> <td>Int</td> <td>walls</td> <td>1501</td> <td></td> </tr> <tr> <td>2388-PCB 3 B</td> <td></td> <td></td> <td></td> <td></td> </tr> <tr> <td>2388-PCB 3 C</td> <td></td> <td></td> <td></td> <td></td> </tr> </tbody> </table>												Sample ID	Room Sampled	Sample Location	PIC ID	Notes	2388-PCB 3 A	Int	walls	1501		2388-PCB 3 B					2388-PCB 3 C				
Sample ID	Room Sampled	Sample Location	PIC ID	Notes																											
2388-PCB 3 A	Int	walls	1501																												
2388-PCB 3 B																															
2388-PCB 3 C																															



**EMSL Analytical, Inc.**

200 Route 130 North, Cinnaminson, NJ 08077

Phone: (856) 303-2500 Fax: (856) 858-4571 Email: EnvChemistry2@emsl.com

---

Attn:

**Akari Ihara**  
**Myounghee Noh & Associates, LLC**  
**99-1046 Iwaena Street**  
**Suite 210A**  
**Aiea, HI 96701**

10/25/2017

Phone: (808) 484-9214

Fax:

The following analytical report covers the analysis performed on samples submitted to EMSL Analytical, Inc. on 10/23/2017. The results are tabulated on the attached data pages for the following client designated project:

**2388-3**

The reference number for these samples is EMSL Order #011708485. Please use this reference when calling about these samples. If you have any questions, please do not hesitate to contact me at (856) 303-2500.

Approved By:

---

Phillip Worby, Environmental Chemistry  
Laboratory Director



The test results contained within this report meet the requirements of NELAP and/or the specific certification program that is applicable, unless otherwise noted.  
NELAP Certifications: NJ 03036, NY 10872, PA 68-00367, CA ELAP 1877

The samples associated with this report were received in good condition unless otherwise noted. This report relates only to those items tested as received by the laboratory. The QC data associated with the sample results meet the recovery and precision requirements established by the NELAP, unless specifically indicated. All results for soil samples are reported on a dry weight basis, unless otherwise noted. This report may not be reproduced except in full and without written approval by EMSL Analytical, Inc.

**EMSL Analytical, Inc.**

200 Route 130 North, Cinnaminson, NJ 08077

Phone/Fax: (856) 303-2500 / (856) 858-4571

<http://www.EMSL.com>[EnvChemistry2@emsl.com](mailto:EnvChemistry2@emsl.com)

EMSL Order:	011708485
CustomerID:	32MYOU50
CustomerPO:	
ProjectID:	

Attn: **Akari Ihara**  
**Myounghee Noh & Associates, LLC**  
**99-1046 Iwaena Street**  
**Suite 210A**  
**Aiea, HI 96701**

Phone: (808) 484-9214  
 Fax:  
 Received: 10/23/17 9:15 AM

Project: 2388-3

**Analytical Results**

**Client Sample Description** 2388-PCB4A **Collected:** 10/19/2017 **Lab ID:** 011708485-0001  
 Interior Coating 0.5 MG Tank

Method	Parameter	Result	RL	Units	Prep Date	Analyst	Analysis Date	Analyst
3540C/8082A	Aroclor-1016	ND	20	mg/Kg	10/24/2017	SD	10/25/2017	EH
3540C/8082A	Aroclor-1221	ND	20	mg/Kg	10/24/2017	SD	10/25/2017	EH
3540C/8082A	Aroclor-1232	ND	20	mg/Kg	10/24/2017	SD	10/25/2017	EH
3540C/8082A	Aroclor-1242	ND	20	mg/Kg	10/24/2017	SD	10/25/2017	EH
3540C/8082A	Aroclor-1248	ND	20	mg/Kg	10/24/2017	SD	10/25/2017	EH
3540C/8082A	Aroclor-1254	73	20	mg/Kg	10/24/2017	SD	10/25/2017	EH
3540C/8082A	Aroclor-1260	210	20	mg/Kg	10/24/2017	SD	10/25/2017	EH
3540C/8082A	Aroclor-1262	ND	20	mg/Kg	10/24/2017	SD	10/25/2017	EH
3540C/8082A	Aroclor-1268	ND	20	mg/Kg	10/24/2017	SD	10/25/2017	EH

**Client Sample Description** 2388-PCB4B **Collected:** 10/19/2017 **Lab ID:** 011708485-0002  
 Interior Coating 0.5 MG Tank

Method	Parameter	Result	RL	Units	Prep Date	Analyst	Analysis Date	Analyst
3540C/8082A	Aroclor-1016	ND	19	mg/Kg	10/24/2017	SD	10/25/2017	EH
3540C/8082A	Aroclor-1221	ND	19	mg/Kg	10/24/2017	SD	10/25/2017	EH
3540C/8082A	Aroclor-1232	ND	19	mg/Kg	10/24/2017	SD	10/25/2017	EH
3540C/8082A	Aroclor-1242	ND	19	mg/Kg	10/24/2017	SD	10/25/2017	EH
3540C/8082A	Aroclor-1248	ND	19	mg/Kg	10/24/2017	SD	10/25/2017	EH
3540C/8082A	Aroclor-1254	51	19	mg/Kg	10/24/2017	SD	10/25/2017	EH
3540C/8082A	Aroclor-1260	170	19	mg/Kg	10/24/2017	SD	10/25/2017	EH
3540C/8082A	Aroclor-1262	ND	19	mg/Kg	10/24/2017	SD	10/25/2017	EH
3540C/8082A	Aroclor-1268	ND	19	mg/Kg	10/24/2017	SD	10/25/2017	EH

**Client Sample Description** 2388-PCB4C **Collected:** 10/19/2017 **Lab ID:** 011708485-0003  
 Interior Coating 0.5 MG Tank

Method	Parameter	Result	RL	Units	Prep Date	Analyst	Analysis Date	Analyst
3540C/8082A	Aroclor-1016	ND	14	mg/Kg	10/24/2017	SD	10/25/2017	EH
3540C/8082A	Aroclor-1221	ND	14	mg/Kg	10/24/2017	SD	10/25/2017	EH
3540C/8082A	Aroclor-1232	ND	14	mg/Kg	10/24/2017	SD	10/25/2017	EH
3540C/8082A	Aroclor-1242	ND	14	mg/Kg	10/24/2017	SD	10/25/2017	EH
3540C/8082A	Aroclor-1248	ND	14	mg/Kg	10/24/2017	SD	10/25/2017	EH
3540C/8082A	Aroclor-1254	39	14	mg/Kg	10/24/2017	SD	10/25/2017	EH
3540C/8082A	Aroclor-1260	170	14	mg/Kg	10/24/2017	SD	10/25/2017	EH
3540C/8082A	Aroclor-1262	ND	14	mg/Kg	10/24/2017	SD	10/25/2017	EH
3540C/8082A	Aroclor-1268	ND	14	mg/Kg	10/24/2017	SD	10/25/2017	EH



## EMSL Analytical, Inc.

200 Route 130 North, Cinnaminson, NJ 08077

Phone/Fax: (856) 303-2500 / (856) 858-4571

<http://www.EMSL.com>

[EnvChemistry2@emsl.com](mailto:EnvChemistry2@emsl.com)

EMSL Order:	011708485
CustomerID:	32MYOU50
CustomerPO:	
ProjectID:	

### Definitions:

ND - indicates that the analyte was not detected at the reporting limit

RL - Reporting Limit (Analytical)



### Asbestos Chain of Custody

EMSL Order Number (Lab Use Only):

011708485

LATESTING  
 520 MISSION STREET  
 SOUTH PASADENA, CA 91030  
 PHONE: (800) 303-0047  
 FAX: (323) 254-9962

RECEIVED  
 CHINA EMSI  
 17 OCT 2017 AM 9:21

Company: Myounghee Noh & Associates L.L.C  
 Street: 99-1046 Iwaena St.  
 City: Aiea State/Province: Hawaii Zip/Postal Code: 96701 Country: U.S.A.  
 Report To (Name): Akari Ihara Telephone #: 808-480-9214  
 Email Address: akari@noh-associates.com Fax #: Purchase Order: 2388.3  
 Project Name/Number: 2388-3 Please Provide Results:  Fax  Email  Mail  
 U.S. State Samples Taken: Hawaii Connecticut Samples:  Commercial  Residential

Turnaround Time (TAT) Options\* - Please Check  
 3 Hour  6 Hour  24 Hour  48 Hour  72 Hour  96 Hour  1 Week  2 Week

\*For TEM Air 3 hr through 6 hr, please call ahead to schedule. \*There is a premium charge for 3 Hour TEM AHERA or EPA Level II TAT. You will be asked to sign an authorization form for this service. Analysis completed in accordance with EMSL's Terms and Conditions located in the Analytical Price Guide.

PCM - Air  Check if samples are from NY  
 NIOSH 7400  w/ OSHA 8hr. TWA  
 PLM - Bulk (reporting limit)  
 PLM EPA 600/R-93/116 (<1%)  
 PLM EPA NOB (<1%)  
 Point Count  
 400 (<0.25%)  1000 (<0.1%)  
 Point Count w/Gravimetric  
 400 (<0.25%)  1000 (<0.1%)  
 NYS 198.1 (friable in NY)  
 NYS 198.6 NOB (non-friable-NY)  
 NIOSH 9002 (<1%)  
 TEM - Air  4-4.5hr TAT (AHERA only)  
 AHERA 40 CFR, Part 763  
 NIOSH 7402  
 EPA Level II  
 ISO 10312  
 TEM - Bulk  
 TEM EPA NOB  
 NYS NOB 198.4 (non-friable-NY)  
 Chatfield SOP  
 TEM Mass Analysis-EPA 600 sec. 2.5  
 TEM - Water: EPA 100.2  
 Fibers >10µm  Waste  Drinking  
 All Fiber Sizes  Waste  Drinking  
 TEM - Dust  
 Microvac - ASTM D 5755  
 Wipe - ASTM D6480  
 Carpet Sonication (EPA 600/J-93/167)  
 Soil/Rock/Vermiculite  
 PLM CARB 435 - A (0.25% sensitivity)  
 PLM CARB 435 - B (0.1% sensitivity)  
 TEM CARB 435 - B (0.1% sensitivity)  
 TEM CARB 435 - C (0.01% sensitivity)  
 TEM Qual. via Filtration Technique  
 TEM Qual. via Drop-Mount Technique  
 Other:  
 PCB Bulk

Check For Positive Stop - Clearly Identify Homogenous Group Filter Pore Size (Air Samples):  0.8µm  0.45µm

Samplers Name: Danny Falanag Samplers Signature: [Signature]

Sample #	Sample Description	Volume/Area (Air) HA # (Bulk)	Date/Time Sampled
① 2388-PCB 4A	Interior coating 0.5 MG Tank	16 bulk	10/19/2017
② 2388-PCB 4B	↓	↓	↓
③ 2388-PCB 4C	↓	↓	↓

Client Sample # (s): 2388-PCB 4A - 4C Total # of Samples: 3

Relinquished (Client): Myounghee Noh Date: 10/19/2017 Time: 12:00

Received (Lab): [Signature] 21.5 Date: 10/23/17 Time: 09:15

Comments/Special Instructions:  
 Separate the black coating material please. Analyze black coating and the remaining bulk material separately. Myounghee Noh 10/19/2017 myounghee@noh-associates.com

\*per client: analyze entire sample

\*Rec'd in plastic (af) [Signature]



---

**SOIL PCB INVESTIGATION FOR  
KEKAHA 0.5 MG CONCRETE STORAGE TANK  
COUNTY OF KAUAI DEPARTMENT OF WATER  
KEKAHA WATER SYSTEM  
KEKAHA, ISLAND OF KAUAI 96752**

**MNA PROJECT 2388\_3**

**AUGUST 22, 2018**



**Myounghee Noh & Associates**

**Environmental Studies and Consulting Services**

200 Kohola Street, Hilo, Hawaii, USA 96720 • 808.935.8727  
99-1046 Iwaena Street, Suite 210A, Aiea, Hawaii, USA 96701 • 808.484.9214

---

SOIL PCB INVESTIGATION FOR  
KEKAHA 0.5 MG CONCRETE STORAGE TANK  
COUNTY OF KAUAI DEPARTMENT OF WATER  
KEKAHA WATER SYSTEM  
KEKAHA, ISLAND OF KAUAI 96752

TMK (4) 1-2-002:039

MNA Project No. 2388\_3

August 22, 2018

Prepared for:

Department of Water  
County of Kauai  
4398 Pua Loke Street  
Lihue, Hawaii 96766

and

KAI Hawaii, Inc.  
50 S. Beretania Street, #C-119C  
Honolulu, Hawaii 96813

Prepared by:

Myounghee Noh & Associates, L.L.C.  
Environmental Studies and Consulting Services  
99-1046 Iwaena Street, Suite 210A, Aiea, HI 96701  
Tel (808) 484-9214  
[www.noh-associates.com](http://www.noh-associates.com)

## TABLE OF CONTENTS

<b>LIST OF ABBREVIATIONS .....</b>	<b>iv</b>
<b>EXECUTIVE SUMMARY .....</b>	<b>v</b>
<b>1.0 INTRODUCTION AND PURPOSE .....</b>	<b>1</b>
<b>2.0 BACKGROUND .....</b>	<b>1</b>
2.1 Site Description.....	1
2.1.1 Climate.....	2
2.1.2 Soils/Geology.....	3
2.1.3 Surface Water.....	3
2.1.4 Groundwater.....	3
2.2 Historic Land Use.....	4
2.3 Current/Future Land Use.....	5
2.4 Investigation History.....	5
<b>3.0 COPC AND CONCEPTUAL SITE MODEL .....</b>	<b>5</b>
3.1 Potential Contamination Sources and COPC.....	5
3.2 Primary Release Mechanism.....	6
3.3 Conceptual Site Model and Exposure Pathway.....	6
3.3.1 Surface Soil.....	6
3.3.2 Subsurface Soil.....	9
3.3.3 Groundwater.....	9
3.3.4 Surface Water.....	9
<b>4.0 SITE INVESTIGATION OBJECTIVES/DATA QUALITY OBJECTIVES.....</b>	<b>9</b>
4.1 Problem Statement.....	9
4.2 Identify Objectives and Chemicals of Potential Concern.....	10
4.3 Define the Boundary of the Study.....	10
4.4 Decision Statements.....	10
<b>5.0 SOIL SAMPLING AND ANALYSIS.....</b>	<b>10</b>
5.1 Selection of Decision Units.....	11
5.1.1 DU1.....	11
5.1.2 DU2.....	11
5.1.3 DU3.....	11
5.1.4 DU4.....	11
5.2 Vegetation Clearance.....	12
5.3 Soil Sampling Activities.....	12
5.3.1 DU1.....	12
5.3.2 DU2.....	13

5.3.3	DU3.....	14
5.3.4	DU4.....	14
5.4	Sample Chain of Custody and Transportation.....	14
5.5	Sample Identification.....	15
5.6	Decontamination Procedures.....	15
5.7	Investigation-Derived Waste.....	15
<b>6.0</b>	<b>ANALYTICAL RESULTS.....</b>	<b>16</b>
6.1	Regulatory Criteria.....	16
6.2	Data Comparison of Field Triplicate Samples.....	16
6.3	PCB Analytical Results.....	19
6.3.1	DU1.....	19
6.3.2	DU2.....	19
6.3.3	DU3.....	19
6.3.4	DU4.....	19
<b>7.0</b>	<b>LABORATORY DATA QUALITY REVIEW.....</b>	<b>20</b>
<b>8.0</b>	<b>SUMMARY OF RESULTS.....</b>	<b>20</b>
<b>9.0</b>	<b>CONCLUSION AND RECOMMENDATIONS.....</b>	<b>20</b>
	<b>REFERENCES.....</b>	<b>22</b>

**TABLES**

Table 1.	Kekaha Aquifer System.....	4
Table 2.	Conceptual Site Model.....	7
Table 3.	Decision Units for PCB Analysis.....	11
Table 4.	PCB Analytical Results.....	18

**APPENDICES**

Appendix A	Figures	
	Figure 1. Site Location Map	
	Figure 2. Topographic Map of Project Site	
	Figure 3A. Decision Units for Surface Soil Sampling	
	Figure 3B. Decision Units for Surface Soil Sampling	
	Figure 4A. DU1 Soil Sampling Locations and Results	
	Figure 4B. DU2 Soil Sampling Locations and Results	
	Figure 4C. DU3 Soil Sampling Locations and Results	
	Figure 4D. DU4 Soil Sampling Locations and Results	
Appendix B	Photographs	
Appendix C	Laboratory Analytical Report	
Appendix D	Tier 1 EAL Surfer Summary Report	

## LIST OF ABBREVIATIONS

bgs	below ground surface
COC	Chain-of-Custody
COPC	Chemical of Potential Concern
CSM	Conceptual Site Model
DL	Detection Limit
DOW	County of Kauai Department of Water
DU	Decision Unit
EAL	Environmental Action Levels
EHE	Environmental Hazard Evaluation
EHMP	Environmental Hazard Management Plan
EPA	Environmental Protection Agency
°F	degrees Fahrenheit
ft	feet
HDOH	State of Hawaii Department of Health
ID	Identification
IDW	Investigation-Derived Waste
kg	kilograms
LCS/LCSD	Laboratory Control Sample/Laboratory Control Sample Duplicate
LOQ	Limit of Quantitation
MCL	Maximum Contaminant Level
µg/L	micrograms per liter
mg/kg	milligrams per kilogram
MG	million gallon
MI	Multi-Incremental
MNA	Myounghee Noh & Associates, L.L.C.
MS/MSD	Matrix Spike/Matrix Spike Duplicate
PCB	Polychlorinated Biphenyls
ppb	parts per billion
PPE	Personal Protection Agency
RSD	Relative Standard Deviation
TMK	Tax Map Key
TSCA	Toxic Substances Control Act
UCL	Upper Confidence Limit
UIC	Underground Injection Control

## EXECUTIVE SUMMARY

Myounghee Noh & Associates, L.L.C. (MNA), was retained by the County of Kauai Department of Water (Project Owner) and KAI Hawaii, Inc. (Prime Architect-Engineer), to conduct a surface soil polychlorinated biphenyls (PCBs) investigation along the Paua drainage ditch, to which water was discharged from a 0.5-million gallon (MG) water storage tank in Paua Valley, Kekaha, Kauai. PCBs were previously discovered in the tank water; the source of PCBs were determined to be the interior liner materials of the tank, based on sampling and analysis of the bulk materials. Previously, the tank was emptied into the drainage ditch adjacent to the tank as needed, to control overflow or to provide access for tank interior inspections and maintenance.

The chemical of potential concern (COPC) for the site is PCB. An important property of PCBs are in their inertness; they resist both acids and alkalis and have thermal stability. This made them useful in a wide variety of applications, including dielectric fluids in electrical equipment and lubricants.

Four decision units (DUs) were established along the Paua drainage ditch from the discharge point/headwall of the tank to approximately 2,500 feet downstream from the discharge point. The DUs were established as the following:

- **DU1:** Encompassed the immediate effluent outlet and extended approximately 12 feet across laterally, as applicable, and went east from the headwall to the drainage ditch, turned toward southwest and downstream; the DU length was approximately 100 feet. A set of triplicate surface soil multi-incremental (MI) samples of 75 increments were collected from DU1 between 0-6 inches below ground surface (bgs). This DU was the closest to the tank where the tank effluent was initially released.
- **DU2:** Encompassed the center of the drainage ditch and extended approximately 12 feet across laterally, as applicable, and included the 100 to 200-ft segment downstream of the headwall, making the DU 100 feet long. A surface MI soil sample of 75 increments was collected from DU2 between 0-6 inches bgs.
- **DU3:** Encompassed the center of the drainage ditch and extended approximately 6 feet across laterally, as applicable, and included the 200 to 500-foot segment downstream of the headwall, making the DU approximately 300 feet long. A surface MI soil sample of 150 increments was collected from DU3 between 0-6 inches bgs.
- **DU4:** Encompassed the center of the drainage ditch and extended approximately 1.5 feet across laterally, as applicable, and included the 500 to 2,500-ft segment downstream of the headwall, making the DU approximately 2,000 feet long. A surface MI soil sample of 150 increments was collected between 0-6 inches bgs.

The analytical results were compared to the State of Hawaii Department of Health (HDOH) Tier 1 Environmental Action Level (EAL) for unrestricted land use of a drinking water source and with surface water closer than 150 meters, 1.2 milligrams per kilogram (mg/kg), and the U.S.

Environmental Protection Agency Toxic Substances Control Act (TSCA) Cleanup Levels for Low Occupancy Areas, 25 mg/kg.

Total PCB was 3.9 mg/kg in the DU1 primary sample, exceeding the Tier 1 EAL of 1.2 mg/kg. The DU1 duplicate and triplicate samples, however, contained 0.95 mg/kg and 0.66 mg/kg, below the EAL. The Relative Standard Deviation (RSD) of the triplicate samples was 97%. Due to this high RSD, the 95% Upper Confidence Level (UCL) for the triplicate set was compared to 150% of the EAL. The 95% UCL was 6.35 mg/kg, exceeding the 150% EAL of 1.8 mg/kg. Based on these findings, the surface soil in DU1 is determined PCB-impacted, exceeding the HDOH Tier 1 EAL. The total PCB concentration, however, was below the TSCA Cleanup Levels for Low Occupancy Areas of 25 mg/kg.

Total PCB concentrations in DU2, DU3, and DU4 soil were 0.12 mg/kg, 0.12 mg/kg, and 0.10 mg/kg, respectively, below the Tier 1 EAL of 1.2 mg/kg.

Due to the rocky site conditions along the ditch, further assessment of DU1 for deeper soil depths is neither feasible nor recommended (Photograph 2 in Appendix B). As the drainage area is mostly rocky, available soils were scarce. During the surface soil sampling, about one half of the sampling points had less than 6-inch depth soils or sediments.

The HDOH Tier 1 PCB soil EAL of 1.2 mg/kg is driven by the direct exposure hazard potential. Direct exposure hazards to human health and environment requires direct contact with contaminated soil. Direct contact can be made by incidental ingestion of soil, dermal contact with soil, and inhalation of soil particles by human and ecological receptors. Access to the drainage ditch is limited by dense vegetation and limited access pathways. Therefore, the direct contact hazard potential at the drainage ditch to on-site workers or trespassers is low. Terrestrial wildlife are expected to ingest surface soil as part of normal feeding activities; therefore, this exposure is considered a potential pathway. However, since the ditch is established with dense vegetative cover, contact with the soil is anticipated to be limited.

Based on the current and future planned use of the site and the lack of available soils, and the PCB levels below the TSCA Cleanup Level of 25 mg/kg, active soil remediation of DU1 is not recommended. Rather, an Environmental Hazard Evaluation (EHE) / Environmental Hazard Management Plan (EHMP) is recommended for long-term management which may include limited or treated impacted-effluent from the existing tank, periodical site inspections, and groundcover monitoring. The EHE must identify specific environmental hazards of PCB. Long-term management under an EHMP is required for site where soil contamination above the levels of potential concern cannot be remediated in a relatively short time frame. The EHMP must include a detailed survey of the PCB-impacted area.

## 1.0 INTRODUCTION AND PURPOSE

Myounghee Noh & Associates, L.L.C. (MNA), under contract with KAI Hawaii, Inc., conducted a soil PCB investigation along a drainage ditch, which receives waters from a 0.5-million gallon (MG) water storage tank in Paua Valley, Kekaha, Kauai. The purpose of the investigation was to evaluate the presence, if any, and levels of polychlorinated biphenyls (PCB) in soil along the Paua drainage ditch, which may have occurred when the PCB-impacted waters from the tank were drained to the ditch.



A View of Paua 0.5-MG Tank (August 2017)

## 2.0 BACKGROUND

### 2.1 Site Description

The County of Kauai Department of Water (DOW) operates the 0.5-MG tank in Paua Valley, Kekaha, Kauai. The Tax Map Key (TMK) of the tank site is (4) 1-2-002:039. The site location is presented in Appendix A, Figures 1 and 2. The tank was built in 1972 and previously serviced nearly 6,000 residents in Kekaha and Waimea. The entire DOW tank site is secured in a fenced area.

In 2017, drinking water samples were collected as part of a tank maintenance project undertaken by the DOW. Measurable levels of PCB were found in the water within the tank. The State of Hawaii Department of Health (HDOH) published that in October 2017, a sample was collected from the surface water layer of the tank and contained 13 parts per billion (ppb) PCB, exceeding federal maximum contaminant level (MCL) of 0.5 ppb. Water collected from the effluent pipe, near the tank floor and leading to the distribution system, contained no measurable levels of PCB. The tank was disconnected from the supply system following the PCB discovery (ehawaii.gov, 2017). Refer to Section 2.4 for additional information.



For the public water distribution, tank water is discharged through the effluent/influent pipe located near the floor of the tank, which connects to the water system. When water removal is necessary, the tank water is discharged into the adjacent drainage ditch. Once the water is discharged to the ditch, the water flows downstream or infiltrates through the soil along the ditch.

Two methods are available to discharge water to the drainage ditch. The first method is through an overflow pipe, which provides a safeguard against overflowing of the tank. The overflow pipe extends from the tank floor to the full depth of the reservoir and has an open-end pipe at the top. If water reaches this height, water flows through the pipe and out of the tank to the drainage ditch, but not into the water distribution system. The second discharge method is through the cleanout drain line that is installed flush with the floor finish. This discharge method is used when the tank needs to be completely emptied for access or maintenance. Water from the tank is infrequently discharged from the tank using either of these methods.



Photographs of the tank discharge pipe/headwall to the drainage ditch (August 2017)



Photographs taken during tank flushing, following an inspection of the tank interior (August 2017)

### 2.1.1 Climate

Kekaha has a tropical climate. The site is located on the dry side of Kauai and receives 33 inches of rain annually (Mink & Lau, 1992). The average temperature is 75°F, with August being the

hottest month averaging 78°F and January being the coolest month with an average of 72°F (Climate-Data, 2017).

### 2.1.2 Soils/Geology

Kauai is the fourth largest and the oldest of the main Hawaiian Islands. It was formed from a single shield volcano that has been highly weathered and eroded to the point that the summit peak can be difficult to locate.

The age of Kauai has transformed much of its surface lava flows into weathered soils lending the island more erosional landforms versus the volcanic landforms found on the younger Hawaiian Islands (Morgan, 1996).

Mink and Lau (1992) describe the geology in the area as the following:

The region is a part of the southwest flank of the original volcano. Napali lavas terminate as a fossil sea cliff along a mile wide coastal plain of terrestrial and marine sediments. The Mana Plain is the most extensive and thickest accumulation of sediments on the island. Inland a few dikes have been mapped.

The United States Department of Agriculture Natural Resources Conservation Service classifies the soil at the tank site as Kekaha extremely stony silty clay loam with 0 to 35 percent slopes. Typically, this soil type is composed of extremely stony silty clay from 0 to 21 inches and clay from 21 to 70 inches. It is well-drained and more than 80 inches from the water table. Soil to the west of the drainage ditch are classified as Waiawa extremely rocky clay with 30 to 80 percent slopes. This soil type is typically composed of clay from 0 to 14 inches, before reaching the bedrock and is well drained (United States Department of Agriculture, 2008).

### 2.1.3 Surface Water

Mink and Lau (1992), describe the hydrogeology in the area as the following:

Having an average rainfall of just 33 inches, Kekaha is the driest Aquifer System in Kauai. Surface drainage is by way of small, non-perennial streams that debouch onto the Mana Plain. The Plain originally was a vast swamp but is not artificially drained to allow cropping.

The tank is located adjacent to a dry streambed which acts as the drainage ditch for the tank. During previous site visits, there were no indications of water flow in the ditch. The stream likely flows during times with heavy rainfall.

### 2.1.4 Groundwater

The HDOH Safe Drinking Water Branch established an Underground Injection Control (UIC) line to serve as a boundary between drinking water and non-drinking water portions of aquifers. Areas

above (mountain side) the UIC line are within drinking water portions of the aquifer, while areas below (ocean side) the UIC line are in non-drinking water portions of the underlying aquifer. The subject property is above the UIC line in a drinking water portion of the aquifer (Hawaii Department of Health Safe Drinking Water Branch, 2017).

The hydraulic gradient, and therefore the expected direction of travel, of the basal groundwater within the basaltic formation is, in general, from mountain areas to the shoreline. According to Mink and Lau (1992), the tank site is located above the Kekaha Aquifer System of the Waimea aquifer sector and described the groundwater as follows:

High-level dike aquifers may occur in Napali lavas in the interior near the Waimea Canyon divide. Otherwise the flank lavas contain basal groundwater. The Napali aquifer beneath the Mana Plain caprock is artesian. This aquifer has been developed as a source of irrigation supply. The sediments are saturated with brackish to salty water. Upward leakage into the sediments from the Napali artesian aquifer is the cause of the original swamp conditions. When artificial drainage for the Plain ceases, it will again become a swamp. Potable water is developed from the wells near Kekaha and Waimea. These wells are located at the inland edge of the Plain.

In 1985, three geotechnical investigation borings were advanced to determine the nature of the soils underlying the 0.5 MG water tank site. A groundwater table was not observed during the drilling down to 30 feet below ground surface (Ernest K. Hirata & Associates, Inc., 1985).

**Table 1. Kekaha Aquifer System**

<b>Aquifer Code</b>	<b>20301112</b>
Island Code	2-Kauai
Aquifer Sector	03-Waimea
Aquifer System	01-Kekaha
Aquifer Type, hydrogeology	1-Basal
Aquifer Condition	1-Unconfined
Aquifer Type, geology	2-Dike, aquifers in dike compartments
<b>Status Code</b>	<b>11111</b>
Development Stage	1-Currently used
Utility	1-Drinking
Salinity (in mg/L Cl <sup>-</sup> )	1-Fresh (<250)
Uniqueness	1-Irreplaceable
Vulnerability to Contamination	1-High

mg/L Cl<sup>-</sup>-milligrams per liter of chloride

## 2.2 Historic Land Use

The site has been used for the water storage for the Kekaha and Waimea areas since 1972 when the tank was built. U.S. Geological Survey topographic maps indicate that the area was historically used as “cropland and pasture” and was likely used by the sugarcane industry (U.S Geological Survey, 2012).

## **2.3 Current/Future Land Use**

The current land use of the site is for water storage tanks that previously serviced the Kekaha and Waimea areas. The future land use will remain the same; no future development at the site is expected.

## **2.4 Investigation History**

On 01 May 2014, DOW conducted water sampling from the tank. The water sample was collected from the floating scum layer. Total PCB as Aroclor 1260 was reported at 0.42 micrograms per liter ( $\mu\text{g/L}$  or ppb), which is below the federal MCL of 0.5  $\mu\text{g/L}$  for PCB, regulated by National Primary Drinking Water Regulation. On 13 September 2017, DOW collected a sample from the surface water of the tank. The 2017 result for total PCB was 24  $\mu\text{g/L}$ , exceeding the MCL. A pesticide Dieldrin was also detected at 0.237  $\mu\text{g/L}$ ; however, there is no MCL established for this discontinued pesticide.

On 17 August 2017, MNA was retained to conduct a building material survey to identify the source of PCB contamination. In preparation of the survey, the tank was emptied by discharging water via pipeline to the drainage ditch. PCB-containing materials were suspected on the interior tank liner materials (i.e. coating materials and sealant). Total PCB concentrations in bulk materials ranged from 10.5 milligrams per kilogram (mg/kg) to 283 mg/kg. The liner materials were observed to be in poor condition. The binding of the material had failed its integrity, indicated by peeling, cracking, or crumbling.

## **3.0 COPC AND CONCEPTUAL SITE MODEL**

### **3.1 Potential Contamination Sources and COPC**

PCBs are the primary chemical of potential concern (COPC) for this investigation. PCBs are mixtures of up to 209 individual chlorinated compounds, known as congeners, and are no longer produced in the U.S., but are still found in the environment. PCBs are a colorless to light yellow oily liquid or solid and were manufactured from 1929 until they were banned in 1979. They were used in hundreds of industrial and commercial applications due to its non-flammability, chemical stability, high boiling point, and electrical insulating properties. Many commercial PCB mixtures are known in the U.S. by the trade name Aroclor (Agency for Toxic Substances and Disease Registry, 2000).

PCBs were previously added to some specialty paints and coatings to improve their performance, primarily for industrial and/or military applications (e.g., paints manufactured to endure thermal stress, vibration or corrosivity). It is possible that these paints or coatings were previously applied in schools or other buildings built or renovated between approximately 1950 and 1979. PCB were added to specialty paints and coatings and may occur in high concentrations (U.S. Environmental Protection Agency, 2015).

PCBs do not readily biodegrade in the environment and thus may persist in the environment for extended periods of time and have the ability to migrate far distances in the air and be dispersed in areas far from where they were released. In water, small amounts may remain dissolved, but most will bind to organic particles and bottom sediments (Agency for Toxic Substances and Disease Registry, 2000).

PCBs in water are transported by diffusion and currents and are removed from the water column by sorption to suspended solids and sediments as well as from volatilization from water surfaces. Higher chlorinated congeners are more likely to sorb, while lower chlorinated congeners are more likely to volatilize. PCBs also leave the water column by concentrating in biota. PCBs in soil are unlikely to migrate to groundwater because of strong binding to soil (Agency for Toxic Substances and Disease Registry, 2000).

PCBs are taken up by small organisms and fish in water, and can bioaccumulate in arthropods, fish, and marine mammals reaching levels that may be thousands of times higher than in water. Terrestrial arthropods and mammals can also take in PCBs. PCBs levels are highest in animals high up in the food chain (Agency for Toxic Substances and Disease Registry, 2000).

### **3.2 Primary Release Mechanism**

The waters from the tank were discharged to the drainage ditch adjacent to the tank, as needed, to control overflow or provide interior tank access. During the hazardous materials survey, PCB-containing materials were identified from the interior coatings of the tank, ranging from 10.5 mg/kg to 283 mg/kg. The coating materials were observed in poor condition; peeling, cracking, or crumbling. DOW Engineering Division conducted water testing for PCB in May 2014 and September 2017. PCB were detected in the range of 0.42 µg/L to 24 µg/L. The ditch area was suspected to be contaminated with PCB due to receiving impacted discharged water or flaked coating materials from the tank.

### **3.3 Conceptual Site Model and Exposure Pathway**

The conceptual site model (CSM) is presented in Table 2. The CSM includes exposure pathway evaluations, potential exposure pathways available for transport of PCB, and their likelihood to reach human and ecological receptors.

#### **3.3.1 Surface Soil**

The tank site is protected by a fence; it is unlikely that on-site workers have accessed the discharge pipe and drainage ditch. Probability for inhalation of contaminated particulate matter and inhalation of PCB is expected to be low because much of the drainage ditch area is heavily vegetated and access to the drainage source is limited.

**Table 2. Conceptual Site Model**

Primary Sources/ Potential COPC	Primary Release Mechanism	Secondary Sources	Potential Environmental Hazards/Exposure Pathway		Hazard present during Construction			Comments
					On-site Worker	Trespasser	Ecological Receptors	
<p><b>PCB- containing water or coating materials from the water tank</b></p> <p><b>COPC: PCB</b></p>	<p>Dischargin g water to the drainage ditch</p>	<p><b>Surface soil (0-6 inches bgs)</b></p>	<p>Risk to Human Health</p>	<p>Direct Exposure</p>	No	No	Yes	<p>Access to the drainage ditch is limited by high vegetation and limited pathways. Therefore, possible direct contact (via ingestion, dermal contact, or inhalation) to on-site workers or trespassers is unlikely.</p> <p>Terrestrial wildlife may incidentally ingest surface soil as part of normal feeding activities; therefore, this exposure is considered a potential pathway.</p>
				<p>Air Transport</p>	Yes	Yes	Yes	<p>The site is surrounded by thick vegetation, preventing the dispersal though surface, however, high wind may carry contaminated soil particles. Lower chlorinated congeners are volatilized.</p>
				<p>Vapor Intrusion into Buildings</p>	No	No	Not applicable	<p>There are no occupied buildings within the project area.</p>
			<p>Stormwater Runoff to Surface Water</p>	No	No	Yes	<p>PCB bind to soil particles and do not move readily to surface water. However, PCB persist in the environment and do not easily biodegrade. PCB have the potential to move from surface soil or be conveyed by runoff to ephemeral surface waters along the drainage ditch and ultimately into marine environment. Exposure pathways for direct contact and ingestion or uptake of PCB in surface water are potential pathways for terrestrial and marine plants and animals.</p>	
			<p>Leaching</p>	No	No	No	<p>PCB bind to soil particles and do not move readily to subsurface soils and groundwater. Terrestrial ecological receptors are not expected to be exposed to subsurface soils and groundwater; therefore, this exposure pathway is considered insignificant.</p>	
			<p>Gross Contamination</p>	Yes	Yes	Yes	<p>There is the potential for gross contamination on surface soil adhering PCB.</p>	

**Table 2. Conceptual Site Model, Cont'd**

Primary Sources/ Potential COPC	Primary Release Mechanism	Secondary Sources	Potential Environmental Hazards/Exposure Pathway		Hazard present during Construction			Comments
					On-site Worker	Trespasser	Ecological Receptors	
<b>PCB- containing water or coating materials from the water tank</b>  <b>COPC: PCB</b>	Dischargin g water to the drainage ditch	<b>Sub surface soil (deeper than 6 inches bgs)</b>	Risk to Human Health	Direct Exposure	No	No	No	PCBs bind to soil particles and do not move readily to subsurface soils and groundwater; therefore, this exposure pathway is considered insignificant.
				Air Transport	No	No	No	
				Vapor Intrusion into Buildings	No	No	Not applicable	
			Stormwater Runoff to Surface Water		No	No	No	
			Leaching		No	No	No	
			Gross Contamination		No	No	No	
<b>PCB- containing water or coating materials from the water tank</b>  <b>COPC: PCB</b>	Dischargin g water to the drainage ditch	<b>Ground- water</b>	Risk to Human Health	Direct Exposure	No	No	Not applicable	PCBs bind to soil particles and do not move readily to subsurface soils and groundwater; therefore, this exposure pathway is considered insignificant.
				Air Transport	No	No	Not applicable	
			Risk to Aquatic Ecological Habitats		Not applicable	Not applicable	No	
			Gross Contamination		No	No	No	

bgs below ground surface  
PCB Polychlorinated Biphenyls

COPC Chemical of Potential Concern

PCBs bind to soil particles and the volatilization rate from soil surfaces is low. However, exposure pathways for incidental ingestion and uptake of PCBs in surface soil are potential pathways for terrestrial plants and animals. Terrestrial herbivorous wildlife and soil invertebrates, may take up PCBs from the surface soil. PCBs also tend to bio-accumulate, therefore, posing a potential exposure pathway.

### 3.3.2 Subsurface Soil

Ecological receptors are not expected to come into contact with subsurface soils because PCBs bind to soil particles and do not migrate readily to subsurface soils. Therefore, this exposure pathway is considered insignificant.

### 3.3.3 Groundwater

Because PCBs generally bind to soil particles and do not leach readily to groundwater, terrestrial ecological receptors are not expected to be exposed to groundwater; therefore, this exposure pathway is considered insignificant.

### 3.3.4 Surface Water

PCBs bind to soil particles and do not leach readily to surface water. However, PCBs do not readily biodegrade but remain in the environment, such as in sediments, and have the potential to migrate from surface soil or be conveyed by runoff to ephemeral surface waters along the drainage ditch and ultimately, into marine environment. Exposure pathways for direct contact and ingestion or uptake of PCBs in surface water are potential pathways for terrestrial and marine plants and animals.

## 4.0 SITE INVESTIGATION OBJECTIVES/DATA QUALITY OBJECTIVES

### 4.1 Problem Statement

In May 2014, DOW conducted water sampling from the top scum water layer. Measurable level of PCBs were reported at 0.42 µg/L, below the federal MCL of 0.5 µg/L. In September 2017, DOW conducted additional water sampling from the tank surface water. PCBs were reported at 24 µg/L, exceeding the MCL.

In August 2017, MNA conducted a building material survey in support of the tank rehabilitation design. PCB-containing tank inner liner was reported, ranging from 10.5 mg/kg to 283 mg/kg. The coating materials were observed in poor conditions.

The waters from the tank were discharged to Paua drainage ditch adjacent to the tank as needed for overflow control or to provide interior tank access. As a result of discharging water from the tank, PCB-impacted water or flaked tank coating materials were likely discharged from the tank into the drainage ditch. Because PCBs tend to bind to soil particles, it was suspected that the drainage ditch soils and sediments may have been impacted.



## **4.2 Identify Objectives and Chemicals of Potential Concern**

The objectives of this soil sampling and analysis is to evaluate the presence of PCB-contaminated soil exceeding the HDOH Tier 1 Environmental Action Levels (EAL) in the drainage ditch. Based on MNA's current understanding of the project site and previous site investigations, described in Sections 3.0, the COPC for this site investigation are PCBs.

## **4.3 Define the Boundary of the Study**

The lateral boundaries of this investigation encompass the drainage ditch from the headwall (effluent point of drainage pipe) of the tank to the intersection of Paua drainage ditch and Kokee Road which is approximately 2,500 feet downstream from the discharge point. PCB leaching to the subsurface soil or groundwater resulting from water discharge from the tank to the drainage ditch is unlikely. Thus, the vertical boundary of the investigation extends from the ground surface to 6 inches below ground surface (bgs) to collect surface soil.

## **4.4 Decision Statements**

The information and data collected, including field observations and sample analytical results, were reviewed and evaluated to determine the presence and levels of PCB-impacted soil. The analytical results were compared to the current HDOH Tier 1 EAL with unrestricted land use above a drinking water resource and located less than 150 meters from surface waters (State of Hawaii Department of Health, Summer 2016, rev. January 2017). The decision statement for this soil sampling and analysis is as follows:

Decision Statement: Has PCB-contaminated water impacted the drainage ditch soil and sediment in concentrations exceeding the HDOH Tier 1 EALs?

- No – No Action if PCB are not detected in soil or if the levels are below the Tier 1 EAL, 1.2 mg/kg.
- Yes – Recommendation for (1) follow-on investigation if the investigation does not provide sufficient information for PCB contamination, or (2) preparation of an Environmental Hazard Evaluation (EHE) / Environmental Hazard Management Plan (EHMP).

## **5.0 SOIL SAMPLING AND ANALYSIS**

Surface soil sampling and analysis were conducted in accordance with the HDOH HEER Office Technical Guidance Manual and implemented the use of multi-incremental (MI) sampling. Four decision units (DUs) were established to address potentially contaminated soil along the drainage ditch which received waters from the 0.5-MG tank. A map depicting each DU and sampling locations is presented in Table 3 and Figures 3A and 3B (Appendix A).

## 5.1 Selection of Decision Units

### 5.1.1 DU1

DU1 encompassed the immediate effluent outlet and extended approximately 12 feet across laterally, went east from the headwall to the drainage ditch, and turned toward southwest and downstream; the DU length was approximately 100 feet. A set of triplicate surface soil MI samples of 75 increments were collected from DU1 between 0-6 inches bgs.

### 5.1.2 DU2

DU2 encompassed the center of the drainage ditch and extended approximately 12 feet across laterally and included the 100 to 200-ft segment downstream of the headwall, making the DU 100 feet long. A surface soil MI sample of 75 increments was collected between 0-6 inches bgs.

### 5.1.3 DU3

DU3 encompassed the center of the drainage ditch and extended approximately 6 feet across laterally sides and included the 200 to 500-ft segment downstream of the headwall, making the DU approximately 300 feet long. A surface soil MI sample of 150 increments was collected between 0-6 inches bgs.

### 5.1.4 DU4

DU4 encompassed the center of the drainage ditch and extended approximately 3 feet across laterally, included the 500 to 2,500-ft segment downstream of the headwall (2,000 feet in length) and ended near Kokee Road. A surface soil MI sample of 150 increments was collected between 0-6 inches bgs.

**Table 3. Decision Units for PCB Analysis**

Sample ID (2388-)	Decision Unit	Location	Rationale	Number of Increments	Sampling Depth (in. bgs)
DU1-MIS1 (primary)	DU1	West to east from headwall to drainage ditch, and downstream. Width was approximately 12 ft wide; length was 100 ft.	Most impacted area where potentially contaminated water would have been released.	75	0-6
DU1-MIS2 (duplicate)				75	0-6
DU1-MIS3 (triplicate)				75	0-6
DU2-MIS1	DU2	100 to 200-foot portion of drainage ditch. Width was approximately 12 ft wide; length was 100 ft.	Projected lower levels of PCBs.	75	0-6
DU3-MIS1	DU3	200 to 500-foot portion of drainage ditch. Width was approximately 12 ft wide; length was 300 ft.	Projected lower levels of PCBs.	150	0-6
DU4-MIS1	DU4	500 to 2,500-foot portion of drainage ditch to nearby Kokee Rd. Width was approximately 3 ft wide; length was 2,000 ft.	Projected lowest levels of PCBs.	150	0-6

bgs	below ground surface	MIS	Multi-Increment Sample
ID	Identification	PCB	Polychlorinated Biphenyls

The collected MI samples were analyzed for PCB using the U.S. Environmental Protection Agency (EPA) Method 8082. A description of each DU and sampling locations is presented in Table 3 and Figures 3A and 3B (Appendix A).

## 5.2 Vegetation Clearance

MNA attempted soil sample collection on 04 June 2018. However, the drainage ditch was overgrown with dense vegetation making access to the ditch difficult. During 05-22 June 2018, DOW conducted vegetation clearance of approximately 2,500 feet along the drainage ditch, 12 feet wide for DU1 through DU3, and 3 feet wide along DU4. Following vegetation clearance of the drainage ditch by the DOW, soil sampling was conducted from 27-28 June 2018.

## 5.3 Soil Sampling Activities

MNA collected soil samples using the MI sampling method. Samples were analyzed for PCB by EPA Method 8082A. Photographs of the field sampling activities are presented in Appendix B.

### 5.3.1 DU1

DU1 encompassed the width of the drainage ditch and ran west to east from the headwall to the drainage ditch, turned to the southwest, and ran downstream; it was approximately 100 feet in length. On 27 June 2018, a primary, duplicate, and triplicate MI samples were collected from the DU. Entire continuous soil core plugs were collected using a hammer-head soil probe ( $\frac{7}{8}$ -in diameter) from 75 independent increment locations/per MI sample within the DU. A grid containing seventy-five 4-ft by 4-ft cells was established to determine increment sampling locations. The DU grid was three cells (12 ft) wide and 25 cells (100 ft) long. Three increments, one increment per triplicate sample, were collected from each 4-ft by 4-ft cell. Duplicate increment samples were collected generally 1 ft to the east of each primary increment sampling location; triplicate samples were collected generally 1 ft to the south from each primary increment sampling location. Figure 4A depicts the grid pattern and increment locations.

The planned sampling depth was 0-6 inches bgs; however, the surface of DU was covered with vegetation, boulders, and rocks and as a result, surface soil was scarce. Sampler refusal was encountered between 3 to 6 inches bgs in about one half of the 75 cells. When sampler refusal was encountered before reaching 6 inches bgs, soil samples were collected from surface to the refusal depth.

The entire soil plug between 0-6 inches, depending on the depth of refusal, was collected from 75 locations for the bulk MI sample. Each soil plug (increment) weighted 30-50 grams, depending on refusal depth, and was combined in the field to create a bulk MI sample, which had a final weighed mass of 2.5 kilograms (kg). The MI sample was then transferred into a 1-gallon plastic

sealable bag, sealed, double-bagged, labeled, and placed in a chilled insulated chest prior to transfer to MNA's Aiea office via cargo.

A set of triplicate surface soil MI sample of 75 increments was collected from DU1 using the same sampling procedures. The following steps were taken to collect the primary, duplicate, and triplicate samples (Figure 3A).

- *Step 1.* Incremental primary soil sampling: The soil increments for the primary sample were collected at the 75 cells. Within each cell, the soil collection was biased toward most abundant soil spot. The final weighed sample mass was 2.5 kg.
- *Step 2.* Incremental duplicate soil sampling: Once the incremental primary soil sampling was completed and the sample weighed, the duplicate soil increments were collected from approximately 1 foot east of the primary increment locations. A few attempts were made to locate available soil or sediment pockets. The final weighed sample mass was 2.9 kg.
- *Step 3.* Incremental triplicate soil sampling: Once the duplicate soil sampling was completed and the sample weighed, the triplicate soil increments were collected approximately 1 ft south of the primary increment locations. A few attempts were made to locate available soil or sediment pockets. The final weighed sample mass was 2.5 kg.

The planned sampling depth was 0-6 inches bgs; however, the sampling depth of each increment varied between to 3 to 6 inches depending on refusal depth. The sampling locations were adjusted based on accessible sampling depth, with two to three times of sampling/boring attempts per increment collected.

### 5.3.2 DU2

DU2 encompassed the width of the drainage ditch, approximately 12 feet wide, and was 100 ft to 200 ft downstream of the headwall, making it 100 ft in length. On 27 June 2018, an MI sample was collected from the DU. Entire continuous soil core plugs were collected using a hammer-head soil probe from 75 independent increment locations within the DU. A grid containing seventy-five 4-ft by 4-ft cells was established to determine increment sampling locations. The DU grid was three cells (12 feet) wide and 25 cells (100 ft) long. One increment was collected from each 4-ft by 4-ft cell. Figure 4B presents the DU dimensions and sampling grid used to determine sampling increment locations.

The planned sampling depth was 0-6 inches bgs, however, sampler refusal was encountered between 3 to 6 inches from about one half of 75 grid cells due to presence of boulders, and rocks. When sampler refusal was encountered before reaching 6 inches bgs, soil samples were collected from surface to the refusal depth. The entire soil plug between 0-6 inches depending on the refusal was collected from 75 locations for the bulk MI sample. Each soil plug (increment) weighed 30-50 grams, depending on refusal depth, and was combined in the field to create a bulk MI sample, which had a final weighed mass of 3.3 kg. The MI sample was transferred into a 1-gallon plastic sealable bag, sealed, double-bagged, labeled, and placed in a chilled insulated chest prior to transfer to MNA's Aiea office via cargo.

### 5.3.3 DU3

DU3 encompassed the width of the drainage ditch, approximately 12 feet wide, and was 200 ft to 500 ft from the headwall, making it 300 ft in length. On 27 June 2018, an MI sample was collected from the DU. Entire continuous soil core plugs were collected using a hammer-head soil probe from 150 independent increment locations within the DU. A grid containing one hundred fifty 4-ft by 6-ft cells was established, three cells (12 ft) wide and 50 cells (300 ft) long. One increment was collected from each 4 ft by 6 ft cell. Figure 4C presents the DU dimensions and sampling grid used to determine sampling increment locations.

The planned sampling depth was 0-6 inches bgs; however, sampler refusal was encountered between 3 to 6 inches from about one half of 150 sampling locations due to presence of boulder and rocks. When sampler refusal was encountered before reaching 6 inches bgs, soil samples were collected from surface to the refusal depth. The entire soil plug between 0-6 inches depending on the refusal was collected from 150 locations for the bulk MI sample. Each soil plug (increment) weighed 30-50 grams, depending on refusal depth, and was combined in the field to create a bulk MI sample, which had a final weighed mass of 6.6 kg. The MI sample was transferred into a 2-gallon plastic sealable bag, sealed, double-bagged, labeled, and placed in a chilled insulated chest prior to transfer to MNA's Aiea office via cargo.

### 5.3.4 DU4

DU4 encompassed the width of the drainage ditch, approximately 3 feet wide, and was 500 ft to 2,500 ft from the headwall, making it 2,000 ft in length. On 27 June 2018, an MI sample was collected from the DU. Entire continuous soil core plugs were collected using a hammer-head soil probe from 150 independent increment locations within the DU. A grid containing one hundred fifty 3-ft by 13-ft cells was established to determine increment sampling locations. The grid was one cell (3 ft) wide and 150 cells (approximately 2,000 ft) long. One increment was collected from each 3-ft by 13-ft cell. Figure 4D presents the DU dimensions and sampling grid.

The planned sampling depth was 0-6 inches bgs, however, sampler refusal continued between 3 to 6 inches from about one half of 150 sampling locations due to presence of boulder and rocks. When sampler refusal was encountered before reaching 6 inches bgs, soil samples were collected from surface to the refusal depth. The entire soil plug between 0-6 inches depending on the refusal was collected from 150 locations for the bulk MI sample. Each soil plug (increment) weighed 30-50 grams, depending on refusal depth, and was combined in the field to create a bulk MI sample, which had a final weighed mass of 6.6 kg. The MI sample was transferred into a 2-gallon plastic sealable bag, sealed, double-bagged, labeled, and placed in a chilled insulated chest prior to transfer to MNA's Aiea office via cargo.

## 5.4 Sample Chain of Custody and Transportation

Samples collected for analysis were recorded in the field logbook and chain-of-custody (COC) form. Following collections during 27-28 June 2018, the samples were placed in a cooler and

chilled to 2-4°C with wet ice. On 29 June 2018, one cooler was transferred via inter-island cargo with frozen blue ice to MNA's Aiea office where samples were refrigerated. The samples were transported in two coolers on 02 July 2018 to TestAmerica Laboratories, Inc., in West Sacramento, California, via overnight airfreight.

The COC served as an analytical request form and as a place to record sample condition upon receipt. Two coolers containing samples were accompanied by identical COCs, identifying the contents of the cooler. Custody seals were signed and dated and then placed over each cooler and each sample container to detect potential tampering.

## 5.5 Sample Identification

Each field sample collected was assigned a sample identification (ID) which ensures uniqueness and clarity. Each sample ID was used to indicate the sample location and MIS sampling number using the following components:

2388-DU<sub>x</sub>-MIS<sub>y</sub>

where, DU<sub>x</sub>: Sampling location (i.e. DU1: from headwall and 100 feet downstream)

MIS<sub>y</sub>: Sample number (i.e. MIS1 for primary, MIS2 for duplicate, MIS3 for triplicate)

For example, 2388-DU1-MIS1 was the sample ID used for the primary soil sample collected from DU1.

## 5.6 Decontamination Procedures

Personnel handling samples donned new nitrile gloves prior to each sampling. The sampling equipment requiring decontamination was a manual hammer-head soil probe sampler. The manual sampler was decontaminated between DUs as follows: (1) washed with a non-phosphate detergent Liquinox and potable water solution; (2) rinsed with potable water; and (3) sprayed with distilled water.

## 5.7 Investigation-Derived Waste

Investigation-derived waste (IDW) for the site investigation was limited to decontamination rinsate generated from decontaminating the non-disposable equipment; personal protective equipment (PPE), such as nitrile gloves; and disposable sampling equipment.

Less than 5 gallons of decontamination water was generated. The decontamination water was spread on site not to result in surface runoff. Disposable PPE and sampling equipment was collected in plastic trash bags, double bagged, and disposed of as solid waste.

## 6.0 ANALYTICAL RESULTS

### 6.1 Regulatory Criteria

Soil analytical results were compared to the HDOH Tier 1 EAL, 1.2 mg/kg, for unrestricted land use above a drinking water resource and located less than 150 meters to surface water. In addition, the results were also compared to the Toxic Substances Control Act (TSCA) Cleanup Level because the investigation, cleanup, verification and disposal of soil contaminated with PCB is regulated under 40 CFR 761.61 (PCB remediation waste) of the TSCA.

Under TSCA, remediation sites fall into two categories: low-occupancy areas and high-occupancy areas. In terms of frequency of occupation, a low-occupancy area limits occupancy for any individual who is not wearing dermal and respiratory protection to less than 335 hours per calendar year for porous surfaces (i.e. soil, concrete).

Examples of low-occupancy area are an electrical substation where a worker spends small amounts of time per week, an unoccupied area outside a building, an electrical equipment vault, or in the non-office space in a warehouse where occupancy is transitory. High occupancy is defined as areas where occupancy for any individual who is not wearing dermal and respiratory protection exceeds the time limits specified for low occupancy. Examples of high occupancy area are: a residence, school, day care center, sleeping quarters, a single or multiple occupancy 40 hours per week work station, a school classroom, a cafeteria in an industrial facility, a control room, or a work station at an assembly line.

For this soil investigation, the cleanup criteria for low-occupancy areas, 25 mg/kg, was used. The summary of laboratory analytical results is presented in Table 4, and the laboratory analytical report is provided in Appendix C. A summary report of the PCB EAL is provided in Appendix D, which includes a breakdown of the action levels by environmental hazard.

### 6.2 Data Comparison of Field Triplicate Samples

MNA collected a set of triplicate surface soil samples from DU1 to support the reproducibility of the field sampling technique and analytical practice and representativeness of the soil investigation. Field performance was reviewed by comparing the results of primary, duplicate, and triplicate samples of DU1. Standard deviation, average, and/or the percent relative standard deviation (RSD) between triplicates. The RSD was calculated using the following equation.

$$RSD (\%) = \frac{\text{Replicate Standard Deviation}}{\text{Replicate Mean}} \times 100\%$$

The 95% upper confidence level (UCL) of the average was calculated using the Chebyshev method for comparison to the EAL using the following equation. The 95% UCL of the average is defined as a value that, when repeatedly calculated for randomly drawn subsets of size “r” from a population, equals or exceeds the population arithmetic mean 95% of the time.

$$95\% \text{ UCL} = \text{average} + \left( \sqrt{\frac{1}{\alpha}} - 1 \times \frac{SD}{\sqrt{r}} \right)$$

Where: SD = Standard deviation; r = number of replicate samples;  
 $\alpha$  = acceptable level of potential decision error (0.05 for a 95% UCL);  
t = (1- $\alpha$ )<sup>th</sup> quantile of the Student's t-distribution with (r-1) degrees of freedom

Table 4 presents the average, standard deviation, and RSD between the triplicate samples that were collected from DU 1.

**RSD:** If the RSD between field triplicate samples is 35% or less, the total error is considered within a reasonable range for precision and reproducibility for field sampling activities. The percent RSD of the set of DU1 triplicate was 97%, indicating lower precision and confidence in the replicate data. This high RSD may have resulted from rocky site conditions and uneven soil availability of the DU.

As discussed in Section 5.3.1, the surface of DU was covered with dense vegetation, boulders, and rocks and, as a result, surface soil was scarce. During sample collection, MNA searched for soil pockets found between boulders and rocks. Additionally, the sampling depth of each increment varied due to sample refusal encountered between 0-6 inches bgs. The sampling locations and depths were adjusted based on soil accessibility. Approximately two to three samplings/borings were attempted per each increment of soil collected. These inconsistent soil availability/depths and the natural rocky conditions of DU1 accounted for the high RSD and poor precision.

**95% UCL:** Because the RSD was 97%, the 95% UCLs for the samples were calculated and estimated as presented in Table 4 in accordance with Section 4.2.7.3 Evaluation of Data Representativeness of the HDOH TGM, in order to compare the 95% UCL values to 150% of the PCB EAL, 1.8 mg/kg. This approach helps to ensure that potentially significant risk to human health and the environment is not inadvertently overlooked under a worst-case scenario, in the case that the true mean actually does exceed the action level (Hawaii Department of Health Office of Hazard Evaluation and Emergency Reponse, 2008).



**Table 4. PCB Analytical Results**

Sampling Locations/ Sample ID  Analytes	Analytical Results (mg/kg)											Regulatory Criteria (mg/kg)				
	DU1			DU2		DU3		DU4		HDOH EAL	150% HDOH EAL	TSCA Cleanup Standards for Low Occupancy				
	DU1-MIS1 (Primary)	DU1-MIS2 (Duplicate)	DU1-MIS3 (Triplicate)	DU2-MIS1	DU3-MIS1	DU4-MIS1										
PCB-1016	0.1	U M J1	0.049	U M	0.02	U M	0.0099	U M	0.01	U M	0.01	U	N/A	N/A	N/A	
PCB-1221	0.15	U	0.074	U	0.03	U	0.015	U M	0.015	U	0.015	U	N/A	N/A	N/A	
PCB-1232	0.2	U M	0.099	U M	0.04	U M	0.02	U M	0.02	U M	0.021	U	N/A	N/A	N/A	
PCB-1242	0.2	U M	0.099	U M	0.04	U M	0.02	U M	0.02	U M	0.021	U	N/A	N/A	N/A	
PCB-1248	0.15	U M	0.074	U M	0.03	U M	0.015	U M	0.015	U M	0.015	U M	N/A	N/A	N/A	
PCB-1254	0.1	U M	0.049	U M	0.02	U M	0.0099	U M	0.01	U M	0.01	U M	N/A	N/A	N/A	
PCB-1260	3	D J1	0.51	D	0.48	D	0.032	J	0.025	J	0.0045	J	N/A	N/A	N/A	
<b>Total PCB</b>	<b>3.90</b>		<b>0.95</b>		<b>0.66</b>		<b>0.12</b>		<b>0.12</b>		<b>0.10</b>		<b>1.2</b>	N/A	<b>25</b>	
<b>95% UCL</b>			<b>6.35</b>				<b>0.53</b>		<b>0.53</b>		<b>0.45</b>		N/A	<b>1.8</b>	N/A	
Data Precision Review of Triplicate Samples	Mean: 1.84 mg/kg Standard Deviation: 1.79 Relative Standard Deviation (RSD): 97%						N/A	N/A	N/A	N/A	N/A	N/A	N/A	N/A	N/A	N/A

**Bold values indicate levels above the laboratory limit of quantitation. Red values indicate levels above regulatory standards.**

**Regulatory Criteria:**

HDOH EAL: HDOH Tier 1 Environmental Action Levels (EAL) for unrestricted land use of a drinking water source and located less than 150 meters from surface water.

150% HDOH EAL. Per Section 4.2.7.3 of HDOH TGM, 95% UCL were compared to 150% of HDOH EAL.

TSCA Cleanup Standard for Low Occupancy: 25 mg/kg in residual waste or porous surface, unless otherwise specified in 40 CFR 761.61(a)(4)(i)(B) & institutional control implemented (deed restriction). Deed restriction will be required if PCB concentration are greater than 25 mg/kg.

**Laboratory Analytical Data Qualifiers:**

- J1 Estimated: The quantitation is an estimation due to discrepancies in meeting certain analyte-specific quality control criteria.
- M Manual integrated compound.
- U Undetected at the Limit of Detection.
- D The reported value is from a dilution.
- J Estimated: The analyte was positively identified; the quantitation is an estimation

**Acronyms/Abbreviations:**

- 95% UCL 95% Upper Confidence Limit mg/kg milligrams per kilogram
- HDOH EAL State of Hawaii Department of Health Environmental Action Level PCB Polychlorinated Biphenyls
- ID identifier TSCA Toxic Substances Control Act
- N/A Not Applicable or Not Available

**Note**

- 1) 95% UCL: Compare the 95% Upper Confidence Level for replicate data to 150% of the EAL for decision making per Section 4.2.7.3 of HDOH TGM.

## 6.3 PCB Analytical Results

### 6.3.1 DU1

PCB-1260 was measured in the primary sample at 3 milligrams per kilogram (mg/kg). PCB-1016, -1221, -1232, -1242, -1248, and -1254 were also measured, but below the limit of quantitation (LOQ) ranging from 0.1 mg/kg to 0.2 mg/kg. Total PCB was calculated as 3.90 mg/kg, exceeding the HDOH Tier 1 EAL of 1.2 mg/kg, but below the TSCA cleanup level for low-occupancy areas of 25 mg/kg.

The duplicate sample had a measureable level of PCB-1260 of 0.51 mg/kg. Other PCB Arochlor mixtures were measured, but below the LOQ, ranging from 0.049 mg/kg to 0.099 mg/kg. Total PCB was calculated at 0.95 mg/kg, below the EAL of 1.2 mg/kg.

The triplicate sample had a measureable level of PCB-1260 at 0.48 mg/kg. Other PCB Arochlor mixtures were measured but below the LOQ, ranging from 0.02 mg/kg to 0.04 mg/kg. Total PCB was calculated as 0.66 mg/kg, below the EAL of 1.2 mg/kg.

The data comparison between triplicate samples is presented in Table 4. The RSD for total PCB was 97%. Because the RSD was between 50% and 100%, the 95% UCL was compared to 150% of the Tier 1 EAL, 1.8 mg/kg. The 95% UCL was calculated as 6.35 mg/kg, exceeding the 150% EAL of 1.8 mg/kg, but below the TSCA Cleanup Level of 25 mg/kg.

### 6.3.2 DU2

PCB-1260 was measured in the sample at 0.032 mg/kg. PCB-1016, -1221, -1232, -1242, -1248, and -1254 were also measured from 0.0099 mg/kg to 0.2 mg/kg. Total PCB was calculated as 0.12 mg/kg, one tenth of the HDOH Tier 1 EAL of 1.2 mg/kg. The 95% UCL of DU2 was calculated as 0.53 mg/kg, below the 150% EAL of 1.8 mg/kg.

### 6.3.3 DU3

PCB-1260 was measured in the sample at 0.025 mg/kg. PCB-1016, -1221, -1232, -1242, -1248, and -1254 were also measured, ranging from 0.01 mg/kg to 0.2 mg/kg. Total PCB was calculated as 0.12 mg/kg, one tenth of the HDOH Tier 1 EAL of 1.2 mg/kg. The 95% UCL of DU3 was calculated as 0.53 mg/kg, below the 150% EAL of 1.8 mg/kg.

### 6.3.4 DU4

PCB-1260 was measured in the sample at 0.0045 mg/kg. PCB-1016, -1221, -1232, -1242, -1248, and -1254 were also measured, ranging from 0.01 mg/kg to 0.21 mg/kg. Total PCB was calculated as 0.10 mg/kg, less than one tenth of the HDOH Tier 1 EAL of 1.2 mg/kg. The 95% UCL of DU3 was calculated as 0.45 mg/kg, below the 150% EAL of 1.8 mg/kg.

## **7.0 LABORATORY DATA QUALITY REVIEW**

MNA conducted a review of analytical data quality to determine the usability of the data generated by performing a data check for sample preservation methods, technical sample holding times, method blanks, laboratory control sample/laboratory control sample duplicate (LCS/LCSD), matrix spike/matrix spike duplicate (MS/MSD), and surrogate recoveries.

The technical holding time was met. All samples were labeled and recorded in a COC document. No PCB were detected in the laboratory blank sample, which indicated that the analytical processes were free of the contaminant. The LCS/LCSD, MS/MSD, and surrogate recoveries were within the laboratory acceptable ranges. All reporting limits were below the Tier 1 EAL for unrestricted land use. No anomalies were reported by the laboratory, although samples collected from DU1 Required dilutions. Based on review of the laboratory data quality information, all analytical data was considered valid and usable.

## **8.0 SUMMARY OF RESULTS**

Total PCB calculations for the primary sample from DU1 was 3.90 mg/kg, above the Tier I EAL for unrestricted land use of 1.2 mg/kg, but below the TSCA Cleanup Standard of 25 mg/kg for Low Occupancy Areas. Total PCB for the duplicate and triplicate samples from DU1 were 0.95 mg/kg and 0.66 mg/kg, respectively, with both results below the Tier 1 EAL and TSCA Cleanup Standard. The RSD of the triplicate samples was calculated at 97%. Due to the high RSD, the 95% UCL was compared to the 150% EAL for PCB, which was determined to be 1.8 mg/kg. The 95% UCL for the triplicate was 6.35 mg/kg, above the 150% PCB EAL of 1.8 kg/kg. Based on these results, the PCB concentrations within DU1 exceeds the HDOH EAL. The inconsistent soil availability/depths and the natural rocky conditions of DU1 accounted for the high RSD and poor precision. PCB in water or released flaked tank coating materials may have been unevenly distributed within the DU.

The total PCB for DU2 was 0.12 mg/kg, one tenth of the Tier 1 EAL of 1.2 mg/kg. The 95% UCL was calculated at 0.53 mg/kg, below the 150% PCB EAL of 1.8 mg/kg.

The total PCB for DU3 was 0.12 mg/kg, one tenth of the Tier 1 EAL of 1.2 mg/kg. The 95% UCL was calculated at 0.53 mg/kg, below the 150% PCB EAL of 1.8 mg/kg.

The total PCB for DU4 was 0.10 mg/kg, less than one tenth of the Tier 1 EAL of 1.2 mg/kg. The 95% UCL was calculated at 0.45 mg/kg, below the 150% PCB EAL of 1.8 mg/kg.

## **9.0 CONCLUSION AND RECOMMENDATIONS**

Measurable levels of PCB in the Kekaha 0.5-MG tank water were previously reported; the source of PCB was determined to be the interior liner materials of the tank, based on bulk materials sampling and analysis. The objective of this soil investigation was to evaluate the presence and levels of PCB-contaminated soil in the drainage ditch, which received effluent from the Kekaha 0.5-MG water storage tank in Paua Valley.

DU1. The surface soil (0-6 inches bgs) in DU1, which started from the discharge pipe to 100 feet down the drainage ditch, is found to be PCB-impacted, exceeding the HDOH Tier 1 EAL of 1.2 mg/kg, but below the TSCA Cleanup Standard of 25 mg/kg. Further delineation to assess the deeper soil depths is not feasible due to the lack of available soil, as the area was mostly rock. During the surface soil sampling, soil depths down to 6 inches were not observed at about one half of the sampled areas.

DU2, DU3, DU4. None of the surface soils in DU2, DU3, and DU4, are determined to be PCB-impacted above the Tier 1 EAL. As a result, it is unlikely that PCB-impacted soil exceeding the EAL is present outside of DU1 surface soil.

The HDOH Tier 1 PCB soil EAL of 1.2 mg/kg is driven by the direct exposure hazard. Direct exposure hazards to human health and environment involves direct contact with contaminated soil. Direct contact can be made by incidental ingestion of soil, dermal contact with soil, and inhalation of soil particles by human and ecological receptors. Access to the drainage ditch is limited by dense vegetation and limited access pathways. Therefore, the direct contact hazard at the drainage ditch to on-site workers or trespassers is unlikely. Terrestrial wildlife are expected to ingest surface soil as part of normal feeding activities; therefore, this exposure is considered a potential pathway. However, since the drainage ditch is dense with vegetative cover, contact to the soil is limited.

Based on the current and future planned use of the site and lack of available soils in DU1, and the findings of total PCB below the TSCA Cleanup Level of 25 mg/kg, active soil remediation of DU1 may not be necessary or feasible. Rather, an EHE / EHMP is recommended to control the residual PCBs in DU1 soil for long-term management which may include limited or treated impacted-effluent from the existing tank, periodical site inspections, and ground cover monitoring. The EHE must identify specific environmental hazards. Long-term management under an EHMP is required for site where soil contamination above the levels of potential concern cannot be remediated in a relatively short time frame. The EHMP must include a detailed survey of the PCB-impacted area.

## REFERENCES

- Agency for Toxic Substances and Disease Registry. (2000, November). *Toxicological Profile for Polychlorinated Biphenyls (PCBs)*. Retrieved from Agency for Toxic Substances and Disease Registry: <https://www.atsdr.cdc.gov/toxprofiles/tp.asp?id=142&tid=26>
- Climate-Data. (2017, December 13). *Climate: Kekaha*. Retrieved from Climate-Data.Org: <https://en.climate-data.org/location/766106/>
- ehawaii.gov. (2017, December 4). *Governor of the State of Hawaii*. Retrieved from DOH News Release: Organic Chemical Round in Kauai Water Tank: <https://governor.hawaii.gov/newsroom/latest-news/doh-news-release-organic-chemical-found-in-kauai-water-tank/>
- Ernest K. Hirata & Associates, Inc. (1985). *Foundation Investigation 0.5 MG Water Tank, Paua Valley, Kekaha, Kauai, Hawaii*.
- Hawaii Department of Health Office of Hazard Evaluation and Emergency Response. (2008). *Technical Guidance Manual for the Implementation of the Hawai'i State Contingency Plan*. Honolulu: Hawaii Department of Health Office of Hazard Evaluation and Emergency Response.
- Hawaii Department of Health Safe Drinking Water Branch. (2017, August 11). *UIC Map of Kauai*. Retrieved from Underground Injection Control (UIC) Program: <http://health.hawaii.gov/sdwb/underground-injection-control-program/>
- Mink, J. F., & Lau, L. S. (1992). *Aquifer Identification and Classification for Kauai: Groundwater Protection Strategy for Hawai'i*. Honolulu: University of Hawaii, Water Resources Research Center.
- Morgan, J. R. (1996). *Hawai'i, A Unique Geography*. Honolulu: Bess Press.
- State of Hawaii Department of Health. (Summer 2016, rev. January 2017). *Evaluation of Environmental Hazards at Sites with Contaminated Soil and Groundwater*. Retrieved from <http://hawaii.gov/health/environmental/hazard/index.html>
- U. S. Environmental Protection Agency. (2005). *Polychlorinated Biphenyl (PCB) Site Revitalization Guidance Under the Toxic Substances Control Act (TSCA)*. U. S. Environmental Protection Agency.
- U.S Geological Survey. (2012, February 10). *USGS*. Retrieved from Land Use and Land Cover, 1976-98, Kauai County, Hawaii: <https://pubs.er.usgs.gov/publication/1128>
- U.S. Environmental Protection Agency. (2015). *PCBs in Building Materials—Questions & Answers*. Retrieved from [https://www.epa.gov/sites/production/files/2016-03/documents/pcbs\\_in\\_building\\_materials\\_questions\\_and\\_answers.pdf](https://www.epa.gov/sites/production/files/2016-03/documents/pcbs_in_building_materials_questions_and_answers.pdf)
- United States Department of Agriculture. (2008, November 13). *Natural Resources Conservation Service*. Retrieved from Web Soil Survey: <http://websoilsurvey.nrcs.usda.gov/app/HomePage.htm>

## **APPENDIX A. FIGURES**

Figure 1. Site Location Map

Figure 2. Topographic Map of Project Site

Figure 3A. Decision Units for Surface Soil Sampling

Figure 3B. Decision Units for Surface Soil Sampling

Figure 4A. DU1 Soil Sampling Locations and Results

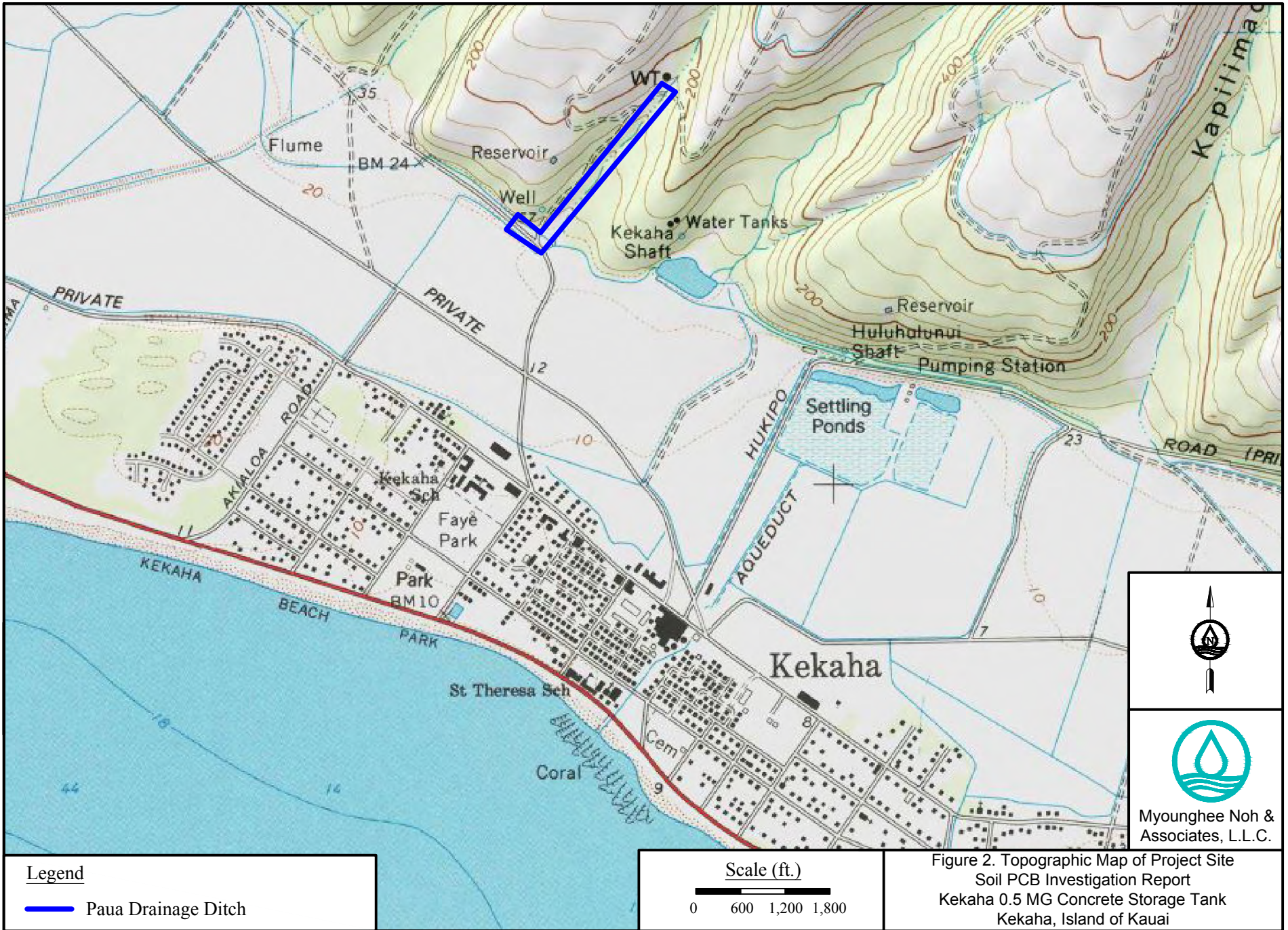
Figure 4B. DU2 Soil Sampling Locations and Results

Figure 4C. DU3 Soil Sampling Locations and Results

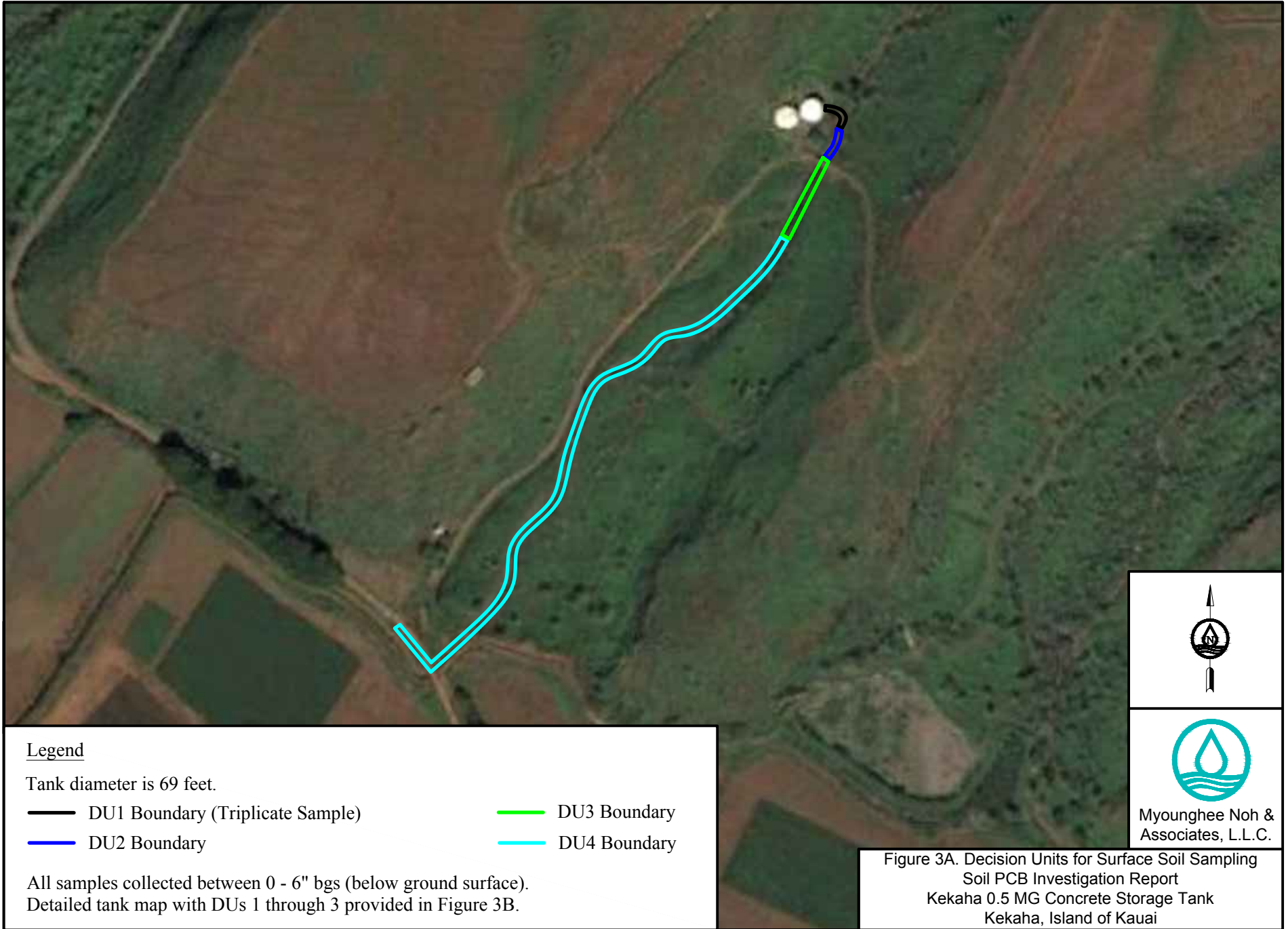
Figure 4D. DU4 Soil Sampling Locations and Results

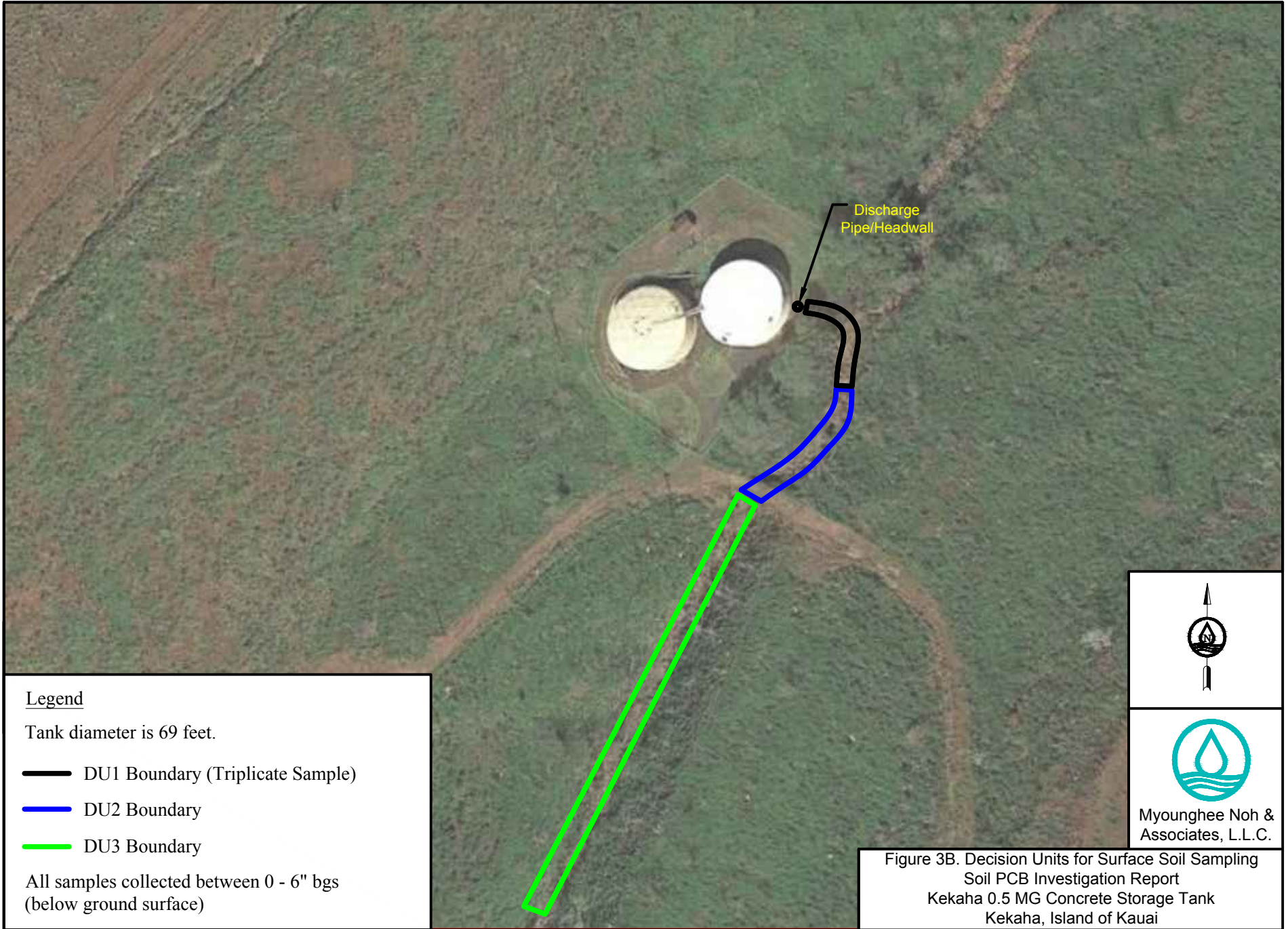


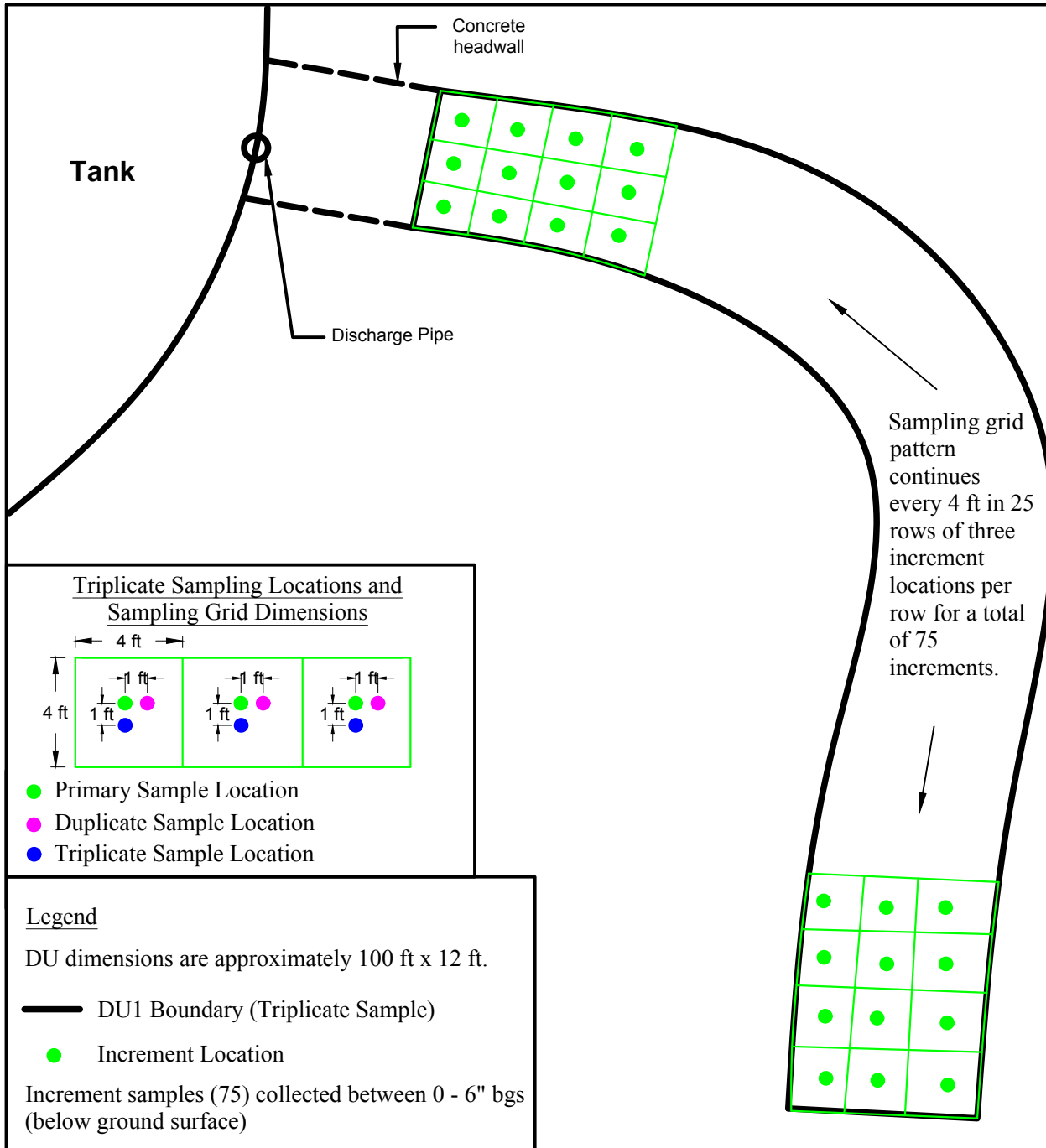
Figure 1. Site Location Map  
 Soil PCB Investigation Report  
 Kekaha 0.5 MG Concrete Storage Tank  
 Kekaha, Island of Kauai











Analytical Results (mg/kg)			
Analyte	DU1-MIS1 (Primary)	DU1-MIS2 (Duplicate)	DU1-MIS3 (Triplicate)
Total PCB	3.90	0.95	0.66
95% UCL	6.35		
Data Precision Review of Triplicate Samples	Mean: 1.84 mg/kg Standard Deviation: 1.79 Relative Standard Deviation: 97%		
Total PCB EAL: 1.2 mg/kg Total PCB TSCA Cleanup Standard: 25 mg/kg 95% UCL EAL: 1.8 mg/kg			

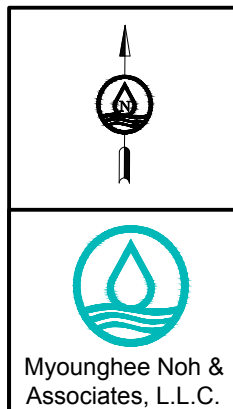
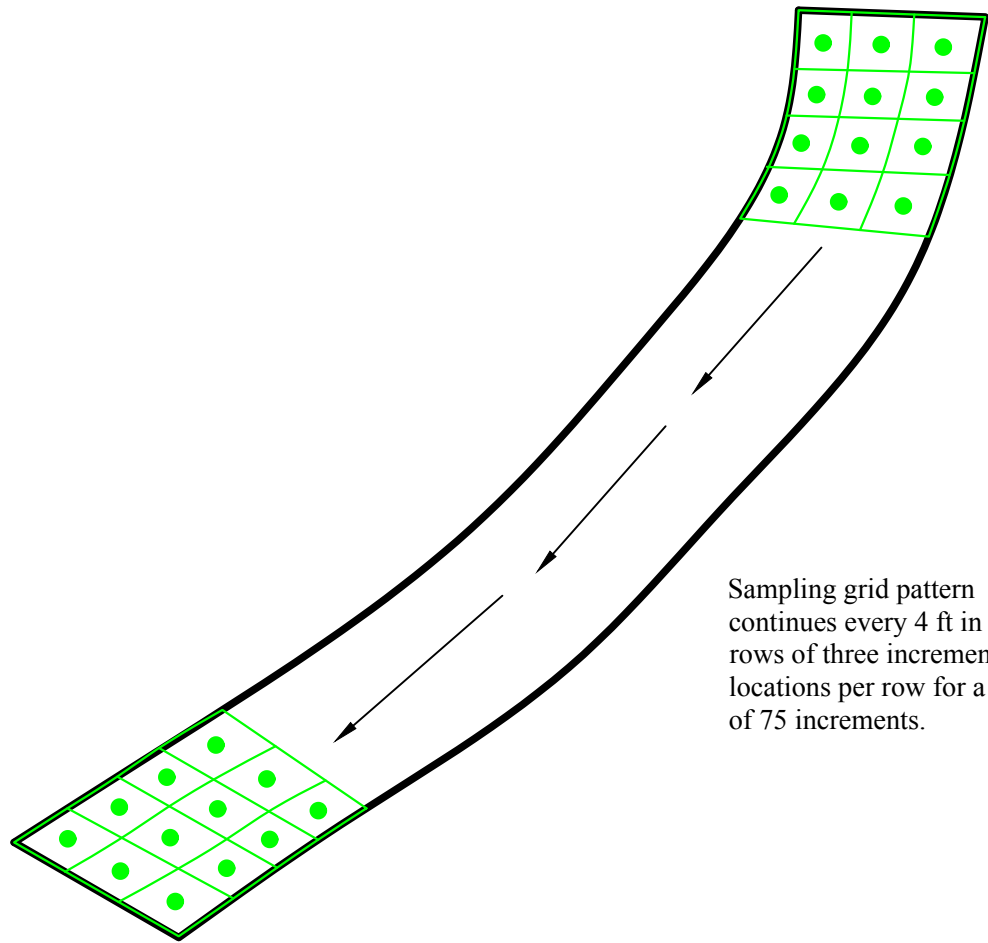
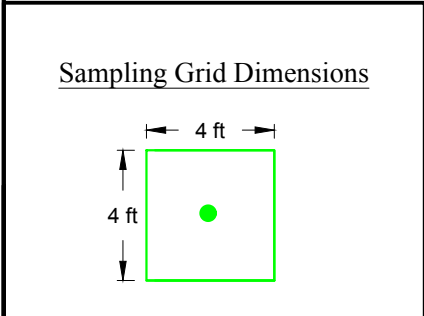


Figure 4A. DU1 Soil Sampling Locations and Results  
 Soil PCB Investigation Report  
 Kekaha 0.5 MG Concrete Storage Tank  
 Kekaha, Island of Kauai

Analytical Results (mg/kg)	
Analyte	DU2-MIS1
Total PCB	0.12
95% UCL	0.53
Total PCB EAL: 1.2 mg/kg Total PCB TSCA Cleanup Standard: 25 mg/kg 95% UCL EAL: 1.8 mg/kg	



Sampling grid pattern continues every 4 ft in 25 rows of three increment locations per row for a total of 75 increments.



Legend

DU dimensions are approximately 100 ft x 12 ft.

— DU2 Boundary

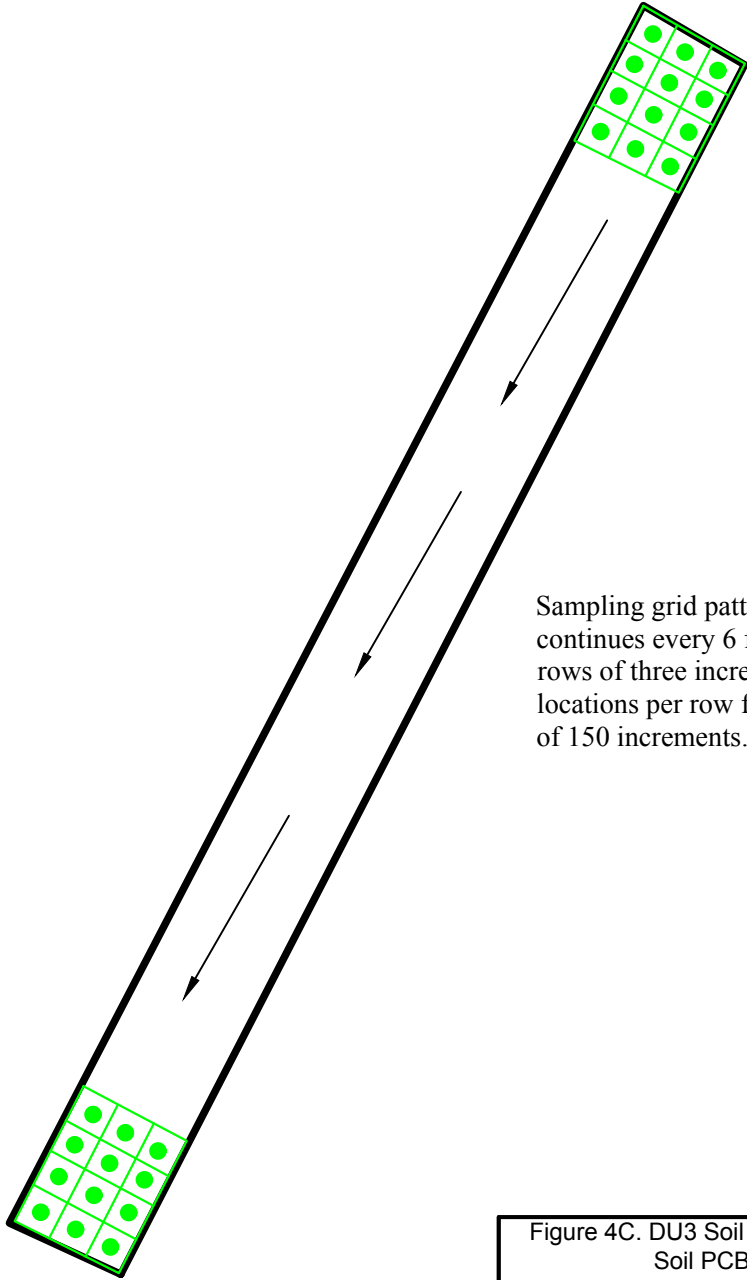
● Increment Location

Increment samples (75) collected between 0 - 6" bgs (below ground surface)

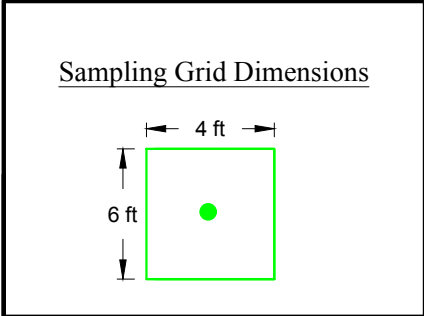
Myounghee Noh & Associates, L.L.C.

Figure 4B. DU2 Soil Sampling Locations and Results  
 Soil PCB Investigation Report  
 Kekaha 0.5 MG Concrete Storage Tank  
 Kekaha, Island of Kauai

Analytical Results (mg/kg)	
Analyte	DU3-MIS1
Total PCB	0.12
95% UCL	0.53
Total PCB EAL: 1.2 mg/kg Total PCB TSCA Cleanup Standard: 25 mg/kg 95% UCL EAL: 1.8 mg/kg	



Sampling grid pattern continues every 6 ft in 50 rows of three increment locations per row for a total of 150 increments.



Legend  
 DU dimensions are approximately 300 ft x 18 ft.

— DU3 Boundary

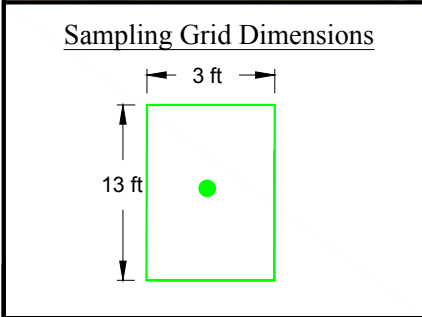
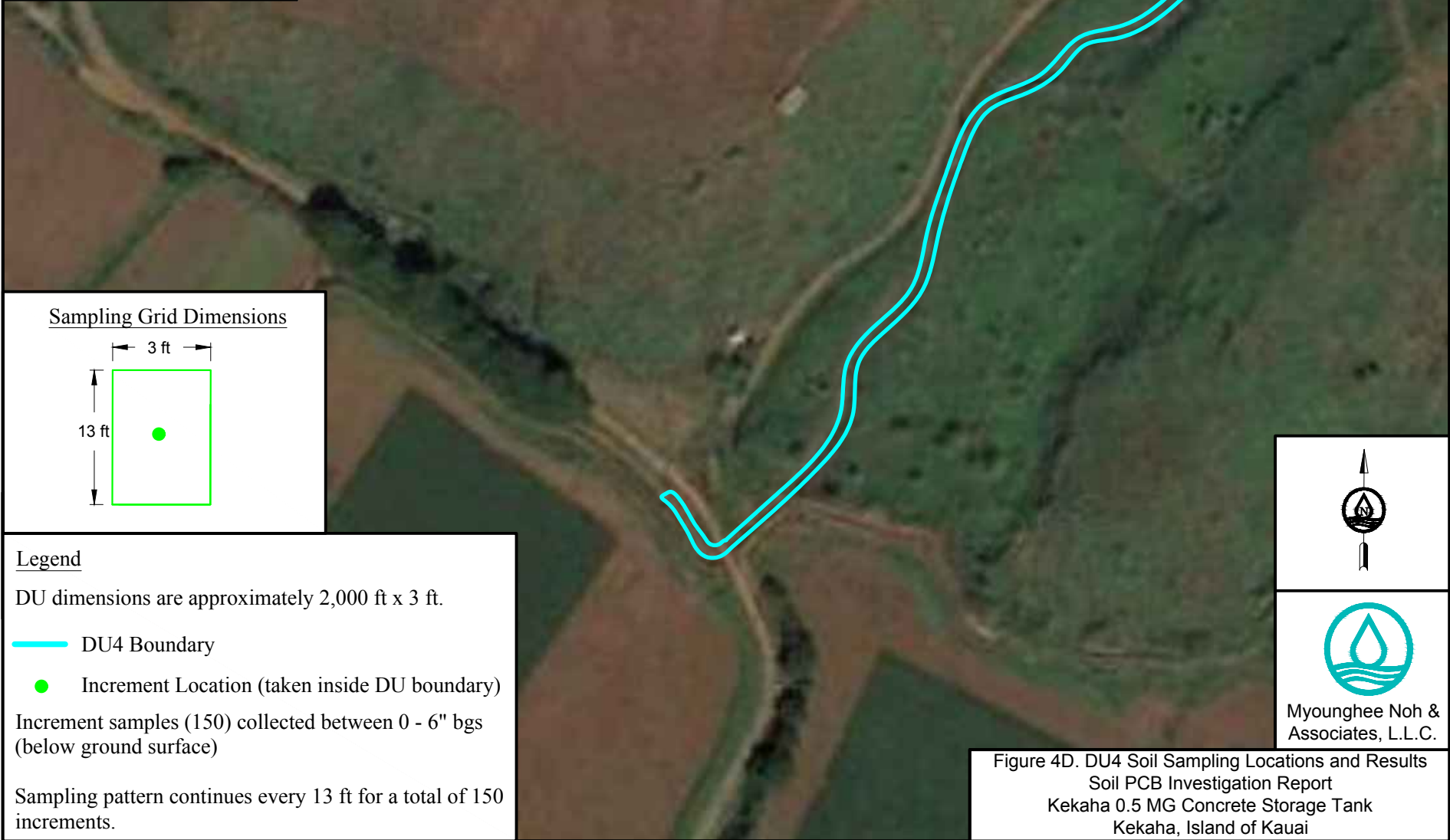
● Increment Location

Increment samples (150) collected between 0 - 6" bgs (below ground surface)

Myounghee Noh & Associates, L.L.C.

Figure 4C. DU3 Soil Sampling Locations and Results  
 Soil PCB Investigation Report  
 Kekaha 0.5 MG Concrete Storage Tank  
 Kekaha, Island of Kauai

Analytical Results (mg/kg)	
Analyte	DU4-MIS1
Total PCB	0.10
95% UCL	0.45
Total PCB EAL: 1.2 mg/kg Total PCB TSCA Cleanup Standard: 25 mg/kg 95% UCL EAL: 1.8 mg/kg	



**Legend**

DU dimensions are approximately 2,000 ft x 3 ft.

DU4 Boundary

Increment Location (taken inside DU boundary)

Increment samples (150) collected between 0 - 6" bgs (below ground surface)

Sampling pattern continues every 13 ft for a total of 150 increments.

Myounghee Noh & Associates, L.L.C.

Figure 4D. DU4 Soil Sampling Locations and Results  
 Soil PCB Investigation Report  
 Kekaha 0.5 MG Concrete Storage Tank  
 Kekaha, Island of Kauai

## **APPENDIX B. PHOTOGRAPHS**



Photograph 1. A view of tank discharge point/headwall to the drainage ditch. The DU was 12 ft wide by 100 ft long. The width of the drainage ditch varied (27 June 2018).



Photograph 2. A view of DU1 just beyond the discharge point. The drainage ditch was covered with vegetation, boulders, and rock. The DU was 12 ft wide by 100 ft long. The width of the drainage ditch varied (27 June 2018).



Photograph 3. A view of DU 2. Vegetation was cleared by DOW enough to access the drainage ditch. Entire continuous soil core plugs were collected using a hammer-head soil probe ( $\frac{7}{8}$ -inch diameter). The soil plug was combined in a 2-gallon bag inside of a bucket to generate a bulk MI sample. Then, the MI sample was transferred into a plastic sealable bag, sealed, double-bagged, labeled, and placed in a chilled insulated chest (27 June 2018).





Photograph 4. A view of a soil increment location. Due to sampler refusal, two to three soil boring attempts were made for each soil increment collected between 0-6 inches bgs (28 June 2018).



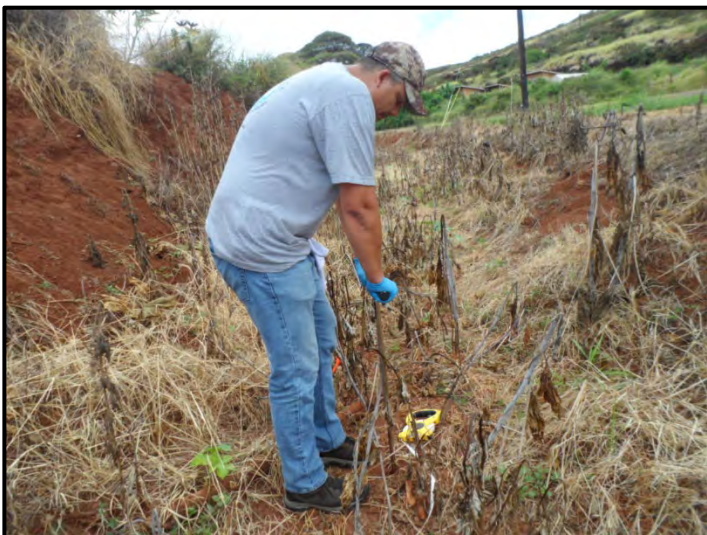
Photograph 5. A view of DU3. Vegetation was cleared by DOW enough to access the drainage ditch (27 June 2018).



Photograph 6. A view of DU4 along the drainage ditch. Vegetation was cleared by DOW enough to access the drainage ditch (28 June 2018).



Photograph 7. Soil sampling in DU4 (28 June 2018). Dense vegetation was observed throughout the DU.



Photograph 8. A view of sample collection in DU4, along Kokee Road (28 June 2018). The DU4 in the Kokee Road vicinity was the end of the drainage ditch in a depressed area where water might be collected during heavy rainfall.

**APPENDIX C. LABORATORY ANALYTICAL REPORT**

# TestAmerica

THE LEADER IN ENVIRONMENTAL TESTING

## ANALYTICAL REPORT

TestAmerica Laboratories, Inc.  
TestAmerica Sacramento  
880 Riverside Parkway  
West Sacramento, CA 95605  
Tel: (916)373-5600

TestAmerica Job ID: 320-40847-1  
Client Project/Site: KEKAHA, ISLAND OF KAUAI

For:  
Myounghee Noh & Associates  
99-1046 Iwaena Street, Suite 210A  
Aiea, Hawaii 96701

Attn: Eunjin Kotkovetz

*Cesar C Cortes*

Authorized for release by:  
7/27/2018 6:17:35 PM

Cesar Cortes, Project Management Assistant I  
(916)373-5600  
[cesar.cortes@testamericainc.com](mailto:cesar.cortes@testamericainc.com)

### LINKS

Review your project  
results through  
**TotalAccess**

Have a Question?



Visit us at:  
[www.testamericainc.com](http://www.testamericainc.com)

*The test results in this report meet all 2003 NELAC and 2009 TNI requirements for accredited parameters, exceptions are noted in this report. This report may not be reproduced except in full, and with written approval from the laboratory. For questions please contact the Project Manager at the e-mail address or telephone number listed on this page.*

*This report has been electronically signed and authorized by the signatory. Electronic signature is intended to be the legally binding equivalent of a traditionally handwritten signature.*

*Results relate only to the items tested and the sample(s) as received by the laboratory.*

- 1
- 2
- 3
- 4
- 5
- 6
- 7
- 8
- 9
- 10
- 11
- 12
- 13
- 14
- 15



# Table of Contents

Cover Page . . . . .	1
Table of Contents . . . . .	2
Definitions/Glossary . . . . .	3
Case Narrative . . . . .	4
Detection Summary . . . . .	5
Client Sample Results . . . . .	6
Surrogate Summary . . . . .	8
QC Sample Results . . . . .	9
QC Association Summary . . . . .	11
Lab Chronicle . . . . .	12
Certification Summary . . . . .	14
Method Summary . . . . .	15
Sample Summary . . . . .	16
Chain of Custody . . . . .	17
Receipt Checklists . . . . .	18

# Definitions/Glossary

Client: Myounghee Noh & Associates  
Project/Site: KEKAHA, ISLAND OF KAUAI

TestAmerica Job ID: 320-40847-1

## Qualifiers

### GC Semi VOA

Qualifier	Qualifier Description
J1	Estimated: The quantitation is an estimation due to discrepancies in meeting certain analyte-specific quality control criteria.
M	Manual integrated compound.
U	Undetected at the Limit of Detection.
D	The reported value is from a dilution.
J	Estimated: The analyte was positively identified; the quantitation is an estimation
4	MS, MSD: The analyte present in the original sample is greater than 4 times the matrix spike concentration; therefore, control limits are not applicable.

## Glossary

Abbreviation	These commonly used abbreviations may or may not be present in this report.
α	Listed under the "D" column to designate that the result is reported on a dry weight basis
%R	Percent Recovery
CFL	Contains Free Liquid
CNF	Contains No Free Liquid
DER	Duplicate Error Ratio (normalized absolute difference)
Dil Fac	Dilution Factor
DL	Detection Limit (DoD/DOE)
DL, RA, RE, IN	Indicates a Dilution, Re-analysis, Re-extraction, or additional Initial metals/anion analysis of the sample
DLC	Decision Level Concentration (Radiochemistry)
EDL	Estimated Detection Limit (Dioxin)
LOD	Limit of Detection (DoD/DOE)
LOQ	Limit of Quantitation (DoD/DOE)
MDA	Minimum Detectable Activity (Radiochemistry)
MDC	Minimum Detectable Concentration (Radiochemistry)
MDL	Method Detection Limit
ML	Minimum Level (Dioxin)
NC	Not Calculated
ND	Not Detected at the reporting limit (or MDL or EDL if shown)
PQL	Practical Quantitation Limit
QC	Quality Control
RER	Relative Error Ratio (Radiochemistry)
RL	Reporting Limit or Requested Limit (Radiochemistry)
RPD	Relative Percent Difference, a measure of the relative difference between two points
TEF	Toxicity Equivalent Factor (Dioxin)
TEQ	Toxicity Equivalent Quotient (Dioxin)

# Case Narrative

Client: Myounghee Noh & Associates  
Project/Site: KEKAHA, ISLAND OF KAUAI

TestAmerica Job ID: 320-40847-1

---

**Job ID: 320-40847-1**

---

**Laboratory: TestAmerica Sacramento**

## Narrative

### Receipt

The samples were received on 7/3/2018 at 9:30 AM; the samples arrived in good condition, properly preserved and, where required, on ice. The temperatures of the 2 coolers at receipt time were 1.2° C and 2.9° C.

### Method 8082A

The following samples required a dilution due to the nature of the sample matrix: DU1-MIS1 (320-40847-1), DU1-MIS1 (320-40847-1[MS]), DU1-MIS1 (320-40847-1[MSD]), DU1-MIS2 (320-40847-2) and DU1-MIS3 (320-40847-3). Because of this dilution, the surrogate spike concentration in the sample was reduced to a level where the recovery calculation does not provide useful information. Elevated reporting limits (RLs) are provided.

No additional analytical or quality issues were noted, other than those described above or in the Definitions/Glossary page.

# Detection Summary

Client: Myounghee Noh & Associates  
Project/Site: KEKAHA, ISLAND OF KAUAI

TestAmerica Job ID: 320-40847-1

## Client Sample ID: DU1-MIS1

## Lab Sample ID: 320-40847-1

Analyte	Result	Qualifier	LOQ	DL	Unit	Dil Fac	D	Method	Prep Type
PCB-1260	3000	D J1	340	29	ug/Kg	10		8082A	Total/NA

## Client Sample ID: DU1-MIS2

## Lab Sample ID: 320-40847-2

Analyte	Result	Qualifier	LOQ	DL	Unit	Dil Fac	D	Method	Prep Type
PCB-1260	510	D	160	14	ug/Kg	5		8082A	Total/NA

## Client Sample ID: DU1-MIS3

## Lab Sample ID: 320-40847-3

Analyte	Result	Qualifier	LOQ	DL	Unit	Dil Fac	D	Method	Prep Type
PCB-1260	480	D	66	5.8	ug/Kg	2		8082A	Total/NA

## Client Sample ID: DU2-MIS1

## Lab Sample ID: 320-40847-4

Analyte	Result	Qualifier	LOQ	DL	Unit	Dil Fac	D	Method	Prep Type
PCB-1260	32	J	33	2.9	ug/Kg	1		8082A	Total/NA

## Client Sample ID: DU3-MIS1

## Lab Sample ID: 320-40847-5

Analyte	Result	Qualifier	LOQ	DL	Unit	Dil Fac	D	Method	Prep Type
PCB-1260	25	J	34	3.0	ug/Kg	1		8082A	Total/NA

## Client Sample ID: DU4-MIS1

## Lab Sample ID: 320-40847-6

Analyte	Result	Qualifier	LOQ	DL	Unit	Dil Fac	D	Method	Prep Type
PCB-1260	4.5	J	34	3.0	ug/Kg	1		8082A	Total/NA

This Detection Summary does not include radiochemical test results.

TestAmerica Sacramento



# Client Sample Results

Client: Myounghee Noh & Associates  
 Project/Site: KEKAHA, ISLAND OF KAUAI

TestAmerica Job ID: 320-40847-1

## Client Sample ID: DU1-MIS1

Date Collected: 06/27/18 16:00

Date Received: 07/03/18 09:30

## Lab Sample ID: 320-40847-1

Matrix: Solid

### Method: 8082A - Polychlorinated Biphenyls (PCBs) by Gas Chromatography

Analyte	Result	Qualifier	LOQ	DL	Unit	D	Prepared	Analyzed	Dil Fac
PCB-1016	100	U M J1	340	35	ug/Kg		07/10/18 11:16	07/26/18 12:33	10
PCB-1221	150	U	340	53	ug/Kg		07/10/18 11:16	07/26/18 12:33	10
PCB-1232	200	U M	340	65	ug/Kg		07/10/18 11:16	07/26/18 12:33	10
PCB-1242	200	U M	340	75	ug/Kg		07/10/18 11:16	07/26/18 12:33	10
PCB-1248	150	U M	340	58	ug/Kg		07/10/18 11:16	07/26/18 12:33	10
PCB-1254	100	U M	340	27	ug/Kg		07/10/18 11:16	07/26/18 12:33	10
<b>PCB-1260</b>	<b>3000</b>	<b>D J1</b>	340	29	ug/Kg		07/10/18 11:16	07/26/18 12:33	10

Surrogate	%Recovery	Qualifier	Limits	Prepared	Analyzed	Dil Fac
DCB Decachlorobiphenyl	113		60 - 125	07/10/18 11:16	07/26/18 12:33	10
DCB Decachlorobiphenyl	123		60 - 125	07/10/18 11:16	07/26/18 12:33	10

## Client Sample ID: DU1-MIS2

Date Collected: 06/27/18 16:00

Date Received: 07/03/18 09:30

## Lab Sample ID: 320-40847-2

Matrix: Solid

### Method: 8082A - Polychlorinated Biphenyls (PCBs) by Gas Chromatography

Analyte	Result	Qualifier	LOQ	DL	Unit	D	Prepared	Analyzed	Dil Fac
PCB-1016	49	U M	160	17	ug/Kg		07/10/18 11:16	07/26/18 13:35	5
PCB-1221	74	U	160	26	ug/Kg		07/10/18 11:16	07/26/18 13:35	5
PCB-1232	99	U M	160	32	ug/Kg		07/10/18 11:16	07/26/18 13:35	5
PCB-1242	99	U M	160	37	ug/Kg		07/10/18 11:16	07/26/18 13:35	5
PCB-1248	74	U M	160	28	ug/Kg		07/10/18 11:16	07/26/18 13:35	5
PCB-1254	49	U M	160	13	ug/Kg		07/10/18 11:16	07/26/18 13:35	5
<b>PCB-1260</b>	<b>510</b>	<b>D</b>	160	14	ug/Kg		07/10/18 11:16	07/26/18 13:35	5

Surrogate	%Recovery	Qualifier	Limits	Prepared	Analyzed	Dil Fac
DCB Decachlorobiphenyl	80		60 - 125	07/10/18 11:16	07/26/18 13:35	5
DCB Decachlorobiphenyl	85		60 - 125	07/10/18 11:16	07/26/18 13:35	5

## Client Sample ID: DU1-MIS3

Date Collected: 06/27/18 16:00

Date Received: 07/03/18 09:30

## Lab Sample ID: 320-40847-3

Matrix: Solid

### Method: 8082A - Polychlorinated Biphenyls (PCBs) by Gas Chromatography

Analyte	Result	Qualifier	LOQ	DL	Unit	D	Prepared	Analyzed	Dil Fac
PCB-1016	20	U M	66	6.8	ug/Kg		07/10/18 11:16	07/26/18 13:55	2
PCB-1221	30	U	66	10	ug/Kg		07/10/18 11:16	07/26/18 13:55	2
PCB-1232	40	U M	66	13	ug/Kg		07/10/18 11:16	07/26/18 13:55	2
PCB-1242	40	U M	66	15	ug/Kg		07/10/18 11:16	07/26/18 13:55	2
PCB-1248	30	U M	66	11	ug/Kg		07/10/18 11:16	07/26/18 13:55	2
PCB-1254	20	U M	66	5.4	ug/Kg		07/10/18 11:16	07/26/18 13:55	2
<b>PCB-1260</b>	<b>480</b>	<b>D</b>	66	5.8	ug/Kg		07/10/18 11:16	07/26/18 13:55	2

Surrogate	%Recovery	Qualifier	Limits	Prepared	Analyzed	Dil Fac
DCB Decachlorobiphenyl	88		60 - 125	07/10/18 11:16	07/26/18 13:55	2
DCB Decachlorobiphenyl	90		60 - 125	07/10/18 11:16	07/26/18 13:55	2

TestAmerica Sacramento

# Client Sample Results

Client: Myounghee Noh & Associates  
Project/Site: KEKAHA, ISLAND OF KAUAI

TestAmerica Job ID: 320-40847-1

## Client Sample ID: DU2-MIS1

Date Collected: 06/28/18 10:30

Date Received: 07/03/18 09:30

## Lab Sample ID: 320-40847-4

Matrix: Solid

### Method: 8082A - Polychlorinated Biphenyls (PCBs) by Gas Chromatography

Analyte	Result	Qualifier	LOQ	DL	Unit	D	Prepared	Analyzed	Dil Fac
PCB-1016	9.9	U M	33	3.3	ug/Kg		07/10/18 11:16	07/26/18 14:16	1
PCB-1221	15	U M	33	5.1	ug/Kg		07/10/18 11:16	07/26/18 14:16	1
PCB-1232	20	U M	33	6.3	ug/Kg		07/10/18 11:16	07/26/18 14:16	1
PCB-1242	20	U M	33	7.3	ug/Kg		07/10/18 11:16	07/26/18 14:16	1
PCB-1248	15	U M	33	5.6	ug/Kg		07/10/18 11:16	07/26/18 14:16	1
PCB-1254	9.9	U M	33	2.7	ug/Kg		07/10/18 11:16	07/26/18 14:16	1
<b>PCB-1260</b>	<b>32</b>	<b>J</b>	33	2.9	ug/Kg		07/10/18 11:16	07/26/18 14:16	1

Surrogate	%Recovery	Qualifier	Limits	Prepared	Analyzed	Dil Fac
DCB Decachlorobiphenyl	71		60 - 125	07/10/18 11:16	07/26/18 14:16	1
DCB Decachlorobiphenyl	75		60 - 125	07/10/18 11:16	07/26/18 14:16	1

## Client Sample ID: DU3-MIS1

Date Collected: 06/28/18 14:30

Date Received: 07/03/18 09:30

## Lab Sample ID: 320-40847-5

Matrix: Solid

### Method: 8082A - Polychlorinated Biphenyls (PCBs) by Gas Chromatography

Analyte	Result	Qualifier	LOQ	DL	Unit	D	Prepared	Analyzed	Dil Fac
PCB-1016	10	U M	34	3.5	ug/Kg		07/10/18 11:16	07/26/18 14:36	1
PCB-1221	15	U	34	5.3	ug/Kg		07/10/18 11:16	07/26/18 14:36	1
PCB-1232	20	U M	34	6.6	ug/Kg		07/10/18 11:16	07/26/18 14:36	1
PCB-1242	20	U M	34	7.6	ug/Kg		07/10/18 11:16	07/26/18 14:36	1
PCB-1248	15	U M	34	5.8	ug/Kg		07/10/18 11:16	07/26/18 14:36	1
PCB-1254	10	U M	34	2.8	ug/Kg		07/10/18 11:16	07/26/18 14:36	1
<b>PCB-1260</b>	<b>25</b>	<b>J</b>	34	3.0	ug/Kg		07/10/18 11:16	07/26/18 14:36	1

Surrogate	%Recovery	Qualifier	Limits	Prepared	Analyzed	Dil Fac
DCB Decachlorobiphenyl	78		60 - 125	07/10/18 11:16	07/26/18 14:36	1
DCB Decachlorobiphenyl	82		60 - 125	07/10/18 11:16	07/26/18 14:36	1

## Client Sample ID: DU4-MIS1

Date Collected: 06/28/18 16:30

Date Received: 07/03/18 09:30

## Lab Sample ID: 320-40847-6

Matrix: Solid

### Method: 8082A - Polychlorinated Biphenyls (PCBs) by Gas Chromatography

Analyte	Result	Qualifier	LOQ	DL	Unit	D	Prepared	Analyzed	Dil Fac
PCB-1016	10	U	34	3.5	ug/Kg		07/10/18 11:16	07/26/18 15:37	1
PCB-1221	15	U	34	5.3	ug/Kg		07/10/18 11:16	07/26/18 15:37	1
PCB-1232	21	U	34	6.6	ug/Kg		07/10/18 11:16	07/26/18 15:37	1
PCB-1242	21	U	34	7.6	ug/Kg		07/10/18 11:16	07/26/18 15:37	1
PCB-1248	15	U M	34	5.9	ug/Kg		07/10/18 11:16	07/26/18 15:37	1
PCB-1254	10	U M	34	2.8	ug/Kg		07/10/18 11:16	07/26/18 15:37	1
<b>PCB-1260</b>	<b>4.5</b>	<b>J</b>	34	3.0	ug/Kg		07/10/18 11:16	07/26/18 15:37	1

Surrogate	%Recovery	Qualifier	Limits	Prepared	Analyzed	Dil Fac
DCB Decachlorobiphenyl	77		60 - 125	07/10/18 11:16	07/26/18 15:37	1
DCB Decachlorobiphenyl	83		60 - 125	07/10/18 11:16	07/26/18 15:37	1

TestAmerica Sacramento

# Surrogate Summary

Client: Myounghee Noh & Associates  
Project/Site: KEKAHA, ISLAND OF KAUAI

TestAmerica Job ID: 320-40847-1

## Method: 8082A - Polychlorinated Biphenyls (PCBs) by Gas Chromatography

Matrix: Solid

Prep Type: Total/NA

### Percent Surrogate Recovery (Acceptance Limits)

Lab Sample ID	Client Sample ID	DCBP1 (60-125)	DCBP2 (60-125)
320-40847-1	DU1-MIS1	113	123
320-40847-1 MS	DU1-MIS1	91	
320-40847-1 MSD	DU1-MIS1	104	
320-40847-2	DU1-MIS2	80	85
320-40847-3	DU1-MIS3	88	90
320-40847-4	DU2-MIS1	71	75
320-40847-5	DU3-MIS1	78	82
320-40847-6	DU4-MIS1	77	83
320-40847-6 DU	DU4-MIS1	81	78
320-40847-6 TRL	DU4-MIS1	90	88
LCS 320-236318/2-A	Lab Control Sample	109	
MB 320-236318/1-A	Method Blank	96	89

#### Surrogate Legend

DCBP = DCB Decachlorobiphenyl

# QC Sample Results

Client: Myounghee Noh & Associates  
 Project/Site: KEKAHA, ISLAND OF KAUAI

TestAmerica Job ID: 320-40847-1

## Method: 8082A - Polychlorinated Biphenyls (PCBs) by Gas Chromatography

**Lab Sample ID: MB 320-236318/1-A**  
**Matrix: Solid**  
**Analysis Batch: 236295**

**Client Sample ID: Method Blank**  
**Prep Type: Total/NA**  
**Prep Batch: 236318**

Analyte	MB MB		LOQ	DL	Unit	D	Prepared	Analyzed	Dil Fac
	Result	Qualifier							
PCB-1016	10	U	33	3.4	ug/Kg		07/10/18 11:16	07/26/18 11:52	1
PCB-1221	15	U	33	5.2	ug/Kg		07/10/18 11:16	07/26/18 11:52	1
PCB-1232	20	U	33	6.4	ug/Kg		07/10/18 11:16	07/26/18 11:52	1
PCB-1242	20	U	33	7.4	ug/Kg		07/10/18 11:16	07/26/18 11:52	1
PCB-1248	15	U	33	5.7	ug/Kg		07/10/18 11:16	07/26/18 11:52	1
PCB-1254	10	U	33	2.7	ug/Kg		07/10/18 11:16	07/26/18 11:52	1
PCB-1260	10	U	33	2.9	ug/Kg		07/10/18 11:16	07/26/18 11:52	1

Surrogate	MB MB		Limits	Prepared	Analyzed	Dil Fac
	%Recovery	Qualifier				
DCB Decachlorobiphenyl	96		60 - 125	07/10/18 11:16	07/26/18 11:52	1
DCB Decachlorobiphenyl	89		60 - 125	07/10/18 11:16	07/26/18 11:52	1

**Lab Sample ID: LCS 320-236318/2-A**  
**Matrix: Solid**  
**Analysis Batch: 236295**

**Client Sample ID: Lab Control Sample**  
**Prep Type: Total/NA**  
**Prep Batch: 236318**

Analyte	Spike Added	LCS Result	LCS Qualifier	Unit	D	%Rec	%Rec. Limits
PCB-1260	66.7	72.3		ug/Kg		109	53 - 140

Surrogate	LCS LCS		Limits
	%Recovery	Qualifier	
DCB Decachlorobiphenyl	109		60 - 125

**Lab Sample ID: 320-40847-1 MS**  
**Matrix: Solid**  
**Analysis Batch: 236295**

**Client Sample ID: DU1-MIS1**  
**Prep Type: Total/NA**  
**Prep Batch: 236318**

Analyte	Sample Result	Sample Qualifier	Spike Added	MS Result	MS Qualifier	Unit	D	%Rec	%Rec. Limits
PCB-1260	3000	D J1	68.0	755	D 4	ug/Kg		-3372	53 - 140

Surrogate	MS MS		Limits
	%Recovery	Qualifier	
DCB Decachlorobiphenyl	91		60 - 125

**Lab Sample ID: 320-40847-1 MSD**  
**Matrix: Solid**  
**Analysis Batch: 236295**

**Client Sample ID: DU1-MIS1**  
**Prep Type: Total/NA**  
**Prep Batch: 236318**

Analyte	Sample Result	Sample Qualifier	Spike Added	MSD Result	MSD Qualifier	Unit	D	%Rec	%Rec. Limits	RPD	RPD Limit
PCB-1260	3000	D J1	65.7	991	D 4	ug/Kg		-3129	53 - 140	27	30

Surrogate	MSD MSD		Limits
	%Recovery	Qualifier	
DCB Decachlorobiphenyl	104		60 - 125

# QC Sample Results

Client: Myounghee Noh & Associates  
 Project/Site: KEKAHA, ISLAND OF KAUAI

TestAmerica Job ID: 320-40847-1

## Method: 8082A - Polychlorinated Biphenyls (PCBs) by Gas Chromatography (Continued)

**Lab Sample ID: 320-40847-6 DU**  
**Matrix: Solid**  
**Analysis Batch: 236295**

**Client Sample ID: DU4-MIS1**  
**Prep Type: Total/NA**  
**Prep Batch: 236318**

Analyte	Sample		DU		Unit	D	RPD	Limit
	Result	Qualifier	Result	Qualifier				
PCB-1016	10	U	9.9	U	ug/Kg		NC	30
PCB-1221	15	U	15	U	ug/Kg		NC	30
PCB-1232	21	U	20	U	ug/Kg		NC	
PCB-1242	21	U	20	U	ug/Kg		NC	
PCB-1248	15	U M	15	U M	ug/Kg		NC	
PCB-1254	10	U M	9.9	U M	ug/Kg		NC	
PCB-1260	4.5	J	4.37	J	ug/Kg		3	30

Surrogate	%Recovery	Qualifier	Limits
DCB Decachlorobiphenyl	81		60 - 125
DCB Decachlorobiphenyl	78		60 - 125

**Lab Sample ID: 320-40847-6 TRL**  
**Matrix: Solid**  
**Analysis Batch: 236295**

**Client Sample ID: DU4-MIS1**  
**Prep Type: Total/NA**  
**Prep Batch: 236318**

Analyte	Sample		TRL		Unit	D	RSD	Limit
	Result	Qualifier	Result	Qualifier				
PCB-1016	10	U	9.7	U	ug/Kg		NC	20
PCB-1221	15	U	15	U	ug/Kg		NC	20
PCB-1232	21	U	19	U	ug/Kg		NC	20
PCB-1242	21	U	19	U	ug/Kg		NC	20
PCB-1248	15	U M	15	U M	ug/Kg		NC	20
PCB-1254	10	U M	9.7	U M	ug/Kg		NC	20
PCB-1260	4.5	J	5.80	J	ug/Kg		16	20

Surrogate	%Recovery	Qualifier	Limits
DCB Decachlorobiphenyl	90		60 - 125
DCB Decachlorobiphenyl	88		60 - 125

# QC Association Summary

Client: Myounghee Noh & Associates  
 Project/Site: KEKAHA, ISLAND OF KAUAI

TestAmerica Job ID: 320-40847-1

## GC Semi VOA

### ISM Prep Batch: 232637

Lab Sample ID	Client Sample ID	Prep Type	Matrix	Method	Prep Batch
320-40847-1	DU1-MIS1	Total/NA	Solid	Increment, prep	
320-40847-2	DU1-MIS2	Total/NA	Solid	Increment, prep	
320-40847-3	DU1-MIS3	Total/NA	Solid	Increment, prep	
320-40847-4	DU2-MIS1	Total/NA	Solid	Increment, prep	
320-40847-5	DU3-MIS1	Total/NA	Solid	Increment, prep	
320-40847-6	DU4-MIS1	Total/NA	Solid	Increment, prep	
320-40847-1 MS	DU1-MIS1	Total/NA	Solid	Increment, prep	
320-40847-1 MSD	DU1-MIS1	Total/NA	Solid	Increment, prep	
320-40847-6 DU	DU4-MIS1	Total/NA	Solid	Increment, prep	
320-40847-6 TRL	DU4-MIS1	Total/NA	Solid	Increment, prep	

### Analysis Batch: 236295

Lab Sample ID	Client Sample ID	Prep Type	Matrix	Method	Prep Batch
320-40847-1	DU1-MIS1	Total/NA	Solid	8082A	236318
320-40847-2	DU1-MIS2	Total/NA	Solid	8082A	236318
320-40847-3	DU1-MIS3	Total/NA	Solid	8082A	236318
320-40847-4	DU2-MIS1	Total/NA	Solid	8082A	236318
320-40847-5	DU3-MIS1	Total/NA	Solid	8082A	236318
320-40847-6	DU4-MIS1	Total/NA	Solid	8082A	236318
MB 320-236318/1-A	Method Blank	Total/NA	Solid	8082A	236318
LCS 320-236318/2-A	Lab Control Sample	Total/NA	Solid	8082A	236318
320-40847-1 MS	DU1-MIS1	Total/NA	Solid	8082A	236318
320-40847-1 MSD	DU1-MIS1	Total/NA	Solid	8082A	236318
320-40847-6 DU	DU4-MIS1	Total/NA	Solid	8082A	236318
320-40847-6 TRL	DU4-MIS1	Total/NA	Solid	8082A	236318

### Prep Batch: 236318

Lab Sample ID	Client Sample ID	Prep Type	Matrix	Method	Prep Batch
320-40847-1	DU1-MIS1	Total/NA	Solid	3550B	232637
320-40847-2	DU1-MIS2	Total/NA	Solid	3550B	232637
320-40847-3	DU1-MIS3	Total/NA	Solid	3550B	232637
320-40847-4	DU2-MIS1	Total/NA	Solid	3550B	232637
320-40847-5	DU3-MIS1	Total/NA	Solid	3550B	232637
320-40847-6	DU4-MIS1	Total/NA	Solid	3550B	232637
MB 320-236318/1-A	Method Blank	Total/NA	Solid	3550B	
LCS 320-236318/2-A	Lab Control Sample	Total/NA	Solid	3550B	
320-40847-1 MS	DU1-MIS1	Total/NA	Solid	3550B	232637
320-40847-1 MSD	DU1-MIS1	Total/NA	Solid	3550B	232637
320-40847-6 DU	DU4-MIS1	Total/NA	Solid	3550B	232637
320-40847-6 TRL	DU4-MIS1	Total/NA	Solid	3550B	232637

# Lab Chronicle

Client: Myounghee Noh & Associates  
Project/Site: KEKAHA, ISLAND OF KAUAI

TestAmerica Job ID: 320-40847-1

**Client Sample ID: DU1-MIS1**

**Date Collected: 06/27/18 16:00**

**Date Received: 07/03/18 09:30**

**Lab Sample ID: 320-40847-1**

**Matrix: Solid**

Prep Type	Batch Type	Batch Method	Run	Dil Factor	Initial Amount	Final Amount	Batch Number	Prepared or Analyzed	Analyst	Lab
Total/NA	ISM Prep	Increment, prep					232637	07/05/18 22:03	AJC	TAL SAC
Total/NA	Prep	3550B			29.55 g	10 mL	236318	07/10/18 11:16	MSB	TAL SAC
Total/NA	Analysis	8082A		10			236295	07/26/18 12:33	RS1	TAL SAC

**Client Sample ID: DU1-MIS2**

**Date Collected: 06/27/18 16:00**

**Date Received: 07/03/18 09:30**

**Lab Sample ID: 320-40847-2**

**Matrix: Solid**

Prep Type	Batch Type	Batch Method	Run	Dil Factor	Initial Amount	Final Amount	Batch Number	Prepared or Analyzed	Analyst	Lab
Total/NA	ISM Prep	Increment, prep					232637	07/05/18 22:03	AJC	TAL SAC
Total/NA	Prep	3550B			30.35 g	10 mL	236318	07/10/18 11:16	MSB	TAL SAC
Total/NA	Analysis	8082A		5			236295	07/26/18 13:35	RS1	TAL SAC

**Client Sample ID: DU1-MIS3**

**Date Collected: 06/27/18 16:00**

**Date Received: 07/03/18 09:30**

**Lab Sample ID: 320-40847-3**

**Matrix: Solid**

Prep Type	Batch Type	Batch Method	Run	Dil Factor	Initial Amount	Final Amount	Batch Number	Prepared or Analyzed	Analyst	Lab
Total/NA	ISM Prep	Increment, prep					232637	07/05/18 22:03	AJC	TAL SAC
Total/NA	Prep	3550B			29.80 g	10 mL	236318	07/10/18 11:16	MSB	TAL SAC
Total/NA	Analysis	8082A		2			236295	07/26/18 13:55	RS1	TAL SAC

**Client Sample ID: DU2-MIS1**

**Date Collected: 06/28/18 10:30**

**Date Received: 07/03/18 09:30**

**Lab Sample ID: 320-40847-4**

**Matrix: Solid**

Prep Type	Batch Type	Batch Method	Run	Dil Factor	Initial Amount	Final Amount	Batch Number	Prepared or Analyzed	Analyst	Lab
Total/NA	ISM Prep	Increment, prep					232637	07/05/18 22:03	AJC	TAL SAC
Total/NA	Prep	3550B			30.45 g	10 mL	236318	07/10/18 11:16	MSB	TAL SAC
Total/NA	Analysis	8082A		1			236295	07/26/18 14:16	RS1	TAL SAC

**Client Sample ID: DU3-MIS1**

**Date Collected: 06/28/18 14:30**

**Date Received: 07/03/18 09:30**

**Lab Sample ID: 320-40847-5**

**Matrix: Solid**

Prep Type	Batch Type	Batch Method	Run	Dil Factor	Initial Amount	Final Amount	Batch Number	Prepared or Analyzed	Analyst	Lab
Total/NA	ISM Prep	Increment, prep					232637	07/05/18 22:03	AJC	TAL SAC
Total/NA	Prep	3550B			29.27 g	10 mL	236318	07/10/18 11:16	MSB	TAL SAC
Total/NA	Analysis	8082A		1			236295	07/26/18 14:36	RS1	TAL SAC

TestAmerica Sacramento

# Lab Chronicle

Client: Myounghee Noh & Associates  
Project/Site: KEKAHA, ISLAND OF KAUAI

TestAmerica Job ID: 320-40847-1

**Client Sample ID: DU4-MIS1**

**Lab Sample ID: 320-40847-6**

**Date Collected: 06/28/18 16:30**

**Matrix: Solid**

**Date Received: 07/03/18 09:30**

Prep Type	Batch Type	Batch Method	Run	Dil Factor	Initial Amount	Final Amount	Batch Number	Prepared or Analyzed	Analyst	Lab
Total/NA	ISM Prep	Increment, prep					232637	07/05/18 22:03	AJC	TAL SAC
Total/NA	Prep	3550B			29.21 g	10 mL	236318	07/10/18 11:16	MSB	TAL SAC
Total/NA	Analysis	8082A		1			236295	07/26/18 15:37	RS1	TAL SAC

**Laboratory References:**

TAL SAC = TestAmerica Sacramento, 880 Riverside Parkway, West Sacramento, CA 95605, TEL (916)373-5600

- 1
- 2
- 3
- 4
- 5
- 6
- 7
- 8
- 9
- 10
- 11
- 12
- 13
- 14
- 15



# Accreditation/Certification Summary

Client: Myounghee Noh & Associates  
 Project/Site: KEKAHA, ISLAND OF KAUAI

TestAmerica Job ID: 320-40847-1

## Laboratory: TestAmerica Sacramento

Unless otherwise noted, all analytes for this laboratory were covered under each accreditation/certification below.

Authority	Program	EPA Region	Identification Number	Expiration Date
ANAB	DoD ELAP		L2468	01-20-21

Analysis Method	Prep Method	Matrix	Analyte
USDA	Federal		P330-11-00436 01-17-21

The following analytes are included in this report, but accreditation/certification is not offered by the governing authority:

Analysis Method	Prep Method	Matrix	Analyte
8082A	3550B	Solid	PCB-1016
8082A	3550B	Solid	PCB-1221
8082A	3550B	Solid	PCB-1232
8082A	3550B	Solid	PCB-1242
8082A	3550B	Solid	PCB-1248
8082A	3550B	Solid	PCB-1254
8082A	3550B	Solid	PCB-1260



# Method Summary

Client: Myounghee Noh & Associates  
Project/Site: KEKAHA, ISLAND OF KAUAI

TestAmerica Job ID: 320-40847-1

Method	Method Description	Protocol	Laboratory
8082A	Polychlorinated Biphenyls (PCBs) by Gas Chromatography	SW846	TAL SAC
3550B	Ultrasonic Extraction	SW846	TAL SAC
Increment, prep	ISM - Dry, Disaggregate, Sieve, 2 D Slabcake Subsample	EPA	TAL SAC

#### Protocol References:

EPA = US Environmental Protection Agency

SW846 = "Test Methods For Evaluating Solid Waste, Physical/Chemical Methods", Third Edition, November 1986 And Its Updates.

#### Laboratory References:

TAL SAC = TestAmerica Sacramento, 880 Riverside Parkway, West Sacramento, CA 95605, TEL (916)373-5600

1

2

3

4

5

6

7

8

9

10

11

12

13

14

15

# Sample Summary

Client: Myounghee Noh & Associates  
Project/Site: KEKAHA, ISLAND OF KAUAI

TestAmerica Job ID: 320-40847-1

Lab Sample ID	Client Sample ID	Matrix	Collected	Received
320-40847-1	DU1-MIS1	Solid	06/27/18 16:00	07/03/18 09:30
320-40847-2	DU1-MIS2	Solid	06/27/18 16:00	07/03/18 09:30
320-40847-3	DU1-MIS3	Solid	06/27/18 16:00	07/03/18 09:30
320-40847-4	DU2-MIS1	Solid	06/28/18 10:30	07/03/18 09:30
320-40847-5	DU3-MIS1	Solid	06/28/18 14:30	07/03/18 09:30
320-40847-6	DU4-MIS1	Solid	06/28/18 16:30	07/03/18 09:30

1

2

3

4

5

6

7

8

9

10

11

12

13

14

15

West Sacramento, CA 95605  
phone 916.373.5600 fax

Regulatory Program:  DW  NPDES  RCRA  Other: **TSCA PCB**

TestAmerica Laboratories, Inc.

<b>Client Contact</b>	<b>Project Manager:</b> Eunjin Kotkovetz	<b>Site Contact:</b> N/A	<b>Date:</b>	<b>COC No:</b>
Myounghee Noh & Associates, L.L.C.	<b>Tel/Fax:</b> eunjin@noh-associates.com	<b>Lab Contact:</b> N/A	<b>Carrier:</b>	1 of 1 COCs
99-1046 Iwaena St. Suite 210A	<b>Analysis Turnaround Time</b>			<b>Sampler:</b>
Aiea, HI, 96701	<input checked="" type="checkbox"/> CALENDAR DAYS <input type="checkbox"/> WORKING DAYS			<b>For Lab Use Only:</b>
(808) 853-3137 Phone	TAT if different from Below Standard			Walk-in Client:
(808) 484-4660 FAX	<input type="checkbox"/> 2 weeks			Lab Sampling:
Project Name: KEKAHA 0.5 MG WATER TANK	<input type="checkbox"/> 1 week			Job / SDG No.:
Site: KEKAHA, ISLAND OF KAUAI	<input type="checkbox"/> 2 days			
P O # 12388	<input type="checkbox"/> 1 day			

Sample Identification	Sample Date	Sample Time	Sample Type (C=Comp, G=Grab)	Matrix	# of Cont.	Filtered Sample (Y/N)	Perform MS / MSD (Y/N)	MIS Preparation (Hawaii Dept. of H PCB (8082)	Sample Specific Notes:
DU1-MIS1	6/27/18	1600	MIS	soil	1	Y	X	X	
DU1-MIS2	6/27/18	1600	MIS	soil	1		X	X	
DU1-MIS3	6/27/18	1600	MIS	soil	1		X	X	
DU2-MIS1	6/28/18	1030	MIS	soil	1		X	X	
DU3-MIS1	6/28/18	1430	MIS	soil	1		X	X	
DU4-MIS1	6/28/18	1630	MIS	soil	1		X	X	



**Preservation Used:** 1= Ice, 2= HCl; 3= H2SO4; 4=HNO3; 5=NaOH; 6= Other

**Possible Hazard Identification:** Are any samples from a listed EPA Hazardous Waste? Please List any EPA Waste Codes for the sample in the Comments Section if the lab is to dispose of the sample.

Non-Hazard  Flammable  Skin Irritant  Poison B  Unknown

**Sample Disposal ( A fee may be assessed if samples are retained longer than 1 month)**

Return to Client  Disposal by Lab  Archive for \_\_\_\_\_ Months

**Special Instructions/QC Requirements & Comments:**

Cooler Temp. (°C): Obs'd: 1.2°C, 2.9°C, 2.9°C, 1.2°C  
Therm ID No.: AK-2, AK-2

Custody Seals Intact:  Yes  No

Custody Seal No.:

Relinquished by: Eunjin Kotkovetz	Company: MNA	Date/Time: 07/02/18	Received by: [Signature]	Company: [Signature]	Date/Time: 7/3/18 930
Relinquished by:	Company:	Date/Time:	Received by:	Company:	Date/Time:
Relinquished by:	Company:	Date/Time:	Received in Laboratory by:	Company:	Date/Time:



# Login Sample Receipt Checklist

Client: Myounghee Noh & Associates

Job Number: 320-40847-1

**Login Number: 40847**

**List Source: TestAmerica Sacramento**

**List Number: 1**

**Creator: Nelson, Kym D**

Question	Answer	Comment
Radioactivity wasn't checked or is </= background as measured by a survey meter.	True	
The cooler's custody seal, if present, is intact.	True	
Sample custody seals, if present, are intact.	N/A	
The cooler or samples do not appear to have been compromised or tampered with.	True	
Samples were received on ice.	True	GEL PACKS
Cooler Temperature is acceptable.	True	
Cooler Temperature is recorded.	True	
COC is present.	True	
COC is filled out in ink and legible.	True	
COC is filled out with all pertinent information.	True	
Is the Field Sampler's name present on COC?	False	
There are no discrepancies between the containers received and the COC.	True	
Samples are received within Holding Time (excluding tests with immediate HTs)	True	
Sample containers have legible labels.	True	
Containers are not broken or leaking.	True	
Sample collection date/times are provided.	True	
Appropriate sample containers are used.	True	
Sample bottles are completely filled.	True	
Sample Preservation Verified.	N/A	
There is sufficient vol. for all requested analyses, incl. any requested MS/MSDs	True	
Containers requiring zero headspace have no headspace or bubble is <6mm (1/4").	True	
Multiphasic samples are not present.	True	
Samples do not require splitting or compositing.	True	
Residual Chlorine Checked.	N/A	



**APPENDIX D. TIER 1 EAL SURFER SUMMARY REPORT**

# <sup>1</sup>Tier 1 EAL SURFER SUMMARY REPORT

## Hawai'i DOH (Fall 2017)

**Site Name:** KEKAHA WATER SYSTEM, KEKAHA, ISLAND OF KAUAI 96752  
**Site Address:** TMK (4) 1-2-002:039

**Site ID Number:**  
**Date of EAL Search:** 16-Aug-18

Selected Site Scenario	
<b>Land Use:</b>	Unrestricted
<b>Groundwater Utility:</b>	Drinking Water Resource
<b>Distance To Nearest Surface Water Body:</b>	< 150m

**Selected Chemical of Concern:** POLYCHLORINATED BIPHENYLS (PCBs)

Input Site Concentrations	
Soil (mg/kg):	6.35
Groundwater (ug/L):	-
Soil Vapor (ug/m <sup>3</sup> ):	-

Soil Environmental Hazards	Units	Tier 1 Action Level	<sup>2</sup> Potential Hazard?	<sup>3</sup> Referenced Table
<b>Direct Exposure:</b>	mg/kg	1.2E+00	Yes	Table I-1
<b>Vapor Emissions To Indoor Air:</b>	mg/kg	-	-	Table C-1b
<b>Terrestrial Ecotoxicity:</b>	mg/kg	site-specific	No	Table L
<b>Gross Contamination:</b>	mg/kg	5.0E+02	No	Table F-2
<b>Leaching (threat to groundwater):</b>	mg/kg	3.4E+01	No	Table E-1
<b>Background:</b>	mg/kg	-		
<b>Final Soil Tier 1 EAL:</b>		<b>mg/kg 1.2E+00</b>		
<b>Basis: Direct Exposure</b>				

Groundwater Environmental Hazards	Units	Tier 1 Action Level	<sup>2</sup> Potential Hazard?	<sup>3</sup> Referenced Table
<b>Drinking Water (Toxicity):</b>	ug/L	5.0E-01	-	Table D-1a
<b>Vapor Emissions To Indoor Air:</b>	ug/L	-	-	Table C-1a
<b>Aquatic Ecotoxicity:</b>	ug/L	1.4E-02	-	Table D-4a
<b>Gross Contamination:</b>	ug/L	2.2E+01	-	Table G-1
<b>Final Groundwater Tier 1 EAL:</b>		<b>ug/L 1.4E-02</b>		
<b>Basis: Aquatic Ecotoxicity</b>				

Other Tier 1 EALs:	Units	EAL	<sup>2</sup> Potential Hazard?	<sup>3</sup> Referenced Table
<b>Shallow Soil Vapor:</b>	ug/m <sup>3</sup>	9.9E+01	-	Table C-2
<b>Indoor Air:</b>	ug/m <sup>3</sup>	4.9E-02	-	Table C-3

**Notes:**

1. Include Surfer Summary Report in appendices of *Environmental Hazard Evaluation* (EHE) for contaminants that exceed Tier 1 EALs (refer to Chapter 3 of main text).
2. Environmental hazard could exist if concentration of contaminant exceeds action level.
3. Referenced tables presented in Appendix 1 of EHE guidance document.

HDOH 2017, Evaluation of Environmental Hazards at Sites with Contaminated Soil and Groundwater (Fall 2017): Hawai'i Department of Health, Hazard Evaluation and Emergency Response, <http://hawaii.gov/health/environmental/hazard/index.html>



Ken Hayashida, P.E. | President  
Michael Hunnemann, P.E. | Vice President

## **IFB Job No. 17-10**

# **Appendix N-Environmental Protection Agency Documents**

September 18, 2018

Ms. Sara Ziff, P.E.  
Project Manager  
Corrective Action Section  
U.S. Environmental Protection Agency, Region 9  
75 Hawthorne Street (LND-4-1)  
San Francisco, California 94105

**Subject: TSCA Risk-Based PCB Cleanup Approval Application  
Department of Water, Rehabilitate Paua Valley Tank #1  
Kekaha, Kauai, Hawaii**

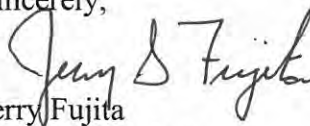
Dear Ms. Ziff:

KAI Hawaii, Inc. is pleased to submit the enclosed Risk-Based PCB Cleanup Approval Application for the Rehabilitation of the Paua Valley Tank #1. The Risk-Based PCB Cleanup Approval Application is submitted in accordance with the requirements of the Toxic Substances Control Act (TSCA, 40 CFR 761.61(c)) in order to obtain approval of the methods as described herein, to be used to discharge the PCB-containing storage water from the existing reservoir and to dispose of PCB waste.

The Risk-Based PCB Cleanup Approval Application includes information on the source, nature and extent of impact of the PCB-containing storage water and plans for removing and disposing of the PCB wastes. It also covers mitigation measures and a PCB monitoring plan to ensure that further PCB contamination is no longer a risk of injury to public health or to the environment.

Should you have any questions or require additional information, please contact me at (808) 791-3969 (direct office) or by email ([jfujita@kaihawaii.com](mailto:jfujita@kaihawaii.com)).

Sincerely,

  
Jerry Fujita  
KAI Hawaii, Inc.



# **RISK-BASED PCB CLEANUP APPROVAL APPLICATION**

## **For Rehabilitate Paua Valley Tank #1, 0.5 MG Concrete Kekaha, Kauai, Hawaii**



Prepared for:

United States Environmental Protection Agency  
Region 9  
Corrective Action Section

September 18, 2018

Prepared by:



50 South Beretania Street, Suite C-119C  
Honolulu, HI 96813

## **I. Introduction**

This Risk-Based PCB Cleanup Approval Application has been prepared for the County of Kauai Department of Water, Rehabilitation of the Paua Valley Tank #1. The Paua Valley Tank #1, 0.5 MG concrete reservoir is located in the State of Hawaii, in the Kekaha area on the island of Kauai (TMK (4) 1-2-002:039), and is accessed by a gated unpaved access road from Kokee Road. The reservoir site land is owned by the State of Hawaii with an Executive Order to the County of Kauai, Department of Water for well and water tank purposes. We estimate the reservoir was constructed in 1974 based on the signature dates on the original construction drawings, resulting in the estimated age of the reservoir being 43 years.

The reservoir has a nominal capacity of 500,000 gallons (0.5 MG) with an inside diameter of 69 feet and a maximum water height of 18 feet to the overflow pipe opening. The reservoir is cast-in-place conventionally reinforced concrete construction. The walls have a constant thickness for their full 20-foot height. The flat concrete roof slab is supported on the interior by four (4) square concrete columns. There is an exterior roof-access ladder with a fall protection system and a security shield at the bottom of the ladder to discourage unauthorized use.

The rehabilitation project proposed by the County of Kauai, Department of Water, will involve the repair of the concrete reservoir which includes interior and exterior work. The main concern prompting the request for rehabilitation of the reservoir was a water leak at the reservoir wall base. During the initial assessment of the condition of the reservoir, the water in the reservoir was drained and suspected hazardous material samples were collected from the interior and exterior of the reservoir. Samples of the coal tar lining at the interior floor and walls, and wall base joint sealant was taken and tested, and the results turned out positive for Polychlorinated Biphenyl (PCB). Subsequent to the initial assessment and after the reservoir had been refilled, an oily layer was found floating on the surface of the water. Samples of the oily layer was taken and also had been tested positive for PCB.

## **II. Purpose and Scope**

The purpose of this Risk-Based PCB Cleanup Approval Application (Application) is to request an approval of the methods as described herein, to be used to discharge the PCB-containing storage water from the existing reservoir and to dispose of PCB waste in a manner other than prescribed in 40 CFR 761.61(a) or (b), and to determine that these methods will not pose an unreasonable risk of injury to public health or the environment. This application includes information on the source, nature and extent of impact of the PCB-containing storage water and plans for removing and disposing of the PCB wastes.

As required by 40 CFR 761.61(a)(3)(e), copies of the certifications from the property owner, County of Kauai Department of Water, and responsible party conducting response actions, County of Kauai Department of Water, are provided in Appendix A.

### III. Relevant Contacts

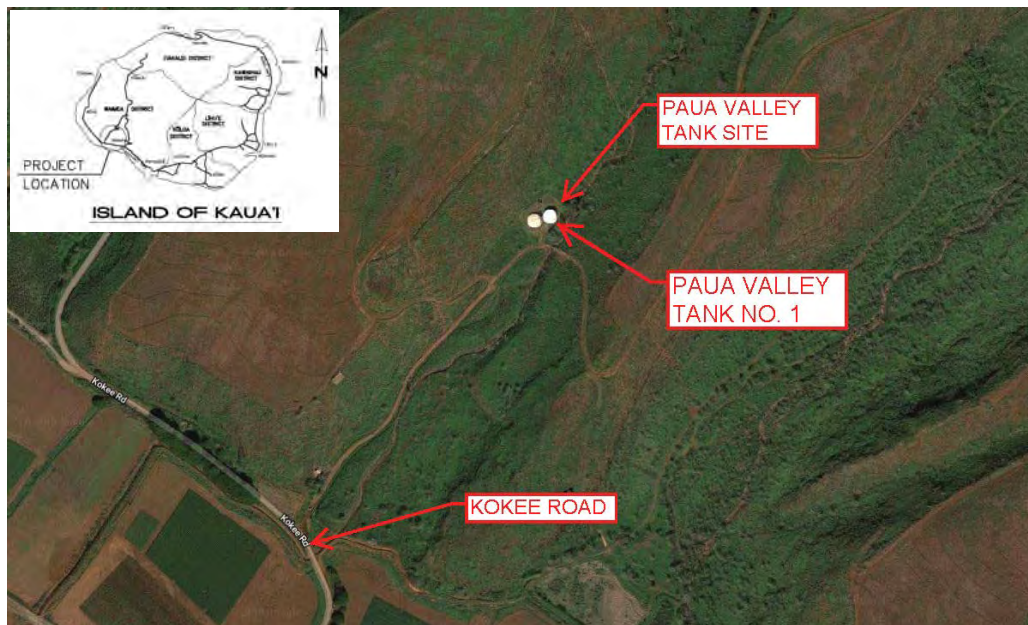
Owner: County of Kauai Department of Water  
Eric Fujikawa, Project Engineer  
4398 Pua Loke Street  
Lihue, Hawaii 96766  
Phone: (808) 245-5412

Consultants: KAI Hawaii, Inc.  
Jerry Fujita, Structural Engineer  
50 S. Beretania Street #C-119C  
Honolulu, Hawaii 96813  
Phone: (808) 791-3969

Myounghee Noh & Associates  
Myounghee Noh, Environmental Consultant  
99-1046 Iwaena Street, Suite 210A  
Aiea, Hawaii 96701  
Phone: (808) 484-9214

### IV. Site Description

The reservoir site is located on the Southwest side of the island of Kauai, in the slopes above the town of Kekaha. The site is occupied by two water reservoirs and a pump control building, and is enclosed by a site perimeter chain-link fence. The area outside of the site is open terrain, covered with vegetation. See Figure 1. This water system served about 5,800 people residing in the towns of Kekaha and Waimea (ehawaii.gov, 2017).



**Figure 1: Site Location Plan**

## Climate

Kekaha has a tropical climate. The site is located on the dry side of Kauai and receives 33 inches of rain annually (Mink & Lau, 1992). The average temperature is 75°F, with August being the hottest month averaging 78°F and January being the coolest month with an average of 72°F (Climate-Data, 2017).

## Soils/Geology

Kauai is the fourth largest and the oldest of the main Hawaiian Islands. It was formed from a single shield volcano that has been highly weathered and eroded to the point that the summit peak can be difficult to locate.

The age of Kauai has transformed much of its surface lava flows into weathered soils lending the island more erosional landforms versus the volcanic landforms found on the younger Hawaiian Islands (Morgan, 1996).

Mink and Lau (1992) describe the geology in the area as the following:

The region is a part of the southwest flank of the original volcano. Napali lavas terminate as a fossil sea cliff along a mile wide coastal plain of terrestrial and marine sediments. The Mana Plain is the most extensive and thickest accumulation of sediments in the island. Inland a few dikes have been mapped.

The United States Department of Agriculture Natural Resources Conservation Service classifies the soil at the tank site as Kekaha extremely stony silty clay loam with 0 to 35 percent slopes. Typically, this soil type is composed of extremely stony silty clay from 0 to 21 inches and clay from 21 to 70 inches. It is well-drained and more than 80 inches from the water table. Soil to the west of the drainage ditch are classified as Waiawa extremely rocky clay with 30 to 80 percent slopes. This soil type is typically composed of clay from 0 to 14 inches, and bedrock from 14 to 24 inches. It is well drained and is generally 6 to 15 inches to lithic bedrock (United States Department of Agriculture, 2008).

## Surface Water

Mink and Lau (1992), describe the hydrogeology in the area as the following:

Having an average rainfall of just 33 inches, Kekaha is the driest Aquifer System in Kauai. Surface drainage is by way of small, non-perennial streams that debouch onto the Mana Plain. The Plain originally was a vast swamp but is not artificially drained to allow cropping.

The tank is located adjacent to a dry streambed and provides the drainage ditch for the tank. During previous site visits, there were no indications of water flow in the stream. The stream likely flows during times with heavy rainfall.

## Groundwater

The HDOH Safe Drinking Water Branch established an Underground Injection Control (UIC) line to serve as a boundary between drinking water and non-drinking water portions of aquifers. Areas above (mountain side) the UIC line are within drinking water portions of the aquifer, while areas below (ocean side) the UIC line are in non-drinking water portions of the underlying aquifer. The subject property is above the UIC line in a drinking water portion of the aquifer (Hawaii Department of Health Safe Drinking Water Branch, 2014).

The hydraulic gradient, and therefore the expected direction of travel, of the basal groundwater within the basaltic formation is, in general, from mountain areas to the shoreline. According to Mink and Lau (1992), the tank site is located above the Kekaha Aquifer System of the Waimea aquifer sector and described the groundwater at the aquifer as follows:

High-level dike aquifers may occur in Napali lavas in the interior near the Waimea Canyon divide. Otherwise the flank lavas contain basal groundwater. The Napalia aquifer beneath the Mana Plain cap rock is artesian. This aquifer has been developed as a source of irrigation supply. The sediments are saturated with brackish to salty water. Upward leakage into the sediments from the Napali artesian aquifer is the cause of the original swamp conditions. When artificial drainage for the Plain ceases, it will again become a swamp. Potable water is developed from the wells near Kekaha and Waimea. These wells are located at the inland edge of the Plain.

## Current/Future Land Use

The current land use of the site is for water storage tanks that previously serviced the Kekaha and Waimea areas. The future land use will remain the same; no future development at the site is expected.

## **V. Pre-Cleanup Site Characterization**

During the initial assessment of the condition of the reservoir, the water in the reservoir was drained and suspected hazardous material samples were collected from the interior and exterior of the reservoir. Samples of the coal tar lining at the interior floor and walls, and wall base joint sealant was taken and tested for PCB, and had results up to 283 ppm. See the Hazardous Material Survey Report in Appendix B.

After the reservoir was refilled, an oily layer floating at the top of the water surface was noticed. The oily layer was sampled for PCB and the result was 13 µg/L (ppb). The water in the tank was also sampled at the entry point to the water system, and the result was not detected (i.e., less than or equal to the method detection limit of 0.1 ppb).

It is currently known that the extent of the PCB contamination is within the concrete reservoir and within the Paua drainage ditch outside of the subject property, see Figure 2. PCB mitigation for contaminated soils within the Paua drainage ditch is outside the scope of this Application. The reservoir is currently off-line.

## VI. PCB Cleanup Plan

### BACKGROUND:

Currently the reservoir contains approximately 0.35 MG of water with detected PCB concentrations at 0.013 mg/L (13  $\mu\text{g/L}$ ) on the water surface in excess of the 0.0005 mg/L (0.5  $\mu\text{g/L}$ ) allowable limit for potable water. The water from the effluent line drawn from the bottom of the reservoir does not have any detected PCB concentration.

### DISCHARGE LOCATION AND SCHEDULE:

1. The water in the reservoir will be discharged into the Paua drainage ditch, see Figure 2, at a rate to allow the discharged water to infiltrate into the ground surface before reaching approximately 200 feet downstream of the reservoir discharge pipe. It is expected that the discharge rate will be about 14,000 gallons/day for 25 days. See photos below for areas to receive the discharged reservoir water.



**Figure 2: Enlarged Site Location Plan**



**Photo 1: Reservoir discharge outlet**



**Photo 2: Paua Drainage Ditch**



**Photo 3: Paua Drainage Ditch**

## DISCHARGE PROCEDURE AND SAMPLING PLAN:

1. Test water at effluent line sampling tap which draws water from the bottom region of the reservoir water to confirm the PCB-concentration is within allowable limit to allow water to be discharged without any filtration. Consult with USEPA and HDOH about PCB concentration and obtain approval to discharge. EPA Method 505 will be used for water testing. The required sample container per sample is two (2) one-liter glass amber bottle. Recommend collecting two samples for field quality control.
2. If the PCB concentration in water from Step 1 is below allowable upper limit (0.5 µg/L), SLOWLY discharge water from the reservoir cleanout drain line to minimize the mixing of the water with the PCB-containing “scum” layer on the water surface. Drain continuously at a slow rate until the water level reaches a depth of approximately 2 feet.
3. Connect piping at end of drainage discharge pipe from reservoir by removing flap gate valve and connect two liquid phase absorber unit drums containing virgin activated carbon 8 x 12 mesh design to absorb PCB. The discharge rate for two units connected in parallel is 10 gallons per minute. This absorber unit drum is a manufactured assembly and can be purchased from the manufacturers listed below. Release as much water as will drain by gravity. The remaining residue will be left for the project contractor to clean up as part of the interior coating removal work.

Activated Carbon Filter Drum: A liquid phase activated carbon adsorption system for environmental remediation and institutional water conditioning applications. Contained in a steel drum is 150-200 pounds of virgin activated carbon capable of handling a flow of at least 10 gpm, with a maximum operating pressure of 6 psi. This manufactured assembly can be purchased from the following manufacturers:

- a. “Econosorb-LS”, by TIGG Corporation, 1 Willow Avenue, Oakdale, PA, Phone: (724) 703-3020, [www.tigg.com](http://www.tigg.com).
  - b. “Water Purification Canister L-1”, by Carbtrol Corporation, 955 Connecticut Ave., Suite 5202, Bridgeport, CT 06607, Phone: (800) 242-1150, [www.carbtrol.com](http://www.carbtrol.com).
4. Take a follow-up effluent water sample, discharged from the activated carbon filter units to confirm the PCB-concentration is below the allowable limit, 0.5 µg/L, and analyze using EPA Method 505. The required sample container per sample is 2 x 1L glass amber. If the PCB result is greater than 0.5 µg/L, the Contractor shall stop discharging water and replace granular activated carbon or add an additional treatment such as bag filters with 0.5 µm after carbon filtration. Repeat this step until the PCB concentration is below the allowable limit.
  5. Perform Toxicity Characteristic Leaching Procedure (TCLP) analysis, Method 1311, on the activated carbon filter drum units to determine if the waste is hazardous or



non-hazardous. If PCB concentration is determined to be less than 50 ppm, the activated carbon filter drum units can be disposed of at the municipal landfill with no special requirements after all the water has been filtered.

6. If the PCB concentration is determined to be greater than 50 ppm, dispose of the activated carbon filter drum units as permitted by State, and Federal law based on the PCB concentration of the surface filter material, absorbent and carbon filter testing.
7. EPA will issue an approval document per TSCA requirements for the disposal of the oil-soaked absorbent pad based on the requested test results obtained along the process.

#### SAMPLE COLLECTION AND LABORATORY ANALYSIS:

Collected samples shall be stored between 0 - 4 °Celsius until the samples are delivered to the laboratory. The samples shall be stored at the required temperature immediately after collection to preserve the condition at the time of collection. The sampler shall coordinate further with an analytical laboratory to confirm the testing method, sample amount, and sample preservation requirements.

### **VII. Mitigation and Monitoring Plan after Reservoir Repair**

Following the water discharge and disposal activities, the rehabilitation of the existing reservoir will continue with the removal of the existing interior coating and installation of a new interior coating system of the floor, pipe exterior, wall, and column surfaces. The interior coating system will be NSF 61 certified and be installed following quality control procedures with applicable ASTM, NACE, and SSPC standards and the protective coating manufacturer's recommendation. The new coating system will cover all existing surfaces that was once in contact with PCB.

After the interior recoating and refilling of the reservoir with water, and prior to placing the reservoir back in service, the Department of Water will sample and test the water at the discharge point to the distribution system for PCB. Following confirmation that PCB is undetectable, the reservoir shall be placed back in service. The Department of Water will sample and test the water using EPA Method 505 on a quarterly basis for three (3) quarters. If PCB is still at non-detectable levels for that period of time, sampling will continue on an annual basis. Sampling and testing operations may cease upon confirmation that PCB concentrations are at non-detectable levels for the next three (3) consecutive years.

# APPENDIX A

## Certifications

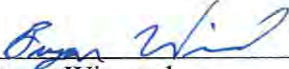
**Responsible Party Certification**

Risk-Based PCB Cleanup Approval Application  
County of Kauai Department of Water  
Lihue, Hawaii

As the party responsible for conducting the proposed cleanup described in the Risk-Based PCB Cleanup Approval Application, County of Kauai Department of Water certifies that all sample collection procedures, laboratory analysis, and discharging procedures used to characterize the PCB contamination at the Site are on file at the following location for EPA inspection:

County of Kauai Department of Water  
4398 Pua Loke Street  
Lihue, Hawaii 96766

To access these files, contact Bryan Wienand at (808) 245-5408, to schedule an appointment and identify specific records to be inspected. The Department of Water will compile the information requested and make the information available for review in our office or transmit copies directly to the EPA representative requesting the information.

  
\_\_\_\_\_  
Bryan Wienand  
Manager and Chief Engineer  
County of Kauai Department of Water

9/13/18  
Date

**Property Owner Certification**

Risk-Based PCB Cleanup Approval Application  
County of Kauai Department of Water  
Lihue, Hawaii

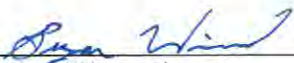
The Risk-Based PCB Cleanup Approval Application describes response actions that will be conducted on the following property:

County of Kauai Department of Water  
Pua Valley Tank Site  
Kekaha, Hawaii 96752  
TMK: (4) 1-2-002:039

As the owner of the property where remedial actions will be conducted described in the Risk-Based PCB Cleanup Approval Application certifies that all sample collection procedures, laboratory analysis, and discharging procedures used to characterize the PCB contamination at the Site are on file at the following location for EPA inspection:

County of Kauai Department of Water  
4398 Pua Loke Street  
Lihue, Hawaii 96766

To access these files, contact Bryan Wienand at (808) 245-5408, to schedule an appointment and identify specific records to be inspected. The Department of Water will compile the information requested and make the information available for review in our office or transmit copies directly to the EPA representative requesting the information.

  
\_\_\_\_\_  
Bryan Wienand  
Manager and Chief Engineer  
County of Kauai Department of Water

9/13/18  
\_\_\_\_\_  
Date

APPENDIX B  
Hazardous Material Survey Report

---

**HAZARDOUS MATERIAL SURVEY REPORT  
FOR  
REPAIRS TO KEKAHA 0.5 MG CONCRETE STORAGE TANK  
COUNTY OF KAUAI DEPARTMENT OF WATER  
KEKAHA WATER SYSTEM  
KEKAHA, ISLAND OF KAUAI 96752**

**TMK (4) 1-2-002:039**

**MNA PROJECT 2388\_3**

**DECEMBER 14, 2017**



**Myounghee Noh & Associates**

**Environmental Studies and Consulting Services**

200 Kohola Street, Hilo, Hawaii, USA 96720 • 808.935.8727  
99-1046 Iwaena Street, Suite 210A, Aiea, Hawaii, USA 96701 • 808.484.9214

---

This report is prepared for:

KAI Hawaii, Inc.  
50 S. Beretania Street, #C-119C  
Honolulu, Hawaii 96813

**HAZARDOUS MATERIAL SURVEY REPORT**  
**FOR**  
**REPAIRS TO KEKAHA 0.5 MG CONCRETE STORAGE TANK**  
**COUNTY OF KAUAI DEPARTMENT OF WATER**  
**KEKAHA WATER SYSTEM**  
**KEKAHA, ISLAND OF KAUAI 96752**

TMK (4) 1-2-002:039

MNA Project 2388\_3

December 14, 2017



Akari Ihara  
Building Inspector  
(HI Cert. HIASB-1014, Exp. 04/20/2018)



Jessica Walsh  
Report Writer



Myounghee Noh, CIH  
Principal

Myounghee Noh & Associates, L.L.C.  
Environmental Studies and Consulting Services  
99-1046 Iwaena Street, Suite 210A, Aiea, HI 96701  
Tel (808) 484-9214  
[www.noh-associates.com](http://www.noh-associates.com)

**TABLE OF CONTENTS**

**EXECUTIVE SUMMARY.....iv**

**1.0 INTRODUCTION..... 1**

**2.0 SAMPLING AND SURVEY METHODS ..... 1**

    2.1 Identifying Homogeneous Materials..... 3

    2.2 Building Material Sampling ..... 3

**3.0 LABORATORY INFORMATION ..... 4**

**4.0 ASBESTOS RESULTS..... 4**

**5.0 LEAD RESULTS..... 6**

**6.0 ARSENIC RESULTS ..... 7**

**7.0 SUSPECT PCB-CONTAINING BULK MATERIAL RESULTS ..... 7**

**8.0 SUMMARY OF SURVEY RESULTS ..... 8**

**9.0 RECOMMENDATIONS FOR RENOVATION AND CONSTRUCTION WORK ..... 9**

    9.1 Asbestos-Containing Materials ..... 9

    9.2 Lead-Containing Paints..... 11

    9.3 Arsenic-Containing Materials ..... 12

    9.4 PCB-Containing Bulk Materials ..... 12

**10.0 LIMITATIONS ..... 14**

**FIGURE**

Figure 1. Vicinity Map..... 2

**TABLES**

Table 1. Summary of Sampling and Results..... 3

Table 2. Asbestos-Containing Material Determination ..... 5

Table 3. Lead-Containing Paint Determination..... 6

Table 4. Bulk PCB Determination..... 7



## **APPENDICES**

- Appendix A Inspector Certifications
- Appendix B Homogeneous Materials Identified and Sample Types Collected
- Appendix C Sample and Hazardous Material Location Drawings
- Appendix D Photographs
- Appendix E Laboratory Analytical Reports

## **CONTRIBUTORS**

Project Manager	Akari Ihara
Certified Inspectors	Akari Ihara, Danny Falanug
Data QC	Kristin Cabanila
Drafter/Illustrator	Kristin Cabanila
Report Writer	Jessica Walsh
Editor/QC	Akari Ihara

## EXECUTIVE SUMMARY

In July 2017, Myounghee Noh & Associates, L.L.C. (MNA), was retained by KAI Hawaii, Inc., to conduct a hazardous material survey at the County of Kauai Department of Water (DOW) Paua Valley 0.5 MG concrete water tank located at Tax Map Key (TMK) (4) 1-2-002:039, Kekaha, Kauai. The survey targeted building materials in and on the 0.5 MG water tank; the second tank on the parcel was a metal water tank and was not included in the survey.

The objective of the survey was to identify the existence (if any), extent, and condition of hazardous materials present in and on the tank, so that the information can be incorporated in the rehabilitation design.

On August 17, 2017, MNA conducted this hazardous material survey and identified a total of 19 suspect building materials. On October 19, 2017, MNA collected additional bulk samples from the black coating on the interior wall of the tank for analysis of PCB and asbestos content, at the request of the State of Hawaii Department of Health Safe Drinking Water Branch. Based on the analysis of 21 asbestos bulk samples, 12 lead paint chip samples, and 12 polychlorinated biphenyls (PCB) bulk samples, MNA provides the following summary:

- No regulated asbestos-containing materials (ACM) were identified during the survey. One material, **beige coating** in poor condition **on concrete floor** contained 0.25% asbestos. This level of asbestos is considered a trace amount. While the less than 1% asbestos is not a regulated material, airborne fibers in unventilated space can be a respiratory hazard.
- Four lead-containing paints (LCP) were identified in the project area:
  - **Light blue paint** in fair condition, **710 milligrams per kilogram (mg/kg)** and **1,200 mg/kg, on exterior concrete roofing system**, approximately 2,000 square feet.
  - **Light green paint** in fair condition, **1,200 mg/kg** and **1,400 mg/kg, on exterior metal handrail and ladder**, approximately 20 linear feet.

Two of the identified LCP were lead-based paint (LBP), exceeding 5,000 mg/kg, as follows:

- **Dark green paint** in fair condition, **41,000 mg/kg** and **55,000 mg/kg, on exterior metal hatch**, approximately 5 square feet.
- **Beige paint** in poor condition, **40,000 mg/kg** and **41,000 mg/kg, on interior concrete floor**, approximately 5,000 square feet.
- No suspect arsenic-containing materials were identified in the project area.
- Three PCB-containing materials were identified in the concrete water tank:
  - **Beige coating** in poor condition, **28.4 mg/kg (total PCB congeners), on interior concrete floor and debris**, approximately 5,000 square feet.
  - **Beige asphaltic base sealant** in fair condition, **10.5 mg/kg (total PCB congeners), on interior concrete joint**, approximately 220 square feet.

- **Black coating** in poor condition, **283 mg/kg (total PCB congeners) based on confirmation sampling, on interior concrete wall**, approximately 4,840 square feet.

No suspected hazardous materials were identified on the tank access road, which is slated for re-paving as part of this project.

Based on the visual survey and sampling and analysis of suspect bulk materials and paints, special hazard control measures are warranted for work involving lead-containing paint (LCP), lead-based paint (LBP), and PCB-containing material. These control measures are briefly described in Section 9 Recommendations for Renovation and Construction Work. General dust and runoff controls are also warranted.

The contractor must verify the location and volumes of potentially hazardous materials and determine the appropriate dust and hazard control measures based on the area and material to be disturbed. Quantities of materials provided in this report are based on visual approximations only during the survey and should not be used for bidding purposes.

## 1.0 INTRODUCTION

Myounghee Noh & Associates, L.L.C. (MNA), under an agreement with KAI Hawaii, Inc., conducted a hazardous material survey for the County of Kauai Department of Water (DOW) Paua Valley 0.5 MG Tank located at Tax Map Key (TMK) (4) 1-2-002:039, Kekaha, Kauai.

MNA's survey was conducted in support of the planned concrete water tank repair and rehabilitation project. The building materials on the DOW 0.5MG Tank were assessed; the second tank on the parcel was a metal tank and was not part of the survey. The survey targeted the following materials:

- Hazardous building materials due to the suspected presence of asbestos, lead, or arsenic.
- Suspect polychlorinated biphenyls (PCB)-containing tank liner material.



Kauai County DOW 0.5MG Tank  
August 2017

## 2.0 SAMPLING AND SURVEY METHODS

During August 17 and October 19, 2017, State of Hawaii-certified building inspectors, Akari Ihara and Danny Falanug, conducted the hazardous material survey. The inspectors performed a visual assessment of the interior and exterior of the tank, identified materials suspected of containing asbestos, lead, arsenic, or PCB, and collected samples of these materials. Inspector certifications are presented in Appendix A.

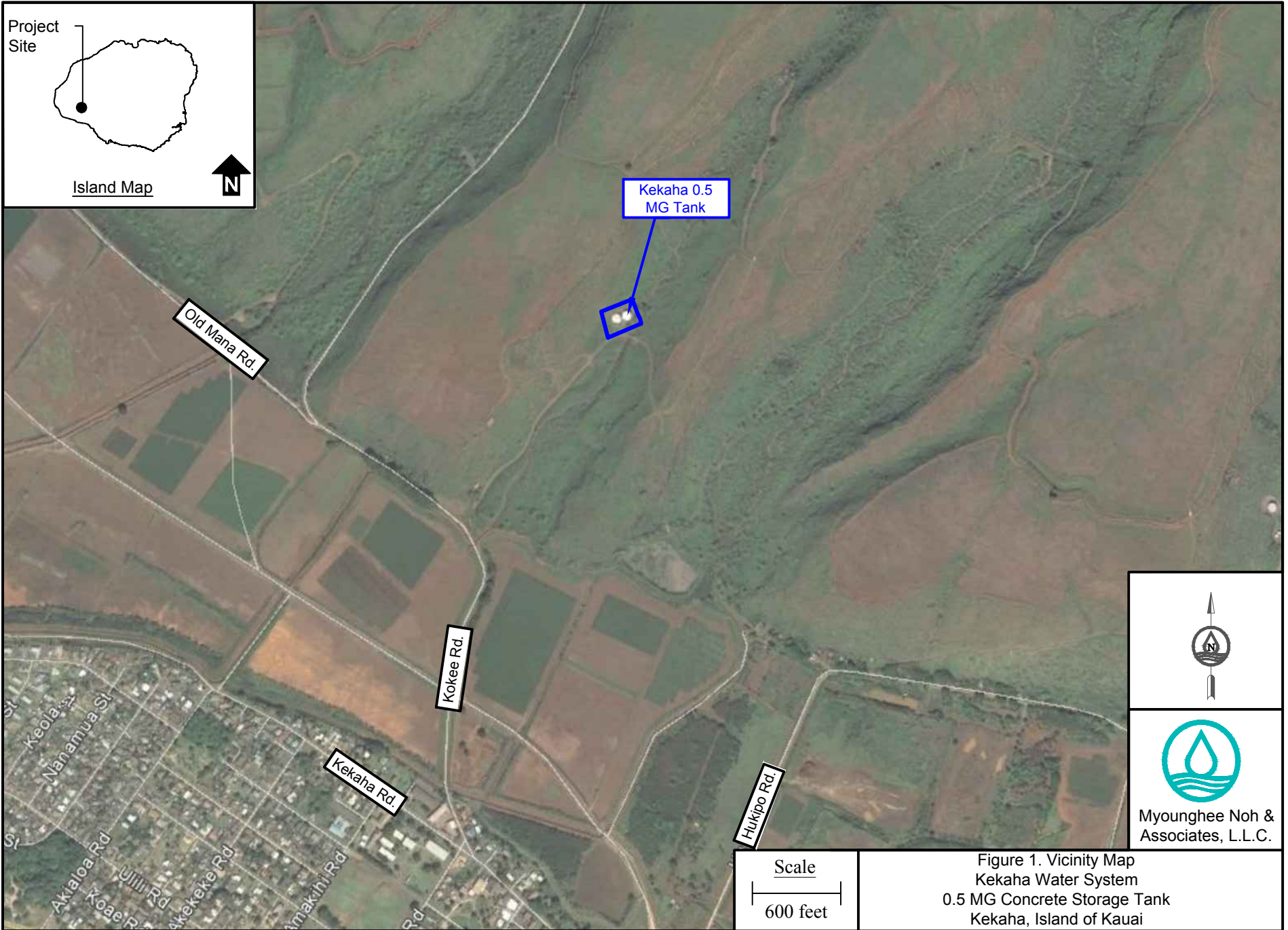


Figure 1. Vicinity Map  
 Kekaha Water System  
 0.5 MG Concrete Storage Tank  
 Kekaha, Island of Kauai

## 2.1 Identifying Homogeneous Materials

The inspectors identified building materials with the same appearance, color, and substrate as homogeneous materials. Interior homogeneous materials are considered unique per building and building floor, while exterior building materials are considered unique per building. Building materials with the same characteristics (appearance, color, and substrate), as an identified homogeneous material, should be considered to possess the same hazard characteristics, unless specifically identified as otherwise in the report. As an example, if dark green paint on metal is found to be lead-based paint (LBP), then all identical dark green paint on metal in the survey area should be treated as LBP. Table 1 provides an overview of sampling and a summary of hazardous materials identified.

**Table 1. Summary of Sampling and Results**

Materials Sampled	Samples Submitted/Inspected	Suspect Material Locations	Identified Hazardous Materials
<b>Paua Valley 0.5 MG Concrete Water Tank</b>			
Asbestos in bulk material or paint	21	Floor, roofing system, sealant joint, vent, walls	1 Material containing trace asbestos*
Lead in paint	10	Floor, handrail, hatch, ladder, roofing system, walls	4 LCP (710 mg/kg – 55,000 mg/kg) including 2 LBP (40,000 mg/kg – 55,000 mg/kg)
Arsenic in bulk material	0	--	None
PCB in bulk material	12	Debris, floor, sealant joint, walls	3 PCB-containing tank liner materials (10.5 mg/kg – 283 mg/kg Total PCB)

\* Trace indicates that one or more asbestos fibers were detected by the point count method. While the less than 1% asbestos is not a regulated material, OSHA considers the trace amount as a health concern.

LBP – Lead-Based Paint,  $\geq 5,000$  mg/kg

LCP – Lead-Containing Paint,  $< 5,000$  mg/kg

mg/kg – milligrams per kilogram (equivalent to parts per million)

PCB – Polychlorinated biphenyls

## 2.2 Building Material Sampling

Bulk and paint samples were collected using a decontaminated chisel, razor, or hammer in a manner that minimized airborne dust. The inspector collected triplicate samples for asbestos and PCB-containing tank liner material and duplicate samples for lead. Additional confirmation sampling was conducted for the tank liner material. No suspected arsenic-containing building materials were identified. Samples were placed in sealable plastic bags, labeled with a unique identification number, and recorded on a chain-of-custody. For each sample, the date, sample appearance, analyte, and sample location were recorded on a field data form. Asbestos and PCB samples were transported under chain-of-custody to LA Testing in South Pasadena, California.

LA Testing utilized its sister company EMSL Analytical, Inc., in Cinnaminson, New Jersey, to analyze the PCB samples. Lead samples were transported under chain-of-custody to Hawaii Analytical Laboratory, LLC, in Honolulu, Hawaii.

### **3.0 LABORATORY INFORMATION**

LA Testing analyzed the asbestos samples by polarized light microscopy using the Environmental Protection Agency (EPA) Method 600/R-93/116. LA Testing, South Pasadena, is certified by:

- National Voluntary Laboratory Accreditation Program (NVLAP), certification 200232-0
- State of Hawaii Department of Health (HDOH), certification L-01-034
- American Industrial Hygienist Association (AIHA) Environmental Lead Laboratory Accreditation Program (ELLAP), certification 102814

Hawaii Analytical Laboratory analyzed the lead samples by flame atomic absorption spectroscopy using the EPA Method 7082m. Hawaii Analytical Laboratory, Honolulu, is certified by:

- NVLAP, certification 200655-0
- HDOH, certification L-14-002
- AIHA ELLAP, certification 101812

EMSL Analytical analyzed the PCB samples by gas chromatography using the EPA Method 3540C/8082A. EMSL Analytical, Cinnaminson, is certified by the New Jersey Environmental Laboratory Accreditation Program (ELAP), certification 03036.

### **4.0 ASBESTOS RESULTS**

Materials determined to contain greater than, or equal to, 1% asbestos are considered regulated asbestos-containing material (ACM) under the National Emission Standards for Hazardous Air Pollutants (NESHAP) as specified in 40 Code of Federal Regulations (CFR) Part 61 Subpart M. The U.S. Occupational Safety and Health Administration (OSHA) Asbestos General Industry and Construction Standards also define ACM as 1% asbestos or more by volume under 29 CFR 1910.1001 and 29 CFR 1926.1101, respectively. However, any measurable levels of asbestos fibers are considered to be a health concern.

Six homogeneous materials suspected of containing asbestos were identified and sampled, generating 18 samples for analysis. However, none of the samples contained 1% or greater asbestos by volume. Therefore, it is concluded that no regulated ACM are present in the area anticipated to be disturbed (Table 2).

One material (HM 7, beige cement material on interior concrete floor) contained less than 1% asbestos, and was therefore subjected to a point count analysis. Laboratory point count analytical results for this material indicated trace amounts of asbestos, less than 0.25% asbestos, and is not classified as ACM. The term “trace” indicates that one or more asbestos fibers were detected by the point count method. While the less than 1% asbestos is not a regulated material, airborne fibers in unventilated space can be a respiratory hazard and health concern.

Due to the <1% results, an additional triplicate confirmation sample was collected for the black coating on the inner concrete wall (HM ID 9). It was verified that the coating material contained no measurable amount of asbestos, but there was insufficient volume of concrete in the sample to verify asbestos level in the concrete wall. This material should be sampled prior to disturbance.

The suspected ACM descriptions and identifiers are provided in Appendix B. Sample location drawings are provided in Appendix C. Photographs of suspected materials are presented in Appendix D. Laboratory analytical reports, chain-of-custody, and field data forms are provided in Appendix E.

**Table 2. Asbestos-Containing Material Determination**

Locations	HM ID	Material Color	Material	Substrate	Result	Condition	Estimated Quantity
Roofing system	2	Lt. blue	Paint/skim coat	Concrete	ND	Fair	3,850 sq. ft.
Roof vent	3	Gray	Cement board	Concrete	ND	Fair	105 ln. ft.
Exterior wall	11	Orange	Paint/skim coat	Concrete	ND	Poor	4,840 sq. ft.
Tank floor	7	Beige	Coating Cement material	Concrete	ND <0.25%*	Poor	3,850 sq. ft.
Tank interior Sealant joint	8	Beige	Coating Texture Tar	Concrete	ND	Fair	220 sq. ft.
Tank interior wall	9	Black	Coating	Concrete	ND	Poor	4,850 sq. ft.
Tank interior wall	9C1	Black	Coating	Concrete	ND	Poor	4,850 sq. ft.

\* Indicates presence of materials containing trace asbestos. “Trace” means that one or more asbestos fibers were detected by the point count method. While the less than 1% asbestos is not a regulated material, OSHA considers the trace amount as a health concern.



Fair – Material is functional for its installed purpose but shows initial signs of deterioration beyond the cosmetic.  
Poor – Material shows significant deterioration and may not be functional for its installed purpose. The binding of the material has decreased integrity as indicated by peeling, cracking, or crumbling of the material.

Abbreviations and Acronyms

HM ID – Homogeneous Material Identifier                      ND – Not Detected  
In. ft. – Linear Feet    sq. ft. – Square Feet

**5.0 LEAD RESULTS**

The U.S. Department of Housing and Urban Development (HUD) and the EPA define paint containing 5,000 milligrams per kilogram (mg/kg), or 0.5% by weight, or more of lead to be LBP. OSHA and the State of Hawaii consider paint containing any measurable concentration of lead to be lead-containing paint (LCP) and a health concern. When lead is detected in a multi-layer sample, it is assumed that all layers represented by the sample contain lead at the same concentration.

Five suspected lead paints were identified and sampled, generating 10 paint chip samples. Four LCP were identified in the survey area, with sample results ranging from 710 mg/kg to 55,000 mg/kg. Two of those LCP were identified as LBP, exceeding 5,000 mg/kg, the threshold for LBP (Table 3).

Suspected LCP descriptions and identifiers are provided in Appendix B. Sample and hazardous material location drawings are in Appendix C. Photographs of suspected LCP are presented in Appendix D. Laboratory analytical reports, chain-of-custody, and field data forms are provided in Appendix E.

**Table 3. Lead-Containing Paint Determination**

Locations	HM ID	Material Color	Material	Substrate	Result (mg/kg)	Condition	Estimated Quantity
Roofing system	1	Lt. blue	Paint	Concrete	LCP 710 - 1,200	Fair	3,850 sq. ft.
Roof hatch	4	Dk. green	Paint	Metal	<b>LBP 41,000 - 55,000</b>	Fair	10 sq. ft.
Exterior handrail, ladder	5	Lt. green	Paint	Metal	LCP 1,200 - 1,400	Fair	90 ln. ft.
Exterior wall	10	Orange	Paint	Concrete	<40	Poor	4,840 sq. ft.
Exterior wall	12	Beige	Paint	Concrete	<40	Poor	2,420 sq. ft.
Interior Floor	6	Beige	Coating	Concrete	<b>LBP 40,000 - 41,000</b>	Poor	3,850 sq. ft.

**Bold values indicate results above the reporting limit.**

Fair – Material is functional for its installed purpose but shows initial signs of deterioration beyond the cosmetic.

Poor – Material shows significant deterioration and may not be functional for its installed purpose. Paint is bubbling or peeling over 20% or more of surface area and no longer protects the substrate.

**Abbreviations and Acronyms**

HM ID – Hazardous Material Identifier  
LBP – Lead-Based Paint, ≥5,000 mg/kg  
LCP – Lead-Containing Paint, <5,000 mg/kg

ln. ft. – Linear Feet  
mg/kg– milligrams per kilogram or parts per million  
sq. ft. – Square Feet

**6.0 ARSENIC RESULTS**

The disturbance of arsenic-containing materials is regulated by the OSHA Inorganic Arsenic General Industry Standard under 29 CFR 1910.1018. No suspected arsenic-containing materials were observed; therefore, no samples were collected during this survey.

**7.0 SUSPECT PCB-CONTAINING BULK MATERIAL RESULTS**

The storage and disposal of PCB-containing materials is regulated by the Toxic Substances Control Act (TSCA) PCB Regulations under 40 CFR 761 Subpart D. Three tank lining materials suspected of containing PCB were identified and sampled, generating 12 samples (nine primary and three confirmation) for analysis. All three materials were identified as PCB-containing, with total PCB concentrations ranging from 10.5 mg/kg to 283 mg/kg.

PCB-containing material descriptions and identifiers are provided in Appendix B. Sample and hazardous material location maps are provided in Appendix C. Photographs of suspect materials are provided in Appendix D. Laboratory analytical reports, chains of custody, and field data forms are provided in Appendix E.

**Table 4. Bulk PCB Determination**

Locations	HM ID	Material Color	Material	Substrate	Result (mg/kg)	Estimated Quantity (sq. ft.)
Inside tank floor bottom, debris	13	Beige	Coating	Concrete	Aroclor-1016, 1221, 1232, 1248: ND <b>Aroclor-1242: 2.3</b> <b>Aroclor-1254: 8.1</b> <b>Aroclor-1260: 18</b> Aroclor-1262: ND <u>Aroclor-1268: ND</u> <b>Total PCB: 28.4</b>	3,850
Inside tank sealant joint	14	Beige	Asphaltic base sealant	Concrete	Aroclor-1016, 1221, 1232, 1248: ND <b>Aroclor-1242: 2.4</b> <b>Aroclor-1254: 3.4</b> <b>Aroclor-1260: 4.7</b> Aroclor-1262: ND <u>Aroclor-1268: ND</u> <b>Total PCB: 10.5</b>	220

Locations	HM ID	Material Color	Material	Substrate	Result (mg/kg)	Estimated Quantity (sq. ft.)
Inside tank wall	15	Black	Coating	Concrete	Aroclor-1016, 1221, 1232, 1242, 1248: ND <b>Aroclor-1254: 38</b> <b>Aroclor-1260: 76</b> Aroclor-1262: ND <u>Aroclor-1268: ND</u> <b>Total PCB: 114</b>	4,840
	15C1				Aroclor-1016, 1221, 1232, 1242, 1248: ND <b>Aroclor-1254: 73</b> <b>Aroclor-1260: 210</b> Aroclor-1262: ND <u>Aroclor-1268: ND</u> <b>Total PCB: 283</b>	
	15C2				Aroclor-1016, 1221, 1232, 1242, 1248: ND <b>Aroclor-1254: 51</b> <b>Aroclor-1260: 170</b> Aroclor-1262: ND <u>Aroclor-1268: ND</u> <b>Total PCB: 221</b>	
	15C3				Aroclor-1016, 1221, 1232, 1242, 1248: ND <b>Aroclor-1254: 39</b> <b>Aroclor-1260: 170</b> Aroclor-1262: ND <u>Aroclor-1268: ND</u> <b>Total PCB: 209</b>	

**Bold values indicate results above the reporting limit.**

All three tank liner materials were identified to be in poor condition, indicating that the material shows significant deterioration and may not be functional for its installed purpose.

HMs 15C1, 15C2, and 15C3 are confirmation samples for HM 15, black coating on interior concrete tank walls.

**Abbreviations and Acronyms**

HM ID – Hazardous Material Identifier  
mg/kg – milligrams per kilogram or parts per million  
ND – Not Detected

PCB – Polychlorinated Biphenyls  
sq. ft. – Square Feet

**8.0 SUMMARY OF SURVEY RESULTS**

MNA conducted a hazardous material survey at the County of Kauai DOW Paua Valley 0.5 MG Tank located in Kekaha, Kauai. MNA’s survey was conducted in support of the tank repair and rehabilitation project. The second tank located on the same parcel was not included in the scope of work for this project. No suspected or confirmed hazardous materials were identified on the tank access road that is slated for repaving as part of this project.

Based on the analysis of 21 asbestos samples, 10 lead samples, and 12 PCB coating samples, MNA provides the following summary:

**Summary of Hazardous Material Findings**

	ACM	LCP	LBP	ArCM	PCB
<b>COUNTY OF KAUAI DOW 0.5MG TANK</b>					
Interior	*		☐		☐
Exterior		☐	☐		

☐ indicates presence of hazardous material

\* Indicates presence of materials containing trace asbestos. “Trace” means that one or more asbestos fibers were detected by the point count method. While the less than 1% asbestos is not a regulated material, OSHA considers the trace amount as a health concern.

ACM – Asbestos-Containing Material

LCP – Lead-Containing Paint, <5,000 mg/kg

ArCM – Arsenic-Containing Material

PCB – Polychlorinated Biphenyls

LBP – Lead-Based Paint, ≥5,000 mg/kg

**9.0 RECOMMENDATIONS FOR RENOVATION AND CONSTRUCTION WORK**

It is required that properly trained employees perform construction work and renovation that disturbs hazardous materials, in a manner protective of the site workers, facility users, and the environment. The following recommendations address OSHA and other applicable federal requirements. These recommendations provide guidance for the management of hazardous building materials and control of occupational and environmental hazards associated with operations, maintenance, renovation, and demolition. These recommendations are based on information gathered during the hazardous materials survey. These recommendations are not intended to constitute a formal work plan but are intended to provide a starting point for the development of a work plan or procedure.

**9.1 Asbestos-Containing Materials**

Employees involved in renovation or demolition activities that disturb materials containing trace amounts of asbestos must conduct work in accordance with 29 CFR 1926.1101, the OSHA Asbestos Construction Standard. Work practices that would trigger these requirements include, but are not limited to, repair, maintenance, or renovation of structures containing asbestos, as well as removal or encapsulation of materials containing asbestos. For each project, the contractor must determine the appropriate safety measures based on the area to be disturbed, the type, volume, and condition of materials containing trace amounts of asbestos. Applicable work practice guidelines involving the disturbance of materials containing trace amounts of asbestos are summarized, but are not limited to:

- Employees must utilize appropriate engineering controls and personal protective equipment (PPE). This PPE includes disposable coveralls, gloves, eye protection, steel-

toed boots, a hard hat, and a National Institute for Occupational Safety and Health (NIOSH)-approved appropriate respirator.

- Employers must provide and require the use of appropriate PPE for any employee exposed to airborne concentrations of asbestos that exceed OSHA regulatory limits, or for which a required negative exposure assessment is not produced (29 CFR 1926.1101[i][1]).
- Employees must utilize respiratory protection until the initial exposure monitoring assessment documents safe working levels of airborne asbestos (29 CFR 1926.1101[f] and [h]). Additional periodic exposure monitoring may be required.
- An initial exposure monitoring assessment should be carried out when workers are disturbing ACM or materials containing trace amounts of asbestos to ensure that they are not exposed to airborne asbestos concentrations greater than the Permissible Exposure Limit (PEL) of 0.1 fibers per cubic centimeter (f/cc) of air as an 8-hour time-weighted average (TWA), and the Excursion Limit of 1.0 f/cc over a 30 minute sampling period.
- The work site must be maintained as a controlled regulated area and supervised by a competent person.
- Employees must implement stringent dust control procedures to prevent asbestos in any airborne dust.
- Employees must clean the work area thoroughly using wet methods and a high-efficiency particulate air (HEPA) vacuum. Dry sweeping or air blowing of asbestos debris and dust must be avoided.
- Waste and dust containing ACM or materials containing trace amounts of asbestos must be collected separately from other construction debris. Employees should conduct prompt clean up and disposal of asbestos wastes and debris in leak-tight containers.
- Asbestos-containing waste must be packaged, labeled, stored, and disposed of in accordance with applicable regulations.
- Visually inspect the work area to ensure that all asbestos-containing debris and dust has been properly removed.
- Conduct clearance in accordance with contract specifications.

## 9.2 Lead-Containing Paints

Employees involved in renovation or demolition activities that disturb LCP or LBP must conduct work in accordance with 29 CFR 1926.62 OSHA Lead Construction Standard. Work practices that would trigger these requirements include, but are not limited to, sanding, blasting, welding, cutting, or scraping. For each project, the contractor must determine the appropriate safety measures based on the area to be disturbed, the lead concentration, and the paint condition. Applicable work practice guidelines involving the disturbance of lead paints are summarized, but are not limited to:

- Employees must utilize appropriate engineering controls and personal PPE. The PPE includes disposable coveralls, gloves, eye protection, steel-toed boots, a hard hat, and a NIOSH-approved appropriate respirator.
- Employees must utilize respiratory protection until the initial air monitoring assessment documents safe working levels of airborne lead (29 CFR 1926.62[d][1] and [2][i][A]).
- An exposure assessment should be carried out when employees are disturbing LCP or LBP to ensure that they are not exposed to airborne lead concentrations greater than the PEL of 50 micrograms per cubic meter ( $\mu\text{g}/\text{m}^3$ ) averaged over an 8-hour period. Additional periodic exposure monitoring may be required if the Action Level,  $30 \mu\text{g}/\text{m}^3$ , averaged over an 8-hour period is exceeded.
- Employees must implement stringent dust control procedures to prevent lead in any airborne dust.
- Employees must clean the work area thoroughly using wet methods and a HEPA vacuum. Dry sweeping or air blowing of lead debris and dust must be avoided.
- Lead-containing debris must be segregated from other wastes, collected, and containerized. Wastes must be characterized per State of Hawaii requirements, including a determination of the waste as hazardous or non-hazardous. Lead-containing waste must be handled and disposed of in accordance with applicable requirements.
- Visually inspect and verify the work area to ensure all lead-containing debris and dust has been properly removed and the project site is free of lead hazard.
- Conduct clearance in accordance with contract specifications.

### 9.3 Arsenic-Containing Materials

No arsenic-containing materials were identified in the targeted areas during this survey. Therefore, no special arsenic control measures are provided.

### 9.4 PCB-Containing Bulk Materials

PCBs were detected from the concrete surface of the inside water tank, especially, from floor debris, sealant joint, and coating materials in the range of 2.4 mg/kg and 210 mg/kg. Based on the analytical findings, removal of PCB-containing loose and flaky materials is warranted. The TSCA (40 CFR Part 761), Subpart G – PCB Spill Cleanup Policy, regulates the cleanup and disposal of PCB contamination. This policy establishes criteria that EPA will use to determine the adequacy of the cleanup of spills resulting from the release of materials containing PCBs at concentrations of 50 ppm or greater. The EPA established three cleanup standards based on the site use as follows:

- a) High Occupancy (most stringent clean up level)
- b) Low Occupancy
- c) Industrial Area

These cleanup standards, however, exclude certain spill situations from its scope, such as spills directly into surface waters, **drinking water**, sewers, grazing lands, and vegetable gardens. The PCB concern at the Paua Valley Water Reservoir may fall into category (d) excluded spills, (iii) **Spills that result in the direct contamination of any private or public drinking water sources or distribution systems** under 40 CFR 761.120.

The general requirements under 40 CFR 761.125(a) do apply to the excluded spills. In addition, the excluded situations require practicable, immediate actions to contain the area of contamination. While these situations may not always require more stringent cleanup measures, the EPA is excluding these scenarios because they will always involve significant factors that may not be adequately addressed by cleanup standards based upon typical spill characteristics. Thus, the responsible party shall notify the EPA Regional 9 office and obtain guidance for appropriate cleanup measures in the shortest possible time after discovery, but in no case later than 24 hours after discovery [40 CFR 761.125 (a)(i)].

Since the cleanup measures and levels are not available from the EPA at the time of this reporting, it is recommended to set up the most stringent cleanup goal regulated from TSCA which is the

goal classified as “High Occupancy Areas.” Once EPA’s directions and guidance are available, the clean-up goal and measures shall be implemented.

High occupancy area is generally defined as any area where PCB remediation waste has been disposed of onsite (including but not limited to any building, any floor/wall of the building, any enclosed space within the building), and where annual occupancy for any individual not wearing dermal and respiratory protection is 840 hours or more for non-porous surfaces and 335 hours or more for bulk PCB remediation waste. Examples include residence, school, day care center, sleeping quarters, a single or multiple occupancy 40 hours-per-week work station, a school classroom, a cafeteria in an industrial facility, a control room, and a work station at an assembly line. There are two options to meet the cleanup goal for “High Occupancy Areas” as follows:

- Option 1: clean up the impacted material to be less than or equal to 1 ppm ( $\leq 1$  ppm) in porous surface without further condition
- Option 2: clean up the impacted material between 1 and 10 ppm ( $>1$  to  $\leq 10$  ppm) if site covered with appropriate cap (encapsulation) and institutional control implemented (deed restriction)

Regardless of which option may be selected, the PCB level in the water after the water tank remediation must meet the EPA National Primary Drinking Water Regulations.

Prior to any PCB remediation/cleanup, all PCB work plans must be reviewed and approved by EPA Region 9. The PCB-containing material or PCB waste including demolished debris shall be tested for PCB and disposed of in accordance with TSCA. If PCB concentration of the waste is below the 50 mg/kg, the material may be eligible for disposal at a local landfill as non-TSCA regulated waste. If the results exceed 50 mg/kg, the waste and debris would be classified as TSCA regulated waste which must be disposed of at a permitted hazardous waste landfill or an approved PCB disposal facility, which are currently not available in the State of Hawaii.

Trained workers are required to remove PCB-containing material or waste, and the work must be performed in accordance with OSHA and EPA requirements. Engineering controls and personal protective equipment should be utilized to prevent PCB release or exposure. Applicable work practice guidelines involving PCB-containing materials or waste are summarized, but are not limited to:



- The Contractor shall prepare a Health and Safety Plan (HASP) for PCB remediation/removal work. The HASP shall include accident and emergency response, proper worker protection regarding machinery to be employed during project activities, worker protection from PCB exposure, and required PPE.
- Employees must utilize appropriate PPE. The PPE may include disposable coveralls, gloves, eye protection, steel-toed safety boots, a hard hat, and a NIOSH-approved appropriate respirator.
- All work involving PCB should be performed by properly trained and equipped personnel.
- Establish PCB controlled areas for removal or spill cleanup to prevent unauthorized entry of personnel. Maintain a log of employees working in PCB controlled areas.
- All PCB waste should be stored and disposed of in compliance with TSCA regulations, and all records involving PCB should be properly maintained.

## **10.0 LIMITATIONS**

Industry standard effort was made to identify suspected hazardous building materials during the survey at the project area. However, this does not imply a guarantee that all suspected building materials and hazardous materials were identified by this assessment because certain building materials and/or surfaces may be hidden by walls, flooring, partitions, or other building components. If any previously unforeseen suspected materials become uncovered, additional survey may be required prior to the planned tank repair and rehabilitation project.

Material quantities provided in this report are based on visual approximations taken at the time of the survey only and should not be used for bidding purpose. It is the Contractor's responsibility to determine the material quantities and volume of waste prior to bidding.

## **APPENDIX A**

### **INSPECTOR CERTIFICATIONS**

**Akari Ihara**

**Danny Falanug**



# State of Hawai'i Asbestos Certification

## Training Course Exp. Dates

W	n/a	MP	n/a
CS	n/a	PD	n/a
INS	10/10/18	PM	09/21/18

**Ihara**  
Akari R.  
Myounghee Noh & Associates, L L C

**HIASB-1014**  
State Exp. Date **04/20/2018**

W= Worker  
CS= Cont /Sup  
INS= Inspector  
PD= Project Designer  
MP= Mgmt. Planner  
PM= Project Monitor

# State of Hawai'i Lead Based Paint Activities Certification

## Expiration Dates:

Inspector	n/a
Supervisor	n/a
Risk Assessor	09/17/2019
Project Designer	n/a
Worker	n/a

**Ihara**

**Akari**

Certification # PB-0056





# State of Hawai'i Asbestos Certification

## Training Course Exp. Dates

W	n/a	MP	n/a
CS	n/a	PD	n/a
INS	05/18/18	PM	05/19/18

W= Worker  
 CS= Cont./Sup.  
 INS= Inspector  
 PD= Project Designer  
 MP= Mgmt. Planner  
 PM= Project Monitor

**Falanug  
Danny**

Myounghee Noh & Associates, L.L.C.

**HIASB-3526**

**State Exp. Date 05/25/2018**

# State of Hawai'i Lead Based Paint Activities Certification

## Expiration Dates:

Inspector-	08/12/2019
Supervisor-	n/a
Risk Assessor-	n/a
Project Designer-	n/a
Worker-	n/a

**Falanug  
Danny**

**Certification # PB-0661**



## **APPENDIX B**

### **HOMOGENEOUS MATERIALS IDENTIFIED AND SAMPLE TYPES COLLECTED**

**Homogeneous Materials Identified and Sample Types Collected**

HM ID	Floor	Rooms	Locations	Material Color	Material	Substrate	Asb	Pb	PCB	Result
1	R	Exterior	Roofing system	Lt. blue	Paint	Concrete		X		LCP 710 - 1,200 mg/kg
2	R	Exterior	Roofing system	Lt. blue	Paint/skim coat	Concrete	X			ND
3	R	Exterior	Vent	Gray	Cement board	Concrete	X			ND
4	R	Exterior	Hatch	Dk. green	Paint	Metal		X		LBP 41,000 - 55,000 mg/kg
5	R	Exterior	Handrail, ladder	Lt. green	Paint	Metal		X		LCP 1,200 - 1,400 mg/kg
6	1	Interior	Floor	Beige	Coating	Concrete		X		LBP 40,000 - 41,000 mg/kg
7	1	Interior	Floor	Beige	Coating Cement material	Concrete	X			ND <0.25%* Chrysotile
8	1	Interior	Sealant joint	Beige	Coating Texture Tar	Concrete	X			ND
9	1	Interior	Walls	Black	Coating	Concrete	X			ND
10	1	Exterior	Walls	Orange	Paint	Concrete		X		<40 mg/kg
11	1	Exterior	Walls	Orange	Paint/skim coat	Concrete	X			ND
12	1	Exterior	Walls	Beige	Paint	Concrete		X		<40 mg/kg

**Homogeneous Materials Identified and Sample Types Collected**

HM ID	Floor	Rooms	Locations	Material Color	Material	Substrate	Asb	Pb	PCB	Result
13	1	Interior	Floor, debris	Beige	Coating	Concrete			X	Aroclor-1016, 1221, 1232, 1248: ND <b>Aroclor-1242: 2.3</b> <b>Aroclor-1254: 8.1</b> <b>Aroclor-1260: 18</b> Aroclor-1262: ND Aroclor-1268: ND <b>Total PCB: 28.4</b>
14	1	Interior	Sealant joint	Beige	Asphaltic base sealant	Concrete			X	Aroclor-1016, 1221, 1232, 1248: ND <b>Aroclor-1242: 2.4</b> <b>Aroclor-1254: 3.4</b> <b>Aroclor-1260: 4.7</b> Aroclor-1262: ND Aroclor-1268: ND <b>Total PCB: 10.5</b>
15	1	Interior	Walls	Black	Coating	Concrete			X	Aroclor-1016, 1221, 1232, 1242, 1248: ND <b>Aroclor-1254: 38</b> <b>Aroclor-1260: 76</b> Aroclor-1262: ND Aroclor-1268: ND <b>Total PCB: 114</b>
15C1	1	Interior	Walls	Black	Coating	Concrete			X	Aroclor-1016, 1221, 1232, 1242, 1248: ND <b>Aroclor-1254: 73</b> <b>Aroclor-1260: 210</b> Aroclor-1262: ND Aroclor-1268: ND <b>Total PCB: 283</b>

### Homogeneous Materials Identified and Sample Types Collected

HM ID	Floor	Rooms	Locations	Material Color	Material	Substrate	Asb	Pb	PCB	Result
15C2	1	Interior	Walls	Black	Coating	Concrete			X	Aroclor-1016, 1221, 1232, 1242, 1248: ND <b>Aroclor-1254: 51</b> <b>Aroclor-1260: 170</b> Aroclor-1262: ND Aroclor-1268: ND <b>Total PCB: 221</b>
15C3	1	Interior	Walls	Black	Coating	Concrete			X	Aroclor-1016, 1221, 1232, 1242, 1248: ND <b>Aroclor-1254: 39</b> <b>Aroclor-1260: 170</b> Aroclor-1262: ND Aroclor-1268: ND <b>Total PCB: 209</b>
9C1	1	Interior	Walls	Black	Coating	Concrete	X			ND

**Bold values indicate results above the reporting limit.**

\* Indicates that one or more asbestos fibers were detected by the point count method. While the less than 1% asbestos is not a regulated material, OSHA considers the trace amount as a health concern.

HM 9C1 is a confirmation sample for HM 9.

HM 15C1, 15C2, and 15C3 are confirmation samples for HM 15.

Abbreviations and Acronyms

Asb - Asbestos

HM ID - Homogeneous Material Identifier

LBP - Lead-Based Paint ≥5,000 mg/kg

LCP - Lead-Containing Paint <5,000 mg/kg

mg/kg - milligrams per kilogram, equivalent to parts per million

ND - Not Detected

Pb - Lead

PCB - Polychlorinated Biphenyls



## APPENDIX C

### SAMPLE AND HAZARDOUS MATERIAL LOCATION DRAWINGS

<b>List of Drawings</b>	
Asbestos and Lead Sample and Hazardous Material Locations Tank Interior	C-1 – C-3
Asbestos and Lead Sample and Hazardous Material Locations Tank Exterior	C-4 – C-5

HM ID	Locations	Material	Color	Substrate	Results
7	Floor	Coating Cement Material	Beige	Concrete	Trace <0.25%*

2388-A7A: ND  
 2388-A7B: ND  
 2388-A7C: ND  
 HM ID: 9C1 (Black coating on concrete wall)

2388-A5A: ND  
 2388-A5B: ND  
 2388-A5C: ND  
 HM ID: 9 (Black coating on concrete wall)

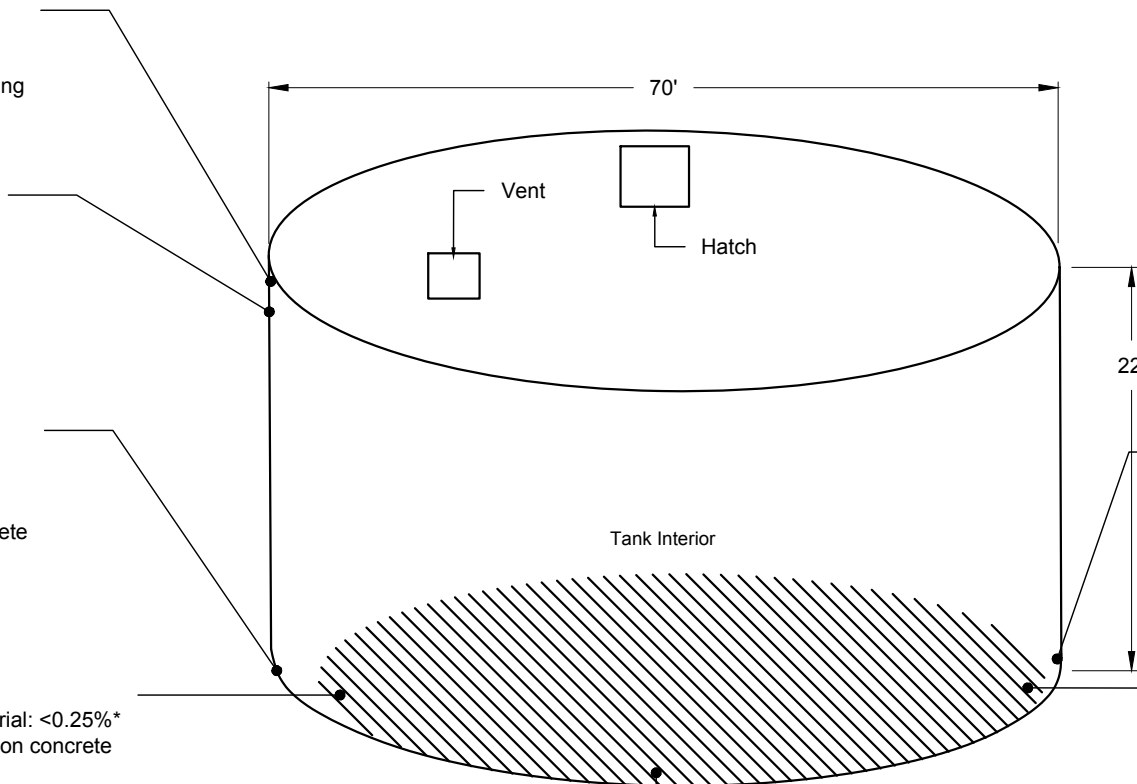
2388-A4A-Coating: ND  
 2388-A4A-Texture: ND  
 2388-A4A-Tar: ND  
 HM ID: 8 (Beige coating, texture, and tar on concrete sealant joint)

2388-A3A-Coating: ND  
 2388-A3A-Cement material: <0.25%\*  
 HM ID: 7 (Beige coating on concrete floor)

2388-A3B-Coating: ND  
 2388-A3A-Cement material: <0.25%\*  
 HM ID: 7 (Beige coating on concrete floor)

2388-A4B-Coating: ND  
 2388-A4B-Texture: ND  
 2388-A4B-Tar: ND  
 2388-A4C: ND  
 HM ID: 8 (Beige coating, texture, and tar on concrete sealant joint)

2388-A3C: ND  
 HM ID: 7 (Beige coating on concrete floor)



Myounghee Noh & Associates, L.L.C.

Sheet Number  
C - 1

Legend and Notes

**Visual Extent of Trace Asbestos**

All asbestos found to be chrysotile.

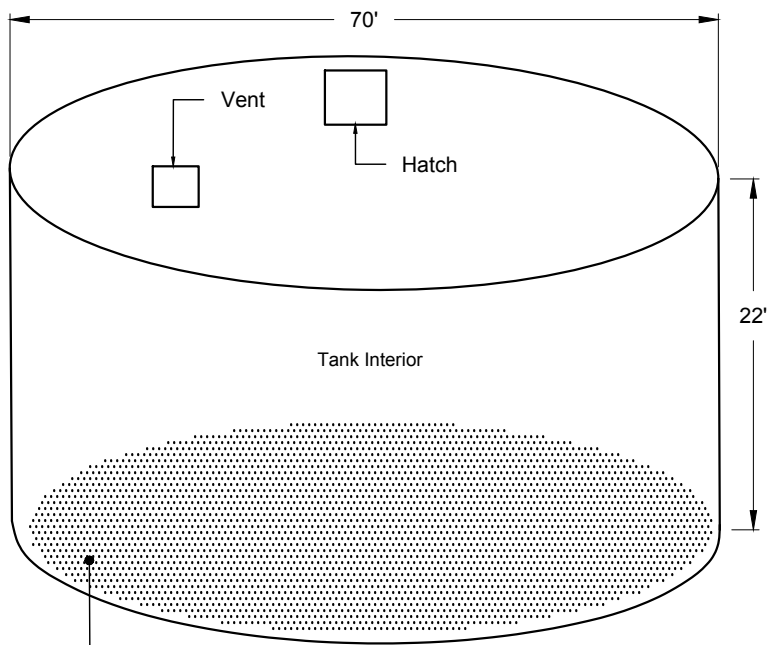
\* - Indicates that one or more asbestos fibers were detected by the point count method. While the less than 1% asbestos is not a regulated material, OSHA considers the trace amount as a health concern.

HM ID - Homogeneous Material Identifier

ND - None Detected

Asbestos Sample and Hazardous Material Locations  
 Kauai Department of Water Repair of Kekaha  
 0.6 MG Concrete Storage Tank Interior

HM ID	Locations	Color	Material	Substrate	Results (mg/kg)
6	Floor	Beige	Coating	Concrete	<b>LBP 40,000 - 41,000</b>




**2388-P4A: LBP 41,000 mg/kg**  
**2388-P4B: LBP 40,000 mg/kg**  
**HM ID: 6 (Beige coating on concrete floor)**



Myounghee Noh & Associates, L.L.C.

Legend and Notes

 **Visual Extent of Lead-Based Paint**

**Bold values indicate results above the detection limit.**

HM ID - Hazardous Material Identifier

LCP - Lead-Containing Paint < 5,000 mg/kg

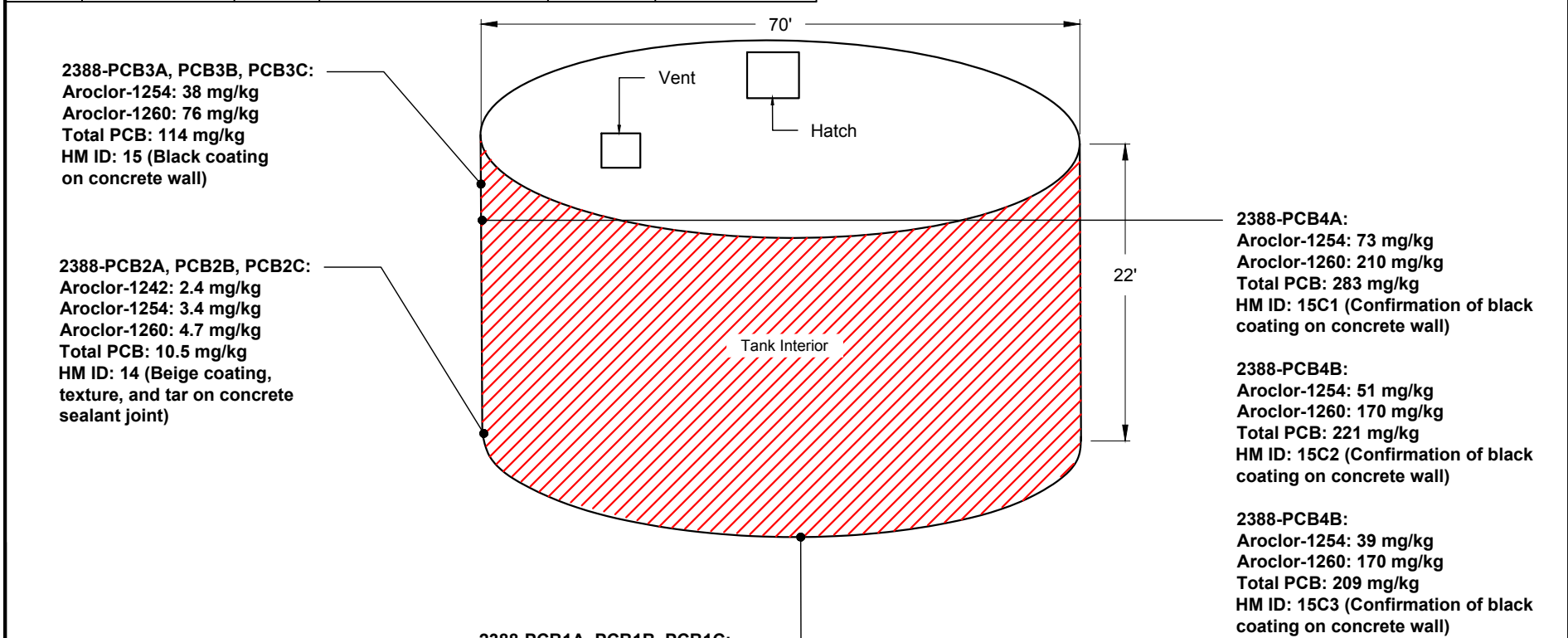
mg/kg - milligrams per kilogram (equivalent to ppm- parts per million)

Lead Sample and Hazardous  
Material Locations  
Kauai Department of Water Repair of Kekaha  
0.6 MG Concrete Storage Tank Interior

Sheet Number

C - 2

HM ID	Locations	Color	Material	Substrate	Results (mg/kg)
13	Floor, debris	Beige	Coating	Concrete	<b>Total PCB: 28.4</b>
14	Sealant joint	Beige	Coating, texture, and tar	Concrete	<b>Total PCB: 10.5</b>
15	Wall	Black	Coating	Concrete	<b>Total PCB: 114</b>
15C1	Wall	Black	Coating	Concrete	<b>Total PCB: 283</b>
15C2	Wall	Black	Coating	Concrete	<b>Total PCB: 221</b>
15C3	Wall	Black	Coating	Concrete	<b>Total PCB: 209</b>



Legend and Notes

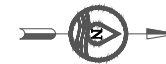
Visual Extent of PCB-Containing Material

**Bold values indicate results above the detection limit.**

ND - None Detected

PCB - Polychlorinated Biphenyls

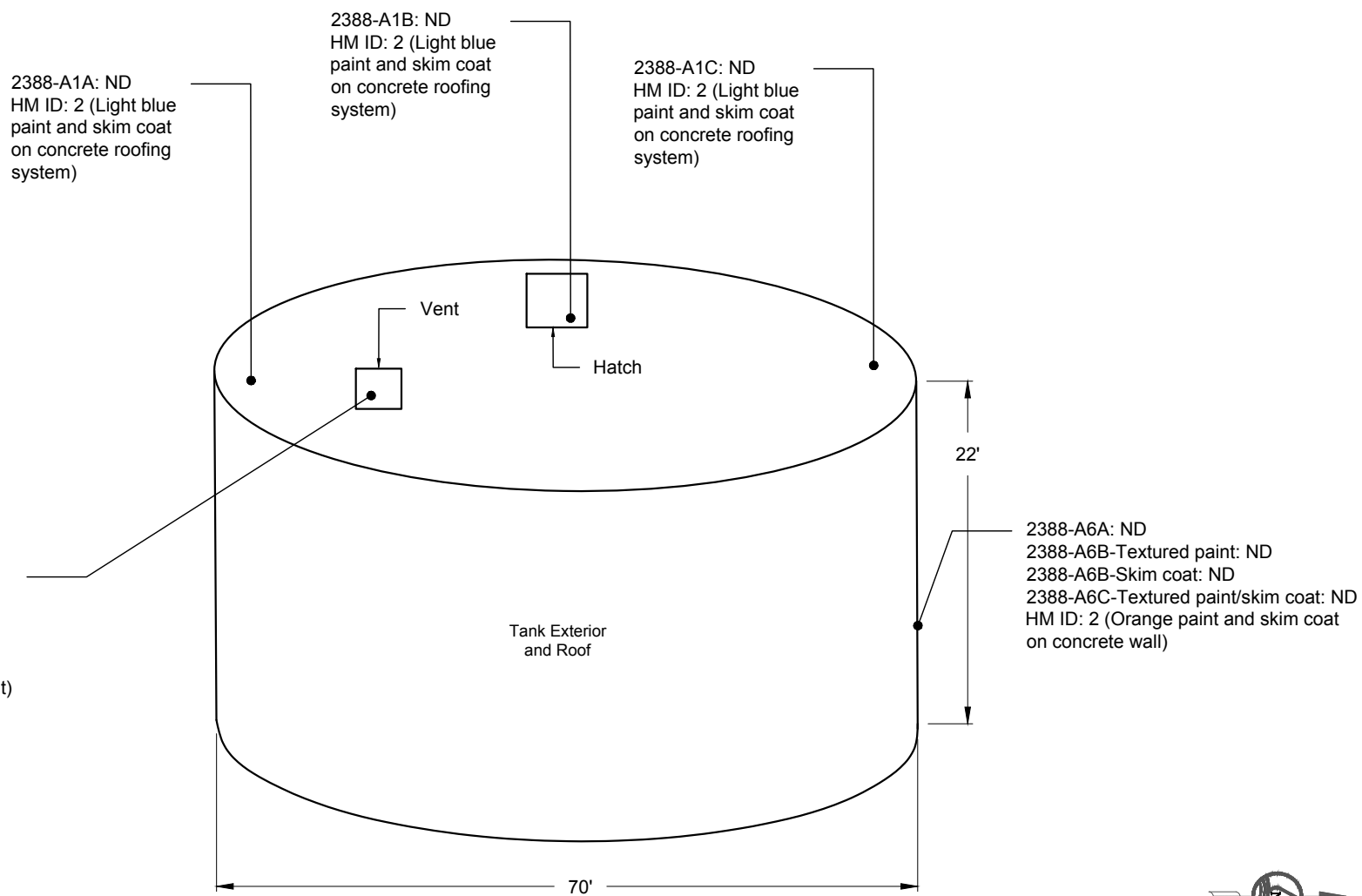
mg/kg - milligrams per kilogram (equivalent to ppm- parts per million)



Myounghee Noh & Associates, L.L.C.

PCB Sample and Hazardous  
 Material Locations  
 Kauai Department of Water Repair of Kekaha  
 0.6 MG Concrete Storage Tank Interior

Sheet Number  
 C - 3



Myounghee Noh & Associates, L.L.C.

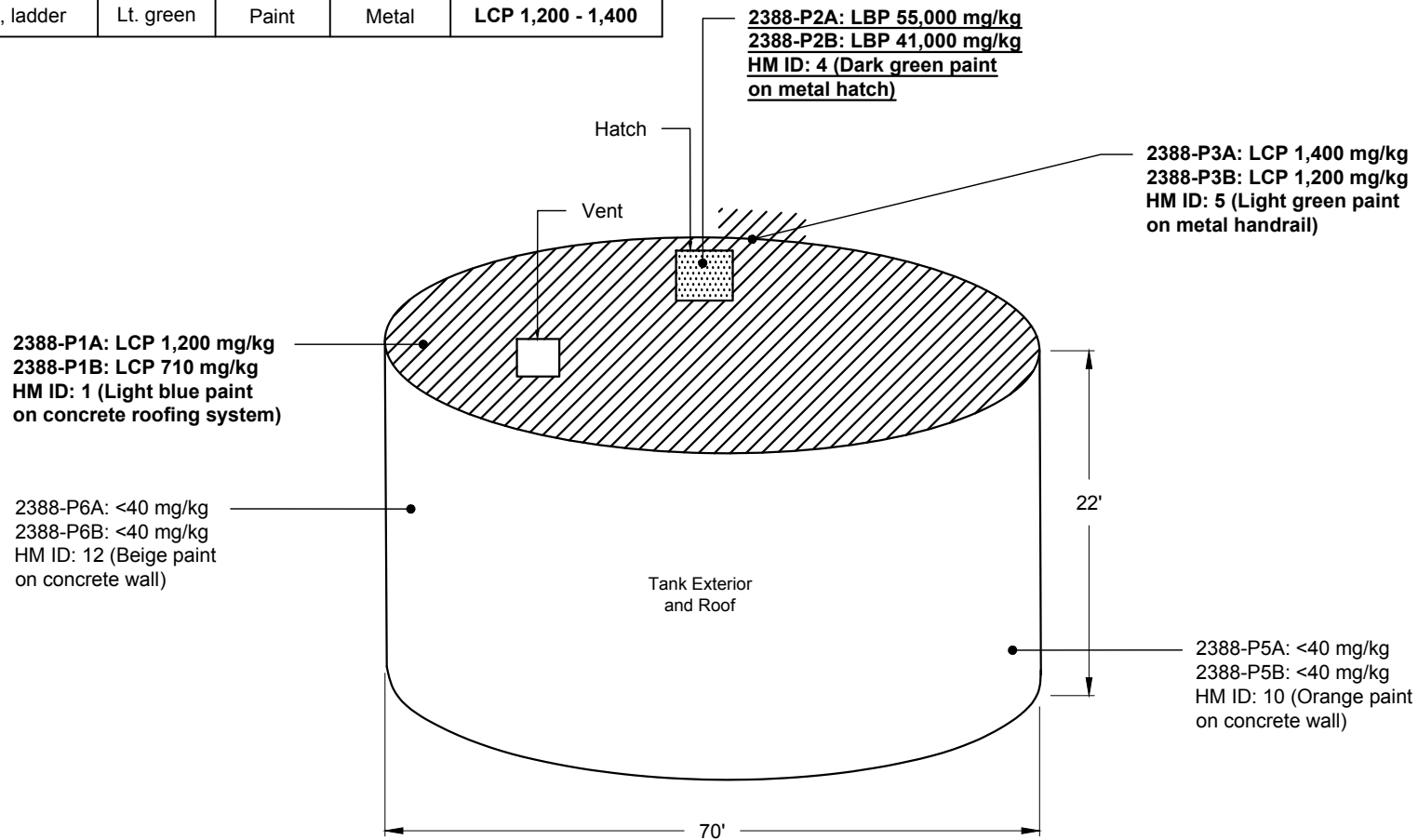
Legend and Notes

HM ID - Homogeneous Material Identifier  
ND - None Detected


Asbestos Sample Locations  
Kauai Department of Water Repair of Kekaha  
0.6 MG Concrete Storage Tank  
Exterior and Roof

Sheet Number  
C - 4

HM ID	Locations	Color	Material	Substrate	Results (mg/kg)
1	Roofing system	Lt. blue	Paint	Concrete	<b>LCP 710 - 1,200</b>
4	Hatch	Dk. green	Paint	Metal	<b>LBP 41,000 - 55,000</b>
5	Handrail, ladder	Lt. green	Paint	Metal	<b>LCP 1,200 - 1,400</b>



Legend and Notes

 Visual Extent of Lead-Based Paint

 Visual Extent of Lead-Containing Paint

**Bold values indicate results above the detection limit.**

HM ID - Hazardous Material Identifier

LBP - Lead-Based Paint  $\geq 5,000$  mg/kg

LCP - Lead-Containing Paint  $< 5,000$  mg/kg

mg/kg - milligrams per kilogram (equivalent to ppm- parts per million)



Myounghee Noh & Associates, L.L.C.

Lead Sample and Hazardous Material Locations  
Kauai Department of Water Repair of Kekaha 0.6  
MG Concrete Storage Tank Exterior and Roof

Sheet Number

C - 5

## **APPENDIX D**

## **PHOTOGRAPHS**



HM ID: 1  
0.5 MG Tank  
Roof

Exterior  
Light blue paint on concrete roofing system.

LCP  
2388-P1A: 1,200 mg/kg  
2388-P1B: 710 mg/kg



HM ID: 2  
0.5 MG Tank  
Roof

Exterior  
Light blue paint and skim coat on concrete roofing system.

Non-ACM  
2388-A1A: ND  
2388-A1B: ND  
2388-A1C: ND



HM ID: 3  
0.5 MG Tank  
Roof

Exterior  
Gray cement board on concrete vent.

Non-ACM  
2388-A2A: ND  
2388-A2B: ND  
2388-A2C: ND





HM ID: 4  
0.5 MG Tank  
Roof

Exterior  
Dark green paint on metal hatch.

**LBP**  
**2388-P2A: 55,000 mg/kg**  
**2388-P2B: 41,000 mg/kg**



HM ID: 5  
0.5 MG Tank  
Roof

Exterior  
Light green paint on metal handrail.

**LCP**  
**2388-P3A: 1,400 mg/kg**  
**2388-P3B: 2,100 mg/kg**



HM ID: 6  
0.5 MG Tank  
Floor 1

Interior  
Beige coating on concrete floor.

**LBP**  
**2388-P4A: 41,000 mg/kg**  
**2388-P4B: 40,000 mg/kg**



HM ID: 7  
0.5 MG Tank  
Floor 1

Interior  
Beige coating on concrete floor.

Trace ACM\*

2388-A3A-Coating: ND  
2388-A3A-Cementitious Material: <0.25% Chrysotile  
2388-A3B-Coating: ND  
2388-A3B-Cementitious Material: <0.25% Chrysotile  
2388-A3C: ND



HM ID: 8  
0.5 MG Tank  
Floor 1

Interior  
Beige asphaltic base sealant on concrete sealant joint.

Non-ACM

2388-A4A- Coating: ND  
2388-A4A-Texture: ND  
2388-A4A-Tar: ND  
2388-A4B-Coating: ND  
2388-A4B-Texture: ND  
2388-A4B-Tar: ND  
2388-A4C-Coating: ND  
2388-A4C-Texture: ND  
2388-A4C-Tar: ND



HM ID: 9  
0.5 MG Tank  
Floor 1

Interior  
Black coating on concrete wall.

Non-ACM

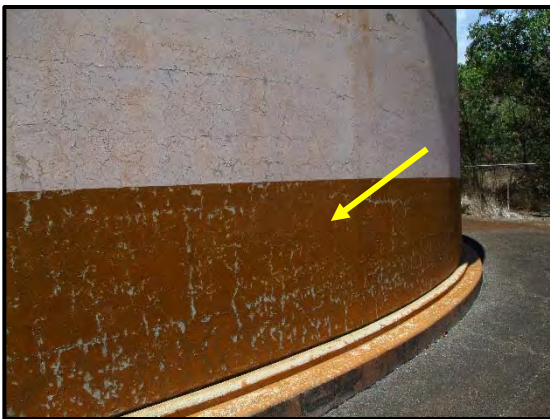
2388-A5A: ND  
2388-A5B: ND  
2388-A5C: ND



HM ID: 10  
0.5 MG Tank  
Floor 1

Exterior  
Orange paint on concrete wall.

Non-LCP  
2388-P5A: <40 mg/kg  
2388-P5B: <40 mg/kg



HM ID: 11  
0.5 MG Tank  
Floor 1

Exterior  
Orange paint and skim coat on concrete wall.

Non-ACM  
2388-A6A: ND  
2388-A6B-Texture Paint: ND  
2388-A6B-Skim Coat: ND  
2388-A6C-Texture Paint/Skim Coat: ND



HM ID: 12  
0.5 MG Tank  
Floor 1

Exterior  
Beige paint on concrete wall.

Non-LCP  
2388-P6A: <40 mg/kg  
2388-P6B: <40 mg/kg



HM ID: 13  
0.5 MG Tank  
Floor 1

Interior  
Beige coating on concrete floor.

**2388-PCB1A, PCB1B, PCB1C:**

Aroclor-1016: ND  
Aroclor-1221: ND  
Aroclor-1232: ND  
**Aroclor-1242: 2.3 mg/kg**  
Aroclor-1248: ND  
**Aroclor-1254: 8.1 mg/kg**  
**Aroclor-1260: 18 mg/kg**  
Aroclor-1262: ND  
Aroclor-1268: ND  
**Total PCB: 28.4 mg/kg**



HM ID: 14  
0.5 MG Tank  
Floor 1

Interior  
Beige asphaltic base sealant on concrete sealant joint.

**2388-PCB2A, PCB2B, PCB2C:**

Aroclor-1016: ND  
Aroclor-1221: ND  
Aroclor-1232: ND  
**Aroclor-1242: 2.4 mg/kg**  
Aroclor-1248: ND  
**Aroclor-1254: 3.4 mg/kg**  
**Aroclor-1260: 4.7 mg/kg**  
Aroclor-1262: ND  
Aroclor-1268: ND  
**Total PCB: 10.5 mg/kg**

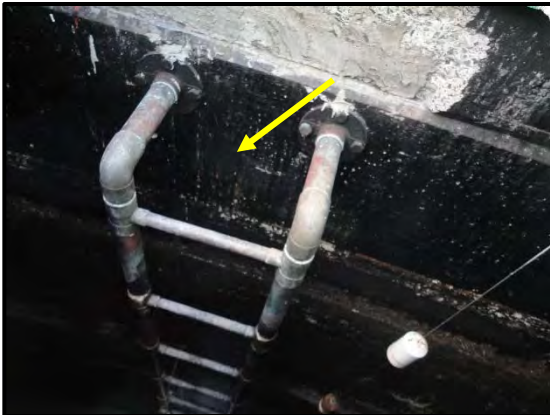


HM ID: 15  
0.5 MG Tank  
Floor 1

Interior  
Black coating on concrete wall.

**2388-PCB3A, PCB3B, PCB3C:**

Aroclor-1016: ND  
Aroclor-1221: ND  
Aroclor-1232: ND  
Aroclor-1242: ND  
Aroclor-1248: ND  
**Aroclor-1254: 38 mg/kg**  
**Aroclor-1260: 76 mg/kg**  
Aroclor-1262: ND  
Aroclor-1268: ND  
**Total PCB: 114 mg/kg**



HM ID: 15C1 (Confirmation Sample)  
0.5 MG Tank  
Floor 1

Interior  
Black coating on concrete wall.

**2388-PCB4A, PCB4B, PCB4C:**

Aroclor-1016: ND  
Aroclor-1221: ND  
Aroclor-1232: ND  
Aroclor-1242: ND  
Aroclor-1248: ND  
**Aroclor-1254: 73 mg/kg**  
**Aroclor-1260: 210 mg/kg**  
Aroclor-1262: ND  
Aroclor-1268: ND  
**Total PCB: 283 mg/kg**

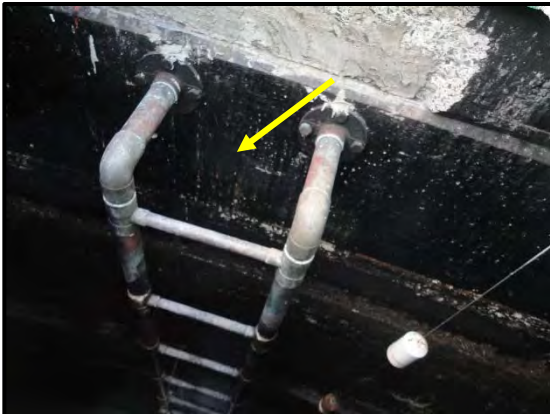


HM ID: 15C2 (Confirmation Sample)  
0.5 MG Tank  
Floor 1

Interior  
Black coating on concrete wall.

**2388-PCB4A, PCB4B, PCB4C:**

Aroclor-1016: ND  
Aroclor-1221: ND  
Aroclor-1232: ND  
Aroclor-1242: ND  
Aroclor-1248: ND  
**Aroclor-1254: 51 mg/kg**  
**Aroclor-1260: 170 mg/kg**  
Aroclor-1262: ND  
Aroclor-1268: ND  
**Total PCB: 221 mg/kg**



HM ID: 15C3 (Confirmation Sample)  
0.5 MG Tank  
Floor 1

Interior  
Black coating on concrete wall.

**2388-PCB4A, PCB4B, PCB4C:**

Aroclor-1016: ND  
Aroclor-1221: ND  
Aroclor-1232: ND  
Aroclor-1242: ND  
Aroclor-1248: ND  
**Aroclor-1254: 39 mg/kg**  
**Aroclor-1260: 170 mg/kg**  
Aroclor-1262: ND  
Aroclor-1268: ND  
**Total PCB: 209 mg/kg**



HM ID: 9C1 (Confirmation)  
0.5 MG Tank  
Floor 1

Interior  
Black coating on concrete wall.

Non-ACM  
2388-A7A: ND  
2388-A7B: ND  
2388-A7C: ND

\*Indicates that one or more asbestos fibers were detected by the point count method. While the <1% asbestos is not a regulated material, OSHA considers the trace amount as a health hazard.

## **APPENDIX E**

### **LABORATORY ANALYTICAL REPORTS**





# LA Testing

520 Mission Street South Pasadena, CA 91030  
Tel/Fax: (323) 254-9960 / (323) 254-9982  
<http://www.LATesting.com / pasadenalab@latesting.com>

LA Testing Order: 321720066  
Customer ID: 32MYOU50  
Customer PO:  
Project ID:

Attention: Akari Ihara  
Myounghee Noh & Associates, LLC  
99-1046 Iwaena Street  
Suite 210A  
Aiea, HI 96701

Phone: (808) 358-1421

Fax:

Received Date: 08/21/2017 9:20 AM

Analysis Date: 08/25/2017

Collected Date:

Project: 2388.3

## Test Report: Asbestos Analysis of Bulk Materials via EPA 600/R-93/116 Method using Polarized Light Microscopy

Sample	Description	Appearance	Non-Asbestos		Asbestos
			% Fibrous	% Non-Fibrous	% Type
2388.A1A <small>321720066-0001</small>	Ext Roof System - P/SC	Gray Non-Fibrous Homogeneous		100% Non-fibrous (Other)	None Detected
2388.A1B <small>321720066-0002</small>	Ext Roof System - P/SC	Green Non-Fibrous Homogeneous		100% Non-fibrous (Other)	None Detected
2388.A1C <small>321720066-0003</small>	Ext Roof System - P/SC	Green/Beige Non-Fibrous Homogeneous		100% Non-fibrous (Other)	None Detected
2388.A2A <small>321720066-0004</small>	Ext Vent - Gray cementitas	Gray Non-Fibrous Homogeneous		100% Non-fibrous (Other)	None Detected
2388.A2B <small>321720066-0005</small>	Ext Vent - Gray cementitas	Gray Non-Fibrous Homogeneous		100% Non-fibrous (Other)	None Detected
2388.A2C <small>321720066-0006</small>	Ext Vent - Gray cementitas	Gray Non-Fibrous Homogeneous		100% Non-fibrous (Other)	None Detected
2388.A3A-Coating <small>321720066-0007</small>	Lut Floor - beige coating	Beige/Orange Non-Fibrous Homogeneous		100% Non-fibrous (Other)	None Detected
2388.A3A-Cementitious Material <small>321720066-0007A</small>	Lut Floor - beige coating	Brown/Gray Non-Fibrous Homogeneous		100% Non-fibrous (Other)	<1% Chrysotile
2388.A3B-Coating <small>321720066-0008</small>	Lut Floor - beige coating	Beige/Orange Non-Fibrous Homogeneous		100% Non-fibrous (Other)	None Detected
2388.A3B-Cementitious Material <small>321720066-0008A</small>	Lut Floor - beige coating	Gray Non-Fibrous Homogeneous		100% Non-fibrous (Other)	<1% Chrysotile
2388.A3C <small>321720066-0009</small>	Lut Floor - beige coating	Beige/Orange Non-Fibrous Homogeneous		100% Non-fibrous (Other)	None Detected
2388.A4A-Coating <small>321720066-0010</small>	Lut Sealant Joint - beige asphalt base sealant	Orange Non-Fibrous Homogeneous		100% Non-fibrous (Other)	None Detected
2388.A4A-Texture <small>321720066-0010A</small>	Lut Sealant Joint - beige asphalt base sealant	Gray Non-Fibrous Homogeneous		100% Non-fibrous (Other)	None Detected
2388.A4A-Tar <small>321720066-0010B</small>	Lut Sealant Joint - beige asphalt base sealant	Black Non-Fibrous Homogeneous		100% Non-fibrous (Other)	None Detected
2388.A4B-Coating <small>321720066-0011</small>	Lut Sealant Joint - beige asphalt base sealant	Orange Non-Fibrous Homogeneous		100% Non-fibrous (Other)	None Detected

Initial report from: 08/25/2017 14:24:05



# LA Testing

520 Mission Street South Pasadena, CA 91030

Tel/Fax: (323) 254-9960 / (323) 254-9982

<http://www.LATesting.com> / [pasadenalab@lateesting.com](mailto:pasadenalab@lateesting.com)

LA Testing Order: 321720066

Customer ID: 32MYOU50

Customer PO:

Project ID:

## Test Report: Asbestos Analysis of Bulk Materials via EPA 600/R-93/116 Method using Polarized Light Microscopy

Sample	Description	Appearance	Non-Asbestos		Asbestos
			% Fibrous	% Non-Fibrous	% Type
2388.A4B-Texture <small>321720066-0011A</small>	Lut Sealant Joint - beige asphalt base sealant	Gray Non-Fibrous Homogeneous		100% Non-fibrous (Other)	None Detected
2388.A4B-Tar <small>321720066-0011B</small>	Lut Sealant Joint - beige asphalt base sealant	Black Non-Fibrous Homogeneous		100% Non-fibrous (Other)	None Detected
2388.A4C <small>321720066-0012</small>	Lut Sealant Joint - beige asphalt base sealant	Black Non-Fibrous Homogeneous		100% Non-fibrous (Other)	None Detected
2388.A5A <small>321720066-0013</small>	Lut Walls - black coating	Black Non-Fibrous Homogeneous		100% Non-fibrous (Other)	None Detected
2388.A5B <small>321720066-0014</small>	Lut Walls - black coating	Black Non-Fibrous Homogeneous		100% Non-fibrous (Other)	None Detected
2388.A5C <small>321720066-0015</small>	Lut Walls - black coating	Black Non-Fibrous Homogeneous		100% Non-fibrous (Other)	None Detected
2388.A6A <small>321720066-0016</small>	Ext Walls - orange P/SC	Orange Non-Fibrous Homogeneous		100% Non-fibrous (Other)	None Detected
2388.A6B-Texture Paint <small>321720066-0017</small>	Ext Walls - orange P/SC	Orange Non-Fibrous Homogeneous		100% Non-fibrous (Other)	None Detected
2388.A6B-Skim Coat <small>321720066-0017A</small>	Ext Walls - orange P/SC	Gray Non-Fibrous Homogeneous		100% Non-fibrous (Other)	None Detected
2388.A6C-Texture Paint/Skim Coat <small>321720066-0018</small>	Ext Walls - orange P/SC	Gray/Orange Non-Fibrous Heterogeneous		100% Non-fibrous (Other)	None Detected

Unable to separate.

Analyst(s)

Julie Vong (6)

Kieu-anh Pham Duong (19)

Jerry Drapala Ph.D, Laboratory Manager  
or Other Approved Signatory

EMSL maintains liability limited to cost of analysis. This report relates only to the samples reported and may not be reproduced, except in full, without written approval by EMSL. EMSL bears no responsibility for sample collection activities or analytical method limitations. Interpretation and use of test results are the responsibility of the client. This report must not be used by the client to claim product certification, approval, or endorsement by NVLAP, NIST or any agency of the federal government. Non-friable organically bound materials present a problem matrix and therefore EMSL recommends gravimetric reduction prior to analysis. Samples received in good condition unless otherwise noted. Estimated accuracy, precision and uncertainty data available upon request. Unless requested by the client, building materials manufactured with multiple layers (i.e. linoleum, wallboard, etc.) are reported as a single sample. Reporting limit is 1%

Samples analyzed by LA Testing South Pasadena, CA NVLAP Lab Code 200232-0, CA ELAP 2283

Initial report from: 08/25/2017 14:24:05



**Asbestos Chain of Custody**  
**EMSL Order Number (Lab Use Only):**

#321720066

LATESTING  
 520 MISSION STREET  
 SOUTH PASADENA, CA 91030  
 PHONE: (800)-303-0047  
 FAX: (323)-254-9962

Company : Myounghee Noh & Associates L.L.C		EMSL-Bill to: <input type="checkbox"/> Same <input type="checkbox"/> Different If Bill to is Different note instructions in Comments**	
Street:99-1046 Iwaena St.		Third Party Billing requires written authorization from third party	
City:Aiea	State/Province:Hawaii	Zip/Postal Code:	Country:
Report To (Name): AKari		Telephone #:	
Email Address:		Fax #:	Purchase Order:
Project Name/Number: 2388-3		Please Provide Results: <input type="checkbox"/> Fax <input type="checkbox"/> Email <input type="checkbox"/> Mail	
U.S. State Samples Taken: 4		Connecticut Samples: <input type="checkbox"/> Commercial <input type="checkbox"/> Residential	

**Turnaround Time (TAT) Options\* - Please Check**

3 Hour  6 Hour  24 Hour  48 Hour  72 Hour  96 Hour  1 Week  2 Week

\*For TEM Air 3 hr through 6 hr, please call ahead to schedule. \*There is a premium charge for 3 Hour TEM AHERA or EPA Level II TAT. You will be asked to sign an authorization form for this service. Analysis completed in accordance with EMSL's Terms and Conditions located in the Analytical Price Guide.

<b>PCM - Air</b> <input type="checkbox"/> Check if samples are from NY <input type="checkbox"/> NIOSH 7400 <input type="checkbox"/> w/ OSHA 8hr. TWA	<b>TEM - Air</b> <input type="checkbox"/> 4-4.5hr TAT (AHERA only) <input type="checkbox"/> AHERA 40 CFR, Part 763 <input type="checkbox"/> NIOSH 7402 <input type="checkbox"/> EPA Level II <input type="checkbox"/> ISO 10312	<b>TEM- Dust</b> <input type="checkbox"/> Microvac - ASTM D 5755 <input type="checkbox"/> Wipe - ASTM D6480 <input type="checkbox"/> Carpet Sonication (EPA 600/J-93/167)
<b>PLM - Bulk (reporting limit)</b> <input checked="" type="checkbox"/> PLM EPA 600/R-93/116 (<1%) <input type="checkbox"/> PLM EPA NOB (<1%) Point Count <input type="checkbox"/> 400 (<0.25%) <input type="checkbox"/> 1000 (<0.1%) Point Count w/Gravimetric <input type="checkbox"/> 400 (<0.25%) <input type="checkbox"/> 1000 (<0.1%) <input type="checkbox"/> NYS 198.1 (friable in NY) <input type="checkbox"/> NYS 198.6 NOB (non-friable-NY) <input type="checkbox"/> NIOSH 9002 (<1%)	<b>TEM - Bulk</b> <input type="checkbox"/> TEM EPA NOB <input type="checkbox"/> NYS NOB 198.4 (non-friable-NY) <input type="checkbox"/> Chatfield SOP <input type="checkbox"/> TEM Mass Analysis-EPA 600 sec. 2.5	<b>Soil/Rock/Vermiculite</b> <input type="checkbox"/> PLM CARB 435 - A (0.25% sensitivity) <input type="checkbox"/> PLM CARB 435 - B (0.1% sensitivity) <input type="checkbox"/> TEM CARB 435 - B (0.1% sensitivity) <input type="checkbox"/> TEM CARB 435 - C (0.01% sensitivity) <input type="checkbox"/> TEM Qual. via Filtration Technique <input type="checkbox"/> TEM Qual. via Drop-Mount Technique
<b>TEM - Water: EPA 100.2</b> Fibers >10µm <input type="checkbox"/> Waste <input type="checkbox"/> Drinking All Fiber Sizes <input type="checkbox"/> Waste <input type="checkbox"/> Drinking		<b>Other:</b> <input type="checkbox"/>

Check For Positive Stop - Clearly Identify Homogenous Group **Filter Pore Size (Air Samples):**  0.8µm  0.45µm

Samplers Name: AKari Samplers Signature: *AKari*

Sample #	Sample Description	Volume/Area (Air) HA # (Bulk)	Date/Time Sampled
2388-A1A ↓ ↓ B	bulk		
↓ ↓ C			
2388-A6A ↓ ↓ B			
↓ ↓ C			

Client Sample # (s): 2388-A1A ~ 2388-A6C Total # of Samples: 18

Relinquished (Client): *AKari* Date: 8.18.17 Time:

Received (Lab): DFlones (EMSL FedEx) Date: 8/21/17 Time: 9:20 am

Comments/Special Instructions:

**Hazardous Homogeneous Materials and Sampling Survey Field Form: Asbestos**

Project Number: 2388 3 Location: DOW Kekaha 0.5MG Storage Tank Inspector Initials: AI Survey Dates and Times: 8.17.17

HM ID	Building	Flr.	Rooms	Locations	Material Color	Material	Substrate	Condition	Friable ACM	Area Sq. ft or L. ft	Hatch Color
									Type		
2	0.5 MG Tank	R	ext	Roof systems	H. blue	P/S	cc	G F P	Y <input checked="" type="checkbox"/> TSI <input checked="" type="checkbox"/>	2,000	-

Sample ID	Room Sampled	Sample Location	PIC ID	Notes
2388-A 1A	ext	Roof systems	1491	
2388-A 1B	↓	↓		
2388-A 1C	↓	↓		

HM ID	Building	Flr.	Rooms	Locations	Material Color	Material	Substrate	Condition	Friable ACM	Area Sq. ft or L. ft	Hatch Color
									Type		
3	0.5 MG Tank	R	ext	vent	Gray	concrete	cc	G F P	Y <input checked="" type="checkbox"/> TSI <input checked="" type="checkbox"/>	5	-

Sample ID	Room Sampled	Sample Location	PIC ID	Notes
2388-A 2A	ext	vent	1493	
2388-A 2B	↓	↓		
2388-A 2C	↓	↓		

HM ID	Building	Flr.	Rooms	Locations	Material Color	Material	Substrate	Condition	Friable ACM	Area Sq. ft or L. ft	Hatch Color
									Type		
7	0.5 MG Tank		int	floor	beige	concrete	cc	G F P	Y <input checked="" type="checkbox"/> TSI <input checked="" type="checkbox"/>	5,000	-

Sample ID	Room Sampled	Sample Location	PIC ID	Notes
2388-A 3A	int	floor	1504	
2388-A 3B	↓	↓		
2388-A 3C	↓	↓		

#321720066

Order ID: 321720066

**Hazardous Homogeneous Materials and Sampling Survey Field Form: Asbestos**

Project Number: 2388 3 Location: DOW Kekaha 0.5MG Storage Tank Inspector Initials: AI Survey Dates and Times: 6.17.17

HM ID	Building	Flr.	Rooms	Locations	Material Color	Material	Substrate	Condition	Friable ACM	Area Sq. ft or L. ft	Hatch Color
									Type		
8	0.5MG tank	1	int	Sealant Joint	Grey	Asphalt concrete sealant	CC	GFP	Y (N) TSI S (M)	5,000 4,000	-

Sample ID	Room Sampled	Sample Location	PIC ID	Notes
2388-A 4 A	int	Sealant Joint	1501	
2388-A 4 B	↓	↓		
2388-A 4 C	↓	↓		

HM ID	Building	Flr.	Rooms	Locations	Material Color	Material	Substrate	Condition	Friable ACM	Area Sq. ft or L. ft	Hatch Color
									Type		
9	0.5MG Tank	1	int	walls	Grey	<del>P/S</del> black coating	CC	GFP	Y (N) TSI S (M)	10,000	-

Sample ID	Room Sampled	Sample Location	PIC ID	Notes
2388-A 5 A	int	walls	1501	
2388-A 5 B	↓	↓		
2388-A 5 C	↓	↓		

HM ID	Building	Flr.	Rooms	Locations	Material Color	Material	Substrate	Condition	Friable ACM	Area Sq. ft or L. ft	Hatch Color
									Type		
10	0.5MG Tank	1	ext	walls	Grey	P/SC	CC	GFP	Y (N) TSI S (M)	10,000	-

Sample ID	Room Sampled	Sample Location	PIC ID	Notes
2388-A 6 A	ext	walls	1509	
2388-A 6 B	↓	↓		
2388-A 6 C	↓	↓		

Page 3 of 4



# EMSL Analytical, Inc.

200 Route 130 North Cinnaminson, NJ 08077

Tel/Fax: (800) 220-3675 / (856) 786-5974

<http://www.EMSL.com> / [cinnasblab@EMSL.com](mailto:cinnasblab@EMSL.com)

EMSL Order: 041731009

Customer ID: 32MYOU50

Customer PO:

Project ID:

**Attention:** Akari Ihara  
Myounghee Noh & Associates, LLC  
99-1046 Iwaena Street  
Suite 210A  
Aiea, HI 96701

**Phone:** (808) 358-1421

**Fax:**

**Received Date:** 10/25/2017 4:30 PM

**Analysis Date:** 10/27/2017

**Collected Date:**

**Project:** 23883

## Test Report: Asbestos Analysis of Bulk Materials via EPA 600/R-93/116 Method using Polarized Light Microscopy

Sample	Description	Appearance	Non-Asbestos		Asbestos
			% Fibrous	% Non-Fibrous	% Type
2388-A7A <small>041731009-0001</small>	P2388-PCB4A	Brown/Black Non-Fibrous Homogeneous		100% Non-fibrous (Other)	None Detected
2388-A7B <small>041731009-0002</small>	P2388-PCB4B	Black Non-Fibrous Homogeneous		100% Non-fibrous (Other)	None Detected
2388-A7C <small>041731009-0003</small>	P2388-PCB4C	Black Non-Fibrous Homogeneous		100% Non-fibrous (Other)	None Detected

Analyst(s)

Steven Quinn (2)

Seri Smith (1)

Benjamin Ellis, Laboratory Manager  
or Other Approved Signatory

EMSL maintains liability limited to cost of analysis. This report relates only to the samples reported and may not be reproduced, except in full, without written approval by EMSL. EMSL bears no responsibility for sample collection activities or analytical method limitations. Interpretation and use of test results are the responsibility of the client. This report must not be used by the client to claim product certification, approval, or endorsement by NVLAP, NIST or any agency of the federal government. Non-friable organically bound materials present a problem matrix and therefore EMSL recommends gravimetric reduction prior to analysis. Samples received in good condition unless otherwise noted. Estimated accuracy, precision and uncertainty data available upon request. Unless requested by the client, building materials manufactured with multiple layers (i.e. linoleum, wallboard, etc.) are reported as a single sample. Reporting limit is 1%

Samples analyzed by EMSL Analytical, Inc. Cinnaminson, NJ NVLAP Lab Code 101048-0, AIHA-LAP, LLC-IHLAP Lab 100194, NYS ELAP 10872, NJ DEP 03036, PA ID# 68-00367

Initial report from: 10/27/2017 18:10:40



**Asbestos Chain of Custody**

EMSL Order Number (Lab Use Only):

041731009

LATESTING  
5200 EMISSION STREET  
SOUTH PASADENA, CA 91030  
CINNAMON POWER (800) 803-0047  
FAX: (323) 254-9962

2017 OCT 25 P 4:32

Company: Myounghee Noh & Associates L.L.C  
 Street: 99-1046 Iwaena St.  
 City: Aiea State/Province: Hawaii Zip/Postal Code: Country:  
 Report To (Name): AKARI Telephone #:  
 Email Address: Fax #: Purchase Order:  
 Project Name/Number: 2388.3 Please Provide Results:  Fax  Email  Mail  
 U.S. State Samples Taken: HI Connecticut Samples:  Commercial  Residential

Turnaround Time (TAT) Options\* - Please Check  
 3 Hour  6 Hour  24 Hour  48 Hour  72 Hour  96 Hour  1 Week  2 Week

\*For TEM Air 3 hr through 6 hr, please call ahead to schedule. There is a premium charge for 3 Hour TEM AHERA or EPA Level II TAT. You will be asked to sign an authorization form for this service. Analysis completed in accordance with EMSL's Terms and Conditions located in the Analytical Price Guide.

<b>PCM - Air</b> <input type="checkbox"/> Check if samples are from NY <input type="checkbox"/> NIOSH 7400 <input type="checkbox"/> w/ OSHA 8hr. TWA <b>PLM - Bulk (reporting limit)</b> <input checked="" type="checkbox"/> PLM EPA 600/R-93/116 (<1%) <input type="checkbox"/> PLM EPA NOB (<1%) Point Count <input type="checkbox"/> 400 (<0.25%) <input type="checkbox"/> 1000 (<0.1%) Point Count w/Gravimetric <input type="checkbox"/> 400 (<0.25%) <input type="checkbox"/> 1000 (<0.1%) <input type="checkbox"/> NYS 198.1 (friable in NY) <input type="checkbox"/> NYS 198.6 NOB (non-friable-NY) <input type="checkbox"/> NIOSH 9002 (<1%)	<b>TEM - Air</b> <input type="checkbox"/> 4-4.5hr TAT (AHERA only) <input type="checkbox"/> AHERA 40 CFR, Part 763 <input type="checkbox"/> NIOSH 7402 <input type="checkbox"/> EPA Level II <input type="checkbox"/> ISO 10312 <b>TEM - Bulk</b> <input type="checkbox"/> TEM EPA NOB <input type="checkbox"/> NYS NOB 198.4 (non-friable-NY) <input type="checkbox"/> Chatfield SOP <input type="checkbox"/> TEM Mass Analysis-EPA 600 sec. 2.5 <b>TEM - Water: EPA 100.2</b> Fibers >10µm <input type="checkbox"/> Waste <input type="checkbox"/> Drinking All Fiber Sizes <input type="checkbox"/> Waste <input type="checkbox"/> Drinking	<b>TEM- Dust</b> <input type="checkbox"/> Microvac - ASTM D 5755 <input type="checkbox"/> Wipe - ASTM D6480 <input type="checkbox"/> Carpet Sonication (EPA 600/J-93/167) <b>Soil/Rock/Vermiculite</b> <input type="checkbox"/> PLM CARB 435 - A (0.25% sensitivity) <input type="checkbox"/> PLM CARB 435 - B (0.1% sensitivity) <input type="checkbox"/> TEM CARB 435 - B (0.1% sensitivity) <input type="checkbox"/> TEM CARB 435 - C (0.01% sensitivity) <input type="checkbox"/> TEM Qual. via Filtration Technique <input type="checkbox"/> TEM Qual. via Drop-Mount Technique <b>Other:</b> <input type="checkbox"/>
---	--	---

Check For Positive Stop - Clearly Identify Homogenous Group Filter Pore Size (Air Samples):  0.8µm  0.45µm

Samplers Name: Samplers Signature: *AKARI*

Sample #	Sample Description	Volume/Area (Air) HA # (Bulk)	Date/Time Sampled
2388. A7A	Use PCB samples (P2388. PCB4A		
↓ ↓ B	↓ ↓ ↓ B		
↓ ↓ C	↓ ↓ ↓ C		

Client Sample # (s): 2388. A7A, B, C - Total # of Samples: 3  
 Relinquished (Client): *AKARI* Date: 10.23.17 Time:  
 Received (Lab): *W* Date: 10-25-17 Time: 4:30pm  
 Comments/Special Instructions:

#321720066

2

ORIGIN ID: NAVE (000) 484-9214  
MOULDER, NICHOL ASSOCIATES, LLC  
86-1040 IMBENA STREET SUITE 210A  
ANA, HI 96701  
UNITED STATES US

SHIP DATE: 18AUG17  
C/D: 1022085800MS02000

TO SAMPLE RECEIVING  
LA TESTING  
520 MISSION STREET

SOUTH PASADENA CA 91030  
REF: AR-ME/VA 20A01050  
PZY



RETURNS MON-FRI  
PRIORITY OVERNIGHT

TRK# 7953 2369 9011

91030

CA-US



**IMPORTANT! Do not duplicate this label. Each package must contain a unique tracking number in order to maintain tracking and billing integrity.**

Use of this FedEx shipping label is subject to the following restrictions and conditions:

**Disclaimer**

1. The shipment must be via FedEx packaging (FedEx envelope pack or FedEx box), this label is not valid for use on non-standard packages nor coolers.
2. Valid for shipment of the following samples only: Lead analysis of paint chips, air samples, or wipe samples; Absorbent testing of bulk material samples, wipe/dust samples, or air sample cassettes; Microbiology air samples or bulk samples; tape lift samples, and/or snab samples. This label and shipping is not valid for shipment of any sample that requires a cooler or any other sample type not specifically described herein.
3. The package shipment must exceed a minimum of \$100 in analytical fees. If this minimum is not met, a minimum shipping fee of \$15 will be added to the analysis invoice.
4. Not valid for the shipping of any hazardous materials or items prohibited to be shipped by these means.
5. Valid for only those accounts pre-approved to use this service. This courtesy shipping service may be terminated at any time by LA Testing for any customer accounts that are not in good standing due to late payment (COD Status, or any other reason in the sole determination of LA Testing.
6. Any additional fees, including, but not limited to, custom pickup fees from FedEx, excessive weight fees, and any surcharge items added by FedEx, associated with this label/package will be back-charged to the customer that made the shipment.
7. This label is not valid for weekend or holiday deliveries.
8. Excludes Summa Centers, Equipment Rental and Loaner Returns.
9. Valid in the Continental United States and within Canada.





# LA Testing

520 Mission Street South Pasadena, CA 91030  
Phone/Fax: (323) 254-9960 / (323) 254-9982  
<http://www.LATesting.com> / [pasadenalab@latesting.com](mailto:pasadenalab@latesting.com)

LA Testing Order: 321720371  
Customer ID: 32MYOU50  
Customer PO:  
Project ID:


**Attention:** Akari Ihara  
Myounghee Noh & Associates, LLC  
99-1046 Iwaena Street  
Suite 210A  
Aiea, HI 96701  
**Project:** Re-analysis 321720066 / 2388.3

**Phone:** (808) 358-1421  
**Fax:**  
**Received:** 08/25/2017 4:38 PM  
**Analysis Date:** 08/29/2017  
**Collected:**

## Test Report: Asbestos Analysis of Bulk Materials via EPA 600/R-93/116 Method using Polarized Light Microscopy. Quantitation using 400 Point Count Procedure

Sample	Description	Appearance	Non-Asbestos		Asbestos
			% Fibrous	% Non-Fibrous	% Type
2388.A3A-2388.A3 A-Cementitious Material 321720371-0001	Lut Floor - Beige	Brown/Gray Non-Fibrous Homogeneous		100% Non-fibrous (Other)	<0.25% Chrysotile
2388.A3B-2388.A3 A-Cementitious Material 321720371-0002	Lut Floor - Beige	Gray Non-Fibrous Homogeneous		100% Non-fibrous (Other)	<0.25% Chrysotile

Analyst(s)  
Kieu-anh Pham Duong (2)

  
Jerry Drapala Ph.D, Laboratory Manager  
or other approved signatory

Disclaimer: Some samples may contain asbestos fibers present in dimensions below PLM resolution limits. The limit of detection as stated in the method is 0.25%. EMSL Analytical Inc suggests that samples reported as <0.25% or none detected undergo additional analysis via TEM. The above test report relates only to the items tested. This report may not be reproduced, except in full, without written approval of EMSL Analytical Inc. This test report must not be used by the client to claim product endorsement by NVLAP or any agency of the United States Government. EMSL Analytical Inc., bears no responsibility for sample collection activities, analytical method limitations, or the accuracy of results when requested to separate layered samples. EMSL Analytical Inc., liability is limited to the cost of sample analysis. The test results contained within this report meet the requirements of NELAC unless otherwise noted. Samples received in good condition unless otherwise noted. Unless requested by the client, building materials manufactured with multiple layers (i.e. linoleum, wallboard, etc.) are reported as a single sample.

Samples analyzed by LA Testing South Pasadena, CA NVLAP Lab Code 200232-0

Initial report from: 08/29/2017 16:04:15

**Mulcahy, Brandon**

---

**From:** Akari Ihara <akari@noh-associates.com>  
**Sent:** Friday, August 25, 2017 4:38 PM  
**To:** Vong, Julie; LA Testing Lab - Pasadena  
**Subject:** RE: LA Testing report, COC for order(s) 321720066 (321720066 - 2388.3)

Aloha,  
Can we get a 400 point count on the 2388.A3A,B,C (<1%). With a three day TAT.

Thank you,

**From:** LA Testing (South Pasadena) [mailto:pasadenalab@latesting.com]  
**Sent:** Friday, August 25, 2017 11:34 AM  
**To:** Akari Ihara <akari@noh-associates.com>  
**Subject:** LA Testing report, COC for order(s) 321720066 (321720066 - 2388.3)

Report, COC for order(s):  
321720066 - 2388.3



**Julie Vong** | *Laboratory Analyst*

**LA Testing** | 520 Mission Street | South Pasadena, CA 91030  
Phone: 323-254-9960 | Fax: 323-254-9982 | Toll Free: 800-303-0047  
Lab Hours: Monday - Friday 8AM - 6PM, Saturday 9AM - 5PM, Sunday On-Call

Some of the resources LATesting, Inc. offers to our clients:

[LABConnect](#) | [Order Products](#) | [Client Corner](#) | [Training](#) | [Additional Resources](#) | [Sampling Videos](#)

---

"This email may contain privileged and confidential information and is solely for the use of the sender's intended recipient(s). **If you are not the intended recipient of this communication, you are hereby notified that any unauthorized review, use, dissemination, distribution, downloading, or copying of this communication is strictly prohibited.** If you received this email in error, please notify the sender by reply email and delete all copies and attachments. Thank you."



**LA Testing**

520 Mission Street South Pasadena, CA 91030  
 Tel/Fax: (323) 254-9960 / (323) 254-9982  
 http://www.LATesting.com / pasadenalab@latesting.com

LA Testing Order: 321720066  
 Customer ID: 32MYOU50  
 Customer PO:  
 Project ID:

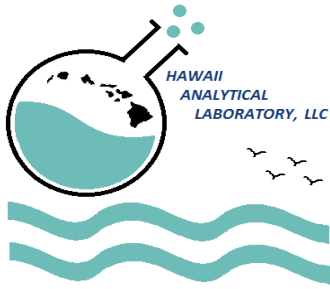
**Attention:** Akari Ihara  
 Myounghee Noh & Associates, LLC  
 99-1046 Iwaena Street  
 Suite 210A  
 Aiea, HI 96701  
**Project:** 2388.3

**Phone:** (808) 358-1421  
**Fax:**  
**Received Date:** 08/21/2017 9:20 AM  
**Analysis Date:** 08/25/2017  
**Collected Date:**

**Test Report: Asbestos Analysis of Bulk Materials via EPA 600/R-93/116 Method using Polarized Light Microscopy**

Sample	Description	Appearance	Non-Asbestos		Asbestos
			% Fibrous	% Non-Fibrous	% Type
2388.A1A 321720066-0001	Ext Roof System - P/SC	Gray Non-Fibrous Homogeneous		100% Non-fibrous (Other)	None Detected
2388.A1B 321720066-0002	Ext Roof System - P/SC	Green Non-Fibrous Homogeneous		100% Non-fibrous (Other)	None Detected
2388.A1C 321720066-0003	Ext Roof System - P/SC	Green/Beige Non-Fibrous Homogeneous		100% Non-fibrous (Other)	None Detected
2388.A2A 321720066-0004	Ext Vent - Gray cementitas	Gray Non-Fibrous Homogeneous		100% Non-fibrous (Other)	None Detected
2388.A2B 321720066-0005	Ext Vent - Gray cementitas	Gray Non-Fibrous Homogeneous		100% Non-fibrous (Other)	None Detected
2388.A2C 321720066-0006	Ext Vent - Gray cementitas	Gray Non-Fibrous Homogeneous		100% Non-fibrous (Other)	None Detected
2388.A3A-Coating 321720066-0007	Lut Floor - beige coating	Beige/Orange Non-Fibrous Homogeneous		100% Non-fibrous (Other)	None Detected
2388.A3A-Cementitious Material 321720066-0007A	Lut Floor - beige coating	Brown/Gray Non-Fibrous Homogeneous		100% Non-fibrous (Other)	<1% Chrysotile
2388.A3B-Coating 321720066-0008	Lut Floor - beige coating	Beige/Orange Non-Fibrous Homogeneous		100% Non-fibrous (Other)	None Detected
2388.A3B-Cementitious Material 321720066-0008A	Lut Floor - beige coating	Gray Non-Fibrous Homogeneous		100% Non-fibrous (Other)	<1% Chrysotile
2388.A3C 321720066-0009	Lut Floor - beige coating	Beige/Orange Non-Fibrous Homogeneous		100% Non-fibrous (Other)	None Detected
2388.A4A-Coating 321720066-0010	Lut Sealant Joint - beige asphalt base sealant	Orange Non-Fibrous Homogeneous		100% Non-fibrous (Other)	None Detected
2388.A4A-Texture 321720066-0010A	Lut Sealant Joint - beige asphalt base sealant	Gray Non-Fibrous Homogeneous		100% Non-fibrous (Other)	None Detected
2388.A4A-Tar 321720066-0010B	Lut Sealant Joint - beige asphalt base sealant	Black Non-Fibrous Homogeneous		100% Non-fibrous (Other)	None Detected
2388.A4B-Coating 321720066-0011	Lut Sealant Joint - beige asphalt base sealant	Orange Non-Fibrous Homogeneous		100% Non-fibrous (Other)	None Detected

Initial report from: 08/25/2017 14:24:05



# Hawaii Analytical Laboratory ANALYTICAL REPORT

Friday, August 25, 2017

Ms. Myounghee Noh  
 Myounghee Noh & Associates  
 99-1046 Iwaena St. Suite 210A  
 Aiea HI 96701

**Phone Number:** (808) 484-9214  
**Facsimile:** (808) 484-4660  
**Email:** m\_noh@noh-associates.com

**Lab Job No:** 20176765  
**Date Submitted:** 8/18/2017  
**Your Project:** DOW Kekaha 0.5 MG Tank, 8/17/2017

## Lead, total (paint chips)

NIOSH Method: 7082m LEAD by FAAS

Sample No.	Your Sample Description	Results	Units	Date Analyzed
201737463	2388-P1A	1200	mg/kg	8/23/2017
Comments				
201737464	2388-P1B	710	mg/kg	8/23/2017
Comments				
201737465	2388-P2A	55000	mg/kg	8/23/2017
Comments				
201737466	2388-P2B	41000	mg/kg	8/23/2017
Comments				
201737467	2388-P3A	1400	mg/kg	8/23/2017
Comments				
201737468	2388-P3B	1200	mg/kg	8/23/2017
Comments				
201737469	2388-P4A	41000	mg/kg	8/23/2017
Comments				
201737470	2388-P4B	40000	mg/kg	8/23/2017
Comments				

Hawaii Analytical Laboratory (101812) is accredited by the AIHA LAP, LLC in the EMLAP, IHLAP, and ELLAP programs for the scope of work listed on [www.aihaaccreditedlabs.org](http://www.aihaaccreditedlabs.org), in accordance with the recognized ISO/ IEC 17025:2005.  
 Controlled doc.: Lead Report, rev. 3 - 20161017

Ms. Myounghee Noh  
Myounghee Noh & Associates  
99-1046 Iwaena St. Suite 210A  
Aiea HI 96701

**Phone Number:** (808) 484-9214  
**Facsimile:** (808) 484-4660  
**Email:** m\_noh@noh-associates.com

**Lab Job No:** 20176765  
**Date Submitted:** 8/18/2017  
**Your Project:** DOW Kekaha 0.5 MG Tank, 8/17/2017

### Lead, total (paint chips)

NIOSH Method: 7082m LEAD by FAAS

Sample No.	Your Sample Description	Results	Units	Date Analyzed
201737471	2388-P5A	< 40	mg/kg	8/23/2017
Comments				
201737472	2388-P5B	< 40	mg/kg	8/23/2017
Comments				
201737473	2388-P6A	< 40	mg/kg	8/23/2017
Comments				
201737474	2388-P6B	< 40	mg/kg	8/23/2017
Comments				


All Quality Control data are acceptable unless otherwise noted.  
MRL for lead air is 5ug.  
MRL for lead wipe is 10ug.  
MRL for lead paint or soil is 40 mg/kg for a 0.25g sample.

#### General Comments

The sample[s] analysis subject of this analytical report were conducted in general accordance with the procedures associated with the "analytical method" referenced above. Modifications to this methodology may have been made based upon the analyst's professional judgment and / or sample matrix effects encountered. The analysis of sample relates only to the sample analyzed, and may or may not be representative of the original source of the material submitted for our analysis. All analysts participate in interlaboratory quality control testing to continuously document proficiency. This report is not to be duplicated except in full without the expressed written permission of Hawaii Analytical Laboratory. This report should not be construed as an endorsement for a product or a service by the AIHA LAP, LLC or any affiliated organizations. Sample and associated sampling / collection data is reported as provided by client. TWA values have been calculated based on information supplied by the client that the laboratory has not independently verified. Results have not been corrected for blank determinations unless noted in remarks. Unless otherwise indicated the sample condition at the time of receipt was acceptable.

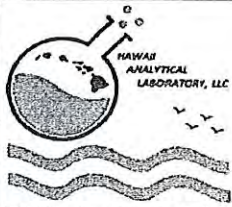
#### Results and Symbols Definitions

> This testing result is greater than the numerical value listed.  
< This testing result is less than the numerical value listed.  
# = Analytical methods marked with an "#" are not within our AIHA LAP, LLC Scope of Accreditation.  
MRL = Method Reporting Limit.



**Jennifer Hsu Liao**  
**Laboratory Manager**

Hawaii Analytical Laboratory (101812) is accredited by the AIHA LAP, LLC in the EMLAP, IHLAP, and ELLAP programs for the scope of work listed on [www.aihaaccreditedlabs.org](http://www.aihaaccreditedlabs.org), in accordance with the recognized ISO/ IEC 17025:2005.  
Controlled doc.: Lead Report, rev. 3 - 20161017



3615 Harding Avenue, Suite 308  
 Honolulu, HI 96816  
 PH: 808-735-0422  
 FAX: 808-735-0047

**Need Results By\*:**

- 5 Working Days
- 4 Working Days
- 72 hour
- 48 hour
- 24 Hour
- Rush - 6 hours
- Immediate - 4 hrs or less

New Client?

Report To\* : Myounghee Noh  
 Company : Myounghee Noh & Associates, LLC  
 Address\* : 99-1046 Iwaena Street, 210A  
 Aiea, HI 96701  
 Phone / Cell No.\* : 808-484-9214  
 Report results to :  
 via email or fax :  
 or verbal: :

Invoice To\* : Myounghee Noh & Associates, LLC  
 Company :  
 Address\* : 99-1046 Iwaena Street, 210A  
 Aiea, HI 96701  
 Phone / Cell No.\* : 808-484-9214  
 Purchase Order No. :  
 Email Invoice To :

Site/Project Name: DOW Kekaha 0.5 MG Tank Client Project No.: 2388.2 Sampled By: AI

Comments / Special Instructions:

PLM POSITIVE STOP Instructions:

- Positive stop per SAMPLE
- Positive stop per LAYER

**LAB USE ONLY**

Lab Report No.:  
**20176765**

Sample Identification* (Maximum of 30 Characters)	Date Sampled* (mm/dd/yy)	Collection Medium	Sample Area / Air Volume	Analysis Requested*	Method Reference	Lab ID
<u>2388-PIA</u> <u>L ↓ B</u>	<u>8.17.17</u>	<u>PoChrp</u>	<u>NA</u>	<u>PoChrp</u>		
<u>2388-PIA</u> <u>L ↓ B</u>						

Relinquished By (Print and Sign) 	Date/Time <u>1 8.18.17</u>	Received By (Print and Sign) <u>Anne Antin</u>	Date/Time <u>08-18-17 P01:44 RCVD</u>
--------------------------------------	-------------------------------	---	--

Sample description can be paint chips, concrete, specific sample collection location, etc...  
 If matrix is 'soil', please specify if it is a FOREIGN SOIL SAMPLE (outside Hawaii) in the comment section.  
 All samples submitted are subject to Hawaii Analytical Laboratory terms and conditions.  
 \*Required fields, failure to complete these fields may result in a delay in your samples being processed.  
 Rev 20140701

### Hazardous Homogeneous Materials and Sampling Survey Field Form: Lead Paint

6765

Project Number: 2388 3 Location: DOW Kekaha 0.5MG Storage Tank

Inspector Initials: AI

Survey Dates and Times: 8.17.17

HM ID	Building	Flr.	Rooms	Locations	Material Color	Material	Substrate	Condition	Area Sq. ft or L. ft	Hatch Color
1	0.5MG Res Tank	R	ext	Roofing System	lt blue	P	CC	GⓅP	2,000 1700	
Sample ID		Room Sampled		Sample Location		PIC ID		Notes		
2388-P 1 A		ext 201737463		Roofing system		1489				
2388-P 1 B		↓ 201737464		↓						
HM ID	Building	Flr.	Rooms	Locations	Material Color	Material	Substrate	Condition	Area Sq. ft or L. ft	Hatch Color
2 4	0.5MG Tank	R	ext	Hatch	Dark Green	P	M	GⓅP	5	
Sample ID		Room Sampled		Sample Location		PIC ID		Notes		
2388-P 2 A		ext 201737465		Hatch		1492				
2388-P 2 B		↓ 201737466		↓						
HM ID	Building	Flr.	Rooms	Locations	Material Color	Material	Substrate	Condition	Area Sq. ft or L. ft	Hatch Color
5	0.5MG Tank	R	BA	handrail, ladder	lt green	P	M	GⓅP	20	
Sample ID		Room Sampled		Sample Location		PIC ID		Notes		
2388-P 3 A		ext 201737467		handrail		1495				
2388-P 3 B		↓ 201737468		ladder						

**Hazardous Homogeneous Materials and Sampling Survey Field Form: Lead Paint**

Project Number: 2388 3 Location: DOW Kekaha 0.5MG Storage Tank Inspector Initials: AI Survey Dates and Times: 8.17.17

HM ID	Building	Flr.	Rooms	Locations	Material Color	Material	Substrate	Condition	Area Sq. ft or L. ft	Hatch Color
6	0.5MG Tank	1	Int	Floor	beige	coating	CC	G F (P)	5,000	Same as HM7

Sample ID	Room Sampled	Sample Location	PIC ID	Notes
2388-P 4 A	Int 201737469	Floor	1501	
2388-P 4 B	↓ 201737470	↓		

HM ID	Building	Flr.	Rooms	Locations	Material Color	Material	Substrate	Condition	Area Sq. ft or L. ft	Hatch Color
10		1	Ext	walls	gray	P	CC	G F (P)	10,000	Same as HM10

Sample ID	Room Sampled	Sample Location	PIC ID	Notes
2388-P 5 A	ext 201737471	walls	1509	
2388-P 5 B	↓ 201737472	↓		

HM ID	Building	Flr.	Rooms	Locations	Material Color	Material	Substrate	Condition	Area Sq. ft or L. ft	Hatch Color
11		1	Ext	walls	beige	P	CC	G F (P)	5,000	

Sample ID	Room Sampled	Sample Location	PIC ID	Notes
2388-P 6 A	ext 201737473	walls	1509	
2388-P 6 B	↓ 201737474	↓		





**EMSL Analytical, Inc.**

200 Route 130 North, Cinnaminson, NJ 08077

Phone: (856) 303-2500 Fax: (856) 858-4571 Email: EnvChemistry2@emsl.com

Attn:

**Akari Ihara**  
**Myounghee Noh & Associates, LLC**  
**99-1046 Iwaena Street**  
**Suite 210A**  
**Aiea, HI 96701**

Phone: (808) 484-9214

Fax:

9/11/2017

The following analytical report covers the analysis performed on samples submitted to EMSL Analytical, Inc. on 8/23/2017. The results are tabulated on the attached data pages for the following client designated project:

**2388.3**

The reference number for these samples is EMSL Order #011706838. Please use this reference when calling about these samples. If you have any questions, please do not hesitate to contact me at (856) 303-2500.

Approved By:

Phillip Worby, Environmental Chemistry  
Laboratory Director



The test results contained within this report meet the requirements of NELAP and/or the specific certification program that is applicable, unless otherwise noted.  
NELAP Certifications: NJ 03036, NY 10872, PA 68-00367, CA ELAP 1877

The samples associated with this report were received in good condition unless otherwise noted. This report relates only to those items tested as received by the laboratory. The QC data associated with the sample results meet the recovery and precision requirements established by the NELAP, unless specifically indicated. All results for soil samples are reported on a dry weight basis, unless otherwise noted. This report may not be reproduced except in full and without written approval by EMSL Analytical, Inc.

**EMSL Analytical, Inc.**

200 Route 130 North, Cinnaminson, NJ 08077  
 Phone/Fax: (856) 303-2500 / (856) 858-4571  
<http://www.EMSL.com> [EnvChemistry2@emsl.com](mailto:EnvChemistry2@emsl.com)

EMSL Order: 011706838  
 CustomerID: 32MYOU50  
 CustomerPO:  
 ProjectID:

Attn: **Akari Ihara**  
**Myounghee Noh & Associates, LLC**  
**99-1046 Iwaena Street**  
**Suite 210A**  
**Aiea, HI 96701**

Phone: (808) 484-9214  
 Fax:  
 Received: 08/23/17 9:15 AM

Project: 2388.3

**Analytical Results**

**Client Sample Description** 2388.PCB1-A,B,C **Collected:** 8/18/2017 **Lab ID:** 011706838-0001

Method	Parameter	Result	RL	Units	Prep Date	Analyst	Analysis Date	Analyst
3540C/8082A	Aroclor-1016	ND	0.79	mg/Kg	9/7/2017	AB	9/11/2017	EH
3540C/8082A	Aroclor-1221	ND	0.79	mg/Kg	9/7/2017	AB	9/11/2017	EH
3540C/8082A	Aroclor-1232	ND	0.79	mg/Kg	9/7/2017	AB	9/11/2017	EH
3540C/8082A	Aroclor-1242	2.3	0.79	mg/Kg	9/7/2017	AB	9/11/2017	EH
3540C/8082A	Aroclor-1248	ND	0.79	mg/Kg	9/7/2017	AB	9/11/2017	EH
3540C/8082A	Aroclor-1254	8.1	0.79	mg/Kg	9/7/2017	AB	9/11/2017	EH
3540C/8082A	Aroclor-1260	18	0.79	mg/Kg	9/7/2017	AB	9/11/2017	EH
3540C/8082A	Aroclor-1262	ND	0.79	mg/Kg	9/7/2017	AB	9/11/2017	EH
3540C/8082A	Aroclor-1268	ND	0.79	mg/Kg	9/7/2017	AB	9/11/2017	EH

**Client Sample Description** 2388.PCB2-A,B,C **Collected:** 8/18/2017 **Lab ID:** 011706838-0002

Method	Parameter	Result	RL	Units	Prep Date	Analyst	Analysis Date	Analyst
3540C/8082A	Aroclor-1016	ND	0.82	mg/Kg	9/7/2017	AB	9/8/2017	EH
3540C/8082A	Aroclor-1221	ND	0.82	mg/Kg	9/7/2017	AB	9/8/2017	EH
3540C/8082A	Aroclor-1232	ND	0.82	mg/Kg	9/7/2017	AB	9/8/2017	EH
3540C/8082A	Aroclor-1242	2.4	0.82	mg/Kg	9/7/2017	AB	9/8/2017	EH
3540C/8082A	Aroclor-1248	ND	0.82	mg/Kg	9/7/2017	AB	9/8/2017	EH
3540C/8082A	Aroclor-1254	3.4	0.82	mg/Kg	9/7/2017	AB	9/8/2017	EH
3540C/8082A	Aroclor-1260	4.7	0.82	mg/Kg	9/7/2017	AB	9/8/2017	EH
3540C/8082A	Aroclor-1262	ND	0.82	mg/Kg	9/7/2017	AB	9/8/2017	EH
3540C/8082A	Aroclor-1268	ND	0.82	mg/Kg	9/7/2017	AB	9/8/2017	EH

**Client Sample Description** 2388.PCB3-A,B,C **Collected:** 8/18/2017 **Lab ID:** 011706838-0003

Method	Parameter	Result	RL	Units	Prep Date	Analyst	Analysis Date	Analyst
3540C/8082A	Aroclor-1016	ND	4.7	mg/Kg	9/7/2017	AB	9/11/2017	EH
3540C/8082A	Aroclor-1221	ND	4.7	mg/Kg	9/7/2017	AB	9/11/2017	EH
3540C/8082A	Aroclor-1232	ND	4.7	mg/Kg	9/7/2017	AB	9/11/2017	EH
3540C/8082A	Aroclor-1242	ND	4.7	mg/Kg	9/7/2017	AB	9/11/2017	EH
3540C/8082A	Aroclor-1248	ND	4.7	mg/Kg	9/7/2017	AB	9/11/2017	EH
3540C/8082A	Aroclor-1254	38	4.7	mg/Kg	9/7/2017	AB	9/11/2017	EH
3540C/8082A	Aroclor-1260	76	4.7	mg/Kg	9/7/2017	AB	9/11/2017	EH
3540C/8082A	Aroclor-1262	ND	4.7	mg/Kg	9/7/2017	AB	9/11/2017	EH
3540C/8082A	Aroclor-1268	ND	4.7	mg/Kg	9/7/2017	AB	9/11/2017	EH



## EMSL Analytical, Inc.

200 Route 130 North, Cinnaminson, NJ 08077

Phone/Fax: (856) 303-2500 / (856) 858-4571

<http://www.EMSL.com>

[EnvChemistry2@emsl.com](mailto:EnvChemistry2@emsl.com)

EMSL Order:	011706838
CustomerID:	32MYOU50
CustomerPO:	
ProjectID:	

### Definitions:

ND - indicates that the analyte was not detected at the reporting limit

RL - Reporting Limit (Analytical)



# Asbestos Chain of Custody

EMSL Order Number (Lab Use Only):

011706838

LATESTING  
520 MISSION STREET  
SOUTH PASADENA, CA 91030  
PHONE: (800)-303-0047  
FAX: (323)-254-9962

Company : Myounghee Noh & Associates L.L.C		EMSL-Bill to: <input type="checkbox"/> Same <input type="checkbox"/> Different If Bill to is Different note instructions in Comments**	
Street: 99-1046 Iwaena St.		Third Party Billing requires written authorization from third party	
City: Aiea	State/Province: Hawaii	Zip/Postal Code:	Country:
Report To (Name): AKari		Telephone #:	
Email Address:		Fax #:	Purchase Order:
Project Name/Number: 2388.3		Please Provide Results: <input type="checkbox"/> Fax <input type="checkbox"/> Email <input type="checkbox"/> Mail	
U.S. State Samples Taken: 4		Connecticut Samples: <input type="checkbox"/> Commercial <input type="checkbox"/> Residential	

Turnaround Time (TAT) Options\* - Please Check

3 Hour  6 Hour  24 Hour  48 Hour  72 Hour  96 Hour  1 Week  2 Week

\*For TEM Air 3 hr through 6 hr, please call ahead to schedule. \*There is a premium charge for 3 Hour TEM AHERA or EPA Level II TAT. You will be asked to sign an authorization form for this service. Analysis completed in accordance with EMSL's Terms and Conditions located in the Analytical Price Guide.

<b>PCM - Air</b> <input type="checkbox"/> Check if samples are from NY <input type="checkbox"/> NIOSH 7400 <input type="checkbox"/> w/ OSHA 8hr. TWA	<b>TEM - Air</b> <input type="checkbox"/> 4-4.5hr TAT (AHERA only) <input type="checkbox"/> AHERA 40 CFR, Part 763 <input type="checkbox"/> NIOSH 7402 <input type="checkbox"/> EPA Level II <input type="checkbox"/> ISO 10312	<b>TEM - Dust</b> <input type="checkbox"/> Microvac - ASTM D 5755 <input type="checkbox"/> Wipe - ASTM D6480 <input type="checkbox"/> Carpet Sonication (EPA 600/J-93/167)
<b>PLM - Bulk (reporting limit)</b> <input type="checkbox"/> PLM EPA 600/R-93/116 (<1%) <input type="checkbox"/> PLM EPA NOB (<1%) Point Count <input type="checkbox"/> 400 (<0.25%) <input type="checkbox"/> 1000 (<0.1%) Point Count w/Gravimetric <input type="checkbox"/> 400 (<0.25%) <input type="checkbox"/> 1000 (<0.1%) <input type="checkbox"/> NYS 198.1 (friable in NY) <input type="checkbox"/> NYS 198.6 NOB (non-friable-NY) <input type="checkbox"/> NIOSH 9002 (<1%)	<b>TEM - Bulk</b> <input type="checkbox"/> TEM EPA NOB <input type="checkbox"/> NYS NOB 198.4 (non-friable-NY) <input type="checkbox"/> Chatfield SOP <input type="checkbox"/> TEM Mass Analysis-EPA 600 sec. 2.5	<b>Soil/Rock/Vermiculite</b> <input type="checkbox"/> PLM CARB 435 - A (0.25% sensitivity) <input type="checkbox"/> PLM CARB 435 - B (0.1% sensitivity) <input type="checkbox"/> TEM CARB 435 - B (0.1% sensitivity) <input type="checkbox"/> TEM CARB 435 - C (0.01% sensitivity) <input type="checkbox"/> TEM Qual. via Filtration Technique <input type="checkbox"/> TEM Qual. via Drop-Mount Technique
<input type="checkbox"/> Check For Positive Stop - Clearly Identify Homogenous Group		<b>Filter Pore Size (Air Samples):</b> <input type="checkbox"/> 0.8µm <input type="checkbox"/> 0.45µm

Samplers Name: AKari Samplers Signature: [Signature]

Comp or separate?  
 (1)  
 (2)  
 (3)

Sample #	Sample Description	Volume/Area (Air) HA # (Bulk)	Date/Time Sampled
2388-PCB1A	Bulk		
↓ ↓ ↓			
2388-PCB3A			
↓ ↓ ↓			

Client Sample # (s): 2388-PCB1A ~ 2388-PCB3C Total # of Samples: 6

Relinquished (Client): [Signature] Date: 8-18-17 Time:

Received (Lab): DF Lores (EMSL FedEx) Date: 8/21/17 Time: 9:20am

Comments/Special Instructions:  
 Rec: FE (EV) 8.22.17 Relinquished: [Signature] 8.22.17

\*After AKari: proceed w/ samples as composite at 3 day TAT on 9/6 14:30

09:15 \*Pasadena Lab sent corresponding samples to supplement for composite analysis on 9/6

011706838

**Hazardous Homogeneous Materials and Sampling Survey Field Form: PCB Bulk**

6.17.17

Project Number: 2388 3 Location: DOW Kekaha 0.5MG Storage Tank Inspector Initials: AI Survey Dates and Times:

HM ID	Building	Fir.	Rooms	Locations	Material Color	Material	Substrate	Condition	Friable ACM Type	Area Sq. ft of L. ft	Hatch Color	Notes
12	0.5 MG Tank	1	Int	Floor + doors Sealant J	Berg	Coating Asphalt Sealant	CC	GFP	Y TSI S M	1000	Same as HMG	
2388-PCB 1 A			Int	Floor + doors		1501						
2388-PCB 1 B						1501						
2388-PCB 1 C												
13	0.5 MG Tank	1	Int	Sealant joint	Berg	Asphalt base sealant	CC	GFP	Y TSI S M	1000	Same HMG	
2388-PCB 2 A						1501						
2388-PCB 2 B												
2388-PCB 2 C												
14	0.5 MG Tank	1	Int	walls	Blk	Coating	CC	GFP	Y TSI S M	10000	Same as HMG	
2388-PCB 3 A			Int	walls		1501						
2388-PCB 3 B												
2388-PCB 3 C												

011706838

**Hazardous Homogeneous Materials and Sampling Survey Field Form: PCB Bulk**

6.17.17

Project Number: 2388 3 Location: DOW Kekaha 0.5MG Storage Tank Inspector Initials: AI Survey Dates and Times:

HM ID	Building	Fir.	Rooms	Locations	Material Color	Material	Substrate	Condition	Friable ACM Type	Area Sq. ft of L. ft	Hatch Color																				
12	0.5 MG Tank	1	Int	floor + drains sealant	Beige	Coating	CC	GFP	Y TSI S M	1000	Same as HMG																				
<table border="1"> <thead> <tr> <th>Sample ID</th> <th>Room Sampled</th> <th>Sample Location</th> <th>PIC ID</th> <th>Notes</th> </tr> </thead> <tbody> <tr> <td>2388-PCB 1 A</td> <td>Int</td> <td>floor + drains</td> <td>1501</td> <td></td> </tr> <tr> <td>2388-PCB 1 B</td> <td>↓</td> <td>↓</td> <td>1501</td> <td></td> </tr> <tr> <td>2388-PCB 1 C</td> <td></td> <td></td> <td></td> <td></td> </tr> </tbody> </table>												Sample ID	Room Sampled	Sample Location	PIC ID	Notes	2388-PCB 1 A	Int	floor + drains	1501		2388-PCB 1 B	↓	↓	1501		2388-PCB 1 C				
Sample ID	Room Sampled	Sample Location	PIC ID	Notes																											
2388-PCB 1 A	Int	floor + drains	1501																												
2388-PCB 1 B	↓	↓	1501																												
2388-PCB 1 C																															
13	0.5 MG Tank	1	Int	sealant joint	Beige	Asphalt long sealant	CC	GFP	Y TSI S M	1000	Same HMG																				
<table border="1"> <thead> <tr> <th>Sample ID</th> <th>Room Sampled</th> <th>Sample Location</th> <th>PIC ID</th> <th>Notes</th> </tr> </thead> <tbody> <tr> <td>2388-PCB 2 A</td> <td></td> <td></td> <td>1501</td> <td></td> </tr> <tr> <td>2388-PCB 2 B</td> <td></td> <td></td> <td></td> <td></td> </tr> <tr> <td>2388-PCB 2 C</td> <td></td> <td></td> <td></td> <td></td> </tr> </tbody> </table>												Sample ID	Room Sampled	Sample Location	PIC ID	Notes	2388-PCB 2 A			1501		2388-PCB 2 B					2388-PCB 2 C				
Sample ID	Room Sampled	Sample Location	PIC ID	Notes																											
2388-PCB 2 A			1501																												
2388-PCB 2 B																															
2388-PCB 2 C																															
14	0.5 MG Tank	1	Int	walls	Blk	Coating	CC	GFP	Y TSI S M	1000	Same as HMG																				
<table border="1"> <thead> <tr> <th>Sample ID</th> <th>Room Sampled</th> <th>Sample Location</th> <th>PIC ID</th> <th>Notes</th> </tr> </thead> <tbody> <tr> <td>2388-PCB 3 A</td> <td>Int</td> <td>walls</td> <td>1501</td> <td></td> </tr> <tr> <td>2388-PCB 3 B</td> <td></td> <td></td> <td></td> <td></td> </tr> <tr> <td>2388-PCB 3 C</td> <td></td> <td></td> <td></td> <td></td> </tr> </tbody> </table>												Sample ID	Room Sampled	Sample Location	PIC ID	Notes	2388-PCB 3 A	Int	walls	1501		2388-PCB 3 B					2388-PCB 3 C				
Sample ID	Room Sampled	Sample Location	PIC ID	Notes																											
2388-PCB 3 A	Int	walls	1501																												
2388-PCB 3 B																															
2388-PCB 3 C																															



**EMSL Analytical, Inc.**

200 Route 130 North, Cinnaminson, NJ 08077

Phone: (856) 303-2500 Fax: (856) 858-4571 Email: EnvChemistry2@emsl.com

---

Attn:

**Akari Ihara**  
**Myounghee Noh & Associates, LLC**  
**99-1046 Iwaena Street**  
**Suite 210A**  
**Aiea, HI 96701**

10/25/2017

Phone: (808) 484-9214

Fax:

The following analytical report covers the analysis performed on samples submitted to EMSL Analytical, Inc. on 10/23/2017. The results are tabulated on the attached data pages for the following client designated project:

**2388-3**

The reference number for these samples is EMSL Order #011708485. Please use this reference when calling about these samples. If you have any questions, please do not hesitate to contact me at (856) 303-2500.

Approved By:

---

Phillip Worby, Environmental Chemistry  
Laboratory Director



The test results contained within this report meet the requirements of NELAP and/or the specific certification program that is applicable, unless otherwise noted.  
NELAP Certifications: NJ 03036, NY 10872, PA 68-00367, CA ELAP 1877

The samples associated with this report were received in good condition unless otherwise noted. This report relates only to those items tested as received by the laboratory. The QC data associated with the sample results meet the recovery and precision requirements established by the NELAP, unless specifically indicated. All results for soil samples are reported on a dry weight basis, unless otherwise noted. This report may not be reproduced except in full and without written approval by EMSL Analytical, Inc.

**EMSL Analytical, Inc.**

200 Route 130 North, Cinnaminson, NJ 08077

Phone/Fax: (856) 303-2500 / (856) 858-4571

<http://www.EMSL.com>[EnvChemistry2@emsl.com](mailto:EnvChemistry2@emsl.com)

EMSL Order:	011708485
CustomerID:	32MYOU50
CustomerPO:	
ProjectID:	

Attn: **Akari Ihara**  
**Myounghee Noh & Associates, LLC**  
**99-1046 Iwaena Street**  
**Suite 210A**  
**Aiea, HI 96701**

Phone: (808) 484-9214  
 Fax:  
 Received: 10/23/17 9:15 AM

Project: 2388-3

**Analytical Results**

**Client Sample Description** 2388-PCB4A **Collected:** 10/19/2017 **Lab ID:** 011708485-0001  
 Interior Coating 0.5 MG Tank

Method	Parameter	Result	RL	Units	Prep Date	Analyst	Analysis Date	Analyst
3540C/8082A	Aroclor-1016	ND	20	mg/Kg	10/24/2017	SD	10/25/2017	EH
3540C/8082A	Aroclor-1221	ND	20	mg/Kg	10/24/2017	SD	10/25/2017	EH
3540C/8082A	Aroclor-1232	ND	20	mg/Kg	10/24/2017	SD	10/25/2017	EH
3540C/8082A	Aroclor-1242	ND	20	mg/Kg	10/24/2017	SD	10/25/2017	EH
3540C/8082A	Aroclor-1248	ND	20	mg/Kg	10/24/2017	SD	10/25/2017	EH
3540C/8082A	Aroclor-1254	73	20	mg/Kg	10/24/2017	SD	10/25/2017	EH
3540C/8082A	Aroclor-1260	210	20	mg/Kg	10/24/2017	SD	10/25/2017	EH
3540C/8082A	Aroclor-1262	ND	20	mg/Kg	10/24/2017	SD	10/25/2017	EH
3540C/8082A	Aroclor-1268	ND	20	mg/Kg	10/24/2017	SD	10/25/2017	EH

**Client Sample Description** 2388-PCB4B **Collected:** 10/19/2017 **Lab ID:** 011708485-0002  
 Interior Coating 0.5 MG Tank

Method	Parameter	Result	RL	Units	Prep Date	Analyst	Analysis Date	Analyst
3540C/8082A	Aroclor-1016	ND	19	mg/Kg	10/24/2017	SD	10/25/2017	EH
3540C/8082A	Aroclor-1221	ND	19	mg/Kg	10/24/2017	SD	10/25/2017	EH
3540C/8082A	Aroclor-1232	ND	19	mg/Kg	10/24/2017	SD	10/25/2017	EH
3540C/8082A	Aroclor-1242	ND	19	mg/Kg	10/24/2017	SD	10/25/2017	EH
3540C/8082A	Aroclor-1248	ND	19	mg/Kg	10/24/2017	SD	10/25/2017	EH
3540C/8082A	Aroclor-1254	51	19	mg/Kg	10/24/2017	SD	10/25/2017	EH
3540C/8082A	Aroclor-1260	170	19	mg/Kg	10/24/2017	SD	10/25/2017	EH
3540C/8082A	Aroclor-1262	ND	19	mg/Kg	10/24/2017	SD	10/25/2017	EH
3540C/8082A	Aroclor-1268	ND	19	mg/Kg	10/24/2017	SD	10/25/2017	EH

**Client Sample Description** 2388-PCB4C **Collected:** 10/19/2017 **Lab ID:** 011708485-0003  
 Interior Coating 0.5 MG Tank

Method	Parameter	Result	RL	Units	Prep Date	Analyst	Analysis Date	Analyst
3540C/8082A	Aroclor-1016	ND	14	mg/Kg	10/24/2017	SD	10/25/2017	EH
3540C/8082A	Aroclor-1221	ND	14	mg/Kg	10/24/2017	SD	10/25/2017	EH
3540C/8082A	Aroclor-1232	ND	14	mg/Kg	10/24/2017	SD	10/25/2017	EH
3540C/8082A	Aroclor-1242	ND	14	mg/Kg	10/24/2017	SD	10/25/2017	EH
3540C/8082A	Aroclor-1248	ND	14	mg/Kg	10/24/2017	SD	10/25/2017	EH
3540C/8082A	Aroclor-1254	39	14	mg/Kg	10/24/2017	SD	10/25/2017	EH
3540C/8082A	Aroclor-1260	170	14	mg/Kg	10/24/2017	SD	10/25/2017	EH
3540C/8082A	Aroclor-1262	ND	14	mg/Kg	10/24/2017	SD	10/25/2017	EH
3540C/8082A	Aroclor-1268	ND	14	mg/Kg	10/24/2017	SD	10/25/2017	EH





## EMSL Analytical, Inc.

200 Route 130 North, Cinnaminson, NJ 08077

Phone/Fax: (856) 303-2500 / (856) 858-4571

<http://www.EMSL.com>

[EnvChemistry2@emsl.com](mailto:EnvChemistry2@emsl.com)

EMSL Order:	011708485
CustomerID:	32MYOU50
CustomerPO:	
ProjectID:	

### Definitions:

ND - indicates that the analyte was not detected at the reporting limit

RL - Reporting Limit (Analytical)



### Asbestos Chain of Custody

EMSL Order Number (Lab Use Only):

011708485

LATESTING  
 520 MISSION STREET  
 SOUTH PASADENA, CA 91030  
 PHONE: (800) 303-0047  
 FAX: (323) 254-9962

RECEIVED  
 CHINA EMSI  
 17 OCT 2017 AM 9:21

Company: Myounghee Noh & Associates L.L.C  
 Street: 99-1046 Iwaena St.  
 City: Aiea State/Province: Hawaii Zip/Postal Code: 96701 Country: U.S.A.  
 Report To (Name): Akari Ihara Telephone #: 808-480-9214  
 Email Address: akari@noh-associates.com Fax #: Purchase Order: 2388.3  
 Project Name/Number: 2388-3 Please Provide Results:  Fax  Email  Mail  
 U.S. State Samples Taken: Hawaii Connecticut Samples:  Commercial  Residential

Turnaround Time (TAT) Options\* - Please Check  
 3 Hour  6 Hour  24 Hour  48 Hour  72 Hour  96 Hour  1 Week  2 Week

\*For TEM Air 3 hr through 6 hr, please call ahead to schedule. \*There is a premium charge for 3 Hour TEM AHERA or EPA Level II TAT. You will be asked to sign an authorization form for this service. Analysis completed in accordance with EMSL's Terms and Conditions located in the Analytical Price Guide.

PCM - Air  Check if samples are from NY  
 NIOSH 7400  w/ OSHA 8hr. TWA  
 PLM - Bulk (reporting limit)  
 PLM EPA 600/R-93/116 (<1%)  
 PLM EPA NOB (<1%)  
 Point Count  
 400 (<0.25%)  1000 (<0.1%)  
 Point Count w/Gravimetric  
 400 (<0.25%)  1000 (<0.1%)  
 NYS 198.1 (friable in NY)  
 NYS 198.6 NOB (non-friable-NY)  
 NIOSH 9002 (<1%)

TEM - Air  4-4.5hr TAT (AHERA only)  
 AHERA 40 CFR, Part 763  
 NIOSH 7402  
 EPA Level II  
 ISO 10312

TEM - Bulk  
 TEM EPA NOB  
 NYS NOB 198.4 (non-friable-NY)  
 Chatfield SOP  
 TEM Mass Analysis-EPA 600 sec. 2.5

TEM - Water: EPA 100.2  
 Fibers >10µm  Waste  Drinking  
 All Fiber Sizes  Waste  Drinking

TEM - Dust  
 Microvac - ASTM D 5755  
 Wipe - ASTM D6480  
 Carpet Sonication (EPA 600/J-93/167)

Soil/Rock/Vermiculite  
 PLM CARB 435 - A (0.25% sensitivity)  
 PLM CARB 435 - B (0.1% sensitivity)  
 TEM CARB 435 - B (0.1% sensitivity)  
 TEM CARB 435 - C (0.01% sensitivity)  
 TEM Qual. via Filtration Technique  
 TEM Qual. via Drop-Mount Technique

Other:  
 PCB Bulk

Check For Positive Stop - Clearly Identify Homogenous Group Filter Pore Size (Air Samples):  0.8µm  0.45µm

Samplers Name: Danny Falanag Samplers Signature: [Signature] for Danny

Sample #	Sample Description	Volume/Area (Air) HA # (Bulk)	Date/Time Sampled
① 2388-PCB 4A	Interior coating 0.5 MG Tank	16 bulk	10/19/2017
② 2388-PCB 4B	↓	↓	↓
③ 2388-PCB 4C	↓	↓	↓

Client Sample # (s): 2388-PCB 4A - 4C Total # of Samples: 3

Relinquished (Client): Myounghee Noh Date: 10/19/2017 Time: 12:00

Received (Lab): [Signature] 21.5 Date: 10/23/17 Time: 09:15

Comments/Special Instructions:  
 Separate the black coating material please. Analyze black coating and the remaining bulk material separately. Myounghee Noh 10/19/2017 myounghee@noh-associates.com

\*per client: analyze entire sample

\*Rec'd in plastic (af) [Signature]



**UNITED STATES ENVIRONMENTAL PROTECTION AGENCY**

REGION IX  
75 Hawthorne Street  
San Francisco, CA 94105-3901

**OCT 16 2018**

Mr. Jerry S. Fujita  
Structural Engineer  
KAI Hawaii, Inc.  
50 S. Beretania Street #C-119C  
Honolulu, Hawaii 96813

**Re: USEPA Conditional Approval of PCB Cleanup Plan under TSCA 761.61(c) for Paua Valley Tank #1, Kekaha, Kauai, Hawaii**

Dear Mr. Fujita:

Thank you for working with the U.S. Environmental Protection Agency, Region 9 ("USEPA") to address the disposal of polychlorinated biphenyls ("PCBs") found in the County of Kauai Department of Water ("DOW") Paua Valley 0.5-million-gallon concrete drinking water Tank #1 located at Tax Map Key (4) 1-2-002:039, Kekaha, Kauai, Hawaii (the "Site"). USEPA has received and reviewed the "Risk-Based PCB Cleanup Approval Application" (the "Workplan") dated September 18, 2018 that was prepared by KAI Hawaii, Inc. ("KAI Hawaii") on behalf of DOW, which outlines DOW's plan for drainage of the tank and disposal of floating oil containing PCBs.

Paua Valley Tank #1 is located on the southwest side of the island of Kauai, on a slope above the town of Kekaha. The Site is owned by the state of Hawaii with an executive order to DOW for well and water tank purposes. A hazardous materials survey of the tank was conducted in 2017, and the coal tar lining and joint sealant were found to have PCB levels up to 283 ppm. Water in the tank was sampled at the entry point to the water system, and the result was non-detect (i.e., less than or equal to the method detection limit of 0.1 ppb). The tank is currently off-line.

The Workplan describes an approach to drain the tank and dispose of oil currently floating in a thin layer at the top of the water tank consistent with Toxic Substances Control Act ("TSCA") standards. The oily layer has been sampled for PCBs, and the result was 13 ug/L (ppb). However, since water was likely entrained in the sample, disposal is conditioned on a follow-up oil sample with improved water removal, and on PCB levels in carbon filtration media.

Following drainage of the tank, DOW will not need USEPA approval to (1) remove the PCB coating (and/or PCB caulking) from the inside of the tank, (2) recoat the interior tank surfaces after PCB coating removal, and (3) dispose of the PCB coating material consistent with all applicable TSCA PCB disposal requirements (including and not limited to requirements in 40 C.F.R. § 761.62(a) and 40 C.F.R. § 761.205, "Notification of PCB waste activity"). A liner meeting technical specifications for contact with drinking water will be needed for the tank, because drinking water cannot come into direct contact with material that once was in contact with PCBs.

The tank is located adjacent to a streambed that provides a drainage ditch for the tank. The Workplan states that the streambed was dry during previous site visits, and that the stream likely flows during times of heavy rainfall. The drainage ditch is known to be contaminated with levels of PCBs exceeding the applicable Hawaii Department of Health Tier 1 environmental action level, per the investigation report dated August 22, 2018. Remediation of soils within the drainage ditch is outside the scope of the Workplan and will be addressed subsequently.

USEPA is approving KAI Hawaii's Workplan with conditions pursuant to 40 C.F.R. § 761.61(c) (i.e., risk-based disposal standards of TSCA). DOW shall implement the Workplan as modified by the conditions listed below.

**USEPA Conditions of Approval and Additional Comments:**

1. **Tank Drainage and PCB Disposal:** The following approach shall be used to drain the tank:
  - i. Test water at the effluent line sampling tap that draws water from the bottom region of the tank to confirm the PCB concentration is below the PCB drinking water maximum contaminant limit ("MCL") of 0.5 µg/L. Consult with USEPA and HDOH about PCB concentration and obtain concurrence to discharge water.
  - ii. If the PCB concentration in water is below the MCL, slowly discharge water from the bottom of the tank to minimize mixing of the water with the PCB-containing oily layer on the water surface. The water shall be drained at a rate slow enough to allow the discharged water to infiltrate into the ground surface before reaching approximately 200 feet downstream of the reservoir discharge pipe. The discharge process shall be observed at the 200-foot location to ensure the flow rate is slow enough. Drain continuously at a slow rate until the water level reaches a depth of approximately two (2) feet.
  - iii. DOW shall sample the oil sheen using an absorbent pad. A duplicate sample shall also be taken. The absorbent pad(s) shall be dried to remove water to the extent possible before analysis for PCBs using EPA Method 8082A with Soxhlet extraction. If the oil is determined to be at or greater than 50 ppm PCBs, then the oil, the absorbent pad(s), and the activated carbon filter units, required in step iv below, shall be disposed of at a hazardous waste landfill or a TSCA waste landfill, consistent with 40 C.F.R. § 761.61(a)(5)(i)(B)(2)(iii). If the oil is determined to be less than 50 ppm PCBs, then the oil and the absorbent pad(s) can be disposed of at a municipal landfill consistent with 40 C.F.R. § 761.61(a)(5)(i)(B)(2)(ii).
  - iv. Construct an activated carbon filter system and discharge the remaining water through the filter system.
  - v. Take a follow-up water sample following the carbon filter to confirm the PCB concentration is still below the MCL. If the PCB result is above the MCL, the active carbon shall be replaced or additional treatment such as bag filters shall be added after the carbon filter.
  - vi. Sample the activated carbon filter drum units for PCBs using EPA Method 8082A with Soxhlet extraction. If the PCB concentration of the filter media is determined to be less than 50 ppm, and if the concentration of the oil sheen (via the absorbent pad samples) is also determined to be less than 50 ppm, then the drum units can be disposed of at a municipal landfill consistent with 40 C.F.R. § 761.61(a)(5)(i)(B)(2)(ii). If the PCB concentration of the filter media or the oil is determined to be at or greater than 50 ppm, the activated carbon drum units shall be disposed of at a hazardous waste landfill or a TSCA waste landfill, consistent with 40 C.F.R. § 761.61(a)(5)(i)(B)(2)(iii).
2. **Drinking Water Sampling:** Following removal of the interior PCB coating, recoating of the interior of the tank, and refilling the tank with water, DOW shall sample water from the tank at the entry point to the distribution system for PCBs on a quarterly basis for at least three (3) quarters. If results are non-detect, then sampling can go to annual in perpetuity.
3. **Disposal of PCBs:** DOW shall dispose of all waste that it generates during the PCB cleanup in accordance with the TSCA PCB regulations and other applicable federal, state, and local regulations. In determining the disposal method for the waste, DOW must comply with the anti-dilution requirements in

40 C.F.R. § 761.1(b). All bulk PCB remediation waste (i.e., oil) must be disposed of in accordance with the requirements in 40 C.F.R. § 761.61(a)(5). DOW must select appropriate disposal facilities based on the in-situ PCB concentrations of the waste.


4. **PCB Cleanup Waste Disposal:** Cleanup waste (e.g., personal protective equipment, rags, gloves, booties) shall be disposed of in accordance with 40 C.F.R. § 761.61(a)(5)(v). Disposal of all waste shall be in accordance with all federal, state, and local regulations.
5. **Equipment Decontamination:** DOW shall decontaminate non-disposable sampling tools and equipment, as well as movable equipment used during cleanup and/or additional sampling in accordance with 40 C.F.R. § 761.79(c)(2). Decontamination residues must be disposed of at their original concentration in accordance with the requirements in 40 C.F.R. § 761.79(g). Recordkeeping of the decontamination events must be maintained in accordance with the requirements in 40 C.F.R. § 761.79(f)(2). These procedures must be implemented in a manner that is protective of human health and the environment consistent with the requirements in 40 C.F.R. § 761.79(e).
6. **PCB Cleanup Report:** DOW shall submit a PCB cleanup report to USEPA, to include all relevant data and justification demonstrating that the work completed is consistent with this approval. DOW must address at a minimum all the reporting requirements set forth at 40 C.F.R. § 761.61(a)(9) and 40 C.F.R. § 761.125(c)(5).
7. **Future Proposed Modifications to Cleanup Plan:** DOW shall request any changes to the approved cleanup plan via email to USEPA, and USEPA will provide any response to the request via email.

This approval does not relieve DOW from complying with all other applicable federal, state, and local regulations and permits. Departure from the conditions of the approval without prior written permission from USEPA may result in the commencement of proceedings to revoke this approval, and/or an enforcement action. Nothing in this approval bars USEPA from imposing penalties for violations of this approval or for violations of other applicable TSCA PCB requirements or for activities not covered under this approval.

This approval only applies to the Site. USEPA reserves the right to require additional characterization and/or cleanup of PCBs at the Site if new information during additional site characterization, cleanup verification, and/or during future post-cleanup activities (e.g. redevelopment or post-redevelopment) at the property shows that PCBs remain at the Site above the approved PCB cleanup level. In addition, USEPA may require cleanup of areas immediately adjacent to the site if those areas are found to be impacted by PCBs from the Site.

USEPA appreciates the opportunity to assist DOW with this PCB cleanup. If you have any questions regarding this approval, please contact Sara Ziff at (415) 972-3536 or [ziff.sara@epa.gov](mailto:ziff.sara@epa.gov). Thank you for your cooperation.

Sincerely,

  
Jeff Scott, Director  
Land Division

cc (electronic): Eric Fujikawa, DOW  
Eric Sadoyama, Hawaii Department of Health  
Myounghee Noh, Myounghee Noh & Associates

DEPARTMENT OF WATER  
COUNTY OF KAUAI

JOB NO. 17-10, WP2020 PROJECT NO. KW-07

# REHABILITATE PAUA VALLEY TANK NO. 1, 0.5 MG CONCRETE KEKAHA WATER SYSTEM

Kekaha, Kaua'i, Hawai'i

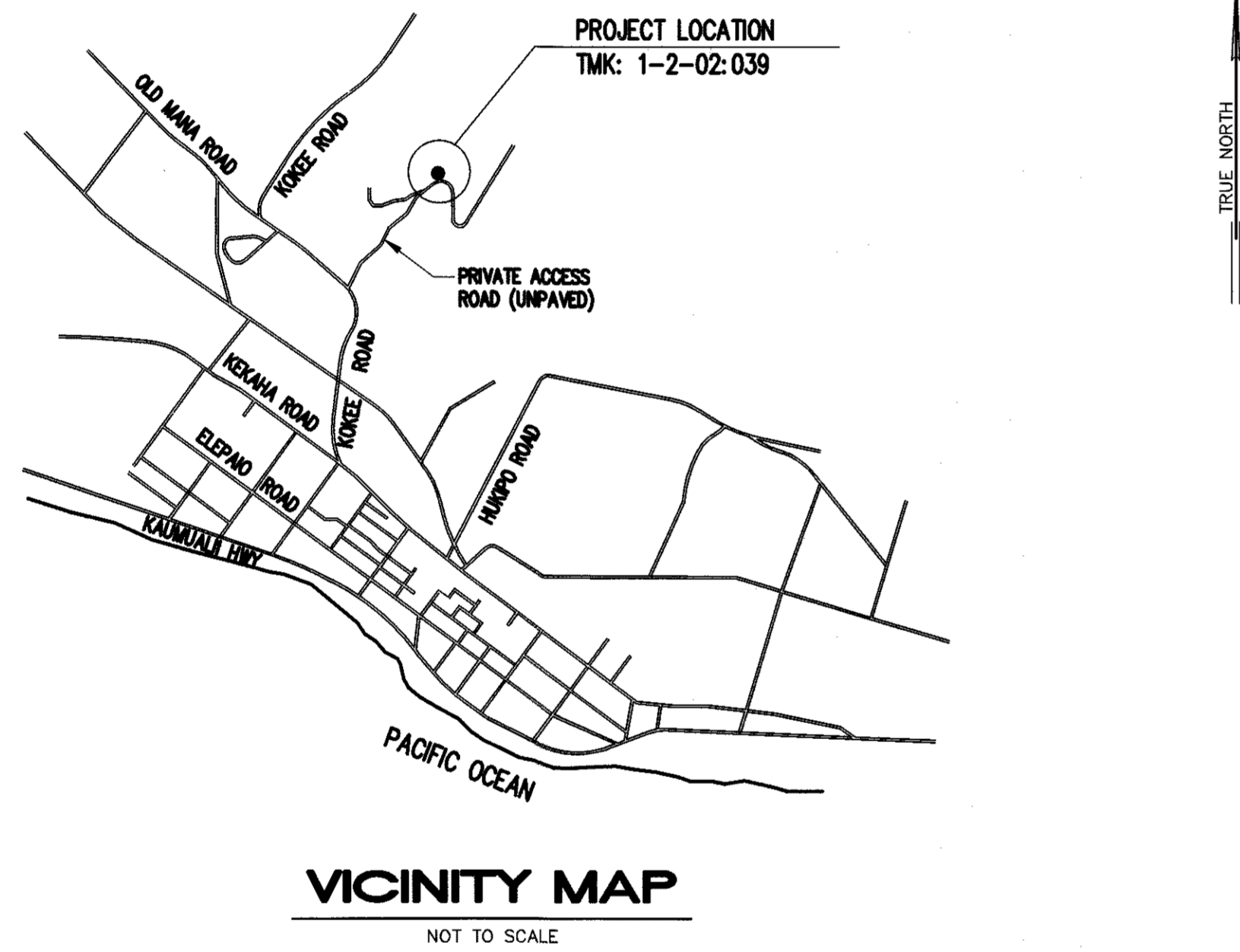
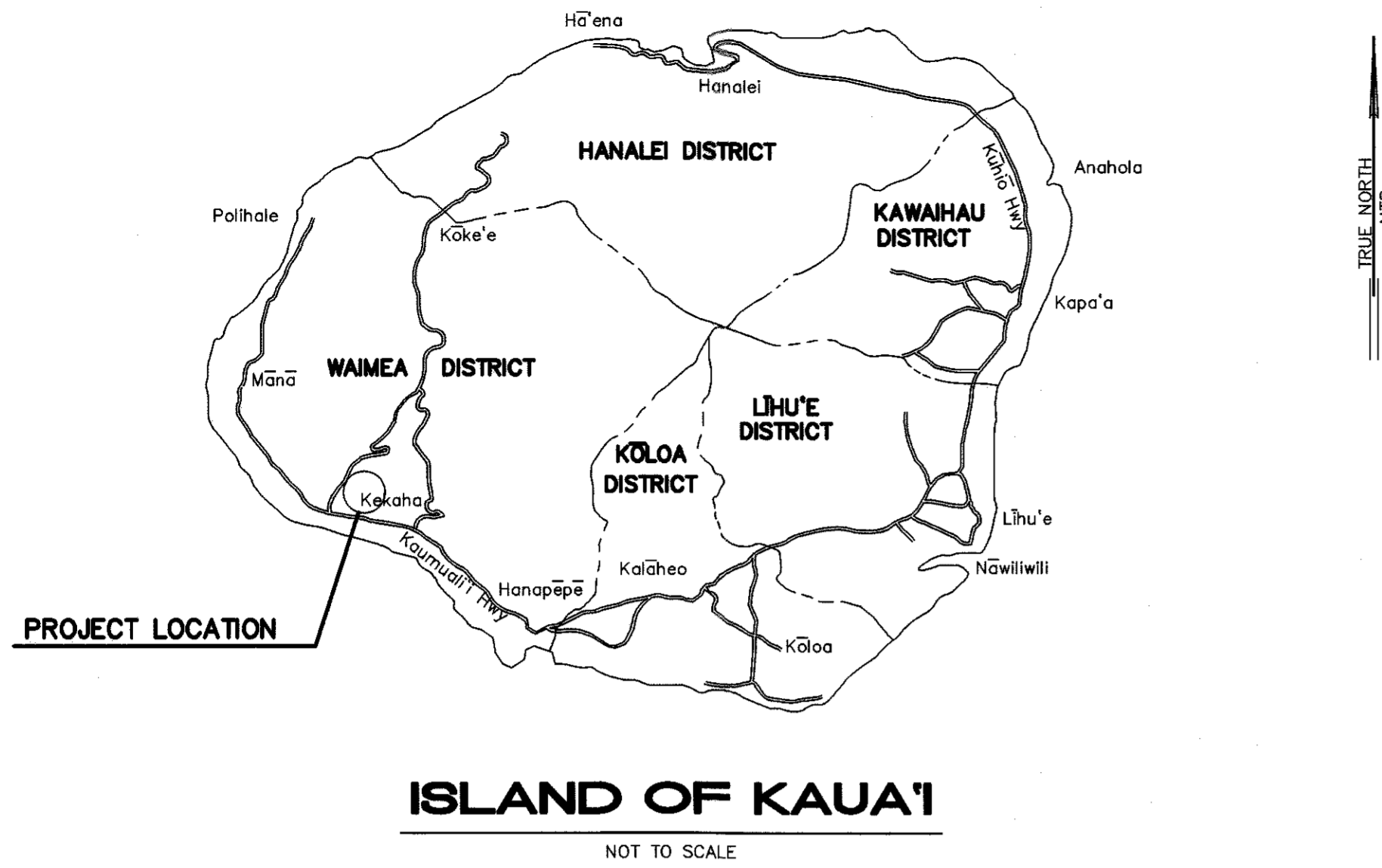
Tax Map Key: (4) 1-2-02: 039

PREPARED BY:

KAI HAWAII, INC.

50 SOUTH BERETANIA STREET #C-119C

HONOLULU, OAHU, HAWAII 96813



## INDEX TO DRAWINGS

SHEET NUMBER	DESCRIPTION
T-1	TITLE SHEET
T-2	WATER CONSTRUCTION, STRUCTURAL NOTES, ABBREVIATIONS
T-3	BMP NOTES, RESERVOIR WATER DISCHARGE NOTES
R-1	RESERVOIR REPAIR SITE PLAN
R-2	RESERVOIR CROSS SECTION AND DETAILS
R-3	RESERVOIR REPAIR DETAILS
R-4	LEVEL INDICATOR DETAILS
R-5	RESERVOIR WATER DISCHARGE SCHEMATIC PLAN AND DETAILS, INTERIOR LADDER DETAILS

APPROVED:

*[Signature]*  
MANAGER & CHIEF ENGINEER, DEPARTMENT OF WATER  
COUNTY OF KAUAI

1/18/19  
DATE

WATER CONSTRUCTION NOTES (REVISED 09-SEPT-2017):

- A. UNLESS OTHERWISE SPECIFIED, ALL MATERIALS AND CONSTRUCTION OF WATER FACILITIES AND APPURTENANCES SHALL BE IN ACCORDANCE WITH THE "WATER SYSTEM STANDARDS, 2002" AS ADOPTED BY THE DEPARTMENT OF WATER, COUNTY OF KAUAI, INCLUDING ALL SUBSEQUENT AMENDMENTS AND ADDITIONS.
  - B. ALL REQUIRED PROJECT SUBMITTALS (MATERIALS, SHOP DRAWINGS, CHLORINATION PLAN, ETC.) SHALL BE APPROVED BY THE DEPARTMENT CONSTRUCTION MANAGEMENT DIVISION BEFORE A PRE-CONSTRUCTION CONFERENCE CAN BE SCHEDULED. ONCE ALL PROJECT SUBMITTALS HAVE BEEN APPROVED BY DOW CONSTRUCTION ENGINEER, THE DOW CONSTRUCTION ENGINEER WILL NOTIFY THE CONTRACTOR THAT A PRECONSTRUCTION CONFERENCE CAN BE ARRANGED. THE CONTRACTOR SHALL ARRANGE A PRE-CONSTRUCTION CONFERENCE AT LEAST TEN (10) CALENDAR DAYS BEFORE CONSTRUCTION AND SHALL NOTIFY THE DEPARTMENT OF WATER AT LEAST THREE (3) WORKING DAYS PRIOR TO START OF CONSTRUCTION.
  - C. THE CONTRACTOR SHALL SUBMIT THE NAMES AND TELEPHONE NUMBERS OF ITS AUTHORIZED JOB SUPERINTENDENT AND AT LEAST THREE (3) ADDITIONAL PERSONS TO CONTACT IN CASE OF AN EMERGENCY DURING NON-WORKING HOURS.
  - D. THE CONTRACTOR SHALL NOTIFY THE DEPARTMENT OF WATER AT LEAST 24 HOURS PRIOR TO ANY TRENCHING, PIPE LAYING, BACKFILLING, TESTING OR DISINFECTION ACTIVITIES TO ENSURE THAT INSPECTION SERVICES WILL BE AVAILABLE.
  - E. ALL MATERIALS (PIPE, LUBRICANTS, PAINTS, SEALANTS, FORM OIL, CONCRETE ADMIXTURES, ETC.) IN DIRECT CONTACT WITH THE POTABLE WATER SHALL HAVE NATIONAL SANITATION FOUNDATION (NSF) CERTIFICATIONS. THE CONTRACTOR SHALL SUBMIT THESE CERTIFICATIONS TO THE DEPARTMENT OF WATER FOR REVIEW AND APPROVAL PRIOR TO ITS APPLICATION.
  - F. THE LOCATION OF EXISTING WATER MAINS AND APPURTENANCES SHOWN ON THE PLANS ARE APPROXIMATE ONLY. THE CONTRACTOR SHALL VERIFY THE EXACT LOCATIONS IN THE FIELD. EXCAVATION AROUND ANY EXISTING WATER MAIN SHALL BE DONE BY HAND.
  - G. THE CONTRACTOR SHALL PROVIDE UNOBSTRUCTED ACCESS TO EXISTING HYDRANTS, VALVES AND WATER METERS AT ALL TIMES.
  - H. THE CONTRACTOR SHALL SECURE ALL EXCAVATIONS IN ACCORDANCE WITH OSHA REGULATIONS.
  - I. THERE SHALL BE NO PHYSICAL CONNECTION BETWEEN A PUBLIC OR PRIVATE POTABLE WATER SYSTEM AND A NON-POTABLE WATER SYSTEM, SEWER, OR APPURTENANCE THERE TO WHICH COULD PERMIT THE PASSAGE OF ANY SEWAGE OR POLLUTED WATER INTO THE POTABLE WATER SUPPLY.
  - J. TRENCH EXCAVATION, BACKFILLING IN LIFTS, AND REPAVING SHALL CONFORM TO THE HAWAII STANDARD SPECIFICATIONS FOR ROAD AND BRIDGE CONSTRUCTION, 2005 AS AMENDED.
  - K. WARNING TAPE SHALL BE IN ACCORDANCE WITH DIVISION 200, SECTION 212.08 OF THE "WATER SYSTEM STANDARDS." THE WARNING TAPE SHALL BE FOUR MIL THICK, NON-METALLIC, ACID AND ALKALI RESISTANT POLYETHYLENE AND 6-INCHES WIDE WITH MINIMUM STRENGTH OF 1750 PSI LENGTHWISE AND 1500 PSI CROSSWISE. TAPE COLOR SHALL BE "SAFETY PRECAUTION BLUE" AND SHALL BEAR A CONTINUOUS PRINTED INSCRIPTION "CAUTION WATER LINE BURIED BELOW". INSCRIPTION SHALL BE 2-INCHES HIGH, BLACK TEXT.
  - L. ALL HYDRANTS SHALL RECEIVE A MINIMUM SSPC SP3 SURFACE PREPARATION AND COATED IN ACCORDANCE WITH DIVISION 200, SECTION 206.01 OF THE "WATER SYSTEM STANDARDS."
  - M. UNLESS OTHERWISE DIRECTED, PRIOR TO THE CONNECTION OF ANY PIPELINES AND/OR LATERALS TO THE EXISTING MAIN, THE PIPELINES/LATERALS INSTALLED SHALL BE CLEANED, PRESSURE TESTED, CHLORINATED, FLUSHED, AND SAMPLED IN ACCORDANCE WITH DIVISION 300, SECTIONS 302.27 TO 302.29 OF THE "WATER SYSTEM STANDARDS."
- WATER SAMPLES SHALL BE TESTED FOR TOTAL COLIFORMS BY A LABORATORY CERTIFIED BY THE STATE OF HAWAII TO PERFORM COLIFORM ANALYSIS. PRESENCE OF COLIFORM BACTERIA IS UNACCEPTABLE.
- IN ADDITION TO THE TEST FOR COLIFORMS, A SEPARATE TEST FOR HETEROTROPHIC PLATE COUNT (HPC) SHALL BE CONDUCTED. THE HPC COUNT SHALL BE LESS THAN 300 CFU/ML.
- PRIOR TO CHLORINATION, A WATER CHLORINATION AND SANITATION CONTRACTOR WITH A C-37D LICENSE SHALL SUBMIT A CHLORINATION PLAN WITH WATER SOURCE, INJECTION POINTS, SAMPLING POINTS AND PROCEDURE CLEARLY DEFINED FOR APPROVAL BY THE DOW.
- THE TESTED PIPELINES AND/OR LATERALS MUST BE CONNECTED TO THE EXISTING DOW SYSTEM WITHIN 14 CALENDAR DAYS OF PULLING THE FIRST DISINFECTION SAMPLE TESTED BY A CERTIFIED LABORATORY. THE DEPARTMENT OF WATER WILL REQUIRE THE CONTRACTOR TO REDO THE CLEANING, PRESSURE TESTING, AND/OR DISINFECTION OF THE PIPELINES AND/OR LATERALS AT THE CONTRACTOR'S EXPENSE IF THE CONNECTION IS NOT COMPLETED WITHIN THESE 14 CALENDAR DAYS.
- N. POLYURETHANE FOAM "PIGS" SHALL BE "PUSHED" THROUGH THE LENGTH OF THE INSTALLED PIPELINE USING PRESSURIZED WATER.
  - O. ALL CONNECTIONS SHALL BE SCHEDULED IN COORDINATION WITH THE DEPARTMENT OF WATER.
    - 1. AN ADVANCE DEPOSIT IS REQUIRED FOR OPERATING VALVES, FLUSHING LINES AND NOTIFYING CONSUMERS AFFECTED BY A WATER SHUTDOWN DURING CONNECTIONS. THE CONTRACTOR WILL BE CHARGED THE ACTUAL COST.
    - 2. THE CONTRACTOR SHALL PLACE THE DEPOSIT PRIOR TO SCHEDULING THE CONNECTION DATE.
    - 3. CONNECTIONS SHALL BE SCHEDULED ON TUESDAYS THROUGH THURSDAYS. NO CONNECTIONS SHALL BE SCHEDULED ON MONDAYS, FRIDAYS, WEEKENDS, AND HOLIDAYS, OR FROM DECEMBER 18 - JANUARY 8 OF EACH YEAR.
    - 4. ALL MATERIALS SHALL BE ON HAND AND APPROVED BY THE ENGINEER PRIOR TO SCHEDULING THE CONNECTION DATE.
    - 5. PUMPS USED TO DE-WATER THE CONNECTION AREA SHALL BE OPERATED IN THE PRESENCE OF THE ENGINEER PRIOR TO SCHEDULING THE CONNECTION DATE.
    - 6. ALL CONNECTIONS SHALL BE PERFORMED IN THE PRESENCE OF THE ENGINEER.

- P. IN ORDER TO PREVENT DAMAGE TO THE POLYETHYLENE ENCASUREMENT FROM EXCESSIVE HANDLING, THE POLYWRAP SHALL BE INSTALLED AROUND THE BARREL OF THE DUCTILE IRON PIPE AT ITS FINAL LOCATION ALONG THE TRENCHLINE. THE POLYETHYLENE ENCASED PIPE SHALL BE LIFTED USING A FABRIC TYPE SLING OR A SUITABLY PADDED CABLE OR CHAIN TO PREVENT DAMAGE TO THE POLYETHYLENE.
- Q. THE CONTRACTOR SHALL TAKE ALL NECESSARY COMPACTION TESTS WHILE THE WATERLINE TRENCH IS BEING BACKFILLED AND WHILE THE SUBBASE/ BASECOURSE IS BEING PLACED. IF THE TEST RESULTS INDICATE THAT ADDITIONAL COMPACTION IS REQUIRED, THE CORRECTIVE WORK SHALL BE COMPLETED BEFORE ANY ADDITIONAL TRENCH EXCAVATION OR PLACING OF SUBBASE/ BASECOURSE IS ALLOWED.
 

THE CONTRACTOR SHALL RETAIN THE SERVICES OF A REGISTERED GEOTECHNICAL ENGINEER FOR QUALITY CONTROL. THE COMPACTION TEST RESULTS SHALL BE CERTIFIED BY THE GEOTECHNICAL ENGINEER AND SUBMITTED TO THE DEPARTMENT OF WATER, STATE HIGHWAYS DIVISION (FOR WORK DONE WITHIN STATE R/W) AND THE DEPARTMENT OF PUBLIC WORKS (FOR WORK DONE WITHIN COUNTY R/W). THE GEOTECHNICAL ENGINEER SHALL CERTIFY THAT THE COMPACTION RESULTS MEET THE REQUIREMENTS OF THE CURRENT STANDARD SPECIFICATIONS FOR ROAD AND BRIDGE CONSTRUCTION.
- R. THE CONTRACTOR SHALL CONNECT ALL EXISTING CONSUMER PIPING TO THE NEW SERVICE LATERALS. THE DEPARTMENT OF WATER WILL TRANSFER THE EXISTING WATER METERS ONLY.
- S. ALL FITTINGS SHALL BE MECHANICAL JOINT (MJ) AT EACH END UNLESS OTHERWISE NOTED. "MEGALUG" RETAINER GLANDS SHALL BE USED WITH ALL MECHANICAL JOINT FITTINGS AND VALVES USED IN CONNECTING NEW WATER MAINS TO EXISTING WATER MAINS UNLESS OTHERWISE NOTED.
- T. ALL WATER VALVES THAT WILL BE ABANDONED IN PLACE SHALL BE PLACED IN THE "CLOSED" POSITION. REMOVE TOP SECTION OF VALVE BOX AND CONCRETE SETTLEMENT SLAB. FILL REMAINDER OF VALVE BOX WITH CONCRETE. PLACE BACKFILL AND REPAIR PAVEMENT SECTION TO APPLICABLE STATE OR COUNTY STANDARDS. BACKFILL TO FINISH GRADE IN ROAD SHOULDER AREA.
- U. THE CONTRACTOR SHALL OBTAIN ALL APPLICABLE DEPARTMENT OF HEALTH PERMITS PRIOR TO THE START OF CONSTRUCTION. PERMITS INCLUDE, BUT ARE NOT LIMITED TO, NATIONAL POLLUTION DISCHARGE ELIMINATION SYSTEM (NPDES) PERMITS FOR STORM WATER, HYDROSTATIC TEST, DEWATERING, AND FOR CONSTRUCTION ACTIVITIES, INCLUDING CLEARING, GRADING, AND EXCAVATION, THAT RESULT IN THE DISTURBANCE OF EQUAL TO OR GREATER THAN ONE (1) ACRE OF TOTAL LAND AREA.
 

THE CONTRACTOR SHALL BE RESPONSIBLE FOR THE PROPER DISPOSAL OF STORM WATER DISCHARGES AND EFFLUENT ASSOCIATED WITH CONSTRUCTION ACTIVITIES INCLUDING HYDROTESTING AND DISINFECTION OPERATIONS, TO SAFEGUARD PUBLIC HEALTH AND SAFETY IN ACCORDANCE WITH APPLICABLE DEPARTMENT OF HEALTH REQUIREMENTS. ALL PERMITS AND LICENSES FOR STORM WATER AND CONSTRUCTION WATER DISPOSAL, INCLUDING ALL APPLICATION, CHARGES, FEES, AND TAXES, ARE THE RESPONSIBILITY OF THE CONTRACTOR.
- V. THE CONTRACTOR IS RESPONSIBLE FOR DEWATERING TRENCH AS NECESSARY WHERE GROUNDWATER IS ENCOUNTERED. ALL ASSOCIATED COSTS FOR DEWATERING SHALL BE BORNE BY THE CONTRACTOR.
- W. THE USE OF KNOWN SEWER PUMP TRUCKS IS PROHIBITED FOR DOW PROJECTS FOR ANY USE, INCLUDING BUT NOT LIMITED TO DEWATERING AND TESTING OF NEW FACILITIES.
- X. THE CONTRACTOR SHALL VERIFY OUTSIDE DIAMETER OF ALL EXISTING ASBESTOS-CEMENT (AC) WATERLINES TO BE CONNECTED. CONTRACTOR SHALL VERIFY USE OF PROPER GASKETS PRIOR TO CONNECTION. AC PIPE AND GASKET INFORMATION SHALL BE SUBMITTED TO ENGINEER FOR APPROVAL.
- Y. ALL REMOVAL, DISPOSAL AND CONNECTION WORK THAT INVOLVES ASBESTOS PIPE/MATERIAL SHALL BE DONE IN THE PRESENCE OF OR BY A LICENSED ASBESTOS CONTRACTOR.
- Z. THE LICENSED ASBESTOS CONTRACTOR SHALL SUBMIT THEIR PLAN FOR ALL ASSOCIATED REMOVAL, DISPOSAL AND CONNECTION WORK FOR THE PROJECT TO DOW FOR REVIEW AND APPROVAL PRIOR TO CONDUCTING THE WORK.
- AA. ALL CONNECTIONS TO EXISTING AC PIPE SHALL BE AT THE NEAREST AC PIPE JOINT. AC PIPE SHALL BE REMOVED BY ENTIRE LENGTH(S) TO FACILITATE THE CONNECTION. CUTTING OF AC PIPE IS PROHIBITED.
- AB. THE CONTRACTOR SHALL FOLLOW ALL APPLICABLE OSHA, HIOSH AND FEDERAL REGULATIONS IN HANDLING AND DISPOSAL OF ASBESTOS-CEMENT PIPE. DISPOSAL OF THE PIPE SHALL BE AT AN APPROVED ASBESTOS MATERIAL DISPOSAL SITE.
- AC. ALL WATERWORKS BRASS FITTINGS SHALL BE IN COMPLIANCE WITH THE AMENDED SECTION 1417 OF SAFE DRINKING WATER ACT (SDWA) WHICH TAKES EFFECT ON JANUARY 4, 2014. THE AMENDMENT INCLUDES A CHANGE TO THE DEFINITION OF "LEAD-FREE" BY REDUCING LEAD CONTENT FROM 8% TO A WEIGHTED AVERAGE OF NOT MORE THAN 0.25% IN THE WETTED SURFACE MATERIAL. ALL WATERWORKS BRASS FITTINGS INSTALLED FOR POTABLE WATER SERVICE ON JANUARY 4, 2014 AND BEYOND SHALL CONFORM TO THE AMENDED DEFINITION OF "LEAD-FREE."
- AD. AS INDICATED IN SECTION 211 OF WATER SYSTEM STANDARDS - BRASS PRODUCTS, ALL BRASS FITTINGS SHALL CONFORM TO NSF STANDARD 61 AND SECTION 1417 OF THE SAFE DRINKING WATER ACT (SDWA), IN ADDITION, ALL BRASS FITTINGS SHALL CONFORM TO NSF STANDARD 372.
- AE. CONTRACTOR SHALL INSTALL WATER FACILITIES ONLY AFTER REACHING FINAL SUBGRADE OR HIGHER. THE DEPARTMENT OF WATER WILL NOT ALLOW INSTALLATION OF ANY WATER FACILITIES UNTIL THE FINAL SUBGRADE LAYER AT MINIMUM HAS BEEN ACHIEVED.
- AF. PRIOR TO INSTALLATION OF NEW WATER LINES AND /OR FACILITIES, THE CONTRACTOR SHALL HAVE ALL FACILITIES SURVEYED AND STAKED OUT BY A LICENSED SURVEYOR AND THE CONTRACTOR SHALL EXPOSE, VERIFY, AND BACKFILL ALL EXISTING UNDERGROUND UTILITIES AND STRUCTURES IN CLOSE PROXIMITY TO CROSSINGS AND CONNECTIONS PRIOR TO EXCAVATION OF PIPELINE TRENCH. CONTRACTOR SHALL PROVIDE THE LICENSED SURVEYOR CUT SHEET AND THE PROBING INFORMATION TO THE DOW CONSTRUCTION ENGINEER FOR REVIEW AND APPROVAL BEFORE MOVING FORWARD WITH INSTALLATION VIA THE SUBMITTAL REVIEW PROCESS.
- AG. THE DEPARTMENT SHALL BE PROVIDED TWENTY (20) WORKING DAYS FOR ALL SUBMITTAL REVIEWS FROM THE TIME OF SUBMISSION BY THE CONTRACTOR.

GENERAL:

- A. WORKMANSHIP AND MATERIALS SHALL CONFORM TO ACI 318-05 BUILDING CODE REQUIREMENTS FOR REINFORCED CONCRETE AND COMMENTARY. HOWEVER, WHERE REFERENCE IS MADE TO PERFORMANCE CONFORMING TO OTHER STANDARDS THE MORE STRINGENT SHALL APPLY.
- B. THE CONTRACTOR SHALL COMPARE ALL THE CONTRACT DOCUMENTS WITH EACH OTHER AND REPORT IN WRITING TO THE DOW ALL INCONSISTENCIES AND OMISSIONS.
- C. THE CONTRACTOR SHALL TAKE FIELD MEASUREMENTS AND VERIFY FIELD CONDITIONS AND SHALL COMPARE SUCH FIELD MEASUREMENTS AND CONDITIONS WITH THE DRAWINGS BEFORE COMMENCING WORK. REPORT IN WRITING TO OFFICER-IN-CHARGE ALL INCONSISTENCIES AND OMISSIONS.
- D. THE CONTRACTOR SHALL BE RESPONSIBLE FOR COORDINATING THE WORK OF ALL TRADES.
- E. THE CONTRACTOR SHALL BE RESPONSIBLE FOR MEANS AND METHODS OF CONSTRUCTION, WORKMANSHIP AND JOB SAFETY.
- F. THE CONTRACTOR SHALL PROVIDE TEMPORARY SHORING AND BRACING AS REQUIRED FOR STABILITY OF STRUCTURAL MEMBERS AND SYSTEMS.
- G. CONSTRUCTION LOADING SHALL NOT EXCEED DESIGN LIVE LOAD UNLESS SPECIAL SHORING IS PROVIDED. PERMITTED CONSTRUCTION LOADS SHALL BE PROPERLY REDUCED IN AREAS WHERE THE STRUCTURE HAS NOT ATTAINED FULL DESIGN STRENGTH.
- H. THE CONTRACTOR SHALL BE RESPONSIBLE FOR PROTECTION OF UNDERGROUND STRUCTURES AND UTILITIES DURING THE CONSTRUCTION PERIOD. ANY DAMAGED OR DETERIORATED PROPERTY SHALL BE RESTORED TO THE CONDITION PRIOR TO THE BEGINNING OF WORK OR BETTER AT NO COST TO BWS.
- I. DETAILS NOTED AS TYPICAL ON THE STRUCTURAL DRAWINGS SHALL APPLY IN ALL CONDITIONS UNLESS SPECIFICALLY SHOWN OR NOTED OTHERWISE.

CONCRETE REPAIR:

- A. REMOVE SPALLED, DELAMINATED, OR DETERIORATED CONCRETE TO SOUND SUBSTRATE AND BEYOND THE EXTENT OF CORRODED REINFORCING.
- B. FULLY EXPOSE AND REMOVE CORROSION FROM REINFORCING STEEL AND COAT WITH BONDING AGENT.
- C. PROPERLY CLEAN AND PREPARE CONCRETE SUBSTRATE. REPAIR CONCRETE PER MANUFACTURER'S SPECIFICATIONS.
- D. SCRUB REPAIR MORTAR INTO REPAIR SURFACE PRIOR TO INSTALLATION OF REPAIR-SEE MANUFACTURER'S RECOMMENDATIONS.
- E. APPLY REPAIR MORTAR INTO REPAIR AREA BY FORCING MATERIAL AGAINST EDGE OR REPAIR AREA WORKING TOWARD CENTER.
- F. FINISH AND CURE AS DESCRIBED IN SPECIFICATION.

SURFACE PREPARATION NOTES FOR SPALL REPAIRS:

- A. DETERIORATED CONCRETE SHALL BE REMOVED DOWN TO SOUND SUBSTRATE, OR TO THE SPECIFIED DEPTH AS NOTED IN THE SPALL REPAIR DETAILS. SAWCUT ALL EDGES MINIMUM OF 1/2" DEEP, NO FEATHERING OF PATCHING MATERIAL IS ALLOWED. AVOID CUTTING ANY REINFORCING STEEL WHEN SAWCUTTING. THE EXPOSED CONCRETE SHALL BE ROUGHENED TO A 1/8" AMPLITUDE AND SHALL BE CLEANED AND FREE OF LAITANCE, DUST AND OTHER BOND INHIBITING MATERIALS.
- B. ALL REINFORCING STEEL DAMAGED DUE TO THE CONTRACTOR'S OPERATIONS SHALL BE REPAIRED BY THE CONTRACTOR AT HIS/HER EXPENSE AND TO THE SATISFACTION OF THE ENGINEER.
- C. ALL LOOSE, SOFT, HONEY-COMBED, DISINTEGRATED CONCRETE, PLUS 3/4 INCH MINIMUM DEPTH OF CONCRETE BEYOND THE BACK FACE OF THE REBAR WITHIN THE SPALL AREA SHALL BE REMOVED.
- D. AFTER COMPLETION OF THE REMOVAL OPERATION, THE ENGINEER WILL RESOUND THE AREAS TO ENSURE THAT ONLY SOUND CONCRETE REMAINS.
- E. CLEANING SHALL PRECEDE APPLICATION OF THE PATCHING MATERIAL BY NOT MORE THAN 24 HOURS.

BONDING AGENT:

- A. AFTER THE CONCRETE SURFACES HAVE BEEN PREPARED AND CLEANED, AND IMMEDIATELY BEFORE PLACING THE CONCRETE PATCHING, A COAT OF BONDING AGENT SHALL BE APPLIED. THE SURFACE SHALL RECEIVE A THOROUGH AND EVEN COATING, AND EXCESS BONDING AGENT SHALL NOT BE PERMITTED TO COLLECT IN POCKETS. THE RATE OF PROGRESS IN APPLYING THE BONDING AGENT SHALL BE LIMITED SO THAT IT DOES NOT BECOME DRY BEFORE IT IS COVERED WITH THE CONCRETE PATCHING. SHOULD THE SURFACE OF THE BONDING AGENT DRY, THE DRIED BONDING AGENT SHALL BE COMPLETELY REMOVED AND FRESH BONDING AGENT APPLIED. REMOVAL SHALL BE BY SANDBLASTING OR BY ANOTHER PROCEDURE APPROVED BY THE ENGINEER. THE REMOVAL OF BONDING AGENT SHALL BE AT THE EXPENSE OF THE CONTRACTOR.
- B. THE BONDING AGENT SHALL PROVIDE CORROSION PROTECTION TO THE REINFORCING STEEL AND SHALL ACT AS A BONDING AGENT FOR THE FRESH PATCHING MORTAR. ALL EXPOSED REINFORCING STEEL SHALL RECEIVE TWO (2) COATS AT 20 MILS EACH, TOTAL OF 40 MILS. THE CONCRETE SURFACE SHALL RECEIVE ONE (1) COAT AT 20 MILS. FOLLOW MANUFACTURER'S SPECIFICATIONS FOR RECOMMENDED TIME BETWEEN APPLICATION OF BONDING AGENT AND PATCHING MORTAR. THE MINIMUM BOND STRENGTH PROVIDED BY THE BONDING AGENT SHALL BE 2,000 PSI AFTER 14 DAYS (ASTM C-882).

POLYMER MODIFIED PATCHING MORTAR:

- A. PATCHING MORTAR SHALL BE A POLYMER MODIFIED MORTAR, HAVE HIGH ABRASION RESISTANCE AND SHALL BE SUITABLE FOR HORIZONTAL, VERTICAL AND OVERHEAD SURFACES. THE MINIMUM BOND STRENGTH PROVIDED BY THE PATCHING MORTAR SHALL BE 2,000 PSI AFTER 28 DAYS (ASTM C-882). REFER TO MANUFACTURER'S SPECIFICATIONS FOR PREPARATION AND APPLICATION GUIDANCE.
- B. CURING: AS PER ACI RECOMMENDATIONS FOR PORTLAND CEMENT CONCRETE, CURING IS REQUIRED. FOLLOW THE MANUFACTURER'S RECOMMENDATION FOR CURING MATERIAL AND PROCEDURE.
- C. MULTIPLE LIFTS: FOLLOW THE MANUFACTURER'S LIMITATIONS FOR MAXIMUM THICKNESS FOR APPLICATION OF PATCHING MORTAR. IF THE REQUIRED THICKNESS OF A REPAIR IS GREATER THAN THE SINGLE APPLICATION LIMIT, MULTIPLE LIFTS ARE REQUIRED. LARGE, UNCONFINED OR OVERHEAD REPAIRS MAY ALSO REQUIRE MULTIPLE LIFTS. IF SUCCESSIVE LIFTS ARE TO BE APPLIED, ROUGHEN THE SURFACE OF THE PREVIOUS LIFT AND APPLY SUBSEQUENT LIFTS WITHIN THE TIME PERIOD, BOTH AS RECOMMENDED BY THE MANUFACTURER.

ABBREVIATIONS:

AC	ASPHALT CONCRETE
BLDG.	BUILDING
BLK.	BLOCK
CLR.	CLEAR
CONC.	CONCRETE
CONT.	CONTINUOUS
CRM	CEMENT ROCK MASONRY
DIAM.	DIAMETER
DOW	DEPARTMENT OF WATER
ELEC	ELECTRICAL
ELEV	ELEVATION
EMBED	EMBEDMENT
EXIST., (E)	EXISTING
GALV.	GALVANIZED
HDG	HOT DIP GALVANIZED
HORIZ	HORIZONTAL
I.D.	INSIDE DIAMETER
L	LENGTH
LBP	LEAD-BASED PAINT
LCP	LEAD-CONTAINING PAINT
LLH	LONG LEG HORIZONTAL
MANUF	MANUFACTURER
MAX	MAXIMUM
MG	MILLION GALLON
MH	MANHOLE
MIN.	MINIMUM
O.C.	ON CENTER
OD	OUTSIDE DIAMETER
PCB	POLYCHLORINATED BIPHENYLS
PVC	POLYVINYL CHLORIDE
SECT	SECTION
SIM	SIMILAR
SQ.	SQUARE
SPEC	SPECIFICATION
S.S.	STAINLESS STEEL
TEL	TELECOMMUNICATIONS
THK.	THICK
Typ.	TYPICAL
W/	WITH
&	AND
#	NUMBER
℄	CENTER LINE
∅	DIAMETER
≥	GREATER OR EQUAL TO
%	PERCENT

REVISION	DATE	DESCRIPTION	BY	APPROVED
<b>REHABILITATE PAUA VALLEY TANK #1</b>				
WATER CONSTRUCTION AND STRUCTURAL NOTES, ABBREVIATIONS				
				APPROVED: 1/18/19 DATE MANAGER & CHIEF ENGINEER, DEPT. OF WATER, COUNTY OF KAUAI
This work was prepared by me or under my supervision and construction to this project will be under my observation.				
KAI HAWAII, INC. HONOLULU, OAHU, HAWAII, 96813				
DESIGNED BY: DY		DRAWN BY: CAD		DATE: 1-09-19
DRAWING NO. T-2				SHEET 2 OF 8 SHEETS

P:\4301-4350\4339 DWS - Rehabilitate Paua Valley Tank #1 - 0.5 MG Concrete, Kekaha\004 - Drawings\Structural\AutoCAD - Format\2019-01-09\_4339 DWS Paua\4339\_T-2.dwg, 1/10/2019 3:43:19 PM, dylakomizo

**RESERVOIR WATER (CONTAINING PCB) DISCHARGE NOTES:**

- A. THE CONTRACTOR SHALL REVIEW AND FOLLOW THE APPROVED WORKPLAN IN THE USEPA CONDITIONAL APPROVAL OF PCB CLEANUP PLAN UNDER THE TOXIC SUBSTANCES CONTROL ACT (TSCA), 40 CFR 761.61(c), FOR PAUA VALLEY TANK #1, KEKAHA, KAUAI, HAWAII, DATED 10/16/18, FOR DISCHARGING THE PCB-CONTAINING STORAGE WATER FROM THE EXISTING RESERVOIR AND DISPOSING OF PCB WASTE.
- B. DISCHARGE LOCATION AND SCHEDULE:
  - 1. THE WATER IN THE RESERVOIR SHALL BE DISCHARGED INTO THE PAUA DRAINAGE DITCH AT A RATE TO ALLOW THE DISCHARGED WATER TO INFILTRATE INTO THE GROUND SURFACE BEFORE REACHING APPROXIMATELY 200 FEET DOWNSTREAM OF THE RESERVOIR DISCHARGE PIPE.
  - 2. THE DISCHARGE RATE WILL BE APPROXIMATELY 14,000 GALLONS/DAY FOR 25 DAYS.
- C. ACTIVATED CARBON FILTER SYSTEM:
  - 1. AFTER DETERMINING THAT THE PCB CONCENTRATION IN THE WATER SAMPLE TAKEN FROM THE EFFLUENT LINE SAMPLING TAP IS BELOW THE ALLOWABLE UPPER LIMIT (0.5 µg/L), SLOWLY DISCHARGE WATER FROM THE RESERVOIR CLEANOUT DRAIN LINE TO MINIMIZE THE MIXING OF THE WATER WITH THE PCB-CONTAINING "OILY" LAYER ON THE WATER SURFACE. DRAIN CONTINUOUSLY AT A SLOW RATE UNTIL THE WATER LEVEL REACHES A DEPTH OF APPROXIMATELY 2 FEET.
  - 2. TO DRAIN THE REMAINING WATER IN THE RESERVOIR, CONSTRUCT THE ACTIVATED CARBON FILTER SYSTEM BY CONNECTION A PIPE EXTENSION AT THE END OF THE DRAINAGE DISCHARGE PIPE FROM THE RESERVOIR BY REMOVING THE EXISTING FLAP GATE VALVE AND CONNECT TWO LIQUID PHASE ABSORBER UNIT DRUMS CONTAINING VIRGIN ACTIVATED CARBON 8 X 12 MESH DESIGNED TO ABSORB PCB. THE DISCHARGE RATE FOR TWO UNITS CONNECTED IN PARALLEL IS 10 GALLONS PER MINUTE. THIS ABSORBER UNIT DRUM IS A MANUFACTURED ASSEMBLY AND CAN BE PURCHASED FROM THE MANUFACTURERS LISTED IN THE SPECIAL PROVISIONS.
  - 3. RELEASE AS MUCH WATER AS WILL DRAIN BY GRAVITY. TO CLEAN UP THE REMAINING RESIDUE, REFER TO THE SPECIAL PROVISIONS, SECTION SP-5 REMOVAL AND DISPOSAL OF BULK MATERIAL CONTAINING PCB.
- D. SAMPLE COLLECTION AND LABORATORY ANALYSIS:
  - 1. COLLECTED SAMPLES SHALL BE STORED BETWEEN 0 - 4 °CELSIUS UNTIL THE SAMPLES ARE DELIVERED TO THE LABORATORY. THE SAMPLES SHALL BE STORED AT THE REQUIRED TEMPERATURE IMMEDIATELY AFTER COLLECTION TO PRESERVE THE CONDITION AT THE TIME OF COLLECTION. THE SAMPLER SHALL COORDINATE FURTHER WITH AN ANALYTICAL LABORATORY TO CONFIRM THE TESTING METHOD, SAMPLE AMOUNT, AND SAMPLE PRESERVATION REQUIREMENTS.
- E. SITE RESTORATION
  - 1. AFTER DISCHARGE IS COMPLETE, RESTORE PIPING AND GRADE TO PREVIOUS CONDITION OR BETTER, ACCEPTABLE TO DOW.
  - 2. BACKFILL AND COMPACT SOIL AND ROCKS TO MINIMIZE FUTURE EROSION IN STREAM BED.

**BEST MANAGEMENT PRACTICES (BMP) NOTES:**

- A. GENERAL
  - 1. THE CONTRACTOR IS REMINDED OF THE REQUIREMENTS OF SECTION 209-WATER POLLUTION AND EROSION CONTROL AND SECTION 620-DUST CONTROL, IN THE "HAWAII STANDARD SPECIFICATIONS FOR ROAD AND BRIDGE CONSTRUCTION 2005," AS AMENDED. SECTION 209 DESCRIBES BUT IS NOT LIMITED TO: SUBMITTAL REQUIREMENTS; SCHEDULING OF A WATER POLLUTION AND EROSION CONTROL CONFERENCE WITH THE ENGINEER; CONSTRUCTION REQUIREMENTS; METHOD OF MEASUREMENT; AND BASIS OF PAYMENT. NO WORK SHALL COMMENCE WITHOUT A BMP PLAN APPROVED BY THE DEPARTMENT OF HEALTH.
  - 2. THE CONTRACTOR SHALL FOLLOW THE GUIDELINES IN THE "INTERIM BEST MANAGEMENT PRACTICES MANUAL FOR CONSTRUCTION SITES FOR COUNTY OF KAUAI" APRIL 2004 IN DEVELOPING, INSTALLING AND MAINTAINING THE BEST MANAGEMENT PRACTICES (BMPs) FOR THE PROJECT. THE CONTRACTOR MAY SUBMIT ALTERNATE METHODS TO THE ENGINEER FOR ACCEPTANCE.
  - 3. THE CONTRACTOR SHALL KEEP A COPY OF THE APPROVED BMP PLAN, NOI, ETC. ON THE PROJECT SITE. THE BMP PLAN SHALL BE UPDATED TO REFLECT ANY CHANGES MADE DURING THE COURSE OF CONSTRUCTION FOR THE DURATION OF THE PROJECT.
  - 4. THE COUNTY ENGINEER MAY ASSESS LIQUIDATED DAMAGES OF UP TO \$27,500 FOR NON-COMPLIANCE OF EACH BMP REQUIREMENT AND EACH REQUIREMENT STATED IN SECTION 209, FOR EVERY DAY OF NON-COMPLIANCE. THERE IS NO MAXIMUM LIMIT ON THE AMOUNT ASSESSED PER DAY.
  - 5. THE COUNTY ENGINEER MAY DEDUCT THE COST FROM THE PROGRESS PAYMENT FOR ALL CITATIONS RECEIVED BY THE DEPARTMENT FOR NON-COMPLIANCE, OR THE CONTRACTOR / OWNER SHALL REIMBURSE THE STATE, AND / OR COUNTY FOR THE FULL AMOUNT OF THE OUTSTANDING COST INCURRED BY THE STATE AND / OR COUNTY.
- B. TEMPORARY EROSION CONTROL MEASURES:
  - 1. PRIOR TO CLEARING LAND FOR GRADING, ALL TEMPORARY EROSIONS CONTROL MEASURES, SUCH AS SILT FENCES AND CONSTRUCTION ACCESS SHALL BE INSTALLED.
  - 2. ENTRY/EXIST DRIVEWAYS SHALL BE ESTABLISHED PRIOR TO CLEARING OPERATIONS. DRIVEWAYS SHALL BE A MINIMUM OF 12 FEET WIDE AND 50 FEET LONG, 6" THICK OF 2-3 INCH WASHED STONES OR CRUSHED ROCK.
  - 3. OPENING AND CLEARING OF LAND FOR GRADING SHALL BE PERFORMED INCREMENTALLY TO MINIMIZE EROSION POTENTIAL.
  - 4. AREAS NOT WITHIN THE LIMITS OF CLEARING AND GRUBBING SHALL REMAIN VEGETATED DURING GRADING OPERATIONS.
  - 5. SILT WHICH HAS ACCUMULATED ON SILT FENCE SHALL BE REMOVED AND DISPOSED OF ON A BI-WEEKLY BASIS.
  - 6. STOCKPILES SHALL NOT BE LOCATED IN DRAINAGE WAYS OR OTHER AREAS ON CONCENTRATED FLOWS, SEDIMENT TRAPPING DEVICES SUCH AS FENCES, TRAPS, BASINS, OR BARRIERS SHALL BE USED AROUND THE BASE OF ALL STOCKPILES.
  - 7. DUST CONTROL SHALL BE APPLIED TO REDUCE EMISSIONS. THE CONTRACTOR, AT HIS OWN EXPENSE, SHALL KEEP THE PROJECT AREA AND SURROUNDING AREA FREE FROM DUST NUISANCE. THE WORK SHALL BE IN CONFORMANCE WITH THE AIR POLLUTION CONTROL STANDARDS CONTAINED IN HAWAII ADMINISTRATIVE RULES: CHAPTER 11-60, "AIR POLLUTION CONTROL". CONTRACTOR SHOULD KEEP THE OPEN SITE WATERED DURING CONSTRUCTION HOURS.
  - 8. SEDIMENT FENCES OR BARRIERS SHALL BE USED DOWN SLOPE OF ALL DISTURBED AREAS OR STOCKPILE AREAS.

- 9. ALL DISTURBED AREAS SHALL BE PERMANENTLY STABILIZED PRIOR TO REMOVING EROSION AND SEDIMENT MEASURES. ALL TEMPORARY EROSION AND SEDIMENT CONTROL MEASURE SHALL BE REMOVED WITHIN 30 DAYS AFTER FINAL SITE STABILIZATION OR AFTER THE TEMPORARY MEASURE ARE NO LONGER NEEDED. TRAPPED SEDIMENT AND AREAS OF DISTURBED SOIL WHICH RESULT FROM THE REMOVAL OF THE TEMPORARY MEASURE SHALL BE IMMEDIATELY AND PERMANENTLY STABILIZED.

**C. EROSION AND SEDIMENT CONTROL INSPECTION AND MAINTENANCE PRACTICES:**

- 1. THE CONTRACTOR SHALL INSPECT THE EROSION AND SEDIMENT CONTROL MEASURES AT LEAST TWICE A WEEK OR AFTER A 0.5 INCHES OF RAINFALL EVENT.
- 2. THE CONTRACTOR SHALL MAINTAIN THE EROSION AND SEDIMENT CONTROL MEASURES ACCORDING TO THE CONTRACT. IF A REPAIR IS NECESSARY, THE CONTRACTOR SHALL INITIATE THE REPAIRS WITHIN TWENTY-FOUR (24) HOURS AFTER THE INSPECTION SUCH AS:
  - a. WHEN SEDIMENT BUILDUP REACHES ONE-THIRD (1/3) THE HEIGHT OF THE SILT FENCE, THE CONTRACTOR SHALL REMOVE AND DISPOSE OF THE SEDIMENT BUILDUP FROM THE SILT FENCE.
  - b. WHEN TEARS ARE FOUND ON THE SILT FENCE, THE CONTRACTOR SHALL REPLACE THE FABRIC.
  - c. THE CONTRACTOR SHALL CHECK TO SEE IF THE FABRIC IS SECURELY ATTACHED TO THE FENCE POSTS AND TO SEE THAT THE FENCE POSTS ARE FIRMLY IN THE GROUND.
- 3. THE CONTRACTOR SHALL HAVE ITS PERSONNEL MAKE A MAINTENANCE INSPECTION REPORT PROMPTLY AFTER EACH INSPECTION. THE CONTRACTOR SHALL SELECT A MINIMUM OF THREE (3) PERSONNEL WHO WILL BE RESPONSIBLE FOR INSPECTION, MAINTENANCE, REPAIR ACTIVITIES, AND FILLING OUT THE INSPECTION AND MAINTENANCE REPORT. PERSONNEL SELECTED FOR THE INSPECTION AND MAINTENANCE RESPONSIBILITIES WILL RECEIVE TRAINING FROM THE CONTRACTOR. THE CONTRACTOR SHALL TRAIN THESE PERSONNEL IN THE INSPECTION AND MAINTENANCE PRACTICES NECESSARY FOR KEEPING THE EROSION AND SEDIMENT USED ON-SITE ACCORDING TO THE CONTRACT.

**D. WASTE DISPOSAL**

- 1. **WASTE MATERIALS:** ALL WASTE MATERIALS SHALL BE COLLECTED AND STORED IN A SECURELY LIDDED METAL DUMPSTER THAT DOES NOT LEAK. THE DUMPSTER SHALL MEET ALL LOCAL AND STATE SOLID WASTE MANAGEMENT REGULATIONS. ALL TRASH AND CONSTRUCTION DEBRIS FROM THE SITE SHALL BE DEPOSITED IN THE DUMPSTER. THE DUMPSTER SHALL BE EMPTIED A MINIMUM OF TWICE (2) PER WEEK OR AS OFTEN AS IS DEEMED NECESSARY. NO CONSTRUCTION WASTE MATERIALS SHALL BE BURIED ONSITE. THE CONTRACTOR'S SUPERVISORY PERSONNEL SHALL BE INSTRUCTED REGARDING THE CORRECT PROCEDURE FOR WASTE DISPOSAL. NOTICES STATING THESE PRACTICES SHALL BE POSTED IN THE OFFICE TRAILER AND THE CONTRACTOR SHALL BE RESPONSIBLE FOR SEEING THAT THESE PROCEDURES ARE FOLLOWED.
- 2. **HAZARDOUS WASTE:** ALL HAZARDOUS WASTE MATERIALS SHALL BE DISPOSED OF IN THE MANNER SPECIFIED BY LOCAL OR STATE REGULATIONS OR BY THE MANUFACTURER. THE CONTRACTOR'S SITE PERSONNEL SHALL BE INSTRUCTED IN THESE PRACTICES AND SHALL BE RESPONSIBLE FOR SEEING THAT THESE PRACTICES ARE FOLLOWED.
- 3. **SANITARY WASTE:** ALL SANITARY WASTE SHALL BE COLLECTED FROM THE PORTABLE UNITS A MINIMUM OF ONCE PER WEEK, OR AS REQUIRED.

**E. GOOD HOUSEKEEPING BEST MANAGEMENT PRACTICES**

- 1. **MATERIALS POLLUTION PREVENTION PLAN**
  - a. APPLICABLE MATERIALS OR SUBSTANCES LISTED BELOW ARE EXPECTED TO BE PRESENT ONSITE DURING CONSTRUCTION. OTHER MATERIALS AND SUBSTANCES NOT LISTED BELOW SHALL BE ADDED TO THE INVENTORY OF THE CONSTRUCTION CONTRACTOR'S SITE-SPECIFIC BMP PLAN.
 

CONCRETE	FERTILIZERS
DETERGENTS	PETROLEUM BASED PRODUCTS
PAINTS (ENAMEL & LATEX)	CLEANING SOLVENTS
WOOD	
  - b. MATERIAL MANAGEMENT PRACTICES SHALL BE USED TO REDUCE THE RISK OF SPILLS OR OTHER ACCIDENTAL EXPOSURE OF MATERIALS AND SUBSTANCES TO STORM WATER RUNOFF. AN EFFORT SHALL BE MADE TO STORE ONLY ENOUGH PRODUCTS AS IS REQUIRED TO DO THE JOB.
  - c. ALL MATERIALS STORED ONSITE SHALL BE STORED IN A NEAT, ORDERLY MANNER IN THEIR APPROPRIATE CONTAINERS AND IF POSSIBLE UNDER A ROOF OR OTHER ENCLOSURE.
  - d. PRODUCTS SHALL BE KEPT IN THEIR ORIGINAL CONTAINERS WITH THE ORIGINAL MANUFACTURER'S LABEL.
  - e. SUBSTANCES SHALL NOT BE MIXED WITH ONE ANOTHER UNLESS RECOMMENDED BY THE MANUFACTURER.
  - f. A PRODUCT SHALL BE USED UP COMPLETELY BEFORE DISPOSING OF THE CONTAINER.
  - g. MANUFACTURER'S RECOMMENDATIONS FOR PROPER USE AND DISPOSAL SHALL BE FOLLOWED.
  - h. THE CONTRACTOR SHALL CONDUCT A DAILY INSPECTION TO ENSURE PROPER USE AND DISPOSAL OF MATERIALS ONSITE.
- 2. **HAZARDOUS MATERIAL POLLUTION PREVENTION PLAN**
  - a. PRODUCTS SHALL BE KEPT IN ORIGINAL CONTAINERS UNLESS THEY ARE NOT RESEALABLE.
  - b. ORIGINAL LABELS AND MATERIAL SAFETY DATA SHEETS (MSDS) SHALL BE RETAINED AND MADE AVAILABLE TO THE ENGINEER UPON REQUEST.
  - c. SURPLUS PRODUCTS SHALL BE DISPOSED OF ACCORDING TO MANUFACTURER'S INSTRUCTIONS OR LOCAL AND STATE RECOMMENDED REGULATIONS.
- 3. **ON-SITE AND OFF-SITE PRODUCTS SPECIFIC PRACTICES PLANS**
  - a. **PETROLEUM BASED PRODUCTS:** MONITOR ALL ON-SITE VEHICLES FOR LEAKS AND PERFORM REGULAR PREVENTIVE MAINTENANCE TO REDUCE THE CHANCE OF LEAKAGE. STORE PETROLEUM PRODUCTS IN TIGHTLY SEALED CONTAINERS WHICH ARE CLEARLY LABELED. APPLY ASPHALT SUBSTANCES USED ON-SITE ACCORDING TO THE MANUFACTURER'S RECOMMENDATION.
  - b. **FERTILIZERS:** APPLY FERTILIZERS USED ONLY IN THE MINIMUM AMOUNTS RECOMMENDED BY

- THE MANUFACTURER. ONCE APPLIED, WORK FERTILIZER INTO THE SOIL TO LIMIT EXPOSURE TO STORM WATER. STORAGE SHALL BE IN A COVERED SHED. TRANSFER THE CONTENTS OF ANY PARTIALLY USED BAGS OF FERTILIZER TO A SEALABLE PLASTIC BIN TO AVOID SPILLS.
- c. **PAINTS:** SEAL AND STORE ALL CONTAINERS WHEN NOT REQUIRED FOR USE. DO NOT DISCHARGE EXCESS PAINT TO THE HIGHWAY DRAINAGE SYSTEM. DISPOSE PROPERLY ACCORDING TO MANUFACTURER'S INSTRUCTIONS OR STATE AND LOCAL REGULATIONS.
- d. **CONCRETE TRUCKS:** WASH OUT OR DISCHARGE CONCRETE TRUCK DRUM WASH WATER ONLY AT A DESIGNATED SITE. DO NOT DISCHARGE WATER IN THE HIGHWAY DRAINAGE SYSTEM OR WATERS OF THE UNITED STATES. CONTACT DRINKING WATER BRANCH, DEPARTMENT OF HEALTH AT (808) 586-4285 TO RECEIVE PERMISSION TO DESIGNATE A DISPOSAL SITE. CLEAN DISPOSAL SITE AS REQUIRED OR AS REQUESTED BY THE OWNER'S REPRESENTATIVE.

**4. SPILL CONTROL PLAN**

- a. POST A SPILL PREVENTION PLAN TO INCLUDE MEASURES TO PREVENT AND CLEANUP EACH SPILL.
- b. THE CONTRACTOR SHALL BE THE SPILL PREVENTION AND CLEANUP COORDINATOR. DESIGNATE AT LEAST THREE SITE PERSONNEL WHO SHALL RECEIVE SPILL PREVENTION AND CLEANUP TRAINING. THESE INDIVIDUALS SHALL EACH BECOME RESPONSIBLE FOR A PARTICULAR PHASE OF PREVENTION AND CLEANUP. POST THE NAMES OF RESPONSIBLE SPILL PERSONNEL IN THE MATERIAL STORAGE AREA AND IN THE OFFICE TRAILER ONSITE.
- c. CLEARLY POST MANUFACTURER'S RECOMMENDED METHODS FOR SPILL CLEANUP. MAKE SITE PERSONNEL AWARE OF THE PROCEDURES AND THE LOCATION OF THE INFORMATION AND CLEANUP SUPPLIES.
- d. KEEP MATERIALS AND EQUIPMENT NECESSARY FOR SPILL CLEANUP IN THE MATERIAL STORAGE AREA ONSITE.
- e. CLEANUP ALL SPILLS IMMEDIATELY AFTER DISCOVERY.
- f. KEEP THE SPILL AREA WELL VENTILATED. PERSONNEL SHALL WEAR APPROPRIATE PROTECTIVE CLOTHING TO PREVENT INJURY FROM CONTACT WITH A HAZARDOUS SUBSTANCE.
- g. REPORT SPILLS OF TOXIC HAZARDOUS MATERIAL TO THE APPROPRIATE STATE OR LOCAL GOVERNMENT AGENCY, REGARDLESS OF THE SIZE.

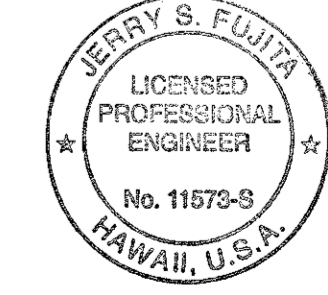
**F. NATIONAL POLLUTION DISCHARGE ELIMINATION SYSTEM (NPDES) REQUIREMENTS**

- 1. THE CONTRACTOR SHALL COMPLY WITH THE NATIONAL POLLUTION DISCHARGE ELIMINATION SYSTEM (NPDES) REQUIREMENTS FOR KAUAI DISTRICT OFFICE AT 3040 UMI STREET. DUE TO POTENTIAL COST IMPACTS, THE CONTRACTOR NEEDS TO BE AWARE OF THESE REQUIREMENTS.
- 2. THE CONTRACTOR SHALL OBTAIN AND COMPLY WITH THE NATIONAL POLLUTION DISCHARGE ELIMINATION SYSTEM (NPDES) PERMIT REQUIREMENTS FOR ALL PROJECTS WHICH WILL DISTURB ONE (1) ACRE OR MORE OF LAND. THE CONTRACTOR SHALL NOT START CONSTRUCTION UNTIL NOTICE OF GENERAL PERMIT COVERAGE (NGPC) IS RECEIVED FROM THE DEPARTMENT OF HEALTH, STATE OF HAWAII AND HAS SATISFIED ANY OTHER APPLICABLE REQUIREMENTS OF THE NPDES PERMIT PROGRAM.
- 3. THE CONTRACTOR SHALL COMPLETE AND SUBMIT A CONTRACTOR'S CERTIFICATION OF NPDES COMPLIANCE, INCLUDING COMPLETION OF THE BEST MANAGEMENT PRACTICE (BMP) CHECKLIST AND SUBMITTAL OF A WRITTEN BMP PLAN AND DRAWINGS, PRIOR TO ISSUANCE OF A GRADING PERMIT.

REVISION	DATE	DESCRIPTION	BY	APPROVED

**REHABILITATE PAUA VALLEY TANK #1**

**BMP NOTES, RESERVOIR WATER DISCHARGE NOTES**



LICENSED PROFESSIONAL ENGINEER  
No. 11573-B  
HAWAII, U.S.A.

APPROVED: *[Signature]* 1/18/19  
MANAGER & CHIEF ENGINEER  
DEPT. OF WATER, COUNTY OF KAUAI

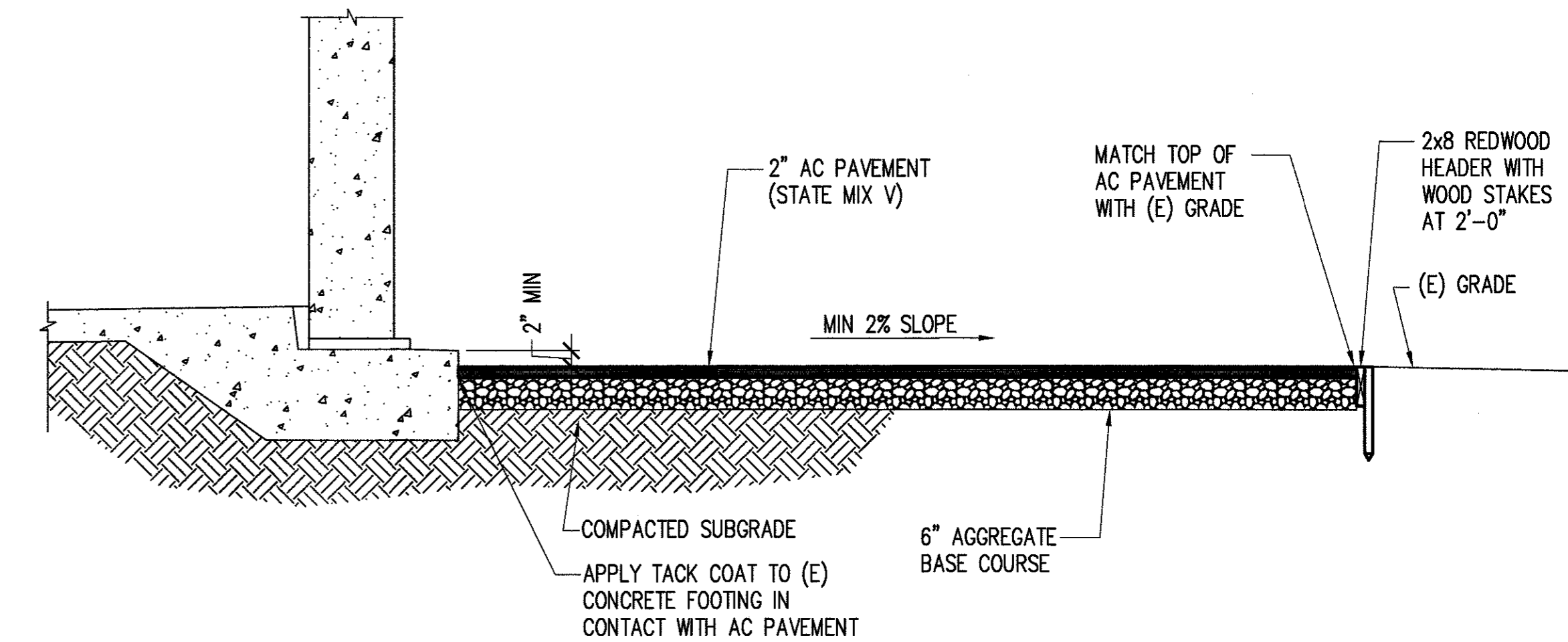
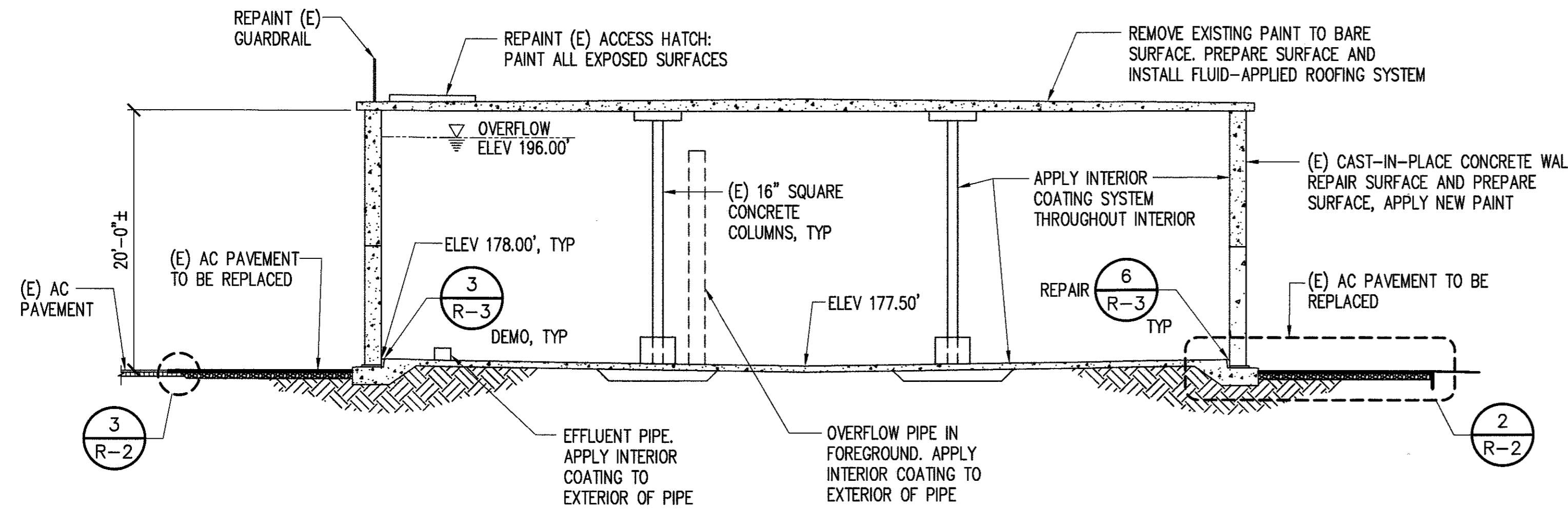
This work was prepared by me or under my supervision and construction to this project will be under my observation.

Expiration Date of License 04-30-20

PA4301-4350\4339 DWS - Rehabilitate Paua Valley Tank #1, 0.5 MG Concrete, Kekaha\004 Drawings\Structural\AutocAD, format\2019-01-09, 4339 DWS Paua\4339, T-3.dwg, 1/10/2019 3:43:47 PM, dykokomizo

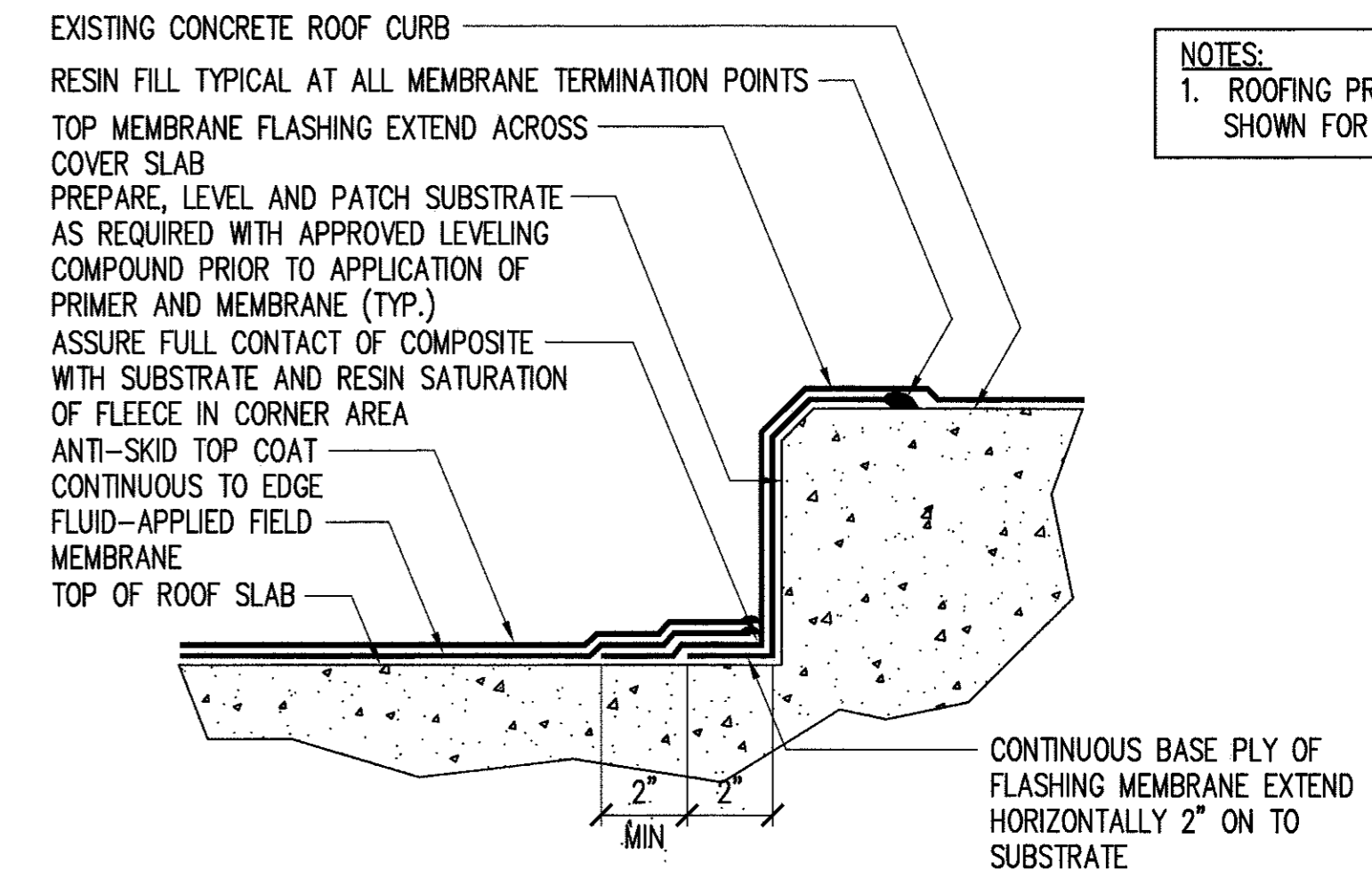
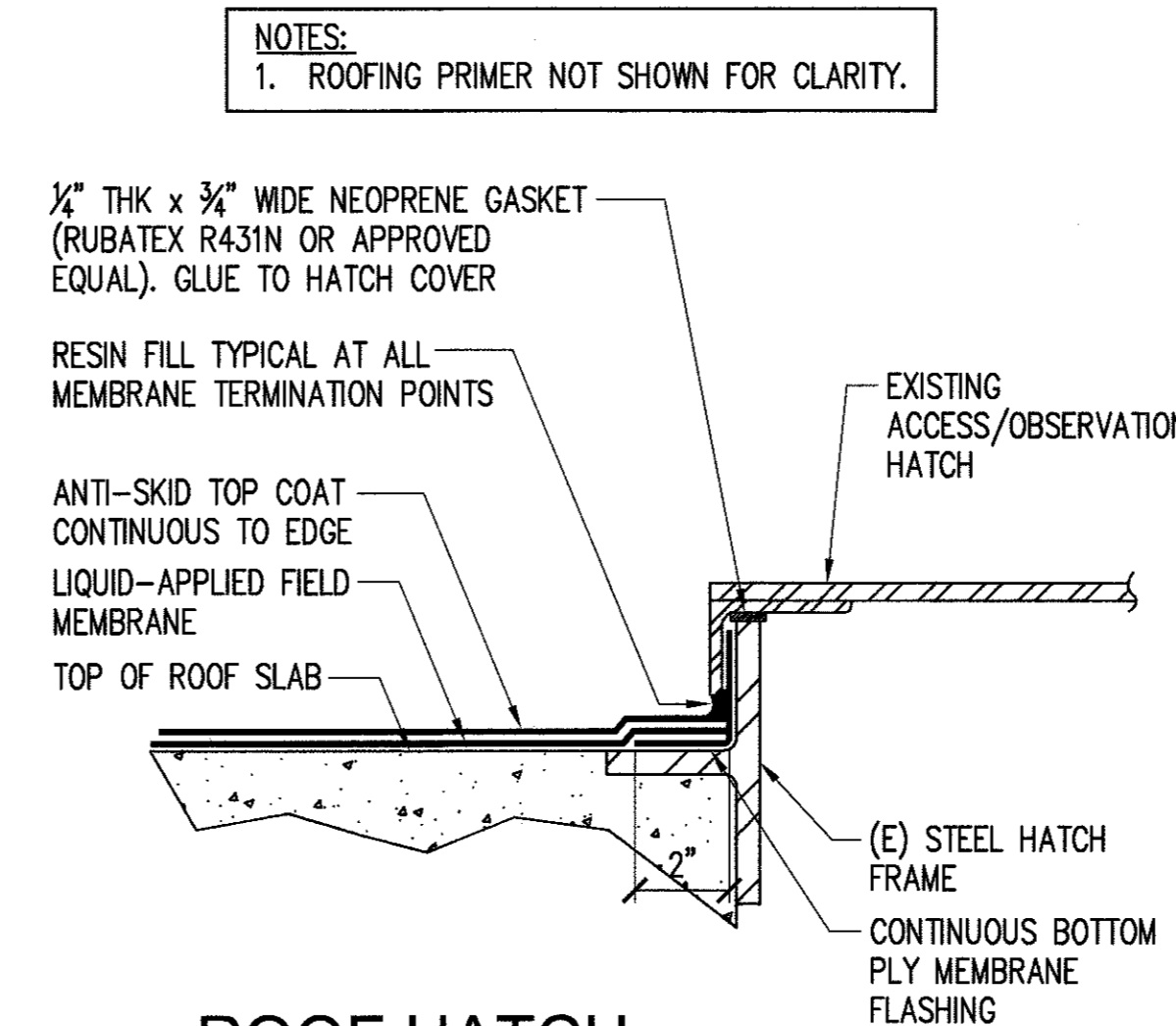
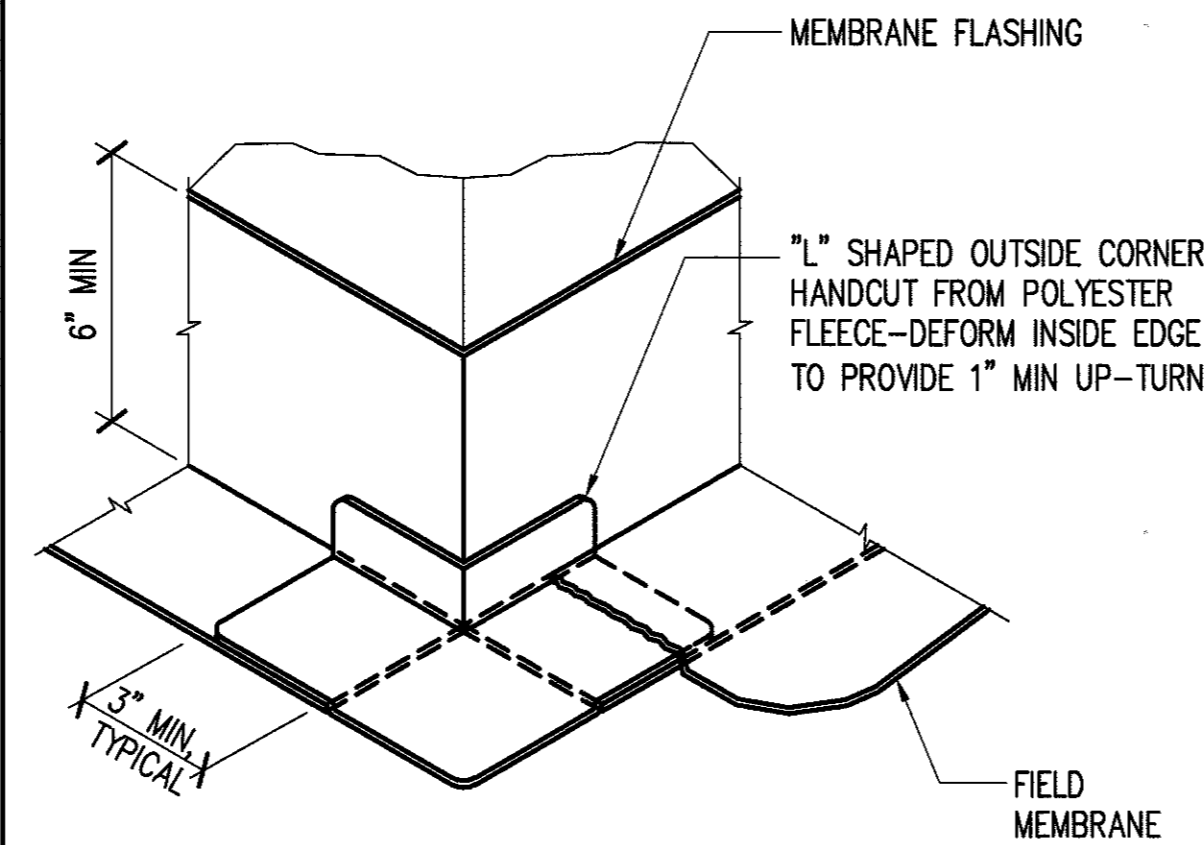
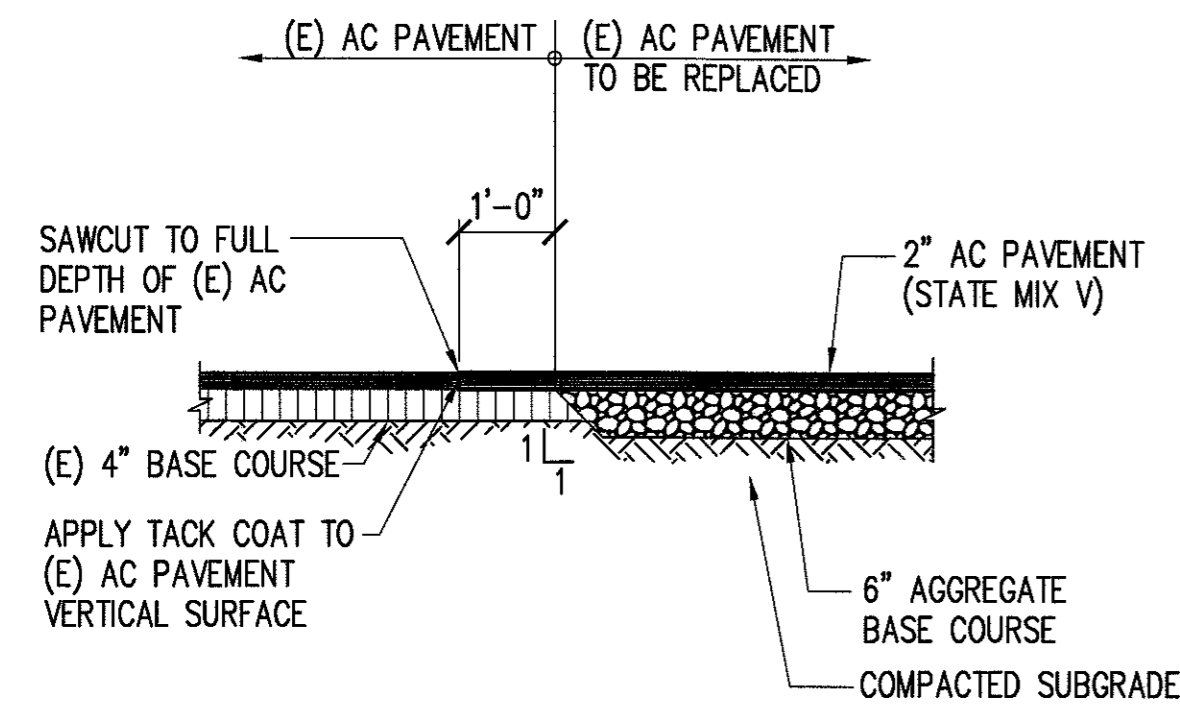






1 RESERVOIR CROSS SECTION  
 R-2 SCALE: 1/8" = 1'-0"

2 TYPICAL ROADWAY SECTION  
 R-2 SCALE: 1/2" = 1'-0"

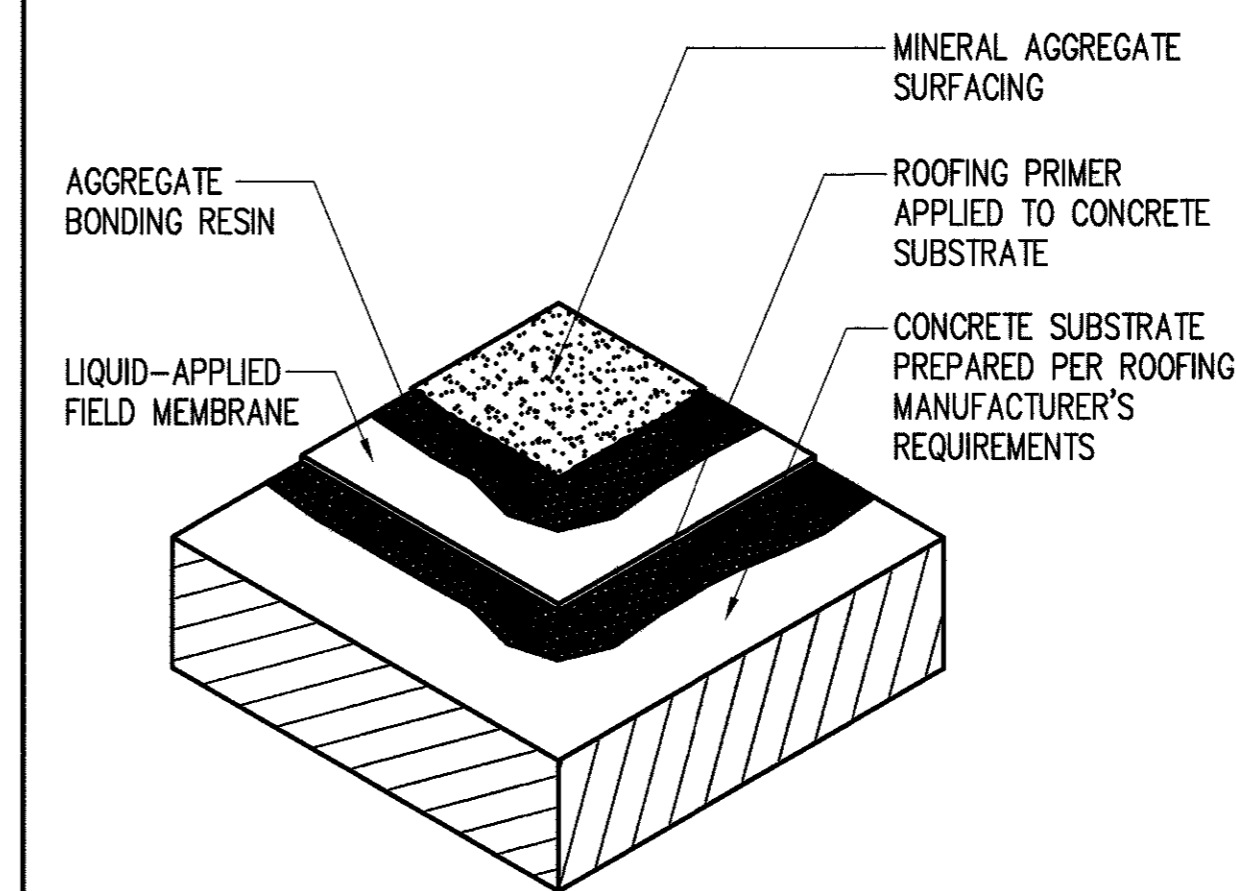
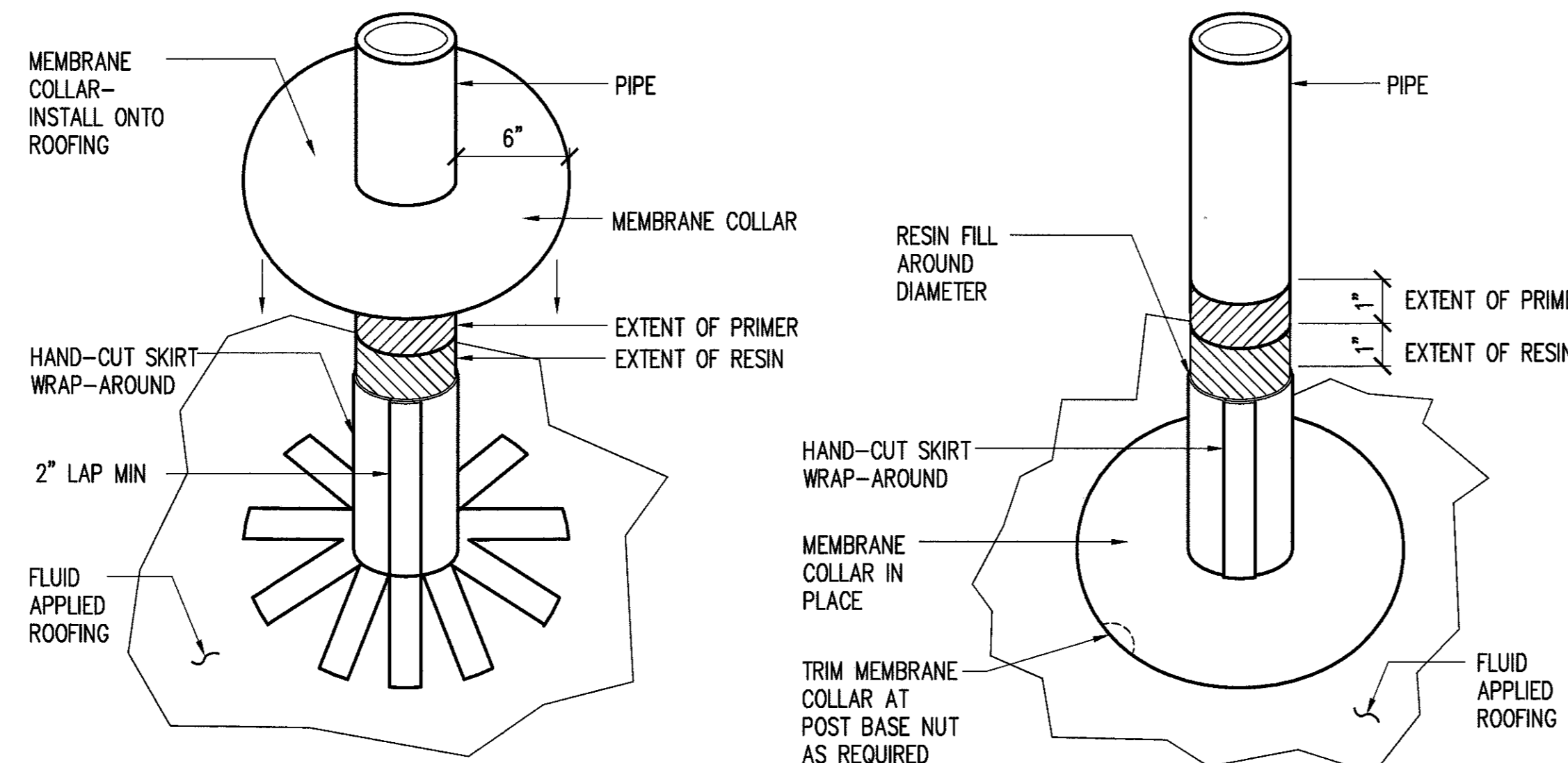
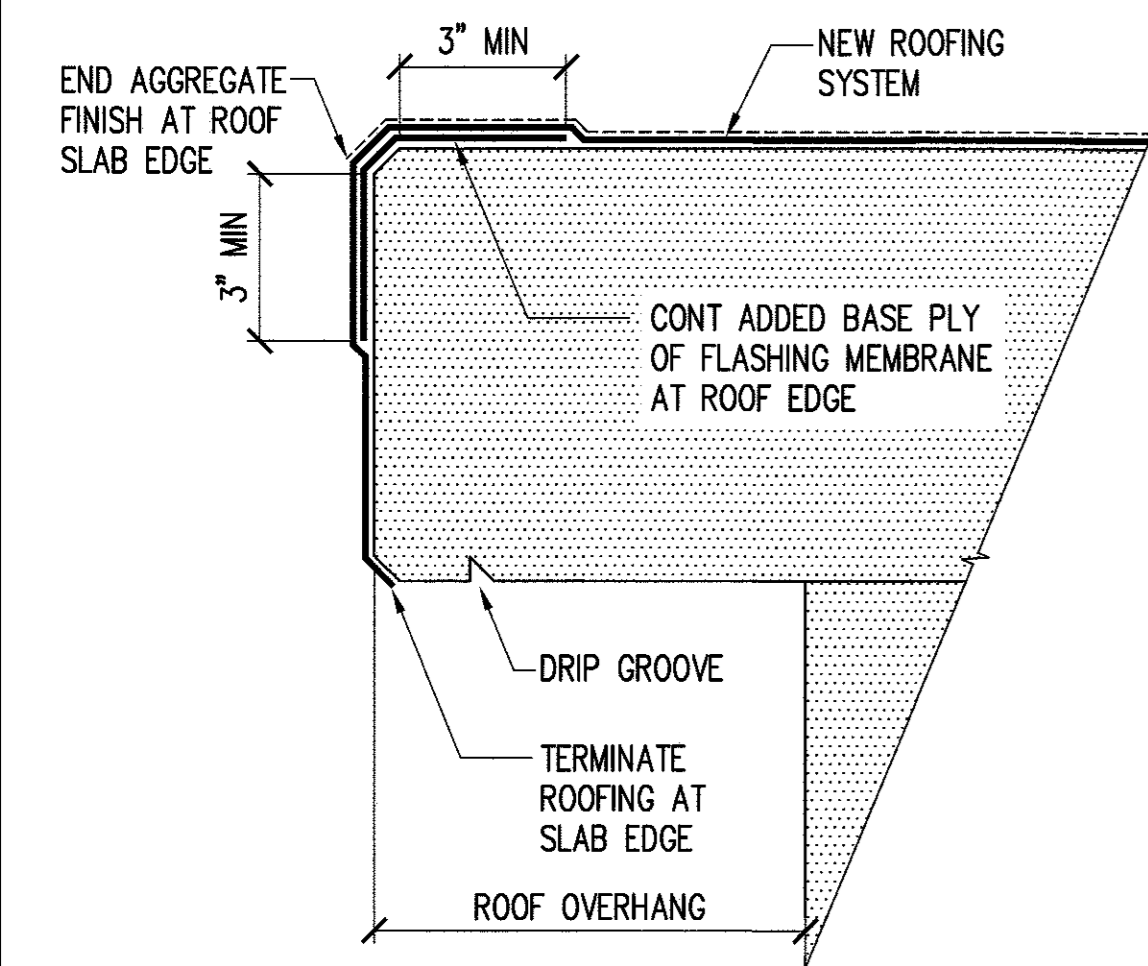


3 NEW TO (E) AC PAVEMENT DETAIL  
 R-2 SCALE: 1/2" = 1'-0"

4 TYPICAL MEMBRANE CORNER DETAIL  
 R-2 NOT TO SCALE

5 ROOF HATCH FRAME FLASHING DETAIL  
 R-2 NOT TO SCALE

6 ACCESS HATCH COVER SLAB FLASHING DETAIL  
 R-2 NOT TO SCALE



7 ROOFING AT ROOF EDGE  
 R-2 NOT TO SCALE

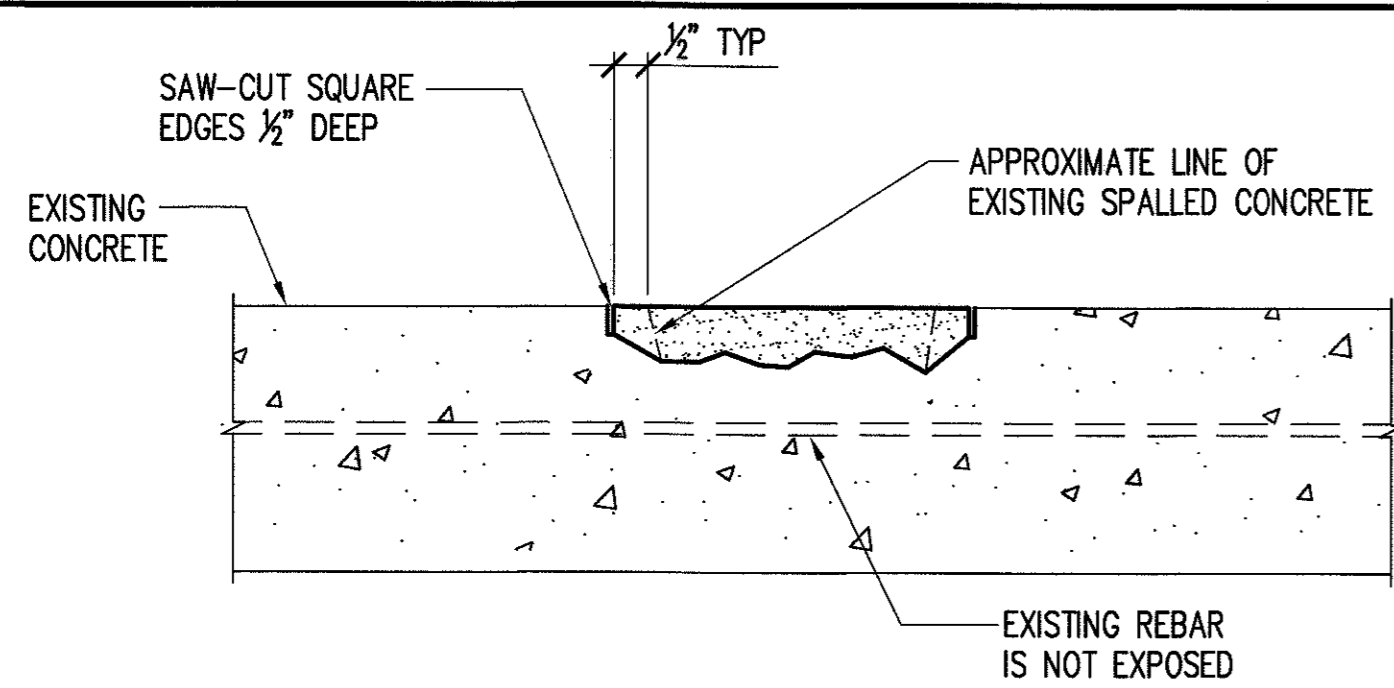
8 TYPICAL PIPE SEALING DETAIL  
 R-2 NOT TO SCALE

9 TYPICAL LIQUID-APPLIED ROOFING ASSEMBLY DETAIL  
 R-2 NOT TO SCALE

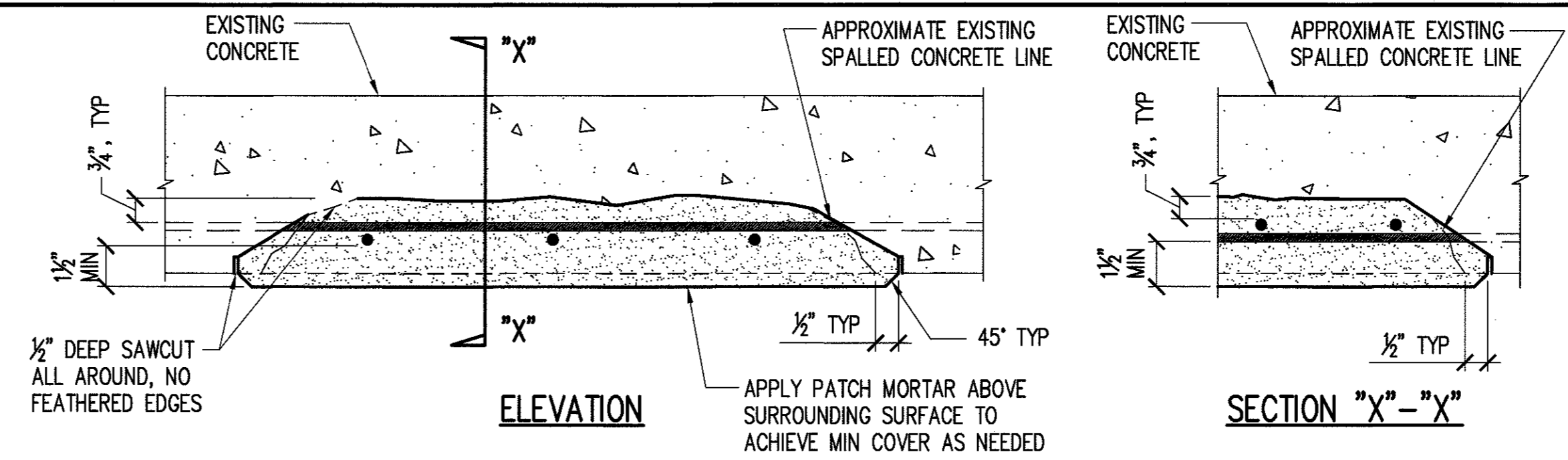
REVISION	DATE	DESCRIPTION	BY	APPROVED

**REHABILITATE PAUA VALLEY TANK #1**  
 RESERVOIR CROSS SECTION AND DETAILS

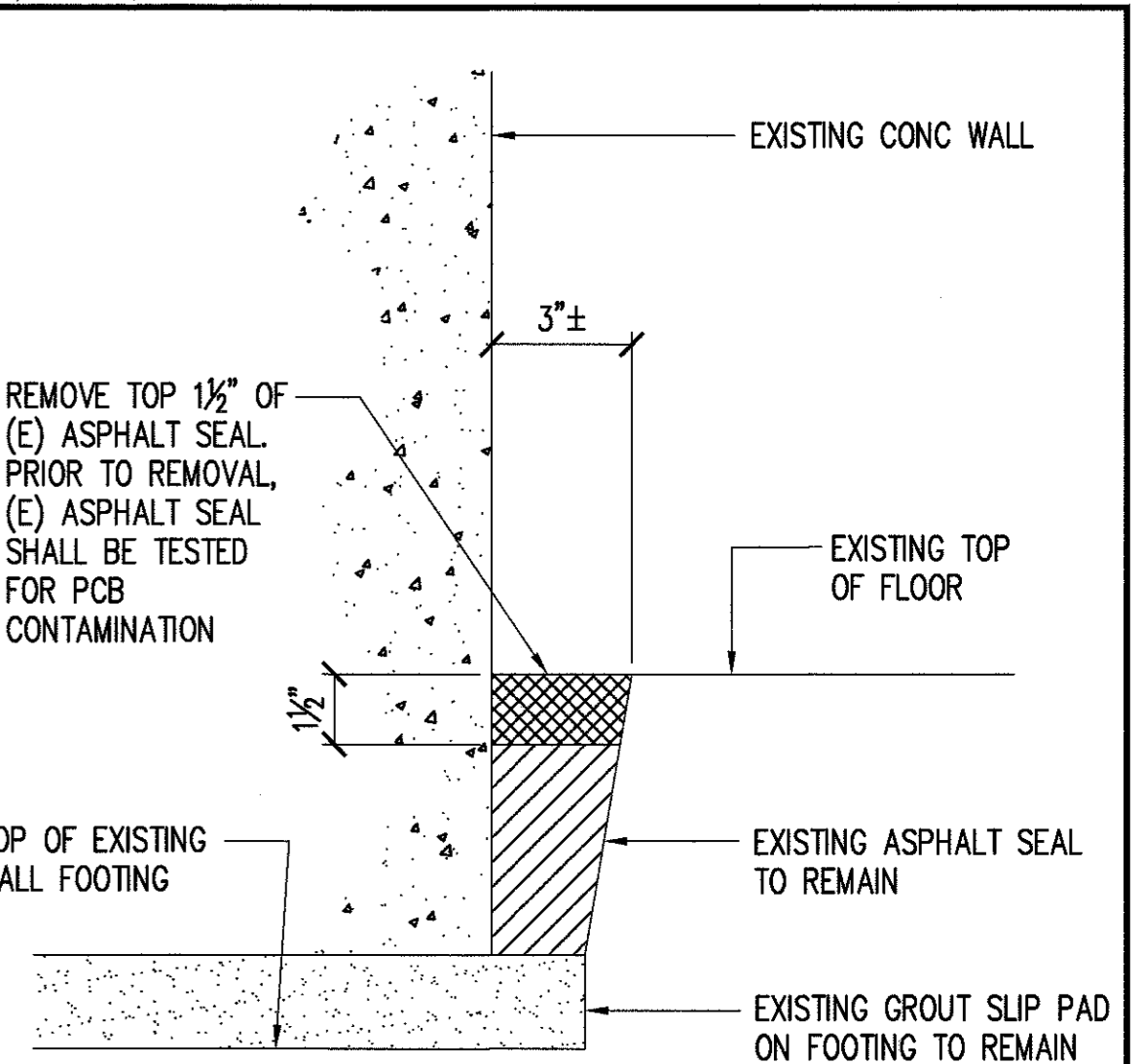
APPROVED: *Jerry S. Fujita* 1/18/19  
 LICENSED PROFESSIONAL ENGINEER  
 No. 11573-S  
 HAWAII, U.S.A.  
 This work was prepared by me or under my supervision and construction to this project will be under my observation.  
 Expiration Date of License 09-30-20



- NOTES:**
- CLEAN AND PREPARE CONCRETE ACCORDING TO THE SURFACE PREPARATION NOTES BELOW.
  - SUBSTRATE SHALL BE SATURATED SURFACE DRY (SSD) WITH NO STANDING WATER.
  - APPLY CORROSION INHIBITING BONDING AGENT TO ALL SURFACES TO BE PATCHED.
  - APPLY POLYMER MODIFIED PATCHING MORTAR TO REPAIR AREAS TO ORIGINAL FINISH LINES.
  - MAXIMUM PATCHING LAYER THICKNESS SHALL BE LIMITED TO MANUFACTURER'S SPECIFICATIONS.
  - PATCHED CONCRETE SHALL MATCH SURROUNDING AREA ELEVATION AND FINISH.



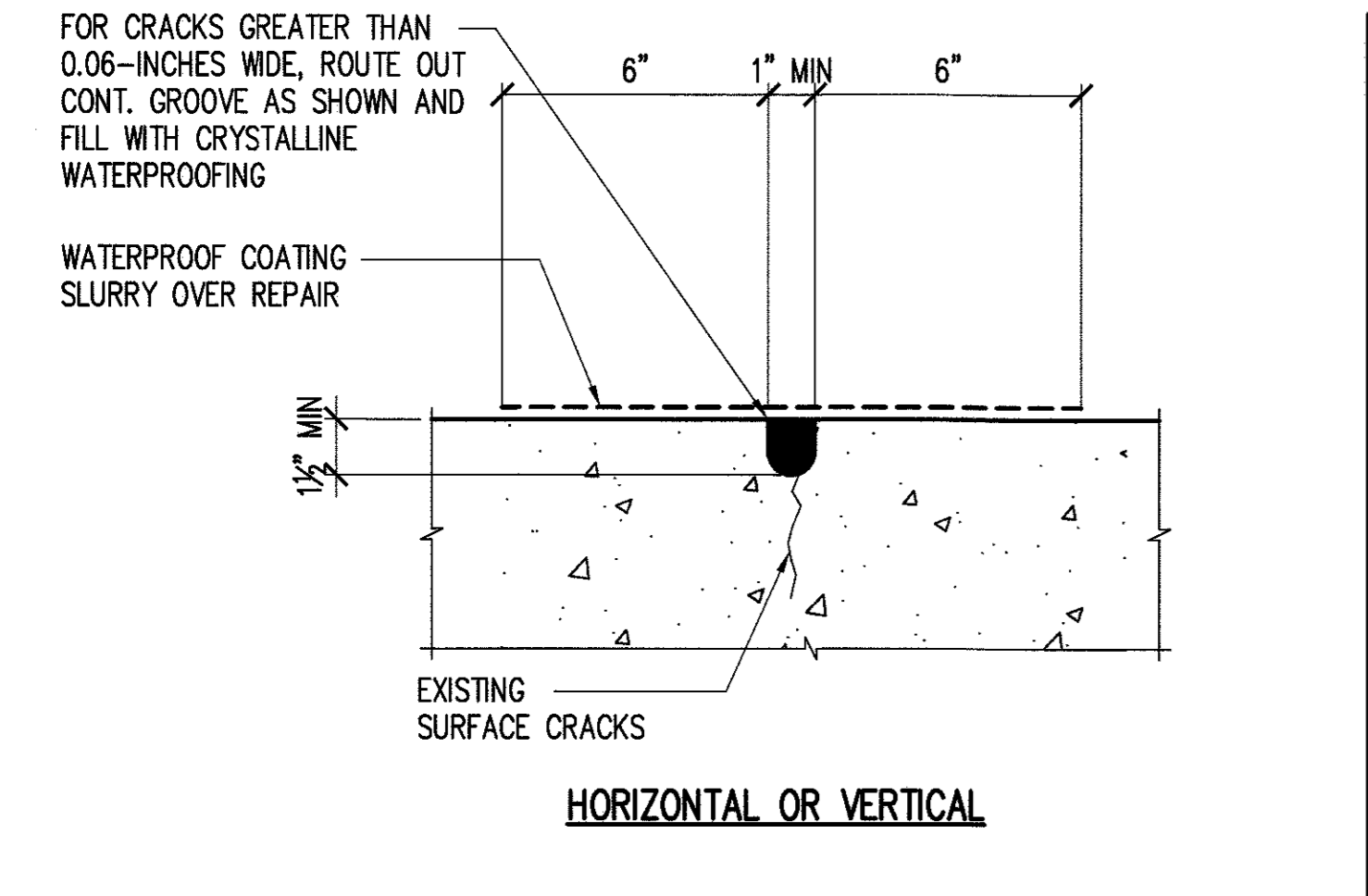
- NOTES:**
- CLEAN AND PREPARE CONCRETE ACCORDING TO THE SURFACE PREPARATION NOTES BELOW.
  - CLEAN ANY EXPOSED REINFORCEMENT BY SANDBLASTING OR WITH A WIRE BRUSH, REMOVING ALL CORROSION, OIL, DIRT AND ALL OTHER BOND INHIBITING AGENTS.
  - APPLY CORROSION INHIBITING BONDING AGENT TO ALL SURFACES TO BE PATCHED, INCLUDING REINFORCING STEEL.
  - APPLY POLYMER MODIFIED PATCHING MORTAR TO REPAIR AREAS TO ORIGINAL FINISH LINES, OR UNTIL A MINIMUM OF 1 1/2" OF COVER OVER REINFORCING STEEL IS OBTAINED, WHICHEVER IS THICKER.
  - MAXIMUM PATCHING LAYER THICKNESS SHALL BE LIMITED TO MANUFACTURER'S SPECIFICATIONS. IF REPAIR DEEPER THAN PERMITTED LAYER THICKNESS APPLY REPAIR IN MULTIPLE LIFTS IN ACCORDANCE WITH MANUFACTURER'S SPECIFICATIONS.



**EXISTING SEALANT AT WALL JOINT DEMO**  
SCALE: 3" = 1'-0"

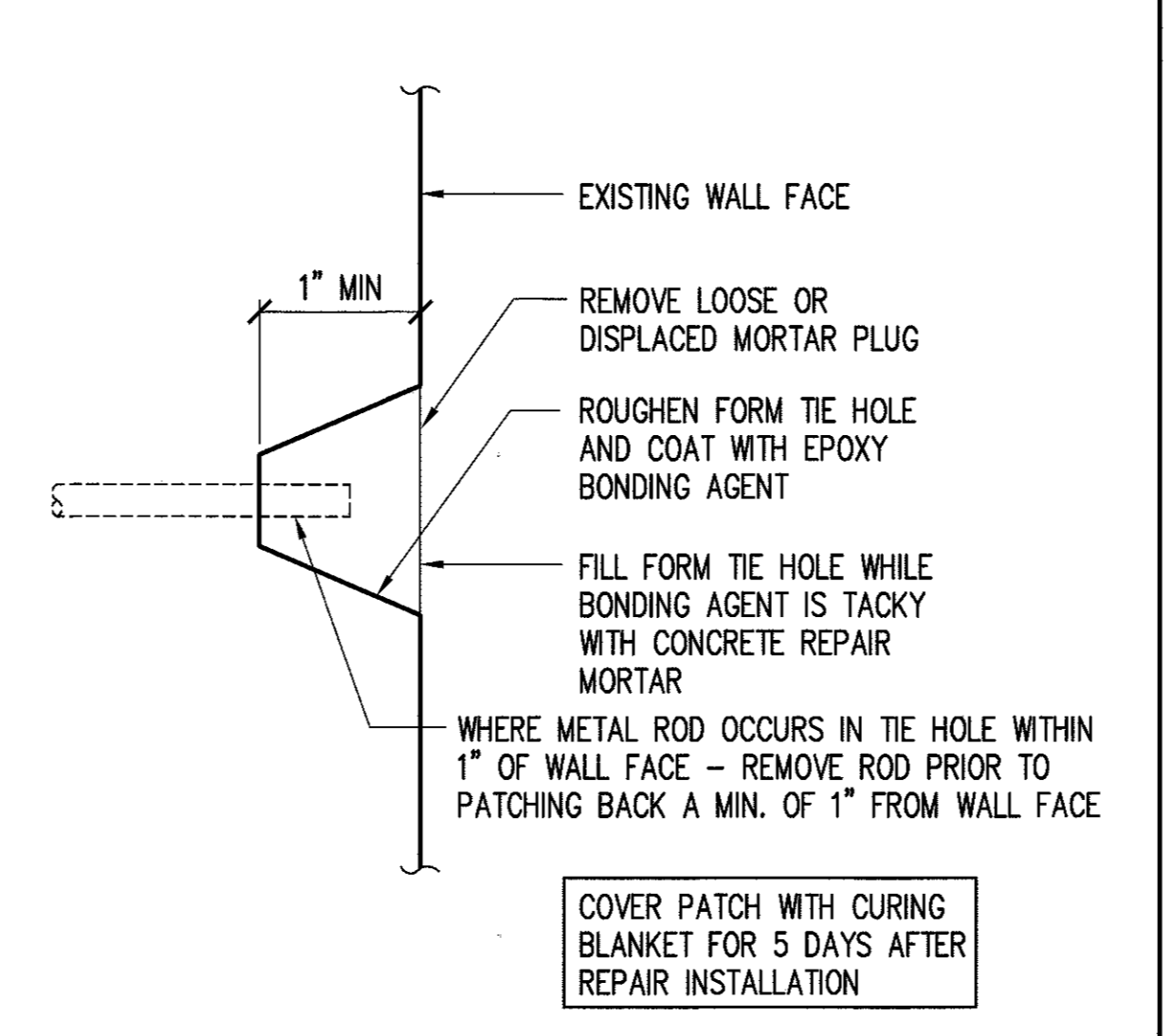
**1 TYPE I SPALL (WITHOUT EXPOSED REBAR) REPAIR DETAIL**  
R-3 NOT TO SCALE

**2 TYPE II SPALL (WITH EXPOSED REBAR) REPAIR DETAIL**  
R-3 NOT TO SCALE

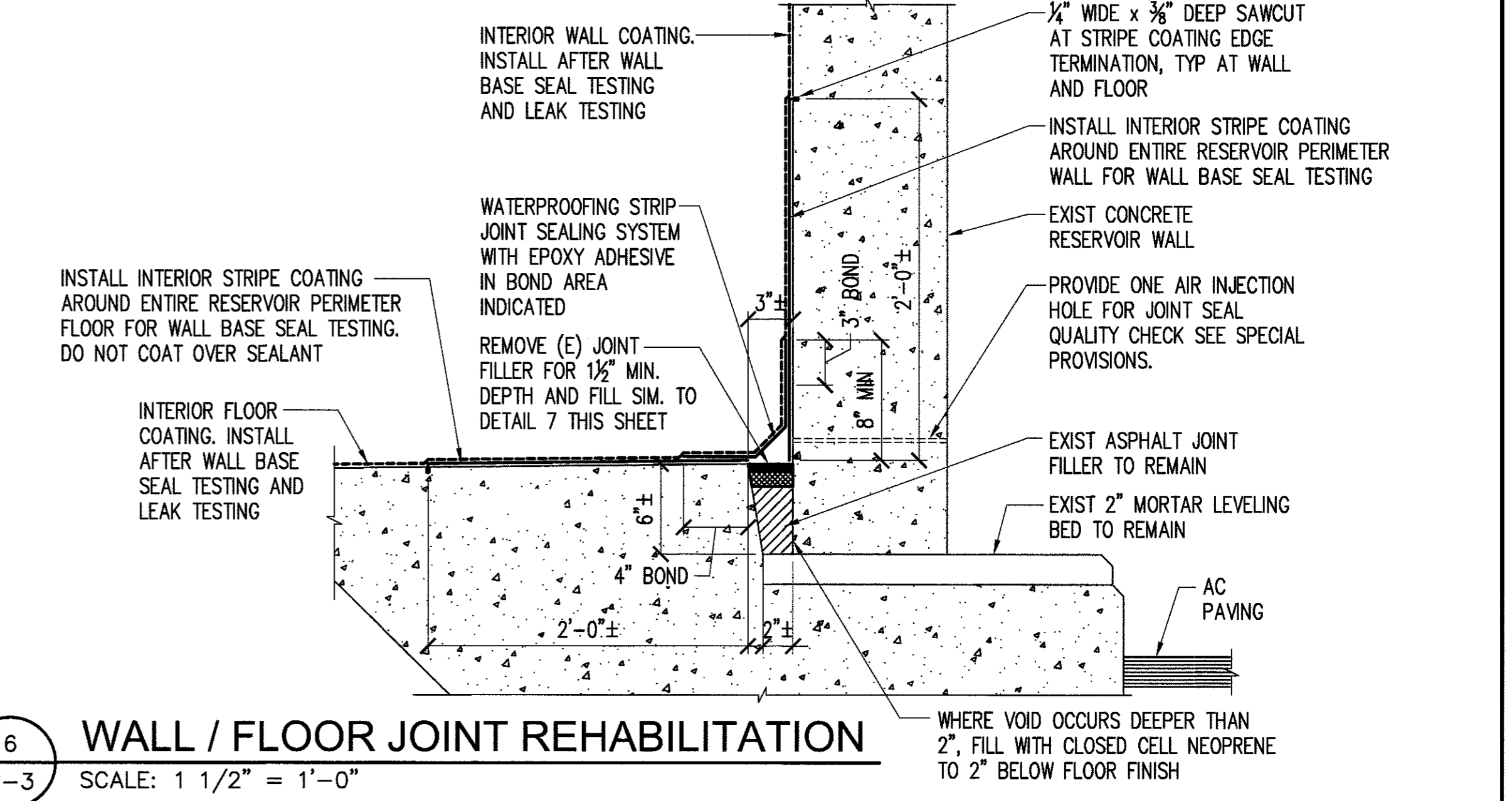


- CRACK REPAIR NOTES:**
- ROUTE OUT TO DIMENSIONS RECOMMENDED BY THE MANUFACTURER OR SHOWN TO SOUND CONCRETE.
  - WET EXPOSED CONCRETE SURFACE.
  - APPLY COAT OF CRYSTALLINE SLURRY TO WETTED SURFACE.
  - WHILE SLURRY IS STILL TACKY, FILL GROOVE WITH CRYSTALLINE MORTAR MIXED TO DRY PACK CONSISTENCY. COMPRESS TIGHTLY WITH PACKING DEVICE OR USE HAMMER AND BLOCK AND FINISH FLUSH WITH SURROUNDING SURFACE.
  - LIGHTLY WET REPAIR SURFACE, THEN APPLY SLURRY COAT OF CRYSTALLINE WATERPROOFING OVER AREA.
  - CURE REPAIR AREA AS RECOMMENDED BY MANUFACTURER.

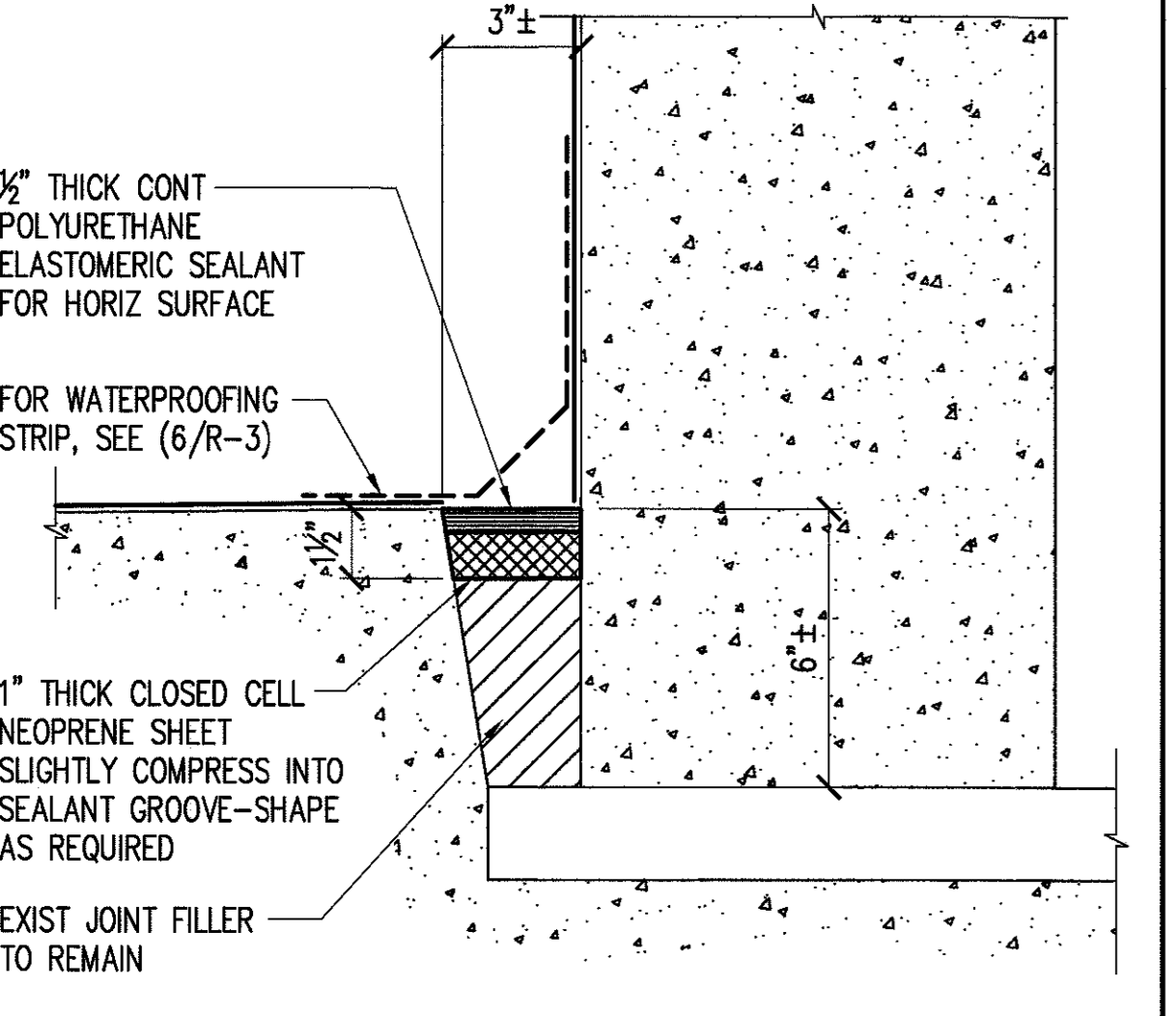
**4 TYPICAL ROUTING OF LARGER CRACK (0.06" OR LARGER) AND SEALING CRACKS**  
R-3 NOT TO SCALE



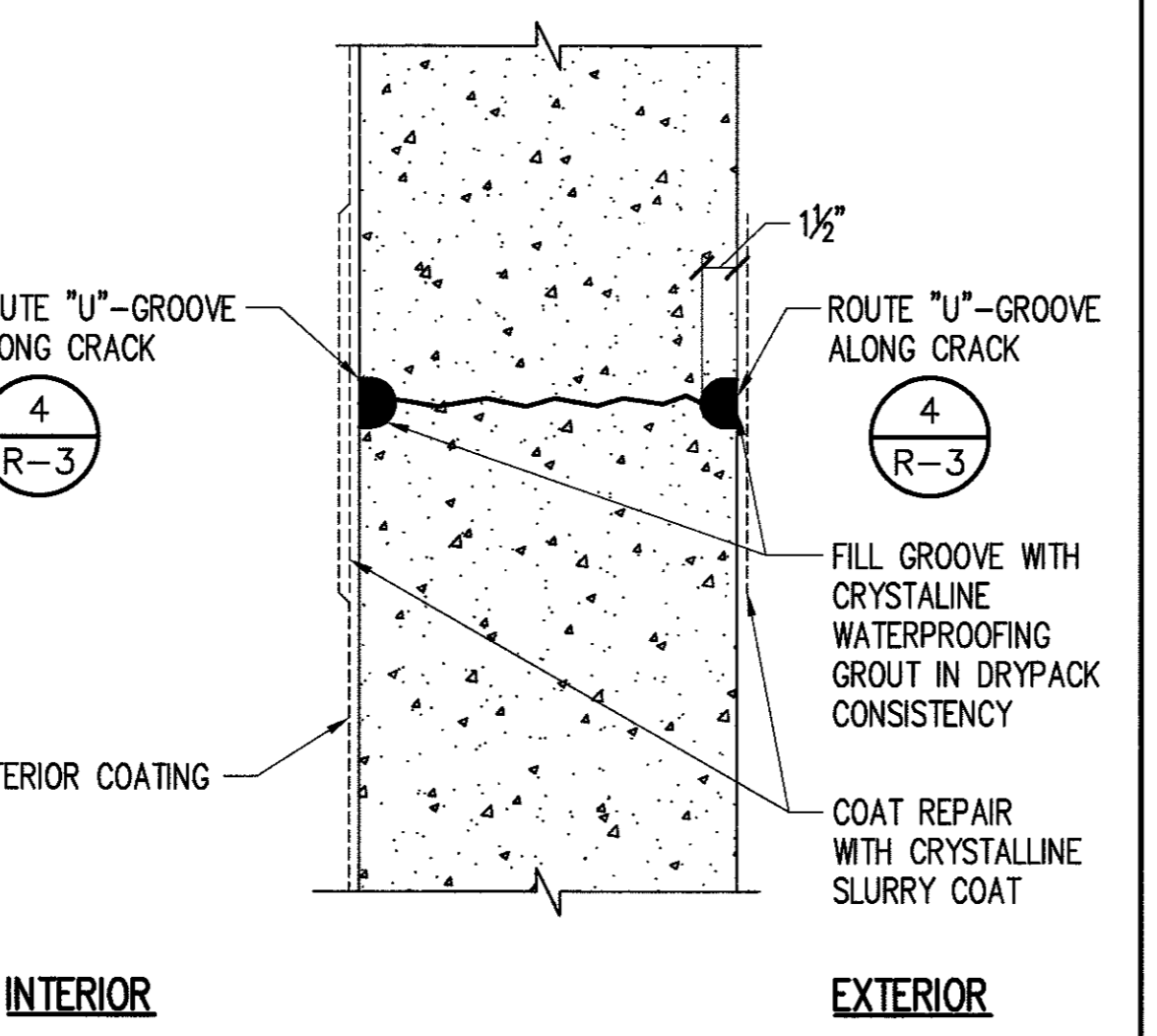
**5 FORM TIE HOLE REPAIR**  
R-3 NOT TO SCALE



**6 WALL / FLOOR JOINT REHABILITATION**  
SCALE: 1 1/2" = 1'-0"



**7 WALL BASE SEALANT**  
R-3 NOT TO SCALE

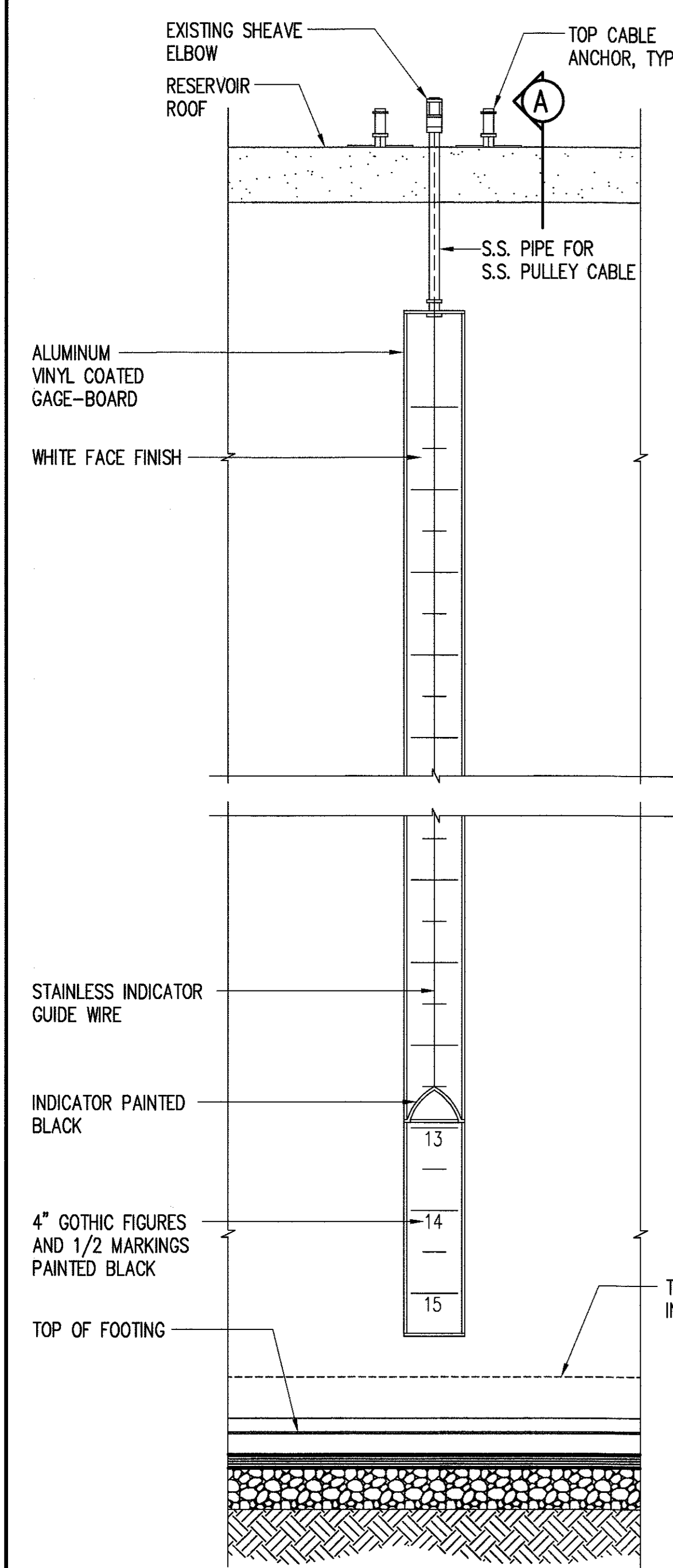


**8 WALL CRACK REPAIR AT LEAK**  
SCALE 1 1/2" = 1'-0"

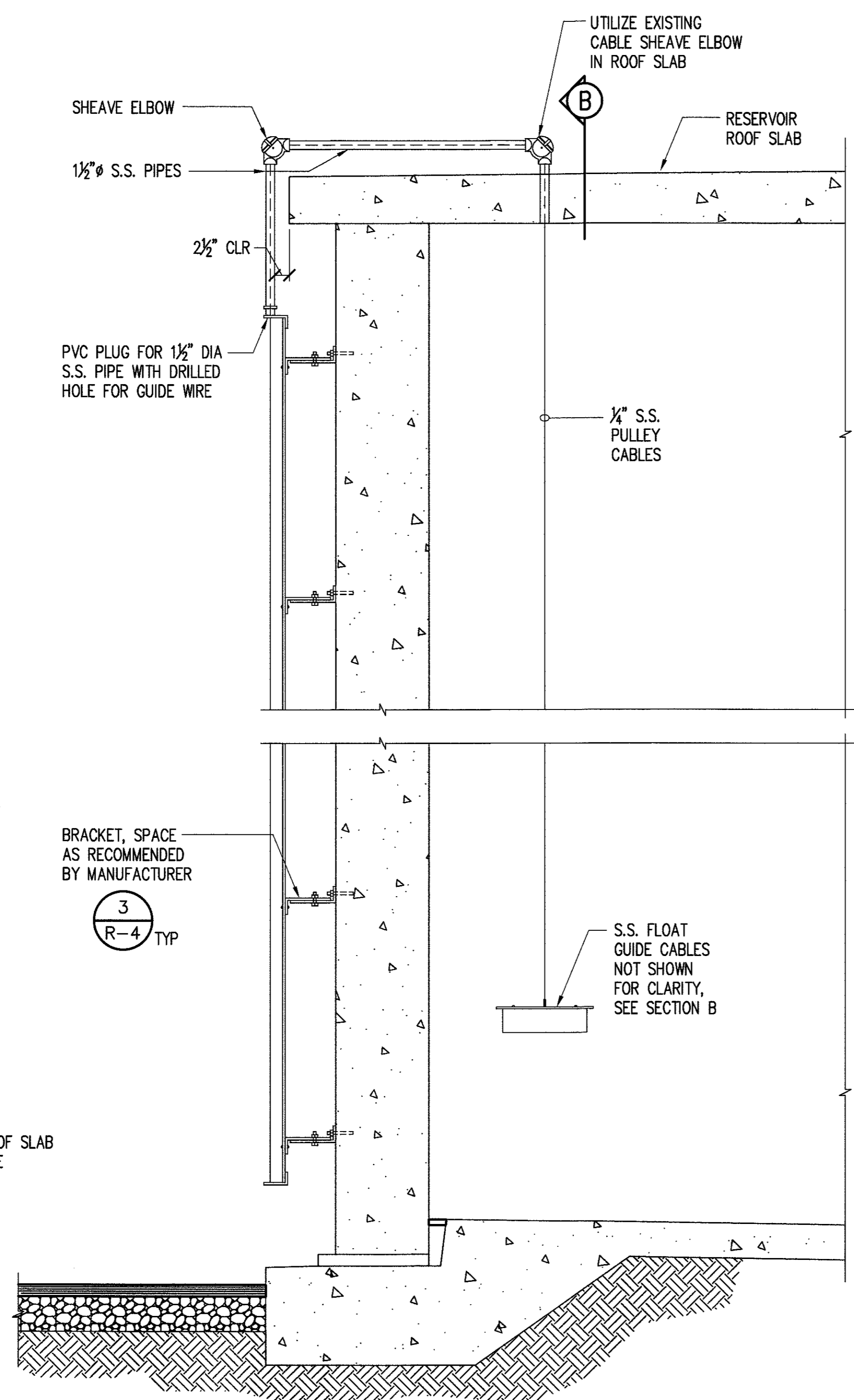
REVISION	DATE	DESCRIPTION	BY	APPROVED
<b>REHABILITATE PAUA VALLEY TANK #1</b>				
<b>RESERVOIR REPAIR DETAILS</b>				
		APPROVED: JERRY S. FUJITA LICENSED PROFESSIONAL ENGINEER No. 11572-S HAWAII, U.S.A. 1/18/19		
This work was prepared by me or under my supervision and construction to this project will be under my observation. Expiration Date of License: 04-30-20				
<b>KAI HAWAII, INC.</b> HONOLULU, OAHU, HAWAII, 96813				
DRAWING NO. R-3		DESIGNED BY: CAD		DATE: 1-09-19
				SHEET 6 OF 8 SHEETS

P:\4301-4350\4339 DWS - Rehabilitate Paua Valley Tank #1 - 0.5 MG Concrete, Kekaha\004 Drawings\Structural\AutoCAD - format\2019-01-09\_4339 DWS Paua\4339 R-3.dwg, 1/10/2019 3:47:26 PM, dyokomizo

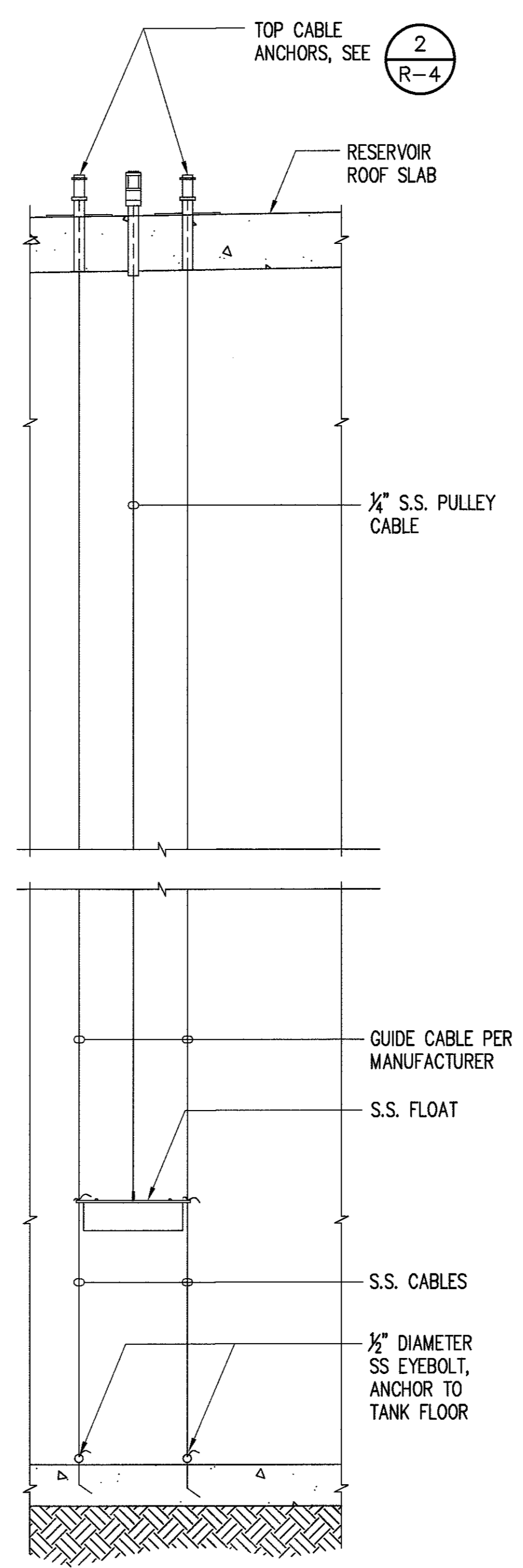
PROVIDE VAREC 6700 LEVEL INDICATOR FOR BULK STORAGE SYSTEM OR APPROVED EQUAL



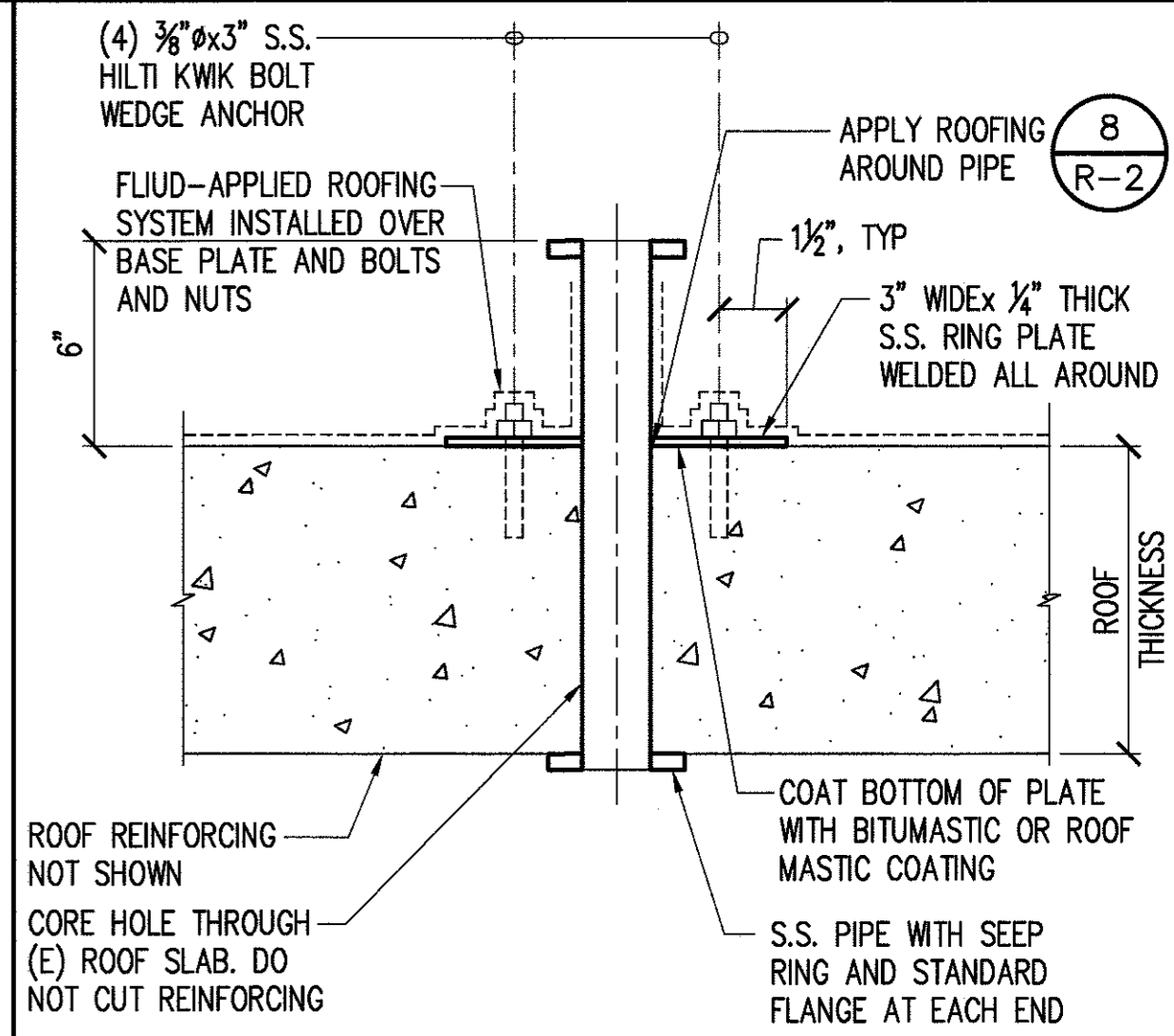
EXTERIOR ELEVATION



A SECTION

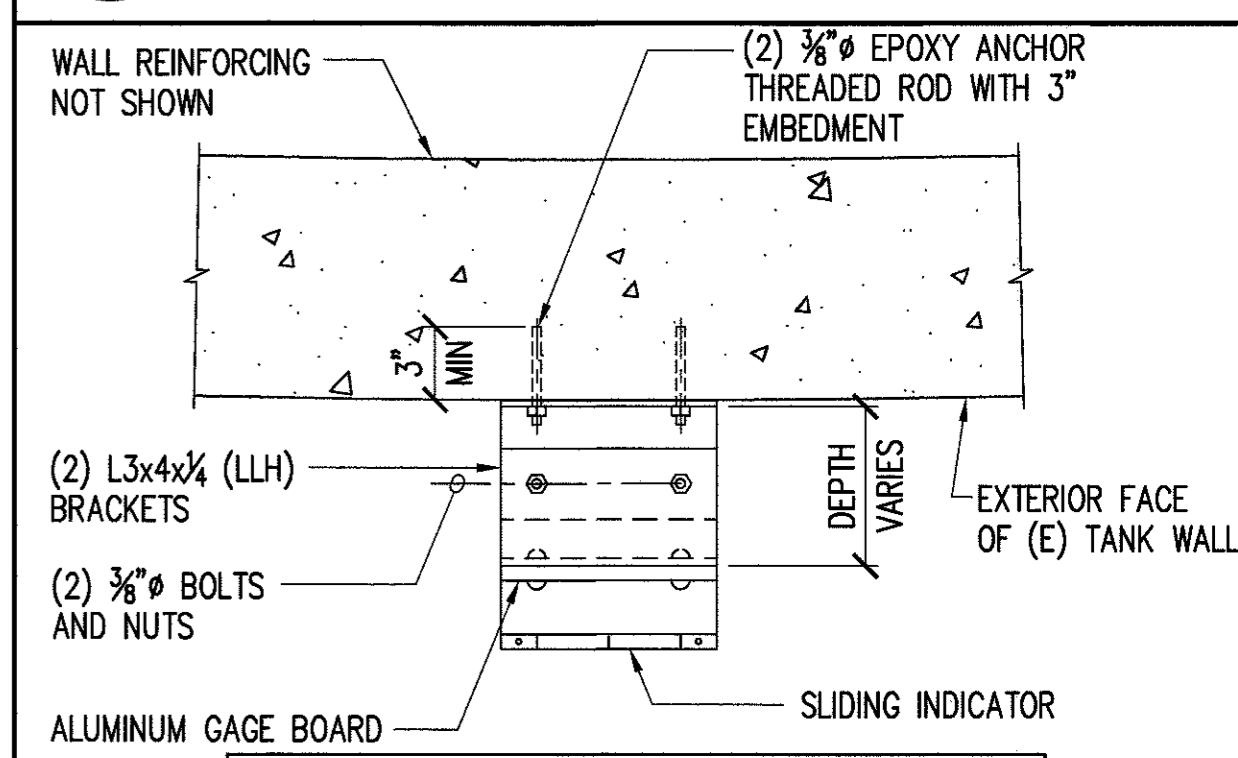


B SECTION



TYPICAL CABLE PIPE THROUGH ROOF

2 R-4 NOT TO SCALE



INDICATOR BRACKET PLAN DETAIL

3 R-4 SCALE: 1 1/2" = 1'-0"

1 R-4 WATER LEVEL INDICATOR NOT TO SCALE

REVISION	DATE	DESCRIPTION	BY	APPROVED

REHABILITATE PAUA VALLEY TANK #1

LEVEL INDICATOR DETAILS

APPROVED: *[Signature]* 1/18/19 DATE

**JERRY S. FUJITA**  
 LICENSED PROFESSIONAL ENGINEER  
 No. 11573-S  
 HAWAII, U.S.A.

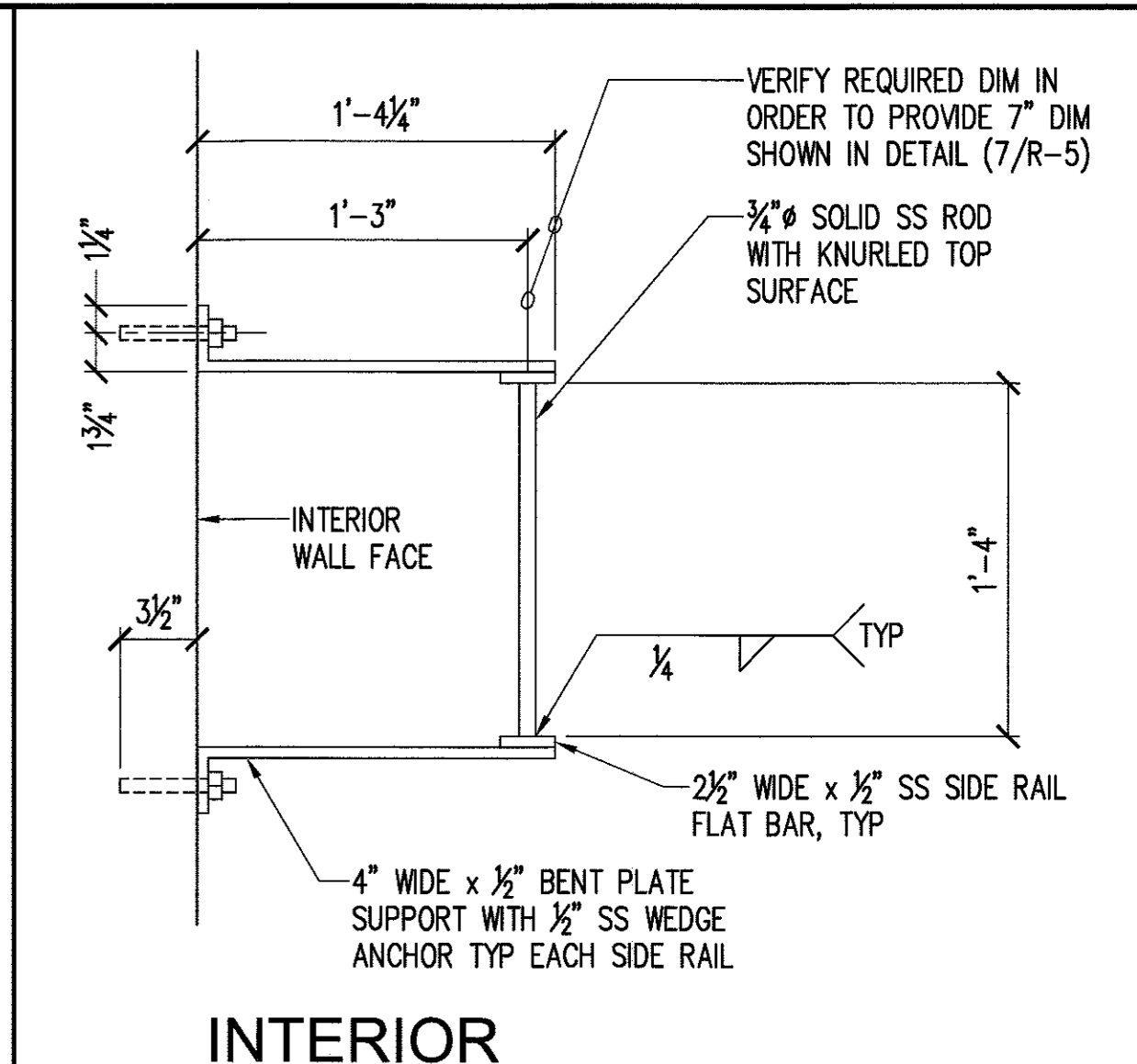
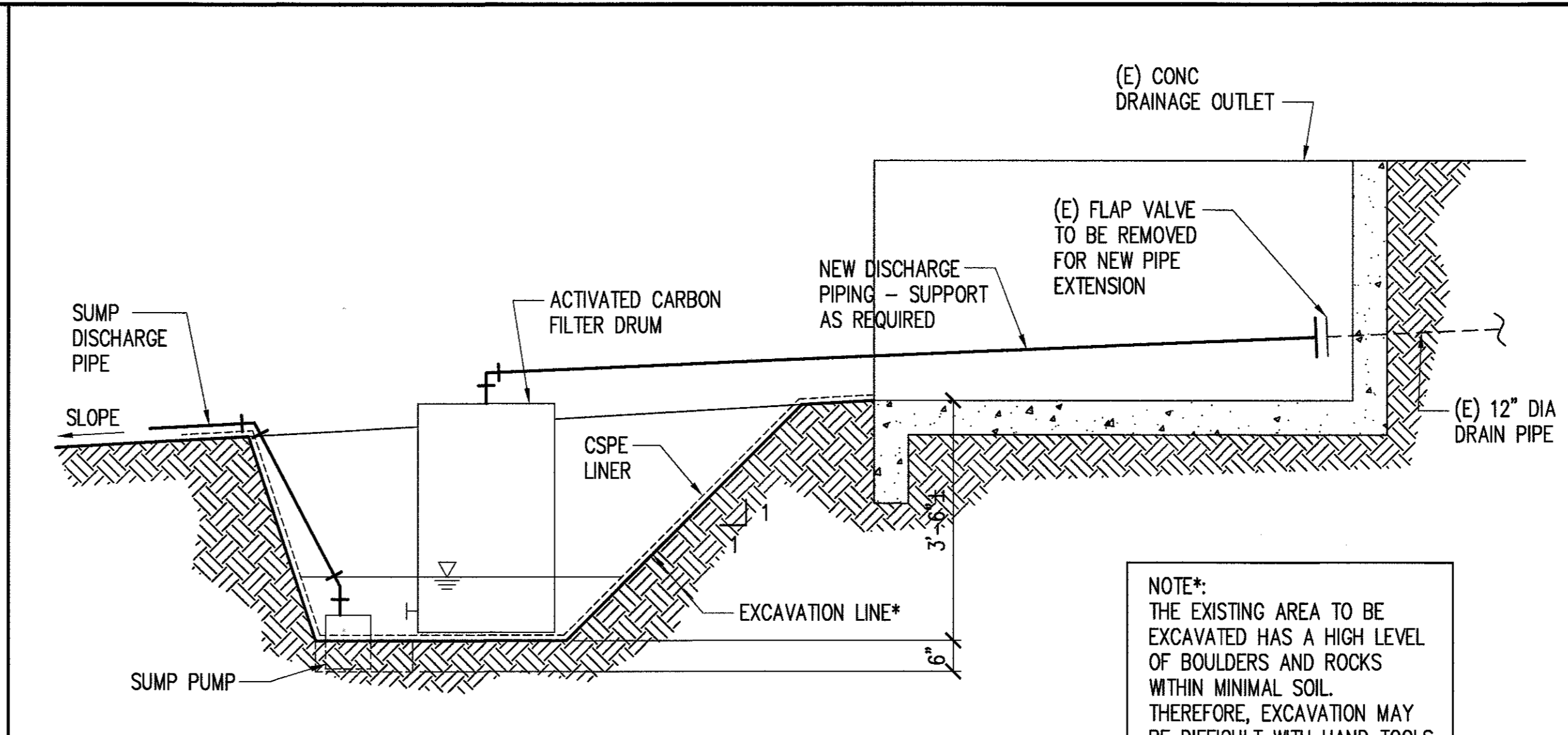
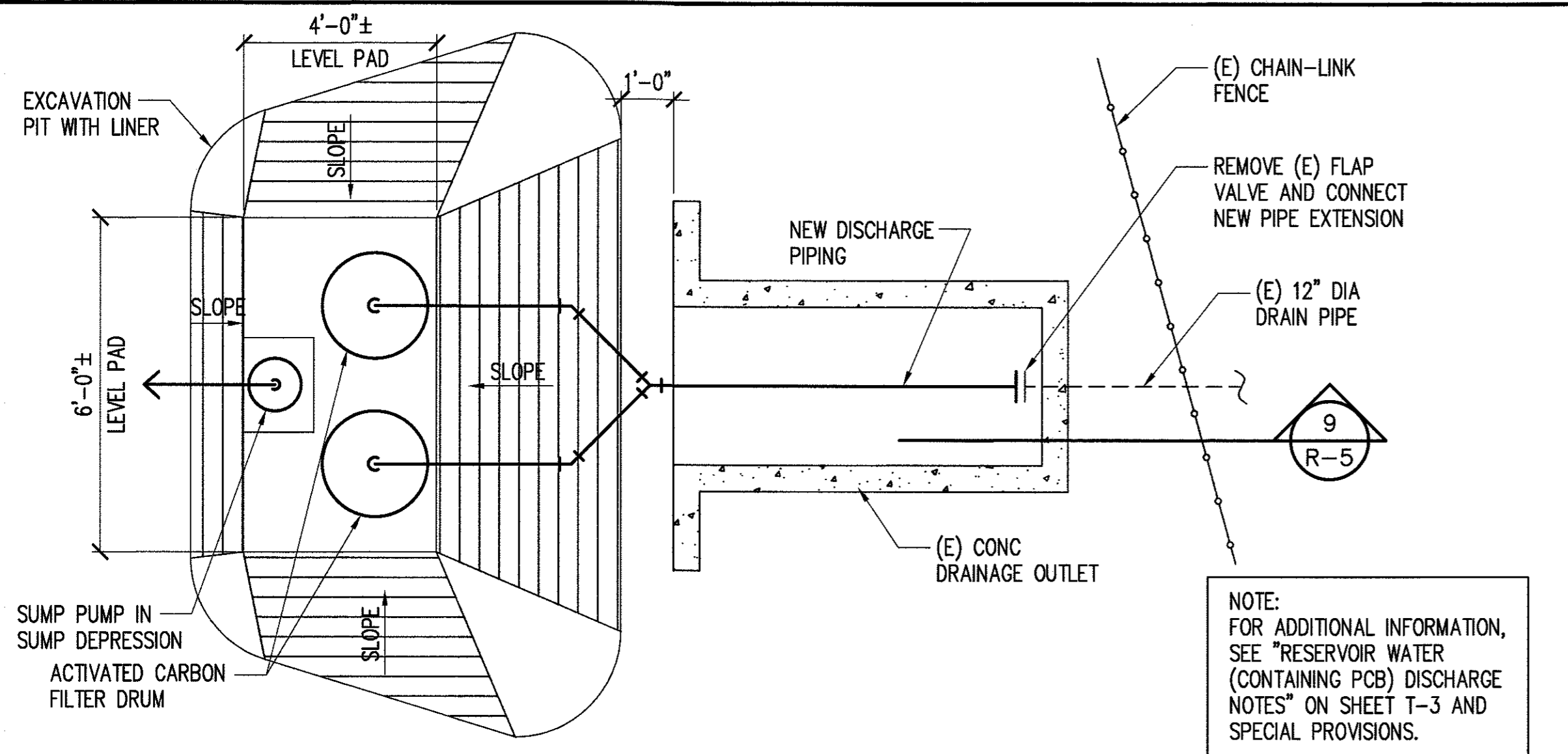
This work was prepared by me or under my supervision and construction to this project will be under my observation.

*[Signature]*  
 Expiration Date of License 04-30-20

KAI HAWAII, INC.  
 HONOLULU, OAHU, HAWAII, 96813

DESIGNED BY: DY DRAWN BY: CAD DATE: 1-09-19 SHEET 7 OF 8 SHEETS

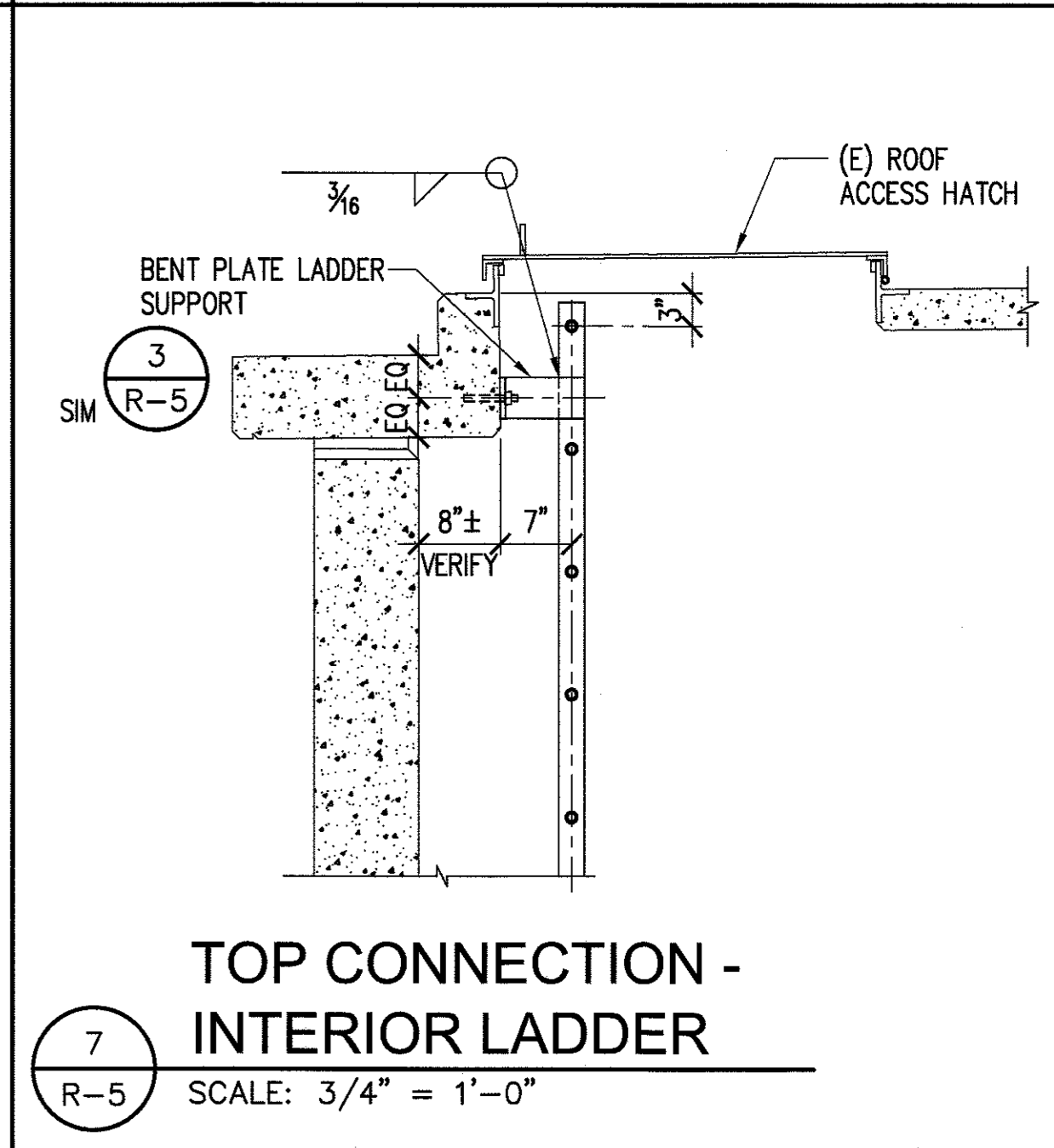
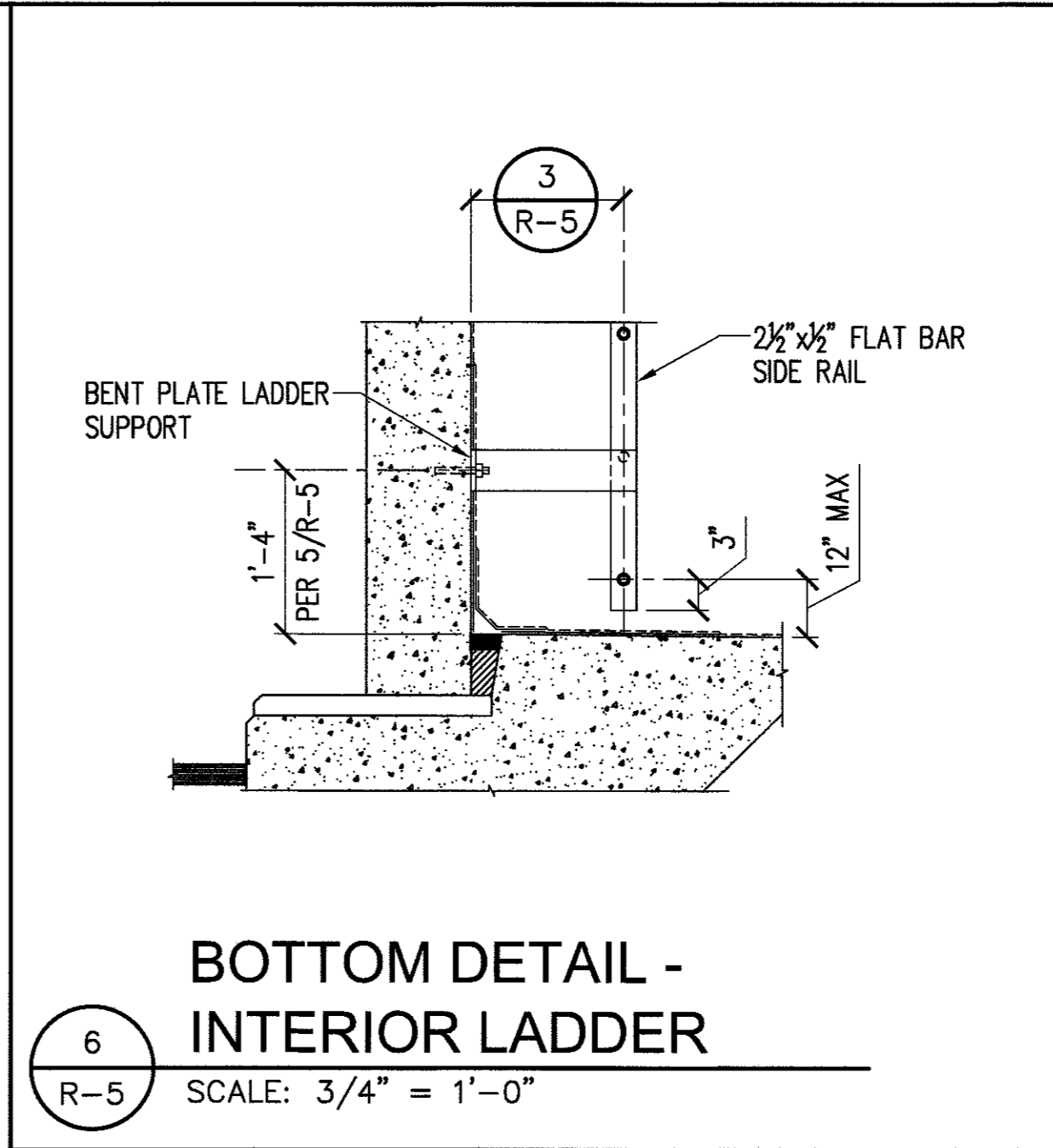
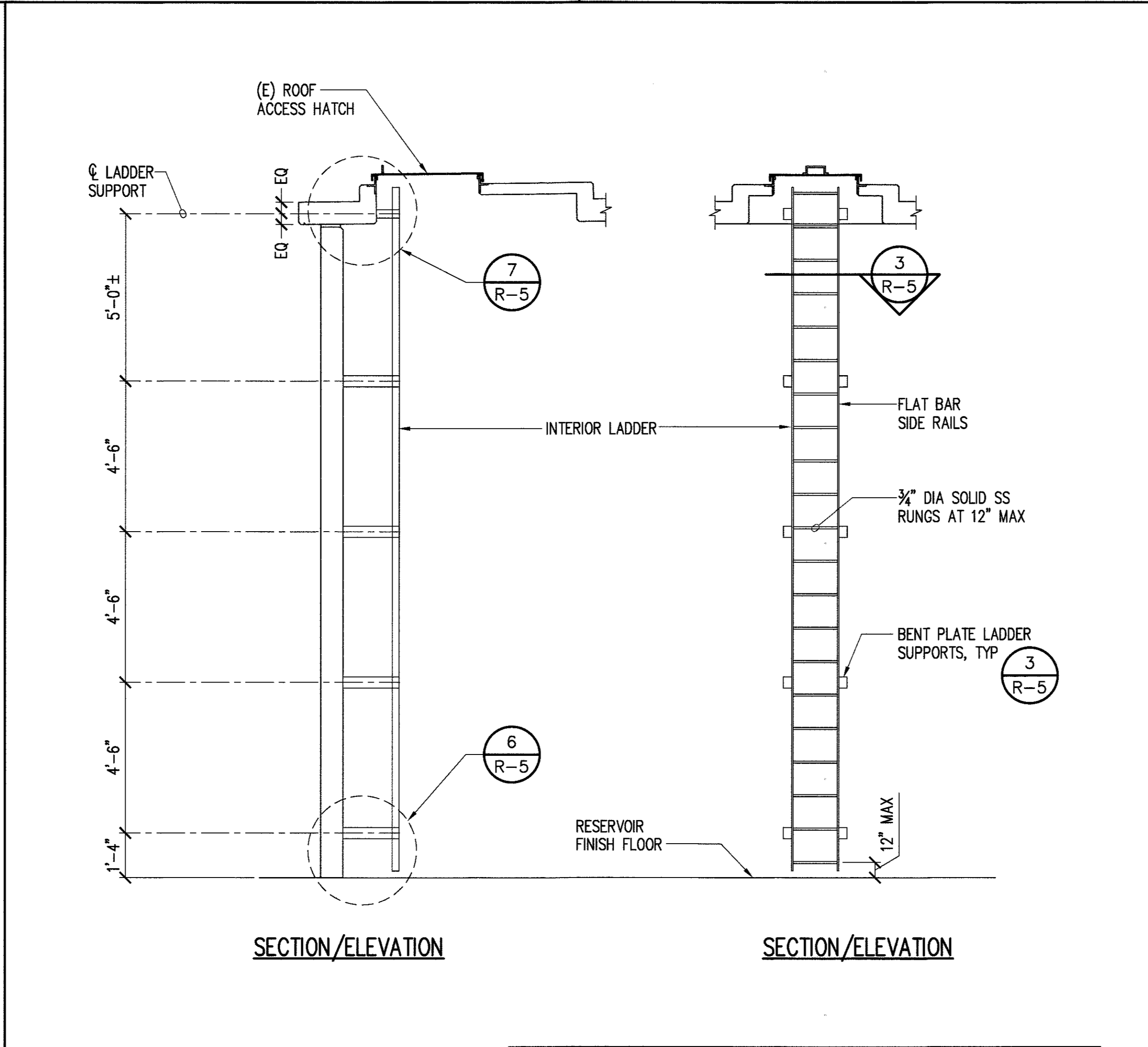
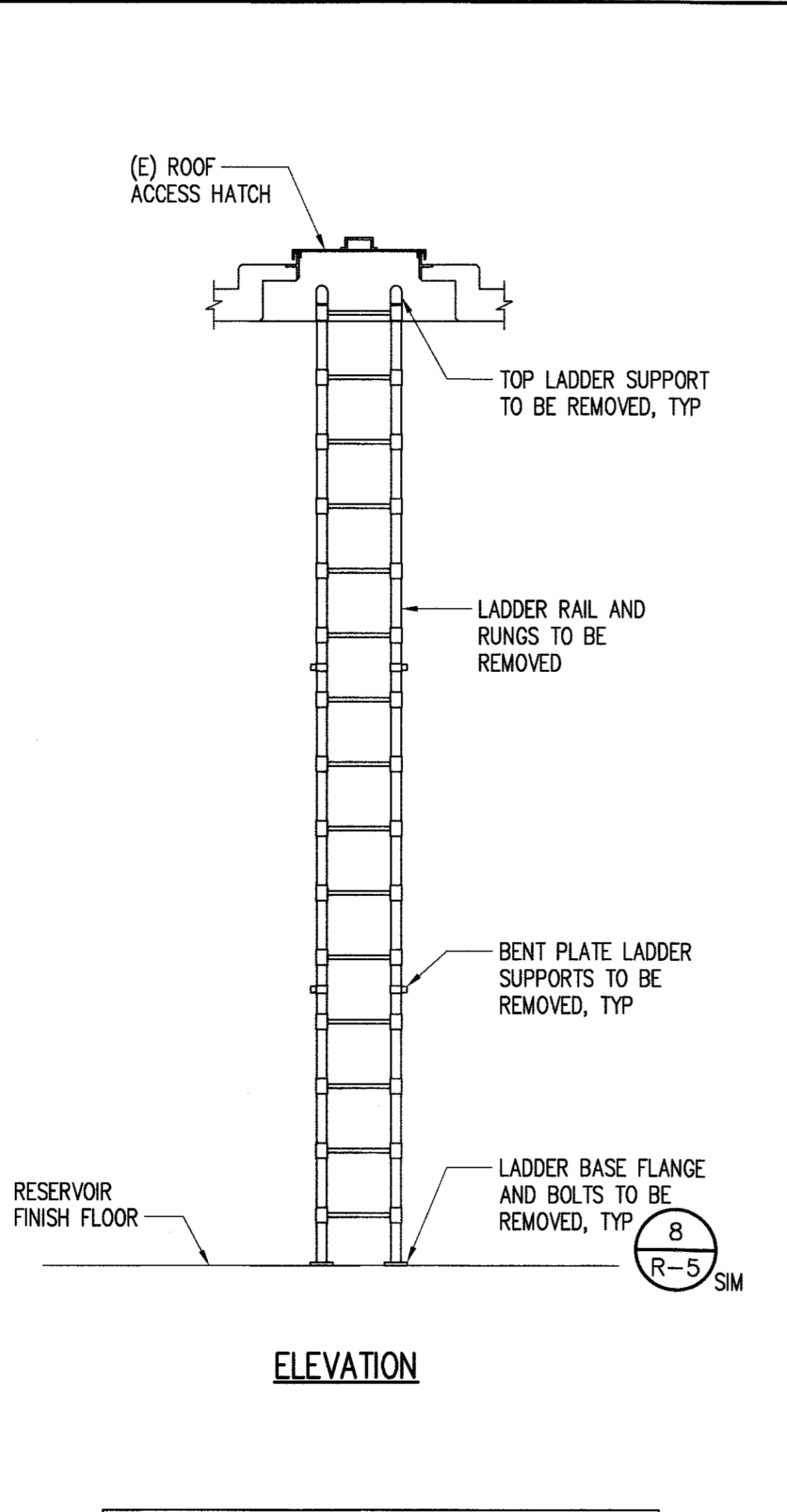
P:\4501-4350\4339 DWS - Rehabilitate Paua Valley Tank #1 - 0.5 MG Concrete, Kekaha\004 Drawings\Structural\AutoCAD\formax\2019-01-09\_4339 DWS Paua\4339\_R-4.dwg, 1/10/2019 3:47:54 PM, dyokomizo



1 RESERVOIR WATER DISCHARGE SCHEMATIC PLAN  
R-5 NOT TO SCALE

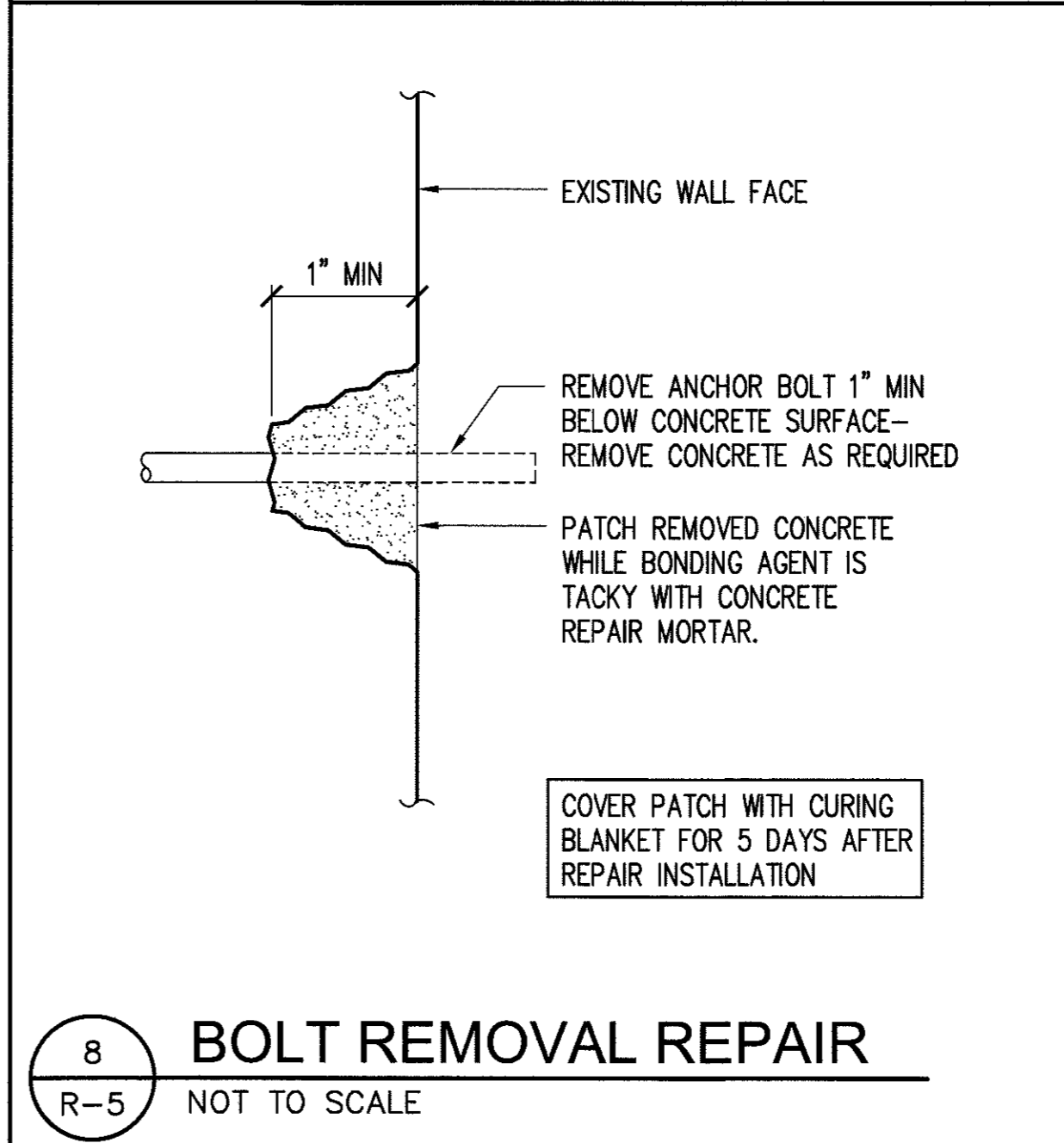
2 SCHEMATIC SECTION  
R-5 NOT TO SCALE

3 INTERIOR LADDER CONNECTION  
R-5 SCALE: 1 1/2" = 1'-0"



4 INTERIOR LADDER DEMOLITION  
R-5 SCALE: 3/8" = 1'-0"

5 INTERIOR LADDER  
R-5 SCALE: 3/8" = 1'-0"



6 BOTTOM DETAIL - INTERIOR LADDER  
R-5 SCALE: 3/4" = 1'-0"

7 TOP CONNECTION - INTERIOR LADDER  
R-5 SCALE: 3/4" = 1'-0"

8 BOLT REMOVAL REPAIR  
R-5 NOT TO SCALE

REVISION	DATE	DESCRIPTION	BY	APPROVED
<b>REHABILITATE PAUA VALLEY TANK #1</b>				
RESERVOIR WATER DISCHARGE SCHEMATIC PLAN AND SECTION, INTERIOR LADDER DETAILS				
APPROVED: <i>[Signature]</i> 1/18/19 MANAGER & CHIEF ENGINEER, DEPT. OF WATER, COUNTY OF KAUAI				
This work was prepared by me or under my supervision and construction to this project will be under my observation.				
Expiration Date of License 04-30-20				
KAI HAWAII, INC. HONOLULU, OAHU, HAWAII, 96813				
DRAWING NO. R-5				
DESIGNED BY: DY DRAWN BY: CAD DATE: 1-09-19 SHEET 8 OF 8 SHEETS				

P:\4301-4350\4339 DWS - Rehabilitate Paua Valley Tank #1, 0.5 MG Concrete, Kekaha\004 Drawings\Structural\AutoCAD\_Format\2019-01-09\_4339 DWS Paua\4339 R-5.dwg, 1/10/2019 3:48:33 PM, dyokomizo



## TRANSMITTAL REQUIREMENTS AND CERTIFICATION STATEMENT FOR E-PERMITTING NOTICE OF INTENT (NOI) SUBMISSIONS

### 1. Submission and File Numbers

e-Permitting Submission #: HNH-RE2M-VNM3V, version 2

I am submitting a (check only one):

Initial NOI.

Revised NOI, File Number: \_\_\_\_\_

NOI for an Already Issued NGPC, Current NGPC File Number: \_\_\_\_\_

### 2. Certification Statement

**I certify under penalty of law that this document and all attachments were prepared under my direction or supervision in accordance with a system designed to assure that qualified personnel properly gather and evaluate the information submitted. Based on my inquiry of the person or persons who manage the system, or those persons directly responsible for gathering the information, the information submitted is, to the best of my knowledge and belief, true, accurate, and complete. I am aware that there are significant penalties for submitting false information, including the possibility of fine and imprisonment for knowing violations.**

Signature \_\_\_\_\_ Date Signed \_\_\_\_\_

Printed First and Last Name \_\_\_\_\_

### 3. Transmittal Requirements (Check all.)

I have read the instructions on Pages 2 and 3.

If I do not follow all of the instructions on Pages 2 and 3, I acknowledge that:

a. This submittal will not be accepted by the Clean Water Branch (CWB);

b. Processing of my NOI will not begin;

c. I am delaying the processing of my NOI; and

d. The CWB may deny my request for NPDES general permit coverage with or without prejudice.

The signature provided in Item No. 2 is an original signature.

My CD or DVD is attached. This CD or DVD contains only the downloaded e-Permitting submission identified in Item No. 1 above. I have not altered this file.

### 4. Filing Fee (Check the applicable box.)

A \$500 check made payable to the State of Hawaii is attached.

The filing fee was paid online through the e-Permitting Portal.

I am submitting a Revised NOI. My filing fee has already been paid under the initial submittal.

I am a State agency, and I am requesting a Bill for Collection.

## **IMPORTANT INSTRUCTIONS:**

You are required to follow these instructions to complete your e-Permitting NOI submittal. Failure to follow all of these instructions will delay the processing of your submittal and may result in the denial of your request for NPDES general permit coverage. **Processing of your submission will not begin until the Clean Water Branch (CWB) receives all of the items below.**

### Item No. 1 – Submission and File Numbers

- a. Enter your e-Permitting Submission #. You may find your unique e-Permitting Submission # (e.g. 15H-ZGVV-421H) in your History Link of the e-Permitting Portal. If you are submitting a revised NOI, the e-Permitting Submission # will contain the version (e.g. 15H-ZGVV-421H, v1).
- b. Check only one (1) box to indicate if you are submitting an Initial NOI (new submittal) or a Revised NOI (revised submittal to address CWB comments) or a NOI for an Already Issued NGPC (see Item No. 1.d below).
- c. Enter your file number if you are revising an Initial NOI to respond to CWB comments. The CWB comments will contain the file number. You will not need to provide a file number if you are submitting an Initial NOI.
- d. Enter your current NGPC file number if you are submitting a NOI for an Already Issued NGPC. A NOI for an Already Issued NGPC is required if there are any changes to the information previously provided. NGPCs can no longer be modified and reissued. Once the NGPC is issued, any changes to the information provided during the NOI processing (except changes to BMPs) will require another NOI with filing fee and another NGPC to be issued. Upon issuance of the NGPC, the existing NGPC will be terminated.

### Item No. 2 – Certification Statement

- a. This is the certification statement for the e-Permitting submission # identified in Item No. 1.
- b. Enter the Printed First and Last Name.
  - i. For an Initial NOI and a NOI for an Already Issued NGPC, the Printed First and Last Name must be the Certifying Person identified in Section No. 2 of the e-Permitting NOI form.
  - ii. For Revised NOI submittals, the Printed First and Last Name may be either the Certifying Person identified in Section No. 2 of the e-Permitting NOI form or the duly authorized representative identified in Section No. 8 of the e-Permitting NOI form.
- c. Enter the Date Signed.
- d. Provide an original Certification signature (hard copy of this form).  
Someone else may sign “for” the individual listed in the Printed First and Last Name.

### Item No. 3 – Transmittal Requirements

- a. You are required to check all of the boxes.
- b. Provide a **CD or DVD containing only the e-Permitting submission in PDF or ZIP**. To download the submission, click on the History Link in the e-Permitting Portal (after you submitted the application). Locate your submission and press the view button under the Action column. Then you may either:
  - i. Press the Print button, scan the document, save the document as a PDF, and save the PDF and all your attachments on the CD or DVD; or
  - ii. Press the Print Screen button on your keyboard, paste the image into a text editor (e.g. MS Word), convert the text file as a PDF, and save the PDF and all your attachments on the CD or DVD; or
  - iii. **Press the Download Submission button**. A PDF file will be generated if you have no attachments. **A ZIP file will be created if you have attachments. Save the PDF or ZIP file on the CD or DVD.****Do not add additional files to the CD or DVD. Your CD or DVD shall match your e-Permitting submission #.**

### Item No. 4 – Filing Fee

- a. You are required to check only one (1) of the boxes.
- b. A \$500 filing fee is required for an Initial NOI and a NOI for an Already Issued NGPC.
- c. If you are a State agency, you may request a Bill for Collection.

### Additional

- a. Mail or deliver this form and all attachments to the Department of Health, Clean Water Branch, Hale Ola Building, 2827 Waimano Home Road, Room 225, Pearl City, Hawaii 96782.

DEPARTMENT OF HEALTH  
Amendment and Compilation of Chapter 11-54  
Hawaii Administrative Rules

**NOV 15 2014**

SUMMARY

1. Title amended.
2. §11-54-2 is amended.
3. §11-54-3 is amended.
4. §11-54-4 is amended.
5. §11-54-5.1 is amended.
6. §11-54-6 is amended.
7. §11-54-8 is amended.
8. §11-54-11 is amended.
9. §11-54-12 is amended.
10. §11-54-13 is amended.
11. §11-54-14 is amended.





HAWAII ADMINISTRATIVE RULES

TITLE 11

DEPARTMENT OF HEALTH

CHAPTER 54

WATER QUALITY STANDARDS

- §11-54-1 Definitions
- §11-54-1.1 General policy of water quality antidegradation
- §11-54-2 Classification of State waters
- §11-54-3 Classification of water uses
- §11-54-4 Basic water quality criteria applicable to all waters
- §11-54-5 Uses and specific criteria applicable to inland waters
- §11-54-5.1 Inland water areas to be protected
- §11-54-5.2 Inland water criteria
- §11-54-6 Uses and specific criteria applicable to marine waters
- §11-54-7 Uses and specific criteria applicable to marine bottom types
- §11-54-8 Recreational criteria for all State waters
- §11-54-9 Zones of mixing
- §11-54-9.1 Water quality certification
- §11-54-9.1.01 Water quality certification; contents of certification
- §11-54-9.1.02 Water quality certification; contents of water quality certification application
- §11-54-9.1.03 Water quality certification; notice and hearing
- §11-54-9.1.04 Water quality certification; waiver
- §11-54-9.1.05 Water quality certification; adoption of new water quality standards
- §11-54-9.1.06 Water quality certification; inspection

- of facility or activity before operation
- §11-54-9.1.07 Water quality certification; notification to licensing or permitting agency
  - §11-54-9.1.08 Water quality certification; termination or suspension
  - §11-54-9.1.09 Water quality certification; review and advice
  - §11-54-10 Water quality analyses
  - §11-54-11 Schedule of compliance
  - §11-54-12 Intake credits
  - §11-54-13 Revision
  - §11-54-14 Severability
  - §11-54-15 Field citations; non-compliance

§11-54-1 Definitions. As used in this chapter:

"Ambient conditions" means the water quality conditions that would occur in the receiving waters if these waters were not influenced by the proposed new human activity.

"Amphidromous" means aquatic life that migrate to and from the sea, but not specifically for reproductive purposes. Amphidromous aquatic life in Hawaiian streams are confined to fresh waters as adults, but their larval stages are partially or entirely spent in the ocean as part of the zooplankton.

"Anchialine pools" means coastal bodies of standing waters that have no surface connections to the ocean but display both tidal fluctuations and salinity ranges characteristic of fresh and brackish waters, indicating the presence of subsurface connections to the watertable and ocean. Anchialine pools are located in porous substrata (recent lava or limestone) and often contain a distinctive assemblage of native aquatic life. Deeper anchialine pools may display salinity stratification, and some shallow

pools may contain standing water only on the highest tides.

"Aquatic life" means "any type or species of mammal, fish, amphibian, reptile, mollusk, crustacean, arthropod, invertebrate, coral, or other animal that inhabits the freshwater or marine environment and includes any part, product, egg, or offspring thereof; or freshwater or marine plants, including, seeds, roots, products, and other parts thereof" (section 187A-1, HRS).

"Best degree of treatment or control" means that treatment or control which is required by applicable statutes and regulations of the State of Hawai'i and the Federal Water Pollution Control Act, as amended, (33 U.S.C. §1251, et seq.) or which is otherwise specified by the director considering technology or management practices currently available in relation to the public interest.

"Best management practices" or "BMPs" means schedules of activities, prohibitions or designations of practices, maintenance procedures, and other management practices to prevent or reduce the pollution of State waters. Best management practices also include treatment requirements, operating procedures, and practices to control plant site runoff, spillage or leaks, sludge or waste disposal, or drainage from raw material storage. BMPs include methods, measures or practices selected by the department to meet nonpoint source pollution control needs. BMPs also include but are not limited to structural and nonstructural controls. BMPs can be applied before, during, and after pollution-producing activities to reduce or eliminate the introduction of pollutants into receiving State waters.

"Brackish waters" means waters with dissolved inorganic ion concentrations (salinity) greater than 0.5 parts per thousand, but less than thirty-two parts per thousand.

"Coastal waters" means "all waters surrounding the islands of the State from the coast of any island to a point three miles seaward from the coast, and, in

the case of streams, rivers, and drainage ditches, to a point three miles seaward from their point of discharge into the sea and includes those brackish waters, fresh waters and salt waters that are subject to the ebb and flow of the tide" (section 342D-1, HRS).

"Coastal wetlands" means natural or man-made ponds and marshes having variable salinity, basin limits, and permanence. These wetlands usually adjoin the coastline and may be subject to tidal, seasonal, or perennial flooding. Coastal wetlands are generally maintained by surface and subterranean sources of fresh and salt water. Many natural coastal wetlands have been modified significantly by man and are characterized by introduced aquatic life. Coastal wetlands include, but are not limited to, salt marshes, open ponds, mudflats, man-made or natural waterbird refuges, isolated seasonal lakes and mangrove flats.

"Department" means department of health, State of Hawai'i.

"Developed estuaries" means volumes of brackish coastal waters in well-defined basins constructed by man or otherwise highly modified from their natural state. Developed estuaries include, but are not limited to, dredged and revetted stream termini.

"Director" means the director of health, State of Hawai'i, or the director's duly authorized agent.

"Discharge" means the discharge of a water pollutant.

"Ditches and flumes" means fresh waters flowing continuously in artificial channels. They are used mainly for the purpose of irrigation and usually receive water from stream diversions. Ditches and flumes may be inflowing (carry water to reservoirs or user areas) or outflowing (drain water from reservoirs or user areas).

"Drainage basin" or "watershed" means the region or area drained by a stream or river system.

"Drainage ditch" means that facility used to carry storm runoff only, not sanitary sewage.

"Elevated wetlands" means natural freshwater wetlands located above 100 m (330 ft) elevation. They are generally found in undisturbed areas, mainly in remote uplands and forest reserves with high rainfall. Elevated wetlands include upland bogs, marshes, swamps, and associated ponds and pools.

"Estuaries" means characteristically brackish coastal waters in well-defined basins with a continuous or seasonal surface connection to the ocean that allows entry of marine fauna. Estuaries may be either natural or developed.

"Existing uses" means those uses actually attained in the water body on or after November 28, 1975 whether or not they are included in the water quality standards.

"Flowing springs and seeps" means perennial, relatively constant fresh water flows not in distinct channels, in which the water emanates from elevated aquifers as wet films or trickles over rock surfaces. They are found typically as natural occurrences along rock faces or banks of deeply incised streams, and artificially along road cuts.

"Flowing waters" means fresh waters flowing unidirectionally down altitudinal gradients. These waters may or may not be confined in distinct channels. Flowing waters include streams, flowing springs and seeps and ditches and flumes.

"Fresh waters" means all waters with a dissolved inorganic ion concentration of less than 0.5 parts per thousand.

"Hydric soil" means soil that, in its undrained condition, is saturated, flooded, or ponded and develops conditions that favor the growth and regeneration of hydrophytic vegetation.

"Hydrophytic vegetation" or "hydrophytes" means plants adapted to growing in seasonally or permanently flooded conditions.

"Intermittent streams" means fresh waters flowing in definite natural channels only during part of the year or season. Intermittent streams include many tributaries of perennial streams.

"Introduced aquatic life" means those species of aquatic organisms that are not native to a given area or water body and whose populations were established (deliberately or accidentally) by human activity. "Introduced" organisms are also referred to as "alien" or "exotic".

"Low wetlands" means freshwater wetlands located below 100 m (330 ft) elevation that may be natural or artificial in origin and are usually found near coasts or in valley termini. Low wetlands are maintained by either stream, well, or ditch influent water, or by exposure of the natural water table. Low wetlands include, but are not limited to, natural lowland marshes, riparian wetlands, littoral zones of standing waters (including lakes, reservoirs, ponds and fishponds) and agricultural wetlands such as taro lo'i.

"Native aquatic life" means those species or higher taxa of aquatic organisms that occur naturally in a given area or water body and whose populations were not established as a result of human activity.

"Natural estuaries" means volumes of brackish coastal waters in well-defined basins of natural origin, found mainly at the mouths of streams or rivers. Natural estuaries can be either stream-fed (drowned stream mouths fed by perennial stream runoff) or spring-fed (nearshore basins with subterranean fresh water sources). Stream-fed estuaries serve as important migratory pathways for larval and juvenile amphidromous stream fauna.

"Natural freshwater lakes" means standing water that is always fresh, in well-defined natural basins, with a surface area usually greater than 0.1 ha (0.25 acres), and in which rooted emergent hydrophytes, if present, occupy no more than thirty per cent of the surface area. Natural freshwater lakes in Hawai'i occur at high, intermediate, and low elevations. Lowland freshwater lakes characteristically lack a natural oceanic connection (surface or subsurface) of a magnitude sufficient to cause demonstrable tidal fluctuations.

"Nonpoint source pollution" has the meaning defined in section 342E-1, HRS.

"Perennial streams" means fresh waters flowing year-round in all or part of natural channels, portions of which may be modified by humans. Flow in perennial streams may vary seasonally. Perennial streams may be subdivided into longitudinal zones, based on elevation and gradient:

- (1) Headwater zone (elevation above 800 m (2600 ft) or gradient above 30 per cent or both);
- (2) Mid-zone (elevation between 50-800 m (165-2600 ft), or gradient between 5 and 30 per cent or both); and
- (3) Terminal zone (elevation below 50 m (165 ft) or gradient below 5 per cent or both).

Perennial streams may be either continuous or interrupted. Continuous perennial streams discharge continuously to the ocean in their natural state, and contain water in the entire length of the stream channel year-round. Interrupted perennial streams usually flow perennially in their upper reaches but only seasonally in parts of their middle or lower reaches, due to either downward seepage of surface flow (naturally interrupted) or to man-made water diversions (artificially interrupted).

"Person" has the same meaning as defined in section 342D-1, HRS.

"Point source" has the same meaning as defined in section 11-55-01.

"Pollution" means "water pollution" as defined in section 342D-1, HRS.

"Reservoirs" means standing water that is always fresh, in well-defined artificially created impoundments.

"Saline or salt waters" means waters with dissolved inorganic ion concentrations greater than thirty-two parts per thousand.

"Saline lakes" means standing waters of salinities ranging from brackish to hypersaline, located in well-defined natural basins, and lacking a natural surface connection to the ocean. Saline lakes



may be present as high-island shoreline or near-shoreline features (e.g. Lake Nomilu, Kauai; Salt Lake, Oahu; Lake Kauhako, Molokai) or as low-island closed lagoons (Lake Laysan, Laysan). They are usually, but not always, fed by seawater seepage and may be diluted by rainwater, overland runoff, or ground water, or concentrated by evaporation.

"Schedule of compliance" means a schedule of remedial measures including an enforceable sequence of actions or operations leading to compliance with an effluent limitation, other limitation, prohibition, or standard.

"Springs and seeps" means small, perennial, relatively constant freshwater flow not in distinct channels, such as wet films or trickles over rock surfaces, in which the water emanates from elevated aquifers. Springs and seeps may be either stream associated, occurring in deeply cut valleys and contributing to stream flow; or coastal, occurring on coastal cliffs and usually flowing into the ocean.

"Standing waters" refers to waters of variable size, depth, and salinity, that have little or no flow and that are usually contained in well-defined basins. Standing water bodies include natural freshwater lakes, reservoirs or impoundments, saline lakes, and anchialine pools.

"State waters", as defined by section 342D-1, HRS, means all waters, fresh, brackish, or salt around and within the State, including, but not limited to, coastal waters, streams, rivers, drainage ditches, ponds, reservoirs, canals, ground waters, and lakes; provided that drainage ditches, ponds, and reservoirs required as part of a water pollution control system are excluded. This chapter applies to all State waters, including wetlands, subject to the following exceptions:

- (1) This chapter does not apply to groundwater, except the director may in the director's discretion take appropriate actions when the director believes that the discharge of pollutants to the ground or groundwater has adversely affected, is adversely affecting, or will adversely affect the quality of any State water other than groundwater.
- (2) This chapter does not apply to drainage ditches, flumes, ponds and reservoirs that are required as part of a water pollution control system.
- (3) This chapter does not apply to drainage ditches, flumes, ponds, and reservoirs that are used solely for irrigation and do not overflow into or otherwise adversely affect the quality of any other State waters, unless such ditches, flumes, ponds, and reservoirs are waters of the United States as defined in 40 C.F.R. section 122.2. The State of Hawai'i has those boundaries stated in the Hawai'i Constitution, art. XV, §1.

"Streams" means seasonal or continuous water flowing unidirectionally down altitudinal gradients in all or part of natural or modified channels as a result of either surface water runoff or ground water influx, or both. Streams may be either perennial or intermittent and include all natural or modified watercourses.

"Stream channel" means a natural or modified watercourse with a definite bed and banks which periodically or continuously contains flowing water.

"Stream system" means the aggregate of water features comprising or associated with a stream, including the stream itself and its tributaries, headwaters, ponds, wetlands, and estuary. A stream system is geographically delimited by the boundaries of its drainage basin or watershed.

"Surface water" means both contained surface water (that is, water upon the surface of the earth in well-defined basins created naturally or artificially

including, but not limited to, streams, other watercourses, lakes, and reservoirs) and diffused surface water (that is, water occurring upon the surface of the ground other than in contained basins). Water from natural springs and seeps is surface water when it exits from the spring onto the earth's surface.

"Water pollution control system" means a system designed and constructed specifically for the purpose of collecting, handling, storing, treating, or disposing of storm water, domestic wastewater, and/or industrial wastewater, to prevent water pollution.

"Wetlands" means land that is transitional between terrestrial and aquatic ecosystems where the water table is usually at or near the surface or the land is covered by shallow water. A wetland shall have one or more of the following attributes:

- (1) At least periodically the land supports predominantly hydrophytic vegetation;
- (2) The substratum is predominantly undrained hydric soil; or
- (3) The substratum is nonsoil (gravel or rocks) and is at least periodically saturated with water or covered by shallow water.

Wetlands may be fresh, brackish, or saline and generally include swamps, marshes, bogs, and associated ponds and pools, mud flats, isolated seasonal ponds, littoral zones of standing water bodies, and alluvial floodplains. For the purpose of applying for water quality certifications under Clean Water Act Section 401, and for National Pollutant Discharge Elimination System (NPDES) permit purposes, the identification and delineation of wetland boundaries shall be done following the procedures described in the U.S. Army Corps of Engineers' Wetlands Delineation Manual (USACE 1987). [Eff 11/12/82; am and comp 10/6/84; am and comp 04/14/88; am and comp 01/18/90; am and comp 10/29/92, am and comp 04/17/00; am and comp 10/02/04; comp 06/15/09; comp 10/21/12; am and comp 12/6/13; am and comp NOV 15 2014 ] (Auth: HRS §187A-1, §§342D-1,

342D-4, 342D-5, Ch. 342E) (Imp: HRS §§342D-4, 342D-5, Ch. 342E; 40 C.F.R. §§ 122.2, 130.2, 131.3, 131.12; 22 U.S.C. §1362(14))

§11-54-1.1 General policy of water quality antidegradation. (a) Existing uses and the level of water quality necessary to protect the existing uses shall be maintained and protected.

(b) Where the quality of the waters exceed levels necessary to support propagation of fish, shellfish, and wildlife and recreation in and on the water, that quality shall be maintained and protected unless the director finds, after full satisfaction of the intergovernmental coordination and public participation provisions of the state's continuing planning process, that allowing lower water quality is necessary to accommodate important economic or social development in the area in which the waters are located. In allowing such degradation or lower water quality, the director shall assure water quality adequate to protect existing uses fully. Further, the director shall assure that there shall be achieved the highest statutory and regulatory requirements for all new and existing point sources and all cost-effective and reasonable best management practices for nonpoint source control.

(c) Where existing high quality waters constitute an outstanding resource, such as waters of national and state parks and wildlife refuges and waters of exceptional recreational or ecological significance, that water quality shall be maintained and protected.

(d) In those areas where potential water quality impairment associated with a thermal discharge is involved, the antidegradation policy and implementing method shall be consistent with section 316 of the Clean Water Act. [Eff 11/12/82; am and comp 10/6/84; am and comp 04/14/88; am and comp 01/18/90; am and comp 10/29/92, am and comp 04/17/00; am and comp

10/2/04; comp 06/15/09; comp 10/21/12; am and comp 12/6/13; comp NOV 15 2014 ] (Auth: HRS §§342D-1, 342D-4, 342D-5, Ch. 342E; 40 C.F.R. §131.12) (Imp: HRS §§342D-4, 342D-5, Ch. 342E)

§11-54-2 Classification of State waters. (a) State waters are classified as either inland waters or marine waters.

- (b) Inland waters may be fresh, brackish, or saline.
- (1) All inland fresh waters are classified as follows, based on their ecological characteristics and other natural criteria:
  - (A) Flowing waters.
    - (i) Streams (perennial and intermittent);
    - (ii) Flowing springs and seeps; and
    - (iii) Ditches and flumes that discharge into any other waters of the State;
  - (B) Standing waters.
    - (i) Natural freshwater lakes; and
    - Reservoirs (impoundments);
  - (C) Wetlands.
    - (i) Elevated wetlands (bogs, marshes, swamps, and associated ponds); and
    - (ii) Low wetlands (marshes, swamps, and associated ponds).
- (2) All inland brackish or saline waters are classified as follows, based on their ecological characteristics and other natural criteria:
  - (A) Standing waters.
    - (i) Anchialine pools; and
    - (ii) Saline lakes.
  - (B) Wetlands.
    - (i) Coastal wetlands (marshes, swamps, and associated ponds).

- (C) Estuaries.
  - (i) Natural estuaries (stream-fed estuaries and spring-fed estuaries); and
  - (ii) Developed estuaries.
- (c) Marine waters
  - (1) All marine waters are either embayments, open coastal, or oceanic waters;
  - (2) All marine waters which are embayments or open coastal waters are also classified according to the following bottom subtypes:
    - (A) Sand beaches;
    - (B) Lava rock shorelines and solution benches;
    - (C) Marine pools and protected coves;
    - (D) Artificial basins;
    - (E) Reef flats; and
    - (F) Soft bottoms. [Eff 11/12/82; am and comp 10/6/84; am and comp 04/14/88; am and comp 01/18/90; am and comp 10/29/92, am and comp 04/17/00; am and comp 10/2/04; comp 06/15/09; comp 10/21/12; am and comp 12/6/13; am and comp **NOV 15 2014** ] (Auth: HRS §§342D-1, 342D-4, 342D-5, Ch. 342E) (Imp: HRS §§342D-4, 342D-5, Ch. 342E)

§11-54-3 Classification of water uses. (a) The following use categories classify inland and marine waters for purposes of applying the standards set forth in this chapter, and for the selection or definition of appropriate quality parameters and uses to be protected in these waters. Storm water discharge into State waters shall be allowed provided it meets the requirements specified in this section and the basic water quality criteria specified in section 11-54-4.

(b) Inland waters.

(1) Class 1.

It is the objective of class 1 waters that these waters remain in their natural state as nearly as possible with an absolute minimum of pollution from any human-caused source. To the extent possible, the wilderness character of these areas shall be protected. Waste discharge into these waters is prohibited, except as provided in section 11-54-4(e). Any conduct which results in a demonstrable increase in levels of point or nonpoint source contamination in class 1 waters is prohibited.

(A) Class 1.a.

The uses to be protected in class 1.a waters are scientific and educational purposes, protection of native breeding stock, baseline references from which human-caused changes can be measured, compatible recreation, aesthetic enjoyment, and other nondegrading uses which are compatible with the protection of the ecosystems associated with waters of this class;

(B) Class 1.b.

The uses to be protected in class 1.b waters are domestic water supplies, food processing, protection of native breeding stock, the support and propagation of aquatic life, baseline references from which human-caused changes can be measured, scientific and educational purposes, compatible recreation, and aesthetic enjoyment. Public access to these waters may be restricted to protect drinking water supplies;

(2) Class 2

The objective of class 2 waters is to protect their use for recreational purposes, the support and propagation of aquatic life,

agricultural and industrial water supplies, shipping, and navigation. The uses to be protected in this class of waters are all uses compatible with the protection and propagation of fish, shellfish, and wildlife, and with recreation in and on these waters. These waters shall not act as receiving waters for any discharge which has not received the best degree of treatment or control compatible with the criteria established for this class. No new treated sewage discharges shall be permitted within estuaries. No new industrial discharges shall be permitted within estuaries, with the exception of:

- (A) Acceptable non-contact thermal and drydock or marine railway discharges within Pearl Harbor, Oahu;
  - (B) Storm water discharges associated with industrial activities (defined in 40 C.F.R. sections 122.26(b)(14) and (b)(15), except (b)(15)(i)(A) and (b)(15)(i)(B)) which meet, at the minimum, the basic water quality criteria applicable to all waters as specified in section 11-54-4(a), and all applicable requirements specified in chapter 11-55, titled "Water Pollution Control"; and
  - (C) Discharges covered by a National Pollutant Discharge Elimination System (NPDES) general permit, approved by the U.S. Environmental Protection Agency and issued by the Department in accordance with 40 C.F.R. section 122.28 and all applicable requirements specified in chapter 11-55, titled "Water Pollution Control".
- (c) Marine waters.  
(1) Class AA.



It is the objective of class AA waters that these waters remain in their natural pristine state as nearly as possible with an absolute minimum of pollution or alteration of water quality from any human-caused source or actions. To the extent practicable, the wilderness character of these areas shall be protected. No zones of mixing shall be permitted in this class:

- (A) Within a defined reef area, in waters of a depth less than 18 meters (ten fathoms); or
- (B) In waters up to a distance of 300 meters (one thousand feet) off shore if there is no defined reef area and if the depth is greater than 18 meters (ten fathoms).

The uses to be protected in this class of waters are oceanographic research, the support and propagation of shellfish and other marine life, conservation of coral reefs and wilderness areas, compatible recreation, and aesthetic enjoyment. The classification of any water area as Class AA shall not preclude other uses of the waters compatible with these objectives and in conformance with the criteria applicable to them;

(2) Class A.

It is the objective of class A waters that their use for recreational purposes and aesthetic enjoyment be protected. Any other use shall be permitted as long as it is compatible with the protection and propagation of fish, shellfish, and wildlife, and with recreation in and on these waters. These waters shall not act as receiving waters for any discharge which has not received the best degree of treatment or control compatible with the criteria established for this class. No new sewage

discharges will be permitted within embayments. No new industrial discharges shall be permitted within embayments, with the exception of:

- (A) Acceptable non-contact thermal and drydock or marine railway discharges, in the following water bodies:
    - (i) Honolulu Harbor, Oahu;
    - (ii) Barbers Point Harbor, Oahu;
    - (iii) Keehi Lagoon Marina Area, Oahu;
    - (iv) Ala Wai Boat Harbor, Oahu; and
    - (v) Kahului Harbor, Maui.
  - (B) Storm water discharges associated with industrial activities (defined in 40 C.F.R. sections 122.26(b)(14) and (b)(15), except (b)(15)(i)(A) and (b)(15)(i)(B)) which meet, at the minimum, the basic water quality criteria applicable to all waters as specified in section 11-54-4, and all applicable requirements specified in the chapter 11-55, titled "Water Pollution Control"; and
  - (C) Discharges covered by a NPDES general permit, approved by the U.S. Environmental Protection Agency and issued by the Department in accordance with 40 C.F.R. section 122.28 and all applicable requirements specified in chapter 11-55, titled "Water Pollution Control".
- (d) Marine bottom ecosystems.
- (1) Class I.
- It is the objective of class I marine bottom ecosystems that they remain as nearly as possible in their natural pristine state with an absolute minimum of pollution from any human-induced source. Uses of marine bottom ecosystems in this class are passive human uses without intervention or alteration, allowing the perpetuation and

preservation of the marine bottom in a most natural state, such as for nonconsumptive scientific research (demonstration, observation or monitoring only), nonconsumptive education, aesthetic enjoyment, passive activities, and preservation;

(2) Class II.

It is the objective of class II marine bottom ecosystems that their use for protection including propagation of fish, shellfish, and wildlife, and for recreational purposes not be limited in any way. The uses to be protected in this class of marine bottom ecosystems are all uses compatible with the protection and propagation of fish, shellfish, and wildlife, and with recreation. Any action which may permanently or completely modify, alter, consume, or degrade marine bottoms, such as structural flood control channelization(dams); landfill and reclamation; navigational structures (harbors, ramps); structural shore protection (seawalls, revetments); and wastewater effluent outfall structures may be allowed upon securing approval in writing from the director, considering the environmental impact and the public interest pursuant to sections 342D-4, 342D-5, 342D-6, and 342D-50, HRS in accordance with the applicable provisions of chapter 91, HRS. [Eff 11/12/82; am and comp 10/6/84; am and comp 04/14/88; am and comp 01/18/90; am and comp 10/29/92, am and comp 04/17/00; am and comp 10/2/04; comp 06/15/09; am and comp 10/21/12; am and comp 12/6/13; am and comp **NOV 15 2014** ](Auth: HRS §174C, §§342D-1, 342D-4, 342D-5, Ch. 342E) (Imp: HRS §§342D-4, 342D-5, Ch. 342E)

§11-54-4 Basic water quality criteria applicable to all waters. (a) All waters shall be free of substances attributable to domestic, industrial, or other controllable sources of pollutants, including:

- (1) Materials that will settle to form objectionable sludge or bottom deposits;
- (2) Floating debris, oil, grease, scum, or other floating materials;
- (3) Substances in amounts sufficient to produce taste in the water or detectable off-flavor in the flesh of fish, or in amounts sufficient to produce objectionable color, turbidity or other conditions in the receiving waters;
- (4) High or low temperatures, biocides, pathogenic organisms, toxic, radioactive, corrosive, or other deleterious substances at levels or in combinations sufficient to be toxic or harmful to human, animal, plant, or aquatic life, or in amounts sufficient to interfere with any beneficial use of the water;
- (5) Substances or conditions or combinations thereof in concentrations which produce undesirable aquatic life; and
- (6) Soil particles resulting from erosion on land involved in earthwork, such as the construction of public works; highways; subdivisions; recreational, commercial, or industrial developments; or the cultivation and management of agricultural lands.

(b) The director is authorized to impose by order the penalties and fines and corrective measures as specified in chapters 342D and 342E, HRS, against any person who discharges or otherwise causes or allows water pollutants to enter State waters and cause violation of this chapter, unless that person acted in compliance with a permit or variance issued by the director pursuant to chapters 342D, HRS, for

that person's discharges. Each day that the person has caused each water quality standard not to be met shall constitute a separate offense.

(c) To ensure compliance with paragraph (a)(4), all State waters are subject to monitoring and to the following standards for acute and chronic toxicity and the protection of human health.

(1) As used in this section:

"Acute Toxicity" means the degree to which a pollutant, discharge, or water sample causes a rapid adverse impact to aquatic organisms. The acute toxicity of a discharge or receiving water is measured using the methods in section 11-54-10, unless other methods are specified by the director.

"Chronic Toxicity" means the degree to which a pollutant, discharge, or water sample causes a long-term adverse impact to aquatic organisms, such as a reduction in growth or reproduction. The chronic toxicity of a discharge or receiving water is measured using the methods in section 11-54-10, unless other methods are specified by the director.

"Dilution" means, for discharges through submerged outfalls, the average and minimum values calculated using the models in the EPA publication, Initial Mixing Characteristics of Municipal Ocean Discharges (EPA/600/3-85/073, November, 1985), or in the EPA publication, Expert System for Hydrodynamic Mixing Zone Analysis of Conventional and Toxic Submerged Single Port Discharges (Cormix 1) (EPA/600/3-90/012), February, 1990.

"In-Stream Waste Concentration" (IWC) means the concentration of a toxicant in the receiving water, or for a discharge, the concentration of the effluent after minimum dilution authorized by the department. A discharge of one hundred divided by the minimum dilution is the IWC when the dilution is authorized by the director. A discharge of one hundred per cent effluent is the

IWC when dilution is not authorized by the director.

"No Observed Effect Concentration" (NOEC), means the highest per cent concentration of a discharge or water sample, in dilution water, which causes no observable adverse effect in a chronic toxicity test. For example, an NOEC of 100 per cent indicates that an undiluted discharge or water sample causes no observable adverse effect to the organisms in a chronic toxicity test.

"Test of Significant Toxicity" (TST) means the alternative statistical method for analyzing and interpreting valid whole effluent toxicity test data as described in the EPA publications, National Pollutant Discharge Elimination System Test of Significant Toxicity Implementation Document, EPA 833-R-10-003 (June 2010), and National Pollutant Discharge Elimination System Test of Significant Toxicity Technical Document, EPA 833-R-10-004 (June 2010).

(2) Narrative toxicity and human health standards.

(A) Acute Toxicity Standards: All State waters shall be free from pollutants in concentrations which exceed the acute standards listed in paragraph (3). All State waters shall also be free from acute toxicity as measured using the toxicity tests listed in section 11-54-10, or other methods specified by the director.

(B) Chronic Toxicity Standards: All State waters shall be free from pollutants in concentrations which on average during any twenty-four hour period exceed the chronic standards listed in paragraph (3). All State waters shall also be free from chronic toxicity as measured using the toxicity tests listed in section 11-54-10, or other methods specified by the director.

- (C) Human Health Standards: All State waters shall be free from pollutants in concentrations which, on average during any thirty day period, exceed the "fish consumption" standards for non-carcinogens in paragraph (3). All State waters shall also be free from pollutants in concentrations, which on average during any 12 month period, exceed the "fish consumption" standards for pollutants identified as carcinogens in paragraph (3).
- (3) Numeric standards for toxic pollutants applicable to all waters. The freshwater standards apply where the dissolved inorganic ion concentration is less than 0.5 parts per thousand; saltwater standards apply above 0.5 parts per thousand. Values for metals refer to the dissolved fraction. All values are expressed in micrograms per liter.

<u>Pollutant</u>	<u>Freshwater</u>		<u>Saltwater</u>		<u>Fish Consumption</u>
	<u>Acute</u>	<u>Chronic</u>	<u>Acute</u>	<u>Chronic</u>	
Acenaphthene	570	ns	320	ns	ns
Acrolein	23	ns	18	ns	250
Acrylonitrile*	2,500	ns	ns	ns	0.21
Aldrin*	3.0	ns	1.3	ns	0.000026
Aluminum	750	260	ns	ns	ns
Antimony	3,000	ns	ns	ns	15,000
Arsenic	360	190	69	36	ns
Benzene*	1,800	ns	1,700	ns	13
Benzidine*	800	ns	ns	ns	0.00017
Beryllium*	43	ns	ns	ns	0.038

<u>Pollutant</u>	<u>Freshwater</u>		<u>Saltwater</u>		<u>Fish Consumption</u>
	<u>Acute</u>	<u>Chronic</u>	<u>Acute</u>	<u>Chronic</u>	
Cadmium	3+	3+	43	9.3	ns
Carbon tetra- chloride*	12,000	ns	16,000	ns	2.3
Chlordane*	2.4	0.0043	0.09	0.004	0,00016
Chlorine	19	11	13	7.5	ns
Chloroethers- ethyl (bis-2)*	ns	ns	ns	ns	0.44
isopropyl	ns	ns	ns	ns	1,400
methyl (bis)*	ns	ns	ns	ns	0.00060
Chloroform*	9,600	ns	ns	ns	5.1
Chlorophenol (2)	1,400	ns	ns	ns	ns
Chlorpyrifos	0,083	0.041	0.011	0.0056	ns
Chromium (VI)	16	11	1,100	50	ns
Copper	6+	6+	2.9	2.9	ns
Cyanide	22	5.2	1	1	ns
DDT*	1.1	0.001	0.013	0.001	0.000008
metabolite TDE*	0.03	ns	1.2	ns	ns
Demeton	ns	0.1	ns	0.1	ns
Dichloro- benzenes*	370	ns	660	ns	850
benzidine*	ns	ns	ns	ns	0,007
ethane (1,2)*	39,000	ns	38,000	ns	79
phenol (2,4)	670	ns	ns	ns	ns
propanes	7,700	ns	3,400	ns	ns
propene (1,3)	2,000	ns	260	ns	4.6



<u>Pollutant</u>	<u>Freshwater</u>		<u>Saltwater</u>		<u>Fish Consumption</u>
	<u>Acute</u>	<u>Chronic</u>	<u>Acute</u>	<u>Chronic</u>	
Dieldrin*	2,5	0,0019	0,71	0.0019	0.000025
Dinitro					
o-cresol (4,6)	ns	ns	ns	ns	250
toluenes*	110	ns	200	ns	3.0
Dioxin*	0.003	ns	ns	ns	5.0x10 <sup>-9</sup>
Diphenyl-					
hydrazine (1,2)	ns	ns	ns	ns	0.018
Endosulfan	0.22	0.056	0.034	0.0087	52
Endrin	0.18	0.0023	0.037	0.0023	ns
Ethylbenzene	11,000	ns	140	ns	1,070
Fluoranthene	1,300	ns	13	ns	18
Guthion	ns	0.01	ns	0.01	ns
Heptachlor*	0.52	0.0038	0.053	0.0036	0.00009
Hexachloro-					
benzene*	ns	ns	ns	ns	0.00024
butadiene*	30	ns	11	ns	16
cyclohexane-					
alpha*	ns	ns	ns	ns	0.010
beta*	ns	ns	ns	ns	0.018
technical*	ns	ns	ns	ns	0.014
cyclopentadiene	2	ns	2	ns	ns
ethane*	330	ns	310	ns	2.9
Isophorone	39,000	ns	4,300	ns	170,000
Lead	29+	29+	140	5.6	ns
Lindane*	2.0	0.08	0.16	ns	0.020

<u>Pollutant</u>	<u>Freshwater</u>		<u>Saltwater</u>		<u>Fish Consumption</u>
	<u>Acute</u>	<u>Chronic</u>	<u>Acute</u>	<u>Chronic</u>	
Malathion	ns	0.1	ns	0.1	ns
Mercury	2.4	0.55	2.1	0.025	0.047
Methoxychlor	ns	0.03	ns	0.03	ns
Mirex	ns	0.001	ns	0.001	ns
Naphthalene	770	ns	780	ns	ns
Nickel	5+	5+	75	8.3	33
Nitrobenzene	9,000	ns	2,200	ns	ns
Nitrophenols*	77	ns	1,600	ns	ns
Nitrosamines*	1,950	ns	ns	ns	0.41
Nitroso					
dibutylamine-N*	ns	ns	ns	ns	0.19
diethylamine-N*	ns	ns	ns	ns	0.41
dimethylamine-N*	ns	ns	ns	ns	5.3
diphenylamine-N*	ns	ns	ns	ns	5.3
pyrrolidine-N*	ns	ns	ns	ns	30
Parathion	0.065	0.013	ns	ns	ns
Pentachloro-					
ethanes	2,400	ns	130	ns	ns
benzene	ns	ns	ns	ns	28
phenol	20	13	13	ns	ns
Phenol	3,400	ns	170	ns	ns
2,4-dimethyl	700	ns	ns	ns	ns
Phthalate esters					
dibutyl	ns	ns	ns	ns	50,000
diethyl	ns	ns	ns	ns	590,000

<u>Pollutant</u>	<u>Freshwater</u>		<u>Saltwater</u>		<u>Fish Consumption</u>
	<u>Acute</u>	<u>Chronic</u>	<u>Acute</u>	<u>Chronic</u>	
di-2-ethylhexyl	ns	ns	ns	ns	16,000
dimethyl	ns	ns	ns	ns	950,000
Polychlorinated biphenyls*	2.0	0.014	10	0.03	0.000079
Polynuclear aromatic hydrocarbons*	ns	ns	ns	ns	0.01
Selenium	20	5	300	71	ns
Silver	1+	1+	2.3	ns	ns
Tetrachloro- ethanes	3,100	ns	ns	ns	ns
benzene (1,2,4,5)	ns	ns	ns	ns	16
ethane (1,1,2,2)*	ns	ns	3,000	ns	3.5
ethylene*	1,800	ns	3,400	145	2.9
phenol (2,3,5,6)	ns	ns	ns	440	ns
Thallium	470	ns	710	ns	16
Toluene	5,800	ns	2,100	ns	140,000
Toxaphene*	0.73	0.0002	0.21	0.0002	0.00024
Tributyltin	ns	0.026	ns	0.01	ns
Trichloro- ethane (1,1,1)	6,000	ns	10,400	ns	340,000
ethane (1,1,2)*	6,000	ns	ns	ns	14
ethylene*	15,000	ns	700	ns	26
phenol (2,4,6)*	ns	ns	ns	ns	1.2
Vinyl chloride*	ns	ns	ns	ns	170
Zinc	22+	22+	95	86	ns

ns - No standard has been developed.

- \* - Carcinogen.
  - + - The value listed is the minimum standard. Depending upon the receiving water CaCO<sub>3</sub> hardness, higher standards may be calculated using the respective formula in the U. S. Environmental Protection Agency publication Quality Criteria for Water (EPA 440/5-86-001, Revised May 1, 1987).
- Note - Compounds listed in the plural in the "Pollutant" column represent complex mixtures of isomers.
- Numbers listed to the right of these compounds refer to the total allowable concentration of any combination of isomers of the compound, not only to concentrations of individual isomers.
- (4) The following are basic requirements applicable to discharges to State waters. These standards shall be enforced through effluent limitations or other conditions in discharge permits. The director may apply more stringent discharge requirements to any discharge if necessary to ensure compliance with all standards in paragraph (2).
- (A) Continuous discharges through submerged outfalls.
- (i) The No Observed Effect Concentration (NOEC), expressed as per cent effluent, of continuous discharges through submerged outfalls shall not be less than 100 divided by the minimum dilution; or,
  - (ii) The Test of Significant Toxicity (TST), as described in EPA 833-R-10-003 (June 2010) and EPA 833-R-10-004 (June 2010), shall be used to demonstrate no unacceptable level of chronic toxicity at the In-stream Waste Concentration (IWC). The chronic toxicity criterion is expressed using a regulatory management decision (b value) of 0.75 for chronic toxicity where, a 0.25 effect

- level (or more) at the IWC demonstrates an unacceptable level of chronic toxicity.
- (B) Continuous discharges through submerged outfalls shall not contain:
- (i) Pollutants in twenty-four hour average concentrations greater than the values obtained by multiplying the minimum dilution by the standards in paragraph (3) for the prevention of chronic toxicity.
  - (ii) Non-carcinogenic pollutants in thirty day average concentrations greater than the values obtained by multiplying the minimum dilution by the standards in paragraph (3) for fish consumption.
  - (iii) Carcinogenic pollutants in twelve month average concentrations greater than the values obtained by multiplying the average dilution by the standards in paragraph (3) for fish consumption.
- (C) Discharges without submerged outfalls.
- (i) The survival of test organisms in an undiluted acute toxicity test of any discharge shall not be less than eighty per cent;
  - (ii) Compliance with the acute toxicity NPDES effluent limit is demonstrated by using the Test of Significant Toxicity (TST) as described in EPA 833-R-10-003 (June 2010) and EPA 833-R-10-004 (June 2010). The acute toxicity criterion is expressed using a regulatory management decision (*b* value) of 0.80 for acute toxicity

- test methods listed in 11-54-10, where, in an undiluted acute toxicity test, a 0.20 effect level (or more) at the IWC demonstrates an unacceptable level of acute toxicity; or,
- (iii) The Test of Significant Toxicity (TST), as described in EPA 833-R-10-003 (June 2010) and EPA 833-R-10-004 (June 2010), shall be used to demonstrate no unacceptable level of chronic toxicity at the IWC. The chronic toxicity criterion is expressed using a regulatory management decision (*b* value) of 0.75 for chronic toxicity where, a 0.25 effect level (or more) at the IWC demonstrates an unacceptable level of chronic toxicity. Toxicity is considered significant if the mean response in the IWC is greater than 0.75 multiplied by the mean response of the control.

No discharge shall contain pollutants in concentrations greater than the standards in paragraph (3) for the prevention of acute toxicity to aquatic life. The director may make a limited allowance for dilution for a discharge in this category if it meets the following criteria: the discharge velocity is greater than 3 meters per second; the discharge enters the receiving water horizontally, and; the receiving water depth at the discharge point is greater than zero.

- (d) The requirements of paragraph (a)(6) shall be deemed met upon a showing that the land on which the erosion occurred or is occurring is being managed

in accordance with soil conservation practices acceptable to the applicable soil and water conservation district and the director, and that a comprehensive conservation program is being actively pursued, or that the discharge has received the best degree of treatment or control, and that the severity of impact of the residual soil reaching the receiving body of water is deemed to be acceptable.

(e) In order to reduce a risk to public health or safety arising out of any violation or probable violation of this chapter, the director may post or order posted any State waters. Posting is the placement, erection, or use of a sign or signs warning people to stay out of, avoid drinking, avoid contact with, or avoid using the water. This posting authority shall not limit the director's authority to post or order posting in any other appropriate case or to take any enforcement action.

(f) Pesticide Application.

(1) As used in this section:

"Declared pest emergency situation" means an event defined by a public declaration by the President of the United States, state governor or, with the concurrence of the director, county mayor of a pest problem determined to require control through application of a pesticide beginning less than ten days after identification of the need for pest control.

"Pest" means any insect, rodent, nematode, fungus, weed, or

(A) Any other form of terrestrial or aquatic plant or animal life or virus, bacteria, or other micro-organism (except viruses, bacteria, or other micro-organisms on or in living man or other living animals) which the Administrator declares to be a pest under 7 U.S.C. §136w(c)(1).

"Pesticide" means

(A) Any substance or mixture of substances intended for preventing, destroying,

- repelling, or mitigating any pest;
- (B) Any substance or mixture of substances intended for use as a plant regulator, defoliant, or desiccant; and
  - (C) Any nitrogen stabilizer, except that the term "pesticide" shall not include any article that is a "new animal drug" within the meaning of 21 U.S.C. 321(w), that has been determined by the Secretary of Health and Human Services not to be a new animal drug by a regulation establishing conditions of use for the article, or that is an animal feed within the meaning of 21 U.S.C. 321(x) bearing or containing a new animal drug.

The term "pesticide" does not include liquid chemical sterilant products (including any sterilant or subordinate disinfectant claims on such products) for use on a critical or semi-critical device, as defined in section 201 of 21 U.S.C. §321. For purposes of the preceding sentence, the term "critical device" includes any device which is introduced directly into the human body, either into or in contact with the bloodstream or normally sterile areas of the body and the term "semi-critical device" includes any device which contacts intact mucous membranes but which does not ordinarily penetrate the blood barrier or otherwise enter normally sterile areas of the body. The term "pesticide" applies to insecticides, herbicides, fungicides, rodenticides, and various other substances used to control pests. The definition encompasses all uses of pesticides authorized under the Federal Insecticide, Fungicide, and Rodenticide Act (FIFRA) including uses authorized under sections 3 (registration), 5 (experimental use permits), 18 (emergency exemptions), 24(c) (special local needs registrations), and 25(b) (exemptions from FIFRA).



Note: drugs used to control diseases of humans or animals (such as livestock, fishstock and pets) are not considered pesticides; such drugs are regulated by the Food and Drug Administration. Fertilizers, nutrients, and other substances used to promote plant survival and health are not considered plant growth regulators and thus are not pesticides. Biological control agents, except for certain microorganisms, are exempted from regulation under FIFRA. (Biological control agents include beneficial predators such as birds or ladybugs that eat insect pests, parasitic wasps, fish, etc.).

- (2) Pesticide applications may be made to State waters if the pesticide applications are:
- (A) Registered by the U.S. Environmental Protection Agency and licensed by the state department of agriculture or other state agency regulating pesticides;
  - (B) Used for the purpose of controlling mosquito and other flying insect pests; controlling weed and algae pests; controlling animal pests; controlling forest canopy pests; or protecting public health or the environment in a declared pest emergency situation or as determined by the director;
  - (C) Applied in a manner consistent with the labeling of the pesticide under FIFRA;
  - (D) Applied under permits issued pursuant to HRS chapter 342D, if the director requires such permits under chapter 342D, HRS;
  - (E) Applied in a manner so applicable narrative and numeric state water quality criteria as required in chapter 11-54 are met. [Eff 11/12/82; am and comp 10/6/84; am and comp 04/14/88; am and comp 01/18/90; am and comp 10/29/92, am and comp 04/17/00; am and comp 10/2/04; am and comp 06/15/09; am and comp 10/21/12; am and comp 12/6/13; am and

comp NOV 15 2014 ] (Auth: HRS §§342D-1, 342D-4, 342D-5, Ch. 342E) (Imp: HRS §§342D-4, 342D-5, Ch. 342E)

§11-54-5 Uses and specific criteria applicable to inland waters. Inland water areas to be protected are described in section 11-54-5.1, corresponding specific criteria are set forth in section 11-54-5.2; water body types are defined in section 11-54-1. [Eff 11/12/82; am and comp 10/6/84; am and comp 04/14/88; am and comp 01/18/90; am and comp 10/29/92, am and comp 04/17/00; am and comp 10/2/04; comp 06/15/09; comp 10/21/12; comp 12/6/13; comp NOV 15 2014 ] (Auth: HRS §§342D-1, 342D-4, 342D-5, Ch. 342E) (Imp: HRS §§342D-4, 342D-5, Ch. 342E)

§11-54-5.1 Inland water areas to be protected.

(a) Freshwaters.

(1) Flowing waters: perennial streams and rivers, intermittent streams, springs and seeps, and man-made ditches and flumes that discharge into any other waters of the State.

(A) Class 1.a.:

- (i) All flowing waters within the natural reserves, preserves, sanctuaries, and refuges established by the department of land and natural resources under chapter 195, HRS, or similar reserves for the protection of aquatic life established under chapter 195, HRS.
- (ii) All flowing waters in national and state parks.

- (iii) All flowing waters in state or federal fish and wildlife refuges.
- (iv) All flowing waters which have been identified as a unique or critical habitat for threatened or endangered species by the U.S. Fish and Wildlife Service.
- (v) All flowing waters in Waimanu National Estuarine Research Reserve (Hawai'i).

As listed in Appendix A dated July 1, 2014, entitled "Class 1, Inland Waters", located at the end of this chapter.

- (B) Class 1.b.: All flowing waters in protective subzones designated under chapter 13-5 by the state department of land and natural resources as listed in Appendix A dated July 1, 2014, entitled "Class 1, Inland Waters", located at the end of this chapter.
- (C) Class 2.: All flowing waters in areas not otherwise classified.

All flowing waters in classes 1 and 2 in which water quality exceeds the standards specified in this chapter shall not be lowered in quality unless it has been affirmatively demonstrated to the director that the change is justifiable as a result of important economic or social development and will not interfere with or become injurious to any assigned uses made of, or presently in, those waters. This statement of antidegradation policy does not limit the applicability of the policy in section 11-54-1.1 to the whole chapter.

(2) Standing waters (natural freshwater lakes and reservoirs):

- (A) Class 1.a.:
  - (i) All standing waters within the natural reserves, preserves,

sanctuaries, and refuges established by the department of land and natural resources under chapter 195, HRS, or similar reserves for the protection of aquatic life established under chapter 195, HRS.

- (ii) All standing waters in national and state parks.
- (iii) All standing waters in state or federal fish and wildlife refuges.
- (iv) All standing waters which have been identified as a unique or critical habitat for threatened or endangered species by the U.S. Fish and Wildlife Service.
- (v) All standing waters in Waimanu National Estuarine Research Reserve (Hawai'i).

As listed in Appendix A dated July 1, 2014, entitled "Class 1, Inland Waters", located at the end of this chapter.

- (B) Class 1.b.: All standing waters in protective subzones designated under chapter 13-5 by the state department of land and natural resources as listed in Appendix A dated July 1, 2014, entitled "Class 1, Inland Waters", located at the end of this chapter.
  - (C) Class 2.: All standing waters in areas not otherwise classified.
- (3) Elevated wetlands and low wetlands:
- (A) Class 1.a.:
    - (i) All elevated and low wetlands within the natural reserves, preserves, sanctuaries, and refuges established by the department of land and natural resources under chapter 195, HRS, or similar reserves for the

protection of aquatic life established under chapter 195, HRS.

- (ii) All elevated and low wetlands in national and state parks.
- (iii) All elevated and low wetlands in state or federal fish and wildlife refuges.
- (iv) All elevated and low wetlands which have been identified as a unique or critical habitat for threatened or endangered species by the U.S. Fish and Wildlife Service.
- (v) All elevated and low wetlands in Waimanu National Estuarine Research Reserve (Hawai'i).

As listed in Appendix A dated July 1, 2014, entitled "Class 1, Inland Waters", located at the end of this chapter.

- (B) Class 1.b.: All elevated and low wetlands in protective subzones designated under chapter 13-5 by the state department of land and natural resources as listed in Appendix A dated July 1, 2014, entitled "Class 1, Inland Waters", located at the end of this chapter.
  - (C) Class 2.: All elevated and low wetlands not otherwise classified.
- (b) Brackish or saline waters (anchialine pools, saline lakes, coastal wetlands, and estuaries).
- (1) Class 1.a.:
    - (A) All inland brackish or saline waters within natural reserves, preserves, sanctuaries, and refuges established by the department of land and natural resources under chapter 195, HRS, or similar reserves for the protection of

aquatic life established under chapter 195, HRS.

- (B) All inland brackish or saline waters in national and state parks.
- (C) All inland brackish or saline waters in state or federal fish and wildlife refuges.
- (D) All inland brackish or saline waters which have been identified as a unique or critical habitat for threatened or endangered species by the U.S. Fish and Wildlife Service.
- (E) All inland brackish and saline waters in Waimanu National Estuarine Research Reserve (Hawai'i).
- (F) The following natural estuaries:  
Lumaha'i and Kilauea estuaries  
(Kaua'i).

As listed in Appendix A dated July 1, 2014, entitled "Class 1, Inland Waters", located at the end of this chapter.

- (2) Class 1.b.: All inland brackish or saline waters in protective subzones designated under chapter 13-5 by the state department of land and natural resources as listed in Appendix A dated July 1, 2014, entitled "Class 1, Inland Waters", located at the end of this chapter.
- (3) Class 2.: All inland brackish and saline waters not otherwise classified. [Eff 11/12/82; am and comp 10/6/84; am and comp 04/14/88; am and comp 01/18/90; am and comp 10/29/92, am and comp 04/17/00; am and comp 10/2/04; comp 06/15/09; comp 10/21/12; am and comp 12/6/13; am and comp **NOV 15 2014** ] (Auth: HRS §§342D-1, 342D-4, 342D-5, Ch. 342E) (Imp: HRS §§342D-4, 342D-5, Ch. 342E)

§11-54-5.2 Inland water criteria. (a) Criteria for springs and seeps, ditches and flumes, natural freshwater lakes, reservoirs, low wetlands, coastal wetlands, saline lakes, and anchialine pools. Only the basic criteria set forth in section 11-54-4 apply to springs and seeps, ditches and flumes, natural freshwater lakes, reservoirs, low wetlands, coastal wetlands, saline lakes, and anchialine pools. Natural freshwater lakes, saline lakes, and anchialine pools will be maintained in the natural state through Hawai'i's "no discharge" policy for these waters. Waste discharge into these waters is prohibited, except as provided in section 11-54-4(e) (see section 11-54-3(b)(1)).

(b) Specific criteria for streams. Water column criteria for streams shall be as provided in the following table:

<u>Parameter</u>	Geometric mean not to exceed the <u>given value</u>	Not to exceed the given value more than <u>ten per cent of the time</u>	Not to Exceed the given value more than two per cent of <u>the time</u>
Total Nitrogen (ug N/L)	250.0* 180.0**	520.0* 380.0**	800.0* 600.0**
Nitrate + Nitrite Nitrogen (ug [NO <sub>3</sub> +NO <sub>2</sub> ]-N/L)	70.0* 30.0**	180.0* 90.0**	300.0* 170.0**
Total Phosphorus (ug P/L)	50.0* 30.0**	100.0* 60.0**	150.0* 80.0**
Total Suspended Solids (mg/L)	20.0* 10.0**	50.0* 30.0**	80.0* 55.0**
Turbidity (N.T.U.)	5.0* 2.0**	15.0* 5.5**	25.0* 10.0**

\* Wet season - November 1 through April 30.

\*\* Dry season - May 1 through October 31.

L = liter

N.T.U. = Nephelometric Turbidity Units. A comparison of the intensity of light scattered by the sample under defined conditions with the intensity of light scattered by a standard reference suspension under the same conditions. The higher the intensity of scattered light, the higher the turbidity.

ug = microgram or 0.000001 grams

pH Units - shall not deviate more than 0.5 units from ambient conditions and shall not be lower than 5.5 nor higher than 8.0

Dissolved Oxygen - Not less than eighty per cent saturation, determined as a function of ambient water temperature.

Temperature - Shall not vary more than one degree Celsius from ambient conditions.

Specific Conductance - Not more than three hundred micromhos/centimeter.

(1) Bottom criteria for streams:

- (A) Episodic deposits of flood-borne soil sediment shall not occur in quantities exceeding an equivalent thickness of five millimeters (0.20 inches) over hard bottoms twenty-four hours after a heavy rainstorm.
- (B) Episodic deposits of flood-borne soil sediment shall not occur in quantities exceeding an equivalent thickness of ten millimeters (0.40 inches) over soft bottoms twenty-four hours after a heavy rainstorm.
- (C) In soft bottom material in pool sections of streams, oxidation-reduction potential (EH) in the top ten centimeters (four inches) shall not be less than +100 millivolts.
- (D) In soft bottom material in pool sections of streams, no more than fifty per cent of the grain size distribution of sediment shall be smaller than 0.125 millimeters (0.005 inches) in diameter.



(E) The director shall prescribe the appropriate parameters, measures, and criteria for monitoring stream bottom biological communities including their habitat, which may be affected by proposed actions. Permanent benchmark stations may be required where necessary for monitoring purposes. The water quality criteria for this subsection shall be deemed to be met if time series surveys of benchmark stations indicate no relative changes in the relevant biological communities, as noted by biological community indicators or by indicator organisms which may be applicable to the specific site.

(c) Specific criteria for elevated wetlands: pH units shall not deviate more than 0.5 units from ambient conditions and shall not be lower than 4.5 nor higher than 7.0.

(d) Specific criteria for estuaries.

(1) The following table is applicable to all estuaries except Pearl Harbor:

<u>Parameter</u>	<u>Geometric mean not to exceed the given value</u>	<u>Not to exceed the given value more than ten per cent of the time</u>	<u>Not to Exceed the given value more than two per cent of the time</u>
Total Nitrogen (ug N/L)	200.00	350.00	500.00
Ammonia Nitrogen (ug NH <sub>4</sub> -N/L)	6.00	10.00	20.00
Nitrate + Nitrite Nitrogen (ug [NO <sub>3</sub> +NO <sub>2</sub> ]-N/L)	8.00	25.00	35.00
Total Phosphorus (ug P/L)	25.00	50.00	75.00

<u>Parameter</u>	Geometric mean not to exceed the <u>given value</u>	Not to exceed the given value more than ten per cent <u>of the time</u>	Not to Exceed the given value more than two per cent of <u>the time</u>
Chlorophyll a (ug/L)	2.00	5.00	10.00
Turbidity (N.T.U.)	1.5	3.00	4.00

L = liter

N.T.U. = Nephelometric Turbidity Units. A comparison of the intensity of light scattered by the sample under defined conditions with the intensity of light scattered by a standard reference suspension under the same conditions. The higher the intensity of scattered light, the higher the turbidity.

ug = microgram or 0.000001 grams

pH Units - shall not deviate more than 0.5 units from ambient conditions and shall not be lower than 7.0 nor higher than 8.6.

Dissolved Oxygen - Not less than seventy-five per cent saturation, determined as a function of ambient water temperature and salinity.

Temperature - Shall not vary more than one degree Celsius from ambient conditions.

Salinity - Shall not vary more than ten per cent from ambient conditions.

Oxidation - reduction potential (EH) - Shall not be less than -100 millivolts in the uppermost ten centimeters (four inches) of sediment.

(2) The following table is applicable only to Pearl Harbor Estuary.

§11-54-5.2

<u>Parameter</u>	<u>Geometric mean not to exceed the given value</u>	<u>Not to exceed the given value more than ten per cent of the time</u>	<u>Not to exceed the given value more than two per cent of the time</u>
Total Nitrogen (ug N/L)	300.00	550.00	750.00
Ammonia Nitrogen (ug NH <sub>4</sub> -N/L)	10.00	20.00	30.00
Nitrate + Nitrite Nitrogen (ug [NO <sub>3</sub> +NO <sub>2</sub> ]-N/L)	15.00	40.00	70.00
Total Phosphorus (ug P/L)	60.00	130.00	200.00
Chlorophyll a (ug/L)	3.50	10.00	20.00
Turbidity (N.T.U.)	4.00	8.00	15.00

L = liter

N.T.U. = Nephelometric Turbidity Units. A comparison of the intensity of light scattered by the sample under defined conditions with the intensity of light scattered by a standard reference suspension under the same conditions. The higher the intensity of scattered light, the higher the turbidity.

ug = microgram or 0.000001 grams.

pH Units - shall not deviate more than 0.5 units from ambient conditions and shall not be lower than 6.8 nor higher than 8.8.

Dissolved Oxygen - Not less than sixty per cent saturation, determined as a function of ambient water temperature and salinity.

Temperature - Shall not vary more than one degree Celsius from ambient conditions.

Salinity - Shall not vary more than ten per cent from ambient conditions.

Oxidation - Reduction potential (EH) - Shall not be less than -100 millivolts in the uppermost ten centimeters (four inches) of sediment. [Eff 11/12/82; am and comp 10/6/84; am and comp 04/14/88; am and comp 01/18/90; am and comp 10/29/92, am and comp 04/17/00; am and comp 10/2/04; comp 06/15/09; am and comp 10/21/12; am and comp 12/6/13; comp **NOV 15 2014** ]  
 (Auth: HRS §§342D-1, 342D-4, 342D-5, Ch. 342E) (Imp: HRS §§342D-4, 342D-5, Ch. 342E)

§11-54-6 Uses and specific criteria applicable to marine waters. (a) Embayments.

(1) As used in this subsection:

"Embayments" means land-confined and physically-protected marine waters with restricted openings to open coastal waters, defined by the ratio of total bay volume to the cross-sectional entrance area of seven hundred to one or greater.

"Total bay volume" is measured in cubic meters and "cross-sectional entrance area" is measured in square meters, and both are determined at mean lower low water.

(2) Water areas to be protected.

(A) Class AA.

- (i) Waters are listed in Appendix B dated July 1, 2014, entitled "Class AA, Marine Waters and Embayments", located at the end of this chapter.
- (ii) All embayments in preserves, reserves, sanctuaries, and refuges established by the department of land and natural resources under chapter 195 or chapter 190, HRS, as listed in Appendix B dated July 1, 2014, entitled "Class AA,

Marine Waters and Embayments", located at the end of this chapter, or similar reserves for the protection of marine life established under chapter 190, HRS as listed in Appendix B dated July 1, 2014, entitled "Class AA, Marine Waters and Embayments", located at the end of this chapter.

(iii) All waters in state or federal fish and wildlife refuges and marine sanctuaries as listed in Appendix B dated July 1, 2014, entitled "Class AA, Marine Waters and Embayments", located at the end of this chapter.

(iv) All waters which have been officially identified as a unique or critical habitat for threatened or endangered species by the U.S. Fish and Wildlife Service as listed in Appendix B dated July 1, 2014, entitled "Class AA, Marine Waters and Embayments", located at the end of this chapter.

(B) Class A.  
Waters are listed in Appendix C dated July 1, 2014, entitled "Class A, Marine Waters and Embayments", located at the end of this chapter.

(3) The following criteria are specific for all embayments excluding those described in subsection (d). (Note that criteria for embayments differ based on fresh water inflow.)

<u>Parameter</u>	Geometric mean not to exceed the <u>given value</u>	Not to exceed the given value more than <u>ten per cent of the time</u>	Not to Exceed the given value more than <u>Two per cent of The time</u>
Total Nitrogen (ug N/L)	200.00* 150.00**	350.00* 250.00**	500.00* 350.00**
Ammonia Nitrogen (ug NH <sub>4</sub> -N/L)	6.00* 3.50**	13.00* 8.50**	20.00* 15.00**
Nitrate + Nitrite Nitrogen (ug [NO <sub>3</sub> +NO <sub>2</sub> ]-N/L)	8.00* 5.00**	20.00* 14.00**	35.00* 25.00**
Total Phosphorus (ug P/L)	25.00* 20.00**	50.00* 40.00**	75.00* 60.00**
Chlorophyll a ug/L)	1.50* 0.50**	4.50* 1.50**	8.50* 3.00**
Turbidity (N.T.U.)	1.5* 0.40**	3.00* 1.00**	5.00* 1.50**

\* "Wet" criteria apply when the average fresh water inflow from the land equals or exceeds one per cent of the embayment volume per day.

\*\* "Dry" criteria apply when the average fresh water inflow from the land is less than one per cent of the embayment volume per day.

Applicable to both "wet" and "dry" conditions:

pH Units - shall not deviate more than 0.5 units from a value of 8.1, except at coastal locations where and when freshwater from stream, stormdrain or groundwater discharge may depress the pH to a minimum level of 7.0.

Dissolved Oxygen - Not less than seventy-five per cent saturation, determined as a function of ambient water temperature and salinity.

Temperature - Shall not vary more than one degree Celsius from ambient conditions.

Salinity - Shall not vary more than ten per cent from natural or seasonal changes considering hydrologic input and oceanographic factors.

L = liter

N.T.U. = Nephelometric Turbidity Units. A comparison of the intensity of light scattered by the sample under defined conditions with the intensity of light scattered by a standard reference suspension under the same conditions. The higher the intensity of scattered light, the higher the turbidity.

ug = microgram or 0.000001 grams

(b) Open coastal waters.

(1) As used in this subsection:

"Open coastal waters" means marine waters bounded by the 183 meter or 600 foot (100 fathom) depth contour and the shoreline, excluding bays named in subsection (a).

(2) Water areas to be protected:

(A) Class AA as listed in Appendix D dated July 1, 2014, entitled "Class AA, Open Coastal Waters", located at the end of this chapter.

All open waters in preserves, reserves, sanctuaries, and refuges established by the department of land and natural resources under chapter 195 or chapter 190, HRS as listed in Appendix D dated July 1, 2014, entitled "Class AA, Open Coastal Waters", located at the end of this chapter, or similar reserves for the protection of marine life established under chapter 190, HRS, as amended as listed in Appendix D dated July 1, 2014, entitled "Class AA, Open Coastal Waters", located at the end of this chapter; or in the refuges or sanctuaries established by the U.S. Fish and Wildlife Service or the National Marine Fisheries Service as listed in Appendix D dated July 1, 2014, entitled "Class AA, Open Coastal

Waters", located at the end of this chapter.

- (B) Class A - All other open coastal waters not otherwise specified.
- (3) The following criteria are specific for all open coastal waters, excluding those described in subsection (d). (Note that criteria for open coastal waters differ, based on fresh water discharge.)

<u>Parameter</u>	Geometric mean not to exceed the <u>given value</u>	Not to exceed the given value more than <u>ten per cent of the time</u>	Not to exceed the given value more than <u>two per cent of the time</u>
Total Nitrogen (ug N/L)	150.00* 110.00**	250.00* 180.00**	350.00* 250.00**
Ammonia Nitrogen (ug NH <sub>4</sub> -N/L)	3.50* 2.00**	8.50* 5.00**	15.00* 9.00**
Nitrate + Nitrite Nitrogen (ug [NO <sub>3</sub> +NO <sub>2</sub> ]-N/L)	5.00* 3.50**	14.00* 10.00**	25.00* 20.00**
Total Phosphorus (ug P/L)	20.00* 16.00**	40.00* 30.00**	60.00* 45.00**
Light Extinction Coefficient (k units)	0.20* 0.10**	0.50* 0.30**	0.85* 0.55**
Chlorophyll a (ug/L)	0.30* 0.15**	0.90* 0.50**	1.75* 1.00**
Turbidity (N.T.U.)	0.50* 0.20**	1.25* 0.50**	2.00* 1.00**

\* "Wet" criteria apply when the open coastal waters receive more than three million gallons per day of fresh water discharge per shoreline mile.

\*\* "Dry" criteria apply when the open coastal waters receive less than three million gallons per day of fresh water discharge per shoreline mile.



Applicable to both "wet" and "dry" conditions:

pH Units - shall not deviate more than 0.5 units from a value of 8.1, except at coastal locations where and when freshwater from stream, stormdrain or groundwater discharge may depress the pH to a minimum level of 7.0.

Dissolved Oxygen - Not less than seventy-five per cent saturation, determined as a function of ambient water temperature and salinity.

Temperature - Shall not vary more than one degree Celsius from ambient conditions.

Salinity - Shall not vary more than ten per cent from natural or seasonal changes considering hydrologic input and oceanographic factors.

k units = the ratio of light measured at the water's surface to light measured at a particular depth.

L = liter

Light Extinction Coefficient is only required for dischargers who have obtained a waiver pursuant to section 301(h) of the Federal Water Pollution Control Act of 1972 (33 U.S.C. 1251), as amended, and are required by EPA to monitor it.

N.T.U. = Nephelometric Turbidity Units. A comparison of the intensity of light scattered by the sample under defined conditions with the intensity of light scattered by a standard reference suspension under the same conditions. The higher the intensity of scattered light, the higher the turbidity.

ug = microgram or 0.000001 grams

(c) Oceanic waters.

(1) As used in this subsection: "Oceanic waters" means all other marine waters outside of the 183 meter (600 feet or 100 fathom) depth contour.

(2) Water areas to be protected: Class A - All oceanic waters.

(3) The following criteria are specific for oceanic waters:

<u>Parameter</u>	Geometric mean not to exceed the <u>given value</u>	Not to exceed The given value more than ten per cent <u>of the time</u>	Not to exceed the given value more than two per cent of <u>the time</u>
Total Nitrogen (ug N/L)	50.00	80.00	100.00
Ammonia Nitrogen (ug NH <sub>4</sub> -N/L)	1.00	1.75	2.50
Nitrate + Nitrite Nitrogen (ug [NO <sub>3</sub> +NO <sub>2</sub> ]-N/L)	1.50	2.50	3.50
Total Phosphorus (ug P/L)	10.00	18.00	25.00
Chlorophyll a (ug/L)	0.06	0.12	0.20
Turbidity (N.T.U.)	0.03	0.10	0.20

L = liter

N.T.U. = Nephelometric Turbidity Units. A comparison of the intensity of light scattered by the sample under defined conditions with the intensity of light scattered by a standard reference suspension under the same conditions. The higher the intensity of scattered light, the higher the turbidity.

ug = microgram or 0.000001 grams

pH Units - shall not deviate more than 0.5 units from a value of 8.1.

Dissolved Oxygen - Not less than seventy-five per cent saturation, determined as a function of ambient water temperature and salinity.

Temperature - shall not vary more than one degree Celsius from ambient conditions.

Salinity - Shall not vary more than ten per cent from natural or seasonal changes considering hydrologic input and oceanographic factors.

(d) Area-specific criteria for the Kona (west) coast of the island of Hawaii.

(1) For all marine waters of the island of Hawaii from Loa Point, South Kona District, clockwise to Malae Point, North Kona District, excluding Kawaihae Harbor and Honokohau Harbor, and for all areas from the shoreline at mean lower low water to a distance 1000 m seaward:

(A) In areas where nearshore marine water salinity is greater than 32.00 parts per thousand the following specific criteria apply:

<u>Parameter</u>	<u>Geometric mean not to exceed the given single value</u>
Total Dissolved Nitrogen (ug N/L)	100.00
Nitrate + Nitrite Nitrogen (ug [NO <sub>3</sub> +NO <sub>2</sub> ]-N/L)	4.50
Total Dissolved Phosphorus (ug P/L)	12.50
Phosphate (ug PO <sub>4</sub> - P/L)	5.00
Ammonia Nitrogen (ug NH <sub>4</sub> - N/L)	2.50
Chlorophyll a (ug/L)	0.30
Turbidity (N.T.U.)	0.10

\* Specific criteria for Class A embayments apply to Honokohau Harbor and Kawaihae Harbor, see section 11-54-6(a)(3).

- (B) If nearshore marine water salinity is less than or equal to 32.00 parts per thousand the following parameters shall be related to salinity on the basis of a linear least squares regression equation:

$$Y = MX + B$$

where:

Y = parameter concentration(in ug/L)

X = salinity (in ppt)

M = regression coefficient (or "slope")

B = constant (or "Y intercept").

The absolute value of the upper 95 per cent confidence limit for the calculated sample regression coefficient (M) shall not exceed the absolute value of the following values:

<u>Parameter</u>	<u>M</u>
Nitrate and Nitrite Nitrogen (ug [NO3 + NO2]-N/L)	-31.92
Total Dissolved Nitrogen (ug N/L)	-40.35
Phosphate (ug PO4 - P/L)	-3.22
Total Dissolved Phosphorus (ug P/L)	-2.86

The specific criteria for ammonia nitrogen, chlorophyll a, and turbidity given in clause (i) also apply.

- (C) Parameter concentrations shall be determined along a horizontal transect extending seaward from a shoreline sample location using the following method: water samples shall be obtained

at distances of 1, 10, 50, 100, and 500 meters from the shoreline sampling location. Samples shall be collected within one meter of the water surface and below the air-water interface. Dissolved nutrient samples shall be filtered through media with particle size retention of 0.7 um. This sampling protocol shall be replicated not less than three times on different days over a period not to exceed fourteen days during dry weather conditions. The geometric means of sample measurements for corresponding offshore distances shall be used for regression calculations.

pH Units - shall not deviate more than 0.5 units from a value of 8.1, except at coastal locations where and when freshwater from stream, stormdrain or groundwater discharge may depress the pH to a minimum level of 7.0.

Dissolved Oxygen - Not less than seventy-five per cent saturation, determined as a function of ambient water temperature and salinity.

Temperature - Shall not vary more than one degree Celsius from ambient conditions.

Salinity - Shall not vary more than ten per cent from natural or seasonal changes considering hydrologic input and oceanographic factors.

L - liter

N.T.U. - Nephelometric Turbidity Units. A comparison of the intensity of light scattered by the sample under defined conditions with the intensity of light scattered by a standard reference suspension under the same conditions. The higher the intensity of scattered light, the higher the turbidity.

ug - microgram or 0.000001 grams. [Eff 11/12/82; am and comp 10/6/84; am and comp 04/14/88; am and comp 01/18/90; am and comp 10/29/92, am and comp 04/17/00; am and comp 10/2/04; comp 06/15/09; comp 10/21/12; am

and comp 12/6/13; am and comp **NOV 15 2014** ] (Auth:  
 HRS §§342D-1, 342D-4, 342D-5, Ch. 342E) (Imp: HRS  
 §§342D-4, 342D-5, Ch. 342E)

§11-54-7 Uses and specific criteria applicable to marine bottom types. (a) Sand beaches.

- (1) As used in this subsection:  
 "Sand beaches" means shoreline composed of the weathered calcareous remains of marine algae and animals (white sand), the weathered remains of volcanic tuff (olivine), or the weathered remains of lava (black sand). Associated animals are largely burrowers and are related to particle grain size, slope, and color of the beach.
- (2) Water areas to be protected:
  - (A) Class I - All beaches on the Northwestern Hawaiian Islands. These islands comprise that portion of the Hawaiian archipelago which lies northwest of the island of Kauai and is part of the State of Hawaii; including Nihoa Island, Necker Island, French Frigate Shoals, Brooks Banks, Gardiner Pinnacles, Dowsett and Maro Reef, Laysan Island, Lisianski Island, Pearl and Hermes Atoll, Gambia Shoal, and Kure Atoll.
  - (B) Class II - All beaches not in Class I.
- (3) The following criteria are specific to sand beaches:
  - (A) Episodic deposits of flood-borne sediment shall not occur in quantities exceeding an equivalent thickness of ten millimeters (0.40 inches) twenty-four hours after a heavy rainstorm.
  - (B) Oxidation - reduction potential (EH) in the uppermost ten centimeters (four

- inches of sediment shall not be less than +100 millivolts
- (C) No more than fifty per cent of the grain size distribution of sediment shall be smaller than 0.125 millimeters in diameter.
- (b) Lava rock shoreline and solution benches.
- (1) As used in this subsection:
- "Lava rock shorelines" means sea cliffs and other vertical rock faces, horizontal basalts, volcanic tuff beaches, and boulder beaches formed by rocks falling from above or deposited by storm waves. Associated plants and animals are adapted to the harsh physical environment and are distinctly zoned to the degree of wave exposure.
- "Solution benches" means sea level platforms developed on upraised reef or solidified beach rock by the erosive action of waves and rains. Solution benches are distinguished by a thick algal turf and conspicuous zonation of plants and animals.
- (2) Water areas to be protected:
- (A) Class I - All lava rock shorelines and solution benches in preserves, reserves, sanctuaries, and refuges established by the department of land and natural resources under chapter 195 or chapter 190, HRS, or similar reserves for the protection of marine life established under chapter 190, HRS, as amended; or in refuges or sanctuaries established by the U.S. Fish and Wildlife Service or the National Marine Fisheries Service.
- (B) Class II
- (i) All other lava rock shorelines not in Class I.
- (ii) The following solution benches:

<u>Maui</u>	<u>Oahu</u>
Kihei	Diamond Head
Papaula Point	Manana Island
	Makapuu
<u>Kauai</u>	Laie
Near Hanapepe	Kahuku
Salt Ponds	Mokuleia
Milolii	Makua
Nualolo	Makaha
Makaha	Maile
Mahaulepu	Lualualei
Kuhio Beach Park (Kukuiula)	Barbers Point

- (3) The following criteria are specific to lava rock shorelines and solution benches:
- (A) Episodic deposits of flood-borne sediment shall not occur in quantities exceeding an equivalent thickness of five millimeters (0.20 inches) for longer than twenty-four hours after a heavy rainstorm.
  - (B) The director shall determine parameters, measures, and criteria for bottom biological communities which may be affected by proposed actions. The location and boundaries of each bottom-type class will be clarified when situations require their identification. For example, when a discharge permit is applied for or a waiver pursuant to section 301(h) of the Federal Water Pollution Control Act (33 U.S.C. Section 1311) is required. Permanent benchmark stations may be required where necessary for monitoring purposes. The water quality standards for this subsection shall be deemed to be met if time series surveys of benchmark stations indicate no relative changes in the relevant biological



communities, as noted by biological community indicators or by indicator organisms which may be applicable to the specific site.

(c) Marine pools and protected coves.

(1) As used in this subsection:

"Marine pools" means waters which collect in depressions on sea level lava rock outcrops and solution benches and also behind large boulders fronting the sea. Pools farthest from the ocean have harsher environments and less frequent renewal of water and support fewer animals. Those closest to the ocean are frequently renewed with water, are essentially marine, and support more diverse fauna.

"Protected coves" means small inlets which are removed from heavy wave action or surge.

(2) Water areas to be protected.

(A) Class I.

(i) All marine pools and protected coves in preserves, reserves, sanctuaries, and refuges established by the department of land and natural resources under chapter 195 or chapter 190, HRS, or similar reserves for the protection of marine life established under chapter 190, HRS, as amended; or in refuges or sanctuaries established by the U.S. Fish and Wildlife Service or the National Fisheries Service.

(ii) Hawaii  
Honaunau  
Kiholo

(B) Class II.

<u>Hawaii</u>	<u>Maui</u>
Kalapana	Hana
Pohakuloa	Keanae
Kapalaoa	Napili
Kapoho	Puu Olai to
King's Landing	Cape
(Papai)	Hanamanioa
Hilo	Kipahulu
Leileiwi Point	
Wailua Bay	<u>Molokai</u>
	Cape Halawa
	Kalaupapa
	South Coast

Oahu  
 Diamond Head  
 Halona Blowhole to Makapuu  
 Mokuleia  
 Kaena Point  
 Makua  
 Punaluu

Kauai  
 Kealia  
 Mahaulepu  
 Hanamaulu  
 Poipu  
 Puolo Point

- (3) The following criteria are specific to marine pools and protected coves:
- (A) In marine pools and coves with sand bottoms, oxidation-reduction potential (EH) in the uppermost ten centimeters (four inches) of sediment shall not be less than +100 millivolts.
  - (B) In marine pools and coves with sand bottoms, no more than fifty per cent of the grain size distribution of the sediment shall be smaller than 0.125 millimeters in diameter.

- (C) Episodic deposits of flood-borne soil sediment shall not occur in quantities exceeding equivalent thicknesses for longer than twenty-four hours following a heavy rainstorm according to the following:
    - (i) No thicker than an equivalent of five millimeters (0.20 inches) on hard bottoms (other than living corals).
    - (ii) No thicker than an equivalent of ten millimeters (0.40 inches) on soft bottoms.
  - (D) The director shall determine parameters, measures, and criteria for bottom biological communities which may be affected by proposed actions. Permanent benchmark stations may be required where necessary for monitoring purposes. The water quality standards for this subsection shall be deemed to be met if time series surveys of benchmark stations indicate no relative changes in the relevant biological communities, as noted by biological community indicators or by indicator organisms which may be applicable to the specific site.
- (d) Artificial basins.
    - (1) As used in this subsection:

"Artificial basins" means dredged or quarried channels or harbors, and harbor-associated submerged structures. Many organisms can attach to the vertical structures, but the soft, shifting sediment bottoms of harbors may only be colonized by a few hardy or transient species.
    - (2) Class II water areas to be protected are as follows:
      - (A) Shallow draft harbors:

Hawaii

Wailoa River Boat  
Harbor  
Mahukona Harbor  
Keauhou Harbor  
Kailua-Kona Harbor  
Honokohau Boat Harbor  
Kawaihae Boat Harbor

Maui

Maalaea Boat  
Harbor  
Lahaina Boat  
Harbor  
Hana Harbor

Lanai

Manele Boat  
Harbor  
Kaunalapau  
Harbor

Molokai

Kalaupapa Anchorage  
Kaunakakai Small Boat Harbor  
Hale o Lono Harbor

Oahu

Heeia Kea Boat Harbor  
Kaneohe Marine Corps Air Station  
Kaneohe Yacht Club  
Hawaii Kai Marina (Kuapa Pond)  
Pokai Bay  
Waianae Boat Harbor  
Keehi Marine Center  
La Mariana Sailing Club  
Haleiwa Harbor  
Makani Kai Marina  
Keehi Boat Harbor  
Ala Wai Boat Harbor:  
Ala Wai Fuel Dock  
Hawaii Yacht Club  
Waikiki Yacht Club  
Ko Olina

Kauai

Nawiliwili Small Boat Harbor  
Kukuiula Boat Harbor  
Kikiaola Boat Harbor  
Port Allen Boat Harbor

(B) Deep draft commercial harbors:

Hawaii

Kuhio Bay (Hilo Harbor)  
Kawaihae Deep Draft Harbor

Maui

Kahului Harbor

Molokai

Kaunakakai Barge Harbor

Oahu

Honolulu Harbor  
Barbers Point Harbor  
Kewalo Basin

Kauai

Nawiliwili Harbor  
Port Allen Harbor

- (3) Specific criterion to be applied -  
Oxidation-reduction potential (EH) in the  
uppermost ten centimeters (four inches) of  
sediment shall not be less than -100  
millivolts.
- (e) Reef flats and reef communities.
- (1) As used in this subsection:  
"Nearshore reef flats" means shallow  
platforms of reef rock, rubble, and sand  
extending from the shoreline. Smaller,  
younger flats projected out as semicircular  
aprons while older, larger flats form wide  
continuous platforms. Associated animals  
are mollusks, echinoderms, worms,  
crustaceans (many living beneath the  
surface), and reef-building corals.  
"Offshore reef flats" means shallow,  
submerged platforms of reef rock and sand  
between depths of zero to three meters (zero  
to ten feet) which are separated from the  
shoreline of high volcanic islands by

lagoons or ocean expanses. Dominant organisms are bottom-dwelling algae. Biological composition is extremely variable. There are three types: patch, barrier, and atoll reef flats; quite different from one another structurally. The presence of heavier wave action, water more oceanic in character, and the relative absence of terrigenous influences distinguish offshore reef flats.

"Protected reef communities" means hard bottom aggregations, including scattered sand channels and patches, dominated by living coral thickets, mounds, or platforms. They are found at depths of ten to thirty meters (thirty-two to ninety-six feet) along protected leeward coasts or in shallow water (up to sea level) in sheltered lagoons behind atoll or barrier reefs and in the calm reaches of bays or coves.

"Wave-exposed reef communities" means aggregations, including scattered sand channels and patches, dominated by corals. They may be found at depths up to forty meters (approximately one hundred thirty feet) along coasts subject to continuous or heavy wave action and surge. Wave-exposed reef communities are dominated biologically by benthic algae, reef-building corals, and echinoderms.

(2) Water areas to be protected:

(A) Class I.

- (i) All reef flats and reef communities in preserves, reserves, sanctuaries, and refuges established by the department of land and natural resources under chapter 195 or chapter 190, HRS, or similar reserves for the protection of marine life under chapter 190, HRS, as amended; or

- in refuges or sanctuaries established by the U.S. Fish and Wildlife Service or the National Marine Fisheries Service;
- (ii) Nearshore reef flats:
- |                        |              |
|------------------------|--------------|
| <u>Hawaii</u>          | <u>Maui</u>  |
| Puako                  | Honolua      |
| <u>Lanai</u>           | <u>Oahu</u>  |
| Northwest Lanai Reef   | Hanauma Bay  |
| <u>Molokai</u>         | <u>Kauai</u> |
| Western Kalaupapa      | Nualolokai   |
| Southeast Molokai Reef | Hanalei      |
| Honomuni Harbor        | (Anini to    |
| Kulaalamihi Fishpond   | Haena)       |
- (iii) Offshore reef flats:
- Moku o Loe (Coconut Island, Kaneohe Bay, Oahu)
  - Kure Atoll
  - Pearl and Hermes Atoll
  - Lisianski Island
  - Laysan Island
  - Maro Reef
  - French Frigate Shoals
- (iv) Wave exposed reef communities:
- Hawaii
- 1823 Lava Flow (Punaluu)
  - 1840 Lava Flow (North Puna)
  - 1868 Lava Flow (South Point)
  - 1887 Lava Flow (South Point)
  - 1955 Lava Flow (South Puna)
  - 1960 Lava Flow (Kapoho)
  - 1969 Lava Flow (Apuna Point)
  - 1970 Lava Flow (Apuna Point)
  - 1971 Lava Flow (Apuna Point)
  - 1972 Lava Flow (Apuna Point)
  - 1973 Lava Flow (Apuna Point)
- Maui
- Hana Bay

Makuleia Bay (Honolua)

Molokini Island

All wave exposed reef communities

Molokai

Moanui Kahinapohaku Waikolu -

Kalawao

Halawa Bay

Oahu

Sharks Cove (Pupukea)

Moku Manu (Islands)

Outer Hanauma Bay

Waimea Bay

Kawela Bay

Kahana Bay

Kauai

Ke`e Beach

Poipu Beach

Kipu Beach

Niihau

All wave exposed communities

Lehua (off Niihau)

All wave exposed communities

(v) Protected reef communities:

Hawaii

Puako

Honaunau

Kealakekua

Kiholo

Anaehoomalu

Hapuna

Kahaluu Bay

Keaweula (North Kohala)

Milolii Bay to Keawaiki

Kailua-Kaiwi (Kona)



Onomea Bay  
1801 Lava Flow (Keahole or Kiholo)  
1850 Lava Flow (South Kona)  
1859 Lava Flow (Kiholo)  
1919 Lava Flow (Milolii)  
1926 Lava Flow (Milolii)

Maui  
Honolua

Ahihi-La Perouse (including 1790  
Lava Flow at Cape Kinau)

Molokini Island  
All protected reef communities

Lanai  
Manele  
Hulopoe

<u>Molokai</u>	<u>Oahu</u>
Southeast Molokai	Hanauma Bay
Kalaupapa	Moku o Loe
Honomuni Harbor	(Coconut Island, Kaneohe Bay)

Kauai  
Hoai Bay (Poipu)

Northwestern Hawaiian Islands  
Kure Atoll Lagoon  
Pearl and Hermes Lagoon  
Lisianski Lagoon  
Maro Reef Lagoon  
French Frigate Shoals Lagoon

(B) Class II.

- (i) Existing or planned harbors may be located within nearshore reef flats showing degraded habitats and only where feasible alternatives are lacking and upon written approval by the director,

considering environmental impact and the public interest pursuant to section 342D-6, HRS.

Hawaii

Blonde Reef (Hilo Harbor)  
Kawaihae Small Boat Harbor

Maui

Lahaina Harbor  
Kahului Harbor

Lanai

Manele

Molokai

Kaunakakai Harbor  
Hale o Lono Harbor  
Palaau (2.4 kilometers/1.5 mile,  
east of Pakanaka Fishpond)

Oahu

Keehi Boat Harbor  
Ala Moana Reef  
Honolulu Harbor  
Heeia Harbor  
Kaneohe Yacht Club  
Ala Wai Harbor  
Haleiwa Boat Harbor  
Maunalua Bay  
Pearl Harbor  
Kaneohe Bay  
Kahe

All other nearshore reef flats not in Class I;

(ii) Offshore reef flats:

Oahu

Kapapa Barrier Reef  
Kaneohe Patch Reefs (Kaneohe Bay)

(iii) All other wave exposed or protected reef communities not in Class I.

(3) Specific criteria to be applied to all reef flats and reef communities: No action shall be undertaken which would substantially risk

damage, impairment, or alteration of the biological characteristics of the areas named herein. When a determination of substantial risk is made by the director, the action shall be declared to be contrary to the public interest and no other permits shall be issued pursuant to chapter 342D, HRS.

- (A) Oxidation-reduction potential (EH) in the uppermost ten centimeters (four inches) of sand patches shall not be less than +100 millivolts;
- (B) No more than fifty per cent of the grain size distribution of sand patches shall be smaller than 0.125 millimeters in diameter;
- (C) Episodic deposits of flood-borne soil sediment shall not occur in quantities exceeding equivalent thicknesses for longer than twenty-four hours after a heavy rainstorm as follows:
  - (i) No thicker than an equivalent of two millimeters (0.08 inches) on living coral surfaces;
  - (ii) No thicker than an equivalent of five millimeters (0.2 inches) on other hard bottoms;
  - (iii) No thicker than an equivalent of ten millimeters (0.4 inches) on soft bottoms;
- (D) The director shall determine parameters, measures, and criteria for bottom biological communities which may be affected by proposed actions. The location and boundaries of each bottom-type class shall be clarified when situations require their identification. For example, the location and boundaries shall be clarified when a discharge permit is applied for or a waiver pursuant to

Section 301(h) of the Federal Water Pollution Control Act of 1972 (33 U.S.C. 1251 et seq.) is required. Permanent benchmark stations may be required where necessary for monitoring purposes. The water quality standards for this subsection shall be deemed to be met if time series surveys of benchmark stations indicate no relative changes in the relevant biological communities, as noted by biological community indicators or by indicator organisms which may be applicable to the specific site.

- (f) Soft bottom communities.
  - (1) As used in this subsection:
    - "Soft bottom communities" means poorly described and "patchy" communities, mostly of burrowing organisms, living in deposits at depths between two to forty meters (approximately six to one hundred thirty feet). The particle size of sediment, depth below sea level, and degree of water movement and associated sediment turnover dictate the composition of animals which rework the bottom with burrows, trails, tracks, ripples, hummocks, and depressions.
  - (2) Water areas to be protected:
    - Class II - All soft bottom communities.
  - (3) Specific criteria to be applied - Oxidation-reduction potential (EH) in the uppermost ten centimeters (four inches) of sediment should not be less than -100 millivolts. The location and boundaries of each bottom-type class shall be clarified when situations require their identification. For example, the location and boundaries shall be clarified when a discharge permit is applied for or a waiver pursuant to Section 301(h) of the Act is required. [Eff 11/12/82; am and comp 10/6/84; am and comp

04/14/88; am and comp 01/18/90; am and comp  
10/29/92, am and comp 04/17/00; am and comp  
10/2/04; comp 06/15/09; comp 10/21/12; am  
and comp 12/6/13; comp **NOV 1 5 2014** ] (Auth:  
HRS §§342D-1, 342D-4, 342D-5, Ch. 342E)  
(Imp: HRS §§342D-4, 342D-5, Ch. 342E)

§11-54-8 Recreational criteria for all State waters. (a) These criteria are designed to protect the public from exposure to harmful levels of pathogens while participating in water-contact activities. The specific criteria for enterococcus shall be expressed in colony forming units (CFU) per one hundred milliliters or as a most probable number (MPN) per one hundred milliliters, as specified by the analytical method used.

(b) Enterococcus content shall not exceed a geometric mean of 35 colony forming units per one hundred milliliters over any thirty day interval.

(c) A Statistical Threshold Value (STV) of 130 per one hundred milliliters shall be used for enterococcus. The STV shall not be exceeded by more than ten percent of samples taken within the same thirty day interval in which the geometric mean is calculated.

(d) State waters in which enterococcus content does not exceed the standard shall not be lowered in quality.

(e) Raw or inadequately treated sewage, sewage for which the degree of treatment is unknown, or other pollutants of public health significance, as determined by the director of health, shall not be present in natural public swimming, bathing or wading areas. Warning signs shall be posted at locations where human sewage has been identified as temporarily contributing to the enterococcus count. [Eff  
11/12/82; am and comp 10/6/84; am and comp 04/14/88;  
am and comp 01/18/90; am and comp 10/29/92, am and  
comp 04/17/00; am and comp 10/2/04; am and comp  
06/15/09; comp 10/21/12; am and comp 12/6/13; am and  
comp **NOV 1 5 2014** ] (Auth: HRS §§342D-1, 342D-4,

342D-5, Ch. 342E) (Imp: HRS §§342D-4, 342D-5, Ch. 342E)

§11-54-9 Zones of mixing. (a) As used in this section, "zones of mixing" means limited areas around outfalls and other facilities to allow for the initial dilution of waste discharges.

(b) Zones of mixing for the assimilation of domestic, agricultural, and industrial discharges which have received the best degree of treatment or control are recognized as being necessary. It is the objective of these limited zones to provide for a current realistic means of control over the placement and manner of discharges or emissions so as to achieve the highest attainable level of water quality or otherwise to achieve the minimum environmental impact considering initial dilution, dispersion, and reactions from substances which may be considered to be pollutants.

(c) Establishment, renewal, and termination.

- (1) Application for establishment of a zone of mixing shall be made concurrently with any discharge permits whenever applicable and the conditions of a zone of mixing shall be incorporated as conditions of the discharge permits. Every application for a zone of mixing shall be made on forms furnished by the director and shall be accompanied by a complete and detailed description of present conditions, how present conditions do not conform to standards, and other information as the director may prescribe.
- (2) Each application for a zone of mixing shall be reviewed in light of the descriptions, statements, plans, histories, and other supporting information as may be submitted upon the request of the director, and in light of the effect or probable effect upon

water quality standards established pursuant to this chapter.

- (3) Whenever an application is approved, the director shall establish the zone of mixing, taking into account the environmental impact, including but not limited to factors such as the protected uses of the body of water, existing natural conditions of the receiving water, character of the effluent, and the adequacy of the design of the outfall and diffuser system to achieve maximum dispersion and assimilation of the treated or controlled waste with a minimum of undesirable or noticeable effect on the receiving water.
- (4) Approval of a zone of mixing shall be made either after a public hearing is held by the director in the county where the source is situated, in accordance with chapters 91 and 92, HRS and the rules of practice and procedures of the department, or after the public notification and comment process duly established for a discharge permit in the case when the zone of mixing is being considered concurrently with the discharge permit.
- (5) No zone of mixing shall be established by the director unless the application and the supporting information clearly show that:
  - (A) The continuation of the function or operation involved in the discharge by the granting of the zone of mixing is in the public interest;
  - (B) The discharge occurring or proposed to occur does not substantially endanger human health or safety;
  - (C) Compliance with the existing water quality standards from which a zone of mixing is sought would produce serious hardships without equal or greater benefits to the public; and

- (D) The discharge occurring or proposed to occur does not violate the basic standards applicable to all waters, will not unreasonably interfere with any actual or probable use of the water areas for which it is classified, and has received (or in the case of a proposed discharge will receive) the best degree of treatment or control.
- (6) Any zone of mixing or renewal thereof shall be established within the requirements of this section and for time periods and under conditions consistent with the reasons therefore and within the following limitations:
- (A) If the zone of mixing is established on the grounds that there is no reasonable means known or available for the adequate prevention, control, or abatement of the discharge involved, it shall be allowed only until the necessary means for prevention, control or abatement become practicable, and subject to the taking of any substitute or alternative measures that the director may prescribe. No renewal of a zone of mixing established under this subsection shall be allowed without a thorough review of known and available means of preventing, controlling, or abating the discharge involved;
  - (B) The director may issue a zone of mixing for a period not exceeding five years;
  - (C) Every zone of mixing established under this section shall include, but not be limited to, conditions requiring the applicant to perform appropriate effluent and receiving water sampling including monitoring of bottom biological communities and report the results of each sampling to the



director. A program of research to develop reasonable alternatives to the methods of treatment or control in use by the applicant may be required if research is deemed prudent by the director; and

- (D) In order to prevent high temperature discharges from violating section 11-54-04(a)(4), no new or increased domestic, industrial, or other controllable source shall discharge at a maximum temperature which will cause temperatures to exceed three degrees Celsius above ambient, or thirty degrees Celsius, whichever is less, within one meter of the bottom within a zone of mixing. For discharges with or without submerged outfalls, the director may make a limited allowance for higher discharge temperatures if there is satisfactory demonstration that the elevated temperature will not cause damage to the local aquatic community.
- (7) Any zone of mixing established pursuant to this section may be renewed from time to time on terms and conditions and for periods not exceeding five years which would be appropriate on initial establishment of a zone of mixing, provided that the applicant for renewal had met all of the conditions specified in the immediately preceding mixing, and provided further that the renewal and the zone of mixing established in pursuance thereof shall provide for the discharge not greater in quantity of mass emissions than that attained pursuant to the terms of the immediately preceding zone of mixing at its expiration. Any new zones of mixing or requests for zone of mixing renewals for wastewater treatment plants

(WWTP) performing primary treatment shall comply with section 301(h) of the Federal Water Pollution Control Act of 1972 (33 U.S.C. 1251). No renewal shall be allowed except upon application. Any renewal application shall be made at least one hundred and eighty days prior to the expiration of the zone of mixing.

- (8) No zone of mixing established pursuant to this part shall be construed to prevent or limit the application of any emergency provisions and procedures provided by law.
- (9) The establishment of any zone of mixing shall be subject to the concurrence of the U.S. Environmental Protection Agency.
- (10) Each mixing zone may be subject to revocation, suspension, or modification if, after notice and opportunity for a hearing pursuant to chapter 91, HRS and the rules of practice and procedures of the department, the director determines that the terms specified in section 342D-6, HRS have been violated. In taking any action, the director may consider operating records, compliance investigations, or other information regarding discharge quality or impact on receiving waters. The action shall be effected by giving written notice to the permittee, which shall contain the reasons for the action.
- (11) The director shall be notified within thirty days of the permanent discontinuance of a discharge. The zone of mixing shall terminate thirty days after such notification has been received.
- (12) Upon expiration of the period stated in the designation, the zone of mixing shall automatically terminate and no rights shall become vested in the designee. [Eff 11/12/82; am and comp 10/6/84; am and comp 04/14/88; am and comp 01/18/90; am and comp

10/29/92, am and comp 04/17/00; am and comp  
10/2/04; comp 06/15/09; comp 10/21/12; am  
and comp 12/6/13; comp NOV 15 2014 ]  
(Auth: HRS §§342D-1, 342D-4, 342D-5) (Imp:  
HRS §§342D-4, 342D-5)

§11-54-9.1 Water quality certification. As used  
in sections 11-54-9.1.01 to 11-54-9.1.10:

"33 CFR" means the Code of Federal Regulations,  
Title 33, Corps of Engineers, Department of the Army,  
Department of Defense, revised as of July 1, 2011,  
unless otherwise specified.

"40 CFR" means the Code of Federal Regulations,  
Title 40, Protection of the Environment, revised as of  
July 1, 2011, unless otherwise specified.

"Act" means the Clean Water Act (formerly  
referred to as the Federal Water Pollution Control Act  
or Federal Water Pollution Control Act Amendments of  
1972) Public Law 92-500, as amended by Public Law 95-  
217, Public Law 95-483 and Public Law 97-117, 33  
U.S.C. section 1251 et. seq.

"Agent" means a duly authorized representative of  
the owner as defined in section 11-55-7(b).

"Discharge" means the same thing as defined in  
Section 502(16) of the Act.

"Discharge of a pollutant" and "discharge of  
pollutants" means the same thing as defined in section  
502(12) of the Act.

"Duly authorized representative" means a person  
or position as defined in 40 CFR section 122.22(b).

"License or permit" means any permit,  
certificate, approval, registration, charter,  
membership, statutory exemption or other form of  
permission granted by an agency of the federal  
government to conduct any activity which may result in  
any discharge into navigable waters.

"Licensing or permitting agency" means any agency  
of the federal government to which a federal  
application is made for a "license or permit."

"Navigable waters" means the waters of the United  
States, including the territorial seas.

"Owner" means the person who owns any "facility" or "activity" which results in any discharge into navigable waters.

"Pollutant" means the same thing as defined in section 502(6) of the Act.

"Territorial seas" means the belt of the seas measured from the line of ordinary low water along that portion of the coast which is in direct contact with the open sea and the line marking the seaward limit of inland waters, and extending seaward a distance of three miles.

"Water quality certification" or "certification" means a statement which asserts that a proposed discharge resulting from an activity will not violate applicable water quality standards and the applicable provisions of sections 301, 302, 303, 306 and 307 of the Act. A water quality certification is required by section 401 of the Act from any applicant for a federal license or permit to conduct any activity, including the construction or operation of facilities which may result in any discharge into navigable waters.

"Water quality certification application" means any forms provided by the director for use in obtaining the water quality certification.

"Water quality standards" means standards established pursuant to section 10(c) of the Act, and state-adopted water quality standards for navigable waters which are not interstate waters.

"Waters of the United States" or "waters of the U.S." means:

- (1) All waters which are currently used, were used in the past, or may be susceptible to use in interstate or foreign commerce, including all waters which are subject to the ebb and flow of the tide;
- (2) All interstate waters, including interstate "wetlands";
- (3) All other waters such as intrastate lakes, rivers, streams (including intermittent streams), mudflats, sandflats, "wetlands,"

sloughs, prairie potholes, wet meadows, playa lakes, or natural ponds the use, degradation, or destruction of which would affect or could affect interstate or foreign commerce including any such waters:

- (A) Which are or could be used by interstate or foreign travelers for recreational or other purposes;
  - (B) From which fish or shellfish are or could be taken and sold in interstate or foreign commerce; or
  - (C) Which are used or could be used for industrial purposes by industries in interstate commerce;
- (4) All impoundments of waters otherwise defined as waters of the United States under this definition;
  - (5) Tributaries of waters identified in paragraphs (1) through (4) of this definition;
  - (6) The territorial sea; and
  - (7) "Wetlands" adjacent to waters (other than waters that are themselves wetlands) identified in paragraphs (1) through (6) of this definition. [Eff and comp 04/14/88; am and comp 01/18/90; am and comp 10/29/92; am and comp 04/17/00; am and comp 10/2/04; comp 06/15/09; comp 10/21/12; am and comp 12/6/13; comp\_ NOV 15 2014 ] (Auth: HRS §§342D-4, 342D-5, 342D-53) (Imp: HRS §§342D-4, 342D-5, 342D-6)

§11-54-9.1.01 Water quality certification; contents of certification. (a) A certification made by the department shall include:

- (1) The legal name(s), street address, contact person's name and position title, and telephone and fax numbers of the owner and,

if applicable, its duly authorized representative;

- (2) A statement that the director has either:
  - (A) Examined the application made by the owner or its duly authorized representative to the licensing or permitting agency (specifically identifying the number or code affixed to the application) and bases its certification upon an evaluation of the information contained in the application which is relevant to water quality considerations; or
  - (B) Examined other information provided by the owner or its duly authorized representative sufficient to permit the director to make the statement described in paragraph (a)(3);
- (3) A statement that there is reasonable assurance that the activity will be conducted in a manner which will not violate applicable water quality standards;
- (4) A statement of any conditions which the director considers necessary or desirable with respect to the discharge resulting from an activity; and
- (5) Other information the director determines to be appropriate.

(b) The director shall issue the certification after evaluating the complete water quality certification application, comments received during the public comment period, any record of a public hearing held pursuant to section 11-54-09.1.03, other information and data the director considers relevant, and after the director determines that there is reasonable assurance that applicable water quality standards will not be violated and the best practicable methods of control will be applied to a discharge resulting from an activity including the construction and operation of a facility

(c) The department shall process applications for permits and water quality certifications for the reconstruction, restoration, repair, or reuse of any Hawaiian fishpond that meets the requirements of chapter 183B, HRS, before all other permits and certifications. The director shall render a decision on the completeness of any application for the permit or water quality certification within thirty days of receipt. Applications for fishpond reconstruction, restoration, or repair that are incomplete shall be denied without prejudice. The director shall render a decision on any complete application for a permit or water quality certification for any fishpond within one hundred fifty days.

(d) The director, at the director's discretion or after consideration of information presented by the owner or its duly authorized representative, the licensing or permitting agency, other government agencies, or interested parties, may modify or revoke an issued certification or waiver. [Eff and comp 4/14/88; am and comp 01/18/90; am and comp 10/29/92; am and comp 04/17/00; am and comp 10/2/04; comp 06/15/09; comp 10/21/12; am and comp 12/6/13; comp NOV 1 5 2014 ] (Auth: HRS §§342D-4, 342D-5, 342D6.5, 342D-53) (Imp: HRS §§342D-342D-6, 342D6.5, 342D-5)§11-54-09.1.02

§11-54-9.1.02 Water quality certification;  
contents of water quality certification application.

(a) The owner or its duly authorized representative shall submit a complete water quality certification application for the discharge resulting from an activity. The water quality certification application shall include at a minimum:

- (1) The legal name(s), street address, contact person's name and position title, and telephone and fax numbers of the owner and, if applicable, its duly authorized representative;

- (2) The company or organization name, contact person's name and position title, and telephone and fax numbers of the emergency contact(s);
- (3) The name, street address, contact person's name and position title, telephone and fax numbers, island, and tax map key number(s) for the project;
- (4) Associated existing or pending federal and environmental permits and corresponding file numbers;
- (5) The name(s) of the navigable water where the discharge occurs, the latitude and longitude of the discharge point(s), the classification of the navigable water, and the associated existing recreational uses;
- (6) The scope of work or a description of the overall project including: the construction or operation of facilities which may result in discharges into navigable waters; the proposed discharge resulting from an activity; and specific biological, chemical, physical, thermal, and other pertinent characteristics of the discharge resulting from an activity;
- (7) If applicable, a description of the function and operation of equipment or facilities to control discharges, including specification of the methods of control to be used;
- (8) The estimated dates on which the activity will begin and end and the date or dates on which the discharge(s) will take place;
- (9) If applicable, a description of the methods and means being used or proposed to monitor the quality and characteristics of the discharge and the operation of equipment or facilities employed in the control of the proposed discharges and a map showing the location(s) of the monitoring point(s);
- (10) The statement of assurance, statement of choice for publication, and if applicable,



an authorization statement, with the owner's original signature. Any signatures required for the water quality certification application shall be provided as described in 40 CFR Section 122.22(a);

- (11) Supporting documentation (e.g. maps, plans, specifications, copies of associated federal permits or licenses, federal applications, Environmental Assessments or Environmental Impact Statements, as applicable, etc.);
- (12) Additional information regarding any irregularities or unique features of the project; and
- (13) Additional information as required by the director.

(b) The director shall notify the owner or its duly authorized representative in writing if a water quality certification application is incomplete or otherwise deficient. A description of the additional information necessary to complete the water quality certification application or to correct the deficiency shall be included in the written notice. If a water quality certification application is incomplete or otherwise deficient, processing of the water quality certification application shall not be completed until the time the owner or its duly authorized representative has supplied the information or otherwise corrected the deficiency. Failure to provide additional information or to correct a deficiency shall be sufficient grounds for denial of the certification or termination of the processing of the water quality certification application.

(c) The director shall notify the owner or its duly authorized representative in writing when a water quality certification application is considered complete. The director shall act on a request for certification within a period which shall not exceed one year from the date when the water quality certification application was considered complete.

(d) The owner or its duly authorized representative shall notify the department in writing

of changes which may affect the water quality certification application and certification process.

(e) Each owner who submits a water quality certification application shall pay a filing fee of \$1,000. This filing fee shall be submitted with the water quality certification application and shall not be refunded nor applied to any subsequent water quality certification application following final action of denial or termination of the processing of the water quality certification application.

- (1) Fees shall be made payable to the "State of Hawaii" in the form of a cashier's check or money order;
- (2) Water quality certification application(s) submitted by the U.S. Army Corps of Engineers, Honolulu Engineer District, for the purpose of adopting regional or nationwide general permit(s), in accordance with 33 CFR Parts 325 and 330, respectively, shall be exempt from the payment of filing fees.

(f) If a project or activity requiring a federal permit or license involves or may involve the discharge of a pollutant or pollutants and is initiated or completed without a water quality certification, the director may process an after-the-fact water quality certification application as follows: after-the-fact water quality certification application.

may be accepted and processed only for the limited purpose of deeming projects or activities requiring federal permits or licenses to be properly permitted or licensed forward of the date of the water quality certification or waiver. No water quality certification or waiver shall be issued which allows the retroactive permitting or licensing of projects or activities before the date the water quality certification or waiver was issued. A water quality certification or waiver may be issued if the following criteria are met:

- (1) The project or activity is not the subject of an ongoing enforcement action by the federal, state or county government;
- (2) Any adverse impacts upon water quality resulting from the project or activity have been mitigated to the maximum extent feasible; and
- (3) The project or activity will not cause or contribute to any lack of attainment of water quality standards set forth in this chapter.

(g) Written notification by the department under subsection (b) is complete upon mailing or sending a facsimile transmission of the document or actual receipt of the document by the owner or its duly authorized representative. [Eff and comp 04/14/88; am and comp 01/18/90; am and comp 10/29/92; am and comp 04/17/00; am and comp 10/2/04; comp 06/15/09; comp 10/21/12; am and comp 12/6/13; comp **NOV 15 2014** ]  
(Auth: HRS §§342D-4, 342D-5, 342D-53) (Imp: HRS §§342D-4, 342D-5, 342D-6)

§11-54-9.1.03 Water quality certification; notice and hearing. The director may provide the opportunity for public comment or hearing(s) or both to consider the issuance of a water quality certification. A notice shall be published in accordance with chapters 91 and 92, HRS. The director shall inform the owner or its duly authorized representative in writing that the action has been taken. All publication and mailing costs associated with the public notification of the director's tentative determinations with respect to the water quality certification application shall be paid by the owner to the appropriate newspaper agency or agencies determined by the director. Failure to provide and pay for public notification, as considered appropriate by the director, may result in a delay in the certification process. [Eff and comp 04/14/88; am and

comp 01/18/90; am and comp 10/29/92; am and comp 04/17/00; am and comp 10/2/04; comp 06/15/09; comp 10/21/12; comp 12/6/13; comp NOV 15 2014 ] (Auth: HRS §§342D-4, 342D-5, 342D-53) (Imp: HRS §§342D-4, 342D-5, 342D-6)

§11-54-9.1.04 Water quality certification; waiver. (a) If the director fails or refuses to act on a request for certification within one year after receipt of a complete water quality certification application, then the certification requirements of section 11-54-9.1 shall be waived with respect to the federal application.

(b) If the discharge resulting from an activity receives a determination to be covered under a nationwide permit authorization, thereby fulfilling specific conditions of that permit pursuant to 33 CFR sections 330.4, 330.5, and 330.6, then the director will determine, on a case-by-case basis, which projects are considered minor and non-controversial. Certification requirements of section 11-54-9.1 shall be waived for minor and non-controversial activities within one year of receipt of a complete water quality certification application. [Eff and comp 04/14/88; am and comp 01/18/90; am and comp 10/29/92; am and comp 04/17/00; am and comp 10/2/04; comp 06/15/09; comp 10/21/12; am and comp 12/6/13; comp NOV 15 2014 ] (Auth: HRS §§342D-4, 342D-5, 342D-53) (Imp: HRS §§342D-4, 342D-5, 342D-6)

§11-54-9.1.05 Water quality certification; adoption of new water quality standards.

(a) The licensee or permittee shall comply with any new water quality standards as adopted by the department.

(b) In any case where:

- (1) A certification or waiver was issued without applicable water quality standards;
- (2) Water quality standards applicable to the waters into which the activity may discharge are subsequently established before the activity is completed; or
- (3) The director determines that the activity is violating new water quality standards;

The director shall then notify the licensee or permittee and the licensing or permitting agency of the violation.

(c) If the licensee or permittee fails within one hundred eighty days of the date of the notice to cease the violation, the director shall notify the licensing or permitting agency that the licensee or permittee has failed to comply with the standards. The director, at the director's discretion, shall also revoke the certification or waiver or recommend suspension of the applicable license or permit pursuant to section 401 of the Act.

(d) The director shall notify the licensing or permitting agency that, in the director's opinion, there is reasonable assurance that applicable water quality standards will not be violated because the licensee or permittee took appropriate action to comply with the applicable water quality standards after their license or permit was suspended pursuant to subsection (c).

(e) This section shall not preclude the department from taking other enforcement action authorized by law. [Eff and comp 04/14/88; am and comp 01/18/90; am and comp 10/29/92; am and comp 04/17/00; am and comp 10/2/04; comp 06/15/09; comp 10/21/12; am and comp 12/6/13; comp NOV 15 2014 ] (Auth: HRS §§342D-4, 342D-5, 342D-53s) (Imp: HRS §§342D-4, 342D-5, 342D-6)

§11-54-9.1.06 Water quality certification; inspection of facility or activity before operation.

Where any facility or activity has received certification or waiver pursuant to sections 11-54-9.1.01 to 11-54-9.1.09 in connection with the issuance of a license or permit for construction, and where the facility or activity is not required to obtain an operating license or permit, the director, prior to the initial operation of the facility or activity, shall be afforded the opportunity to inspect the facility or activity for the purpose of determining if the manner in which the facility or activity will be operated or conducted will violate applicable water quality standards. [Eff and comp 04/14/88; am and comp 01/18/90; am and comp 10/29/92; am and comp 04/17/00; am and comp 10/2/04; comp 06/15/09; comp 10/21/12; comp 12/6/13; comp NOV 15 2014 ] Auth: HRS §§342D-4, 342D-5, 342D-53) (Imp: HRS §§342D-4, 342D-5, 342D-6)

§11-54-9.1.07 Water quality certification; notification to licensing or permitting agency. If the director, after an inspection pursuant to section 11-54-9.1.06 determines that operation of the proposed facility or activity will violate applicable water quality standards, the director shall so notify the owner or, if applicable, its duly authorized representative and the licensing or permitting agency. [Eff and comp 04/14/88; am and comp 01/18/90; am and comp 10/29/92; am and comp 04/17/00; am and comp 10/2/04; comp 06/15/09; comp 10/21/12; comp 12/6/13; comp NOV 15 2014 ] (Auth: HRS §§342D-4, 342D-5, 342D-53) (Imp: HRS §§342D-4, 342D-5, 342D-6)

§11-54-9.1.08 Water quality certification; termination or suspension. Where a licensing or permitting agency, following a public hearing,

suspends a license or permit after receiving the director's notice and recommendation pursuant to section 11-54-9.1.07 the owner or its duly authorized representative may submit evidence to the director, that the facility or activity has been modified so as not to violate applicable water quality standards. If the director determines that the applicable water quality standards have not been and will not be violated, the director shall so notify the licensing or permitting agency. [Eff and comp 04/14/88; am and comp 01/18/90; am and comp 10/29/92; am and comp 04/17/00; am and comp 10/2/04; comp 06/15/09; comp 10/21/12; comp 12/6/13; comp **NOV 15 2014** ] (Auth: HRS §§342D-4, 342D-5, 342D-53) (Imp: HRS §§342D-4, 342D-5, 342D-6)

§11-54-9.1.09 Water quality certification; review and advice. The director may, and upon request shall, provide licensing and permitting agencies with determinations, definitions, and interpretations to the meaning and content of state water quality standards. The director may, and upon request shall, also advise licensing and permitting agencies of the status of compliance by the owner(s) of a water quality certification with the conditions and requirements of applicable water quality standards. [Eff and comp 04/14/88; am and comp 01/18/90; am and comp 10/29/92; am and comp 04/17/00; am and comp 10/2/04; comp 06/15/09; comp 10/21/12; comp 12/6/13; comp **NOV 15 2014** ] (Auth: HRS §§342D-4, 342D-5, 342D-53) (Imp: HRS §§342D-4, 342D-5, 342D-6)

§11-54-10 Water quality analyses. (a) Laboratory analysis shall be performed by a laboratory approved by the department.

(b) Where applicable, analysis to determine compliance with these rules shall be by:

Parameter

Sample Collection  
(Phytoplankton and other  
Bioassays)

Reference

Standard Methods for the  
Examination of Water and  
Waste Water, twenty first  
edition, APHA

Sample Preservation and  
Holding Time,  
Bacteriological and  
Chemical Methodology

"Guidelines Establishing  
Test Procedures for the  
Analysis of Pollutants,"  
Federal Register, July 1,  
2011 (40 CFR 136)

"A Manual of Chemical and  
Biological Methods for  
Seawater Analysis" T.R.  
Parsons, Y. Maita, and C.M.  
Lalli, 1984, Pergamon  
Press, New York.

"Methods of Seawater  
Analysis", 2nd, Revised and  
Extended Edition, ed. by K.  
Grashof, M. Erhardt, K.  
Kremling, 1983. Verlag  
Chemie, Weinheim, Germany.



Toxicity Test

EPA 821-R-02-031, Short-Term Methods For Estimating the Chronic Toxicity of Effluents and Receiving Waters to Freshwater Organisms, 4<sup>th</sup> edition, October 2002.

or:

EPA 821-R-02-012, Methods For Measuring the Acute Toxicity of Effluents and Receiving waters to Freshwater and Marine Organisms, 5<sup>th</sup> edition, October 2002.

or:

EPA 821-R-02-014, Short-Term Methods For Estimating the Chronic Toxicity of Effluents and Receiving Waters to Marine and Estuarine Organisms, 3<sup>rd</sup> edition, October 2002.

or:

EPA 833-R-10-003, National Pollutant Discharge Elimination System Test of Significant Toxicity Implementation Document, June 2010.

or:

EPA 833-R-10-004, National Pollutant Discharge

Elimination System Test of  
Significant Toxicity  
Technical Document, June  
2010.

or:

EPA/600/R-12/022, Tropical  
Collector Urchin,  
*Tripneustes gratilla*,  
Fertilization Test Method,  
April 2012.

Quality Control  
(Bacteriological and  
Biology) and Chemistry

EPA/600/4-79-019, Handbook  
for Analytical Quality  
Control in Water and  
Wastewater Laboratories,  
March 1979.

Kona Coast Area Specific  
Standards

Rationale for the  
Development of Area-  
Specific Water Quality  
Criteria for the West Coast  
of The Island of Hawaii and  
Procedures for Their Use.  
Hawaii State Department of  
Health. March 1997.

or as otherwise previously specified or approved by  
the director. [Eff 11/12/82; am and comp 10/6/84; am  
and comp 04/14/88; am and comp 01/18/90; am and comp  
10/29/92, am and comp 04/17/00; am and comp 10/2/04;  
comp 06/15/09; comp 10/21/12; am and comp 12/6/13;  
comp **NOV 15 2014** ] (Auth: HRS §§342D-1, 342D-4,  
342D-5, Ch. 342E) (Imp: HRS §§342D-4, 342D-5, Ch.  
342E)

§11-54-11 Schedule of compliance. (a) A schedule of compliance is an NPDES implementation tool that applies to the implementation of water quality standards through NPDES permits only.

(b) The director may issue a schedule of compliance in an individual NPDES permit for the implementation of effluent limits derived from the water quality criteria in this chapter if the director makes a finding that the discharger cannot immediately comply with the water quality based effluent limitations upon the effective grant of the permit.

(c) A schedule of compliance may be included in an individual NPDES permit issued by the director pursuant to chapter 342D, HRS.

(d) A schedule of compliance in an NPDES permit is allowed only for water quality-based effluent limits based upon a new, revised, or newly interpreted water quality standard and must:

- (1) Comply with the provisions in 40 CFR section 122.47, revised as of July 1, 2014, and;
- (2) Include an enforceable final effluent limitation that is within the timeframe allowed as specified in sections 11-55-08(a)(2)(B), 11-55-15(d), 11-55-21, 11-55-22, 11-55-23(10), and 11-55-34.07(3)(B).
- (3) Require compliance as soon as possible.

(e) A schedule of compliance that exceeds one year in duration must set forth interim requirements, specific dates to meet interim requirements, and a date by which the required water quality-based effluent limitation must be achieved. [Eff and comp NOV 1 5 2014 ] Auth: HRS §§342D-4, 342D-5, 342D-53, Ch. 342E) (Imp: HRS §§342D-4, 342D-5, 342D-6, Ch. 342E)

§11-54-12 Intake credits. (a) An intake credit is an NPDES implementation tool that applies to the implementation of water quality standards through NPDES permits only.

(b) As used in this section:

"Background pollutant concentration" means the water body concentration immediately upstream/upcurrent of a permitted discharge, regardless of whether those pollutants are natural or result from anthropogenic upstream activity.

"Intake pollutant" means the background pollutant concentration that is present in the intake water body, which must be the same water body as the receiving water for the discharge at the time it is withdrawn from such waters.

"Same body of water" means an intake pollutant is considered to be from the "same body of water" as the discharge if the department finds that the intake pollutant would have reached the vicinity of the outfall point in the receiving water within a reasonable period of time had it not been removed by the permittee. This finding may be deemed established if:

- (1) The background pollutant concentration in the receiving water (excluding any amount of the pollutant in the facility's discharge) is similar to that in the intake water; and
- (2) There is a direct hydrologic connection between the intake and discharge points; and
- (3) Water quality characteristics (e.g. temperature, pH, hardness) are similar in the intake and receiving waters.

The department may consider other site-specific factors relevant to the transport and fate of the pollutant in deciding whether a pollutant would or would not have reached the vicinity of the outfall point in the receiving water within a reasonable period had it not been removed by the permittee.

(c) The director may, upon request of the discharger, adjust water quality-based effluent limitations or standards to reflect credit for intake pollutants in the discharger's intake water only:

- (1) To the extent necessary to meet the applicable limitation or standard, up to a

maximum value equal to the intake pollutant value; and

- (2) If there is no net increase in the concentration of the intake pollutant for which the credit is given. A discharger may add to the mass of the background pollutant concentration if an equal or greater mass is removed prior to discharge, so there is no net addition of the pollutant in the discharge compared to the intake water.

(d) Intake credit is not applicable to any pollutant for which a Total Maximum Daily Load (TMDL) and waste load allocation (WLA) have been developed and have been approved by the U.S. Environmental Protection Agency unless the TMDL and WLA provide for such an intake credit.

(e) The director shall grant credit for water quality-based effluent limits only if:

- (1) One hundred per cent of the intake water containing the intake pollutant is withdrawn from the same body of water into which the discharge is made;
- (2) The facility does not chemically or physically alter the intake pollutant in a manner that would cause adverse water quality impacts to occur that would not occur if the pollutant was left in-stream;
- (3) The timing and location of the discharge would not cause adverse water quality impacts to occur that would not occur if the intake pollutant were left in-stream; and,
- (4) The director finds that the discharge of intake pollutants into the same body of water will not adversely impact narrative or numeric water quality criteria specified in this chapter.

(f) Effluent limitations must be established so that they comply with all other applicable state and federal laws and regulations including water quality-based requirements and anti-degradation policies.

(g) All requests for the establishment of credit for intake pollutants shall be made on forms furnished by the department and shall be accompanied by:

- (1) Documentation showing a complete and detailed description of present conditions and how present conditions do not conform to standards; and
- (2) Documentation showing that the intake and discharge waterbodies are the "same body of water;" and
- (3) Documentation showing that pollutant(s) for which credits are being request actually come(s) from the intake water.

(h) Credit for intake pollutants shall be specified in the discharger's NPDES permit and shall become effective with the department's issuance of the permit for the specified permittee.

- (1) All permits that include intake credits issued by the department shall include monitoring of all influent, effluent, and ambient water to demonstrate that the conditions in this section are maintained during the permit term.
- (2) All credit for intake pollutants developed under this section shall be re-evaluated upon permit renewal.

(i) Credit for intake pollutants established under this section apply in the vicinity of the discharge for purposes of establishing permit limits for a specified pollutant for the specified permittee.

(j) All other water quality criteria established under this chapter continue to apply. [Eff and comp **NOV 15 2014** ] Auth: HRS §§342D-4, 342D-5, 342D-53, Ch. 342E) (Imp: HRS §§342D-4, 342D-5, 342D-6, Ch. 342E)

§11-54-13 Revision. These water quality criteria are based upon the best currently available data. Studies made in connection with the implementation program may

suggest improvements to this chapter. For this reason, the chapter will be subject to periodic review and, where necessary, to change. Any change will be made only after public hearing, held in compliance with chapter 91, HRS and the rules of practice and procedures of the department. [Eff 11/12/82; am and comp 10/6/84; am and comp 04/14/88; am and comp 01/18/90; am and comp 10/29/92, am and comp 04/17/00; am and comp 10/2/04; comp 06/15/09; comp 10/21/12; comp 12/6/13; ren §11-54-11 and comp NOV 15 2014 ] (Auth: HRS §§342D-1, 342D-4, 342D-5, Ch. 342E) (Imp: HRS §§342D-4, 342D-5, Ch. 342E)

§11-54-14 Severability. If any provisions of this chapter, or the application thereof to any person or circumstances, is held invalid, the invalidity does not affect other provisions or application of this chapter which can be given effect without the invalid provision or application, and to this end the provisions of this chapter are severable. [Eff 11/12/82; am and comp 10/6/84; am and comp 04/14/88; am and comp 01/18/90; am and comp 10/29/92, am and comp 04/17/00; am and comp 10/2/04; comp 06/15/09; comp 10/21/12; comp 12/6/13; ren §11-54-12 and comp NOV 15 2014 ] (Auth: HRS §§342D-1, 342D-4, 342D-5, Ch. 342E) (Imp: HRS §§342D-4, 342D-5, Ch. 342E)

§11-54-15 Field citations; non-compliance.  
(a) This section authorizes field citations to effectively and quickly settle easily verifiable violations of chapter 342D, HRS, and this chapter. Settlements under this section are an additional remedy and do not supplant the director's authority to issue orders under section 342D-9, HRS.

- (b) Offer to settle.
  - (1) A field citation is an offer to settle an administrative case against a specific violation on a specific day. Instead of issuing a formal notice and finding of violation and order, the director may, in the director's sole discretion, through any authorized employee, issue a field citation by personal service or certified mail to:
    - (A) Any person who discharges or otherwise causes or allows water pollutants to enter State waters and cause violation of this chapter, unless that person acted in compliance with a permit or variance issued by the director pursuant to chapter 342D for that person's discharges;
    - (B) Any person who fails to correctly install, implement, maintain, or repair site best management practices as called for in this chapter;
    - (C) Any person who violates monitoring requirements as required by the director;
    - (D) Any person who violates record keeping requirements as required by the director.
  - (2) A field citation shall indicate the following amounts for violations:
    - (A) \$500 for any person who violates paragraph (a)(1)(A), (B), or (C) for first violation, and \$2,000 for a subsequent violation; and
    - (B) \$100 for any person who violates paragraph (a)(1)(D) for first violation, and \$200 for a subsequent violation.
- (c) Resolution of field citation.
  - (1) A person issued a field citation may accept the citation by:
    - (A) Signing the field citation;



- (B) Paying the full amount indicated on the field citation. Payment shall be made to the "State of Hawaii" in the form of a pre-printed check, cashier's check, money order, or as otherwise specified by the director;
  - (C) Mailing or delivering the signed citation and full payment to the clean water branch in Honolulu or to the district health office for the county where the violation occurred. The department must receive the signed field citation and full payment within twenty days after the person receives the field citation; and
  - (D) Correction within seven (7) days, or unless otherwise specified on the field citation, of the violation of this chapter.
- (2) By signing the field citation, the person to whom it was issued agrees to:
- (A) Give up the right to a contested case hearing under chapter 91 or 342D, HRS, or otherwise challenge the field citation;
  - (B) Pay the full amount indicated; and
  - (C) Correct the violation.
- (3) If the field citation is not accepted in compliance with paragraph (1), the director may seek for that cited violation any remedies available under this chapter; chapter 342D, HRS; or any other law. For all other violations the director retains authority to seek any available remedies.
- (d) Form of citation. The department shall prescribe a field citation form." [Eff and compiled **NOV 15 2014** ] (Auth: HRS §§342D-1, 342D-4, 342D-5, Ch. 342E) (Imp: HRS §§342D-4, 342D-5, Ch. 342E)

Amendments and compilation of chapter 54, title 11, Hawaii Administrative Rules, on the Summary Page dated **NOV 15 2014** were adopted on **NOV 15 2014** following a public hearing held on October 2, 2014, after public notice was given in the Honolulu Star-Advertiser, Hawaii Tribune-Herald, West Hawaii Today, The Maui News, and The Garden Isle on August 28, 2014.

The adoption of chapter 11-54 shall take effect ten days after filing with the Office of the Lieutenant Governor

*Linda Rosen M.D.*

LINDA ROSEN, M.D.  
M.P.H.  
Director of Health

*Neil Abercrombie*

NEIL ABERCROMBIE  
Governor  
State of Hawaii

Dated: 11-5-14

Filed

APPROVED AS TO FORM:

*Edward G. Bohlen*

EDWARD G. BOHLEN  
Deputy Attorney General

54-97

14 NOV -5 P12:05

LIEUTENANT GOVERNOR'S  
OFFICE

3128



**Appendix A**

**July 1, 2014**

Class 1, Inland Waters

Hawaii

Akaka Falls State Park  
Hakalau Forest National Wildlife Refuge  
Hakalau Forest National Wildlife Refuge South Kona Section  
Hamakua Forest Reserve (Hoea Kaa Section)  
Hamakua Forest Reserve (Kainehe Section)  
Hamakua Forest Reserve (Kalopa Section)  
Hamakua Forest Reserve (Paauilo Section)  
Hapuna Beach State Recreation Area  
Hawaii Volcanoes National Park  
Hilo Forest Reserve (Humuula Section)  
Hilo Forest Reserve (Laupahoehoe Section)  
Kahaualea Natural Area Reserve  
Kalopa State Rec. Area  
Keaoi Islet Sea Bird Sanctuary  
Kekaha Kai State Park  
Kipahoehoe Natural Area Reserve  
Kohala Forest Reserve (Pololu Section)  
Kohala Historical Sites State Monument  
Kona Hema Preserve (Nature Conservancy)  
Lapakahi State Historical Park  
Laupahoehoe Natural Area Reserve  
Lava Tree State Monument  
Mackenzie State Recreation Area  
Manowaialee Forest Reserve  
Manuka Natural Area Reserve  
Manuka State Wayside  
Mauna Kea Ice Age Natural Area Reserve  
Mauna Kea State Recreation Area/Mauna Kea Fr  
Mokupuku Islet Sea Bird Sanctuary  
Ookala Cooperative Game Management Area  
Paokalani Islet Sea Bird Sanctuary  
Puu Honau O Honaunau National Historical Park  
Puu Waawaa Forest Bird Sanctuary  
Puu Waawaa Forest Reserve  
Puukohola Heiau National Historic Site  
Wailoa River State Recreation Area  
Wailuku River State Park

Kauai

Ahukini State Recreation Pier  
Haena State Park  
Hanalei National Wildlife Refuge  
Kilauea Point National Wildlife Refuge  
Kuia Natural Area Reserve  
Mokuaee Rock Islet Sea Bird Sanctuary  
Na Pali Coast State Wilderness Park  
Polihale State Park  
Russian Fort Elizabeth State Historical Park  
Wailua River State Park  
Waimea Canyon State Park  
Waimea State Recreation Pier

Lanai

Moku Naio Sea Bird Sanctuary  
Nanahoa Islets Sea Bird Sanctuary  
Poopoo Islet Sea Bird Sanctuary  
Puupehe Islet Sea Bird Sanctuary

Maui

Ahihi-Kinau Natural Area Reserve  
Alau Island Sea Bird Sanctuary  
Haleakala National Park  
Halekii-Pihana Heiaus State Monument  
Hanawi Natural Area Reserve  
Iao Valley State Monument  
Kanaha Pond Wildlife Sanctuary  
Kanaio Natural Area Reserve  
Kaumahina State Wayside  
Kealia Pond National Wildlife Refuge  
Keopuka Islet Sea Bird Sanctuary  
Makena State Park  
Mokeehia Islet Sea Bird Sanctuary  
Moku Hala Sea Bird Sanctuary  
Moku Mana Islet Sea Bird Sanctuary  
Molokini Sea Bird Sanctuary  
Papanui O Kane Islet Sea Bird Sanctuary  
Pauwalu Point Wildlife Sanctuary  
Polipoli Spring State Recreation Area

Puaa Kaa State Wayside  
Puuku Island Sea Bird Sanctuary  
Waianapanapa State Park  
Wailua Valley State Wayside  
West Maui Natural Area Reserve (Honokowai Section)  
West Maui Natural Area Reserve (Lihau Section)  
West Maui Natural Area Reserve (Panaewa Section)

Molokai

Huelo Islet Sea Bird Sanctuary  
Kakahaia National Wildlife Refuge  
Kalaupapa National Historical Park  
Kamiloloa Plant Sanctuary  
Kanaha Rock Sea Bird Sanctuary  
Mokapu Islet Sea Bird Sanctuary  
Mokumanu Islet Sea Bird Sanctuary  
Molokai Forest Reserve  
Okala Islet Sea Bird Sanctuary

Niihau

Kaula Island Sea Bird Sanctuary  
Lehua Island Sea Bird Sanctuary

Oahu

Aiea Bay State Recreation Area  
Diamond Head State Monument  
Hamakua Marsh Wildlife Sanctuary  
James Campbell National Wildlife Refuge (Kii)  
Kaohikaipu Island Sea Bird Sanctuary  
Kawainui Marsh Wildlife Sanctuary (Proposed)  
Keaiwa Heiau State Recreation Area  
Kekepa Island Sea Bird Sanctuary  
Kukaniloko Birthstones State Monument  
Kukuihoolua Island Sea Bird Sanctuary  
Makiki Valley State Recreation Area  
Malaekahana State Recreation Area  
Mokualai Island Sea Bird Sanctuary  
Mokuauia Island Sea Bird Sanctuary  
Mokulua Island Sea Bird Sanctuary  
Mokumanu Islet Sea Bird Sanctuary  
Oahu Forest National Wildlife Refuge

Chapter 11-54

Pahole Natural Area Reserve  
Paiko Lagoon Wildlife Sanctuary  
Pearl Harbor National Wildlife Refuge (Mid Loch)  
Pearl Harbor National Wildlife Refuge (W Loch)  
Pearl Harbor Nat'l Wildlife Refuge (Kalaeloa)  
Popoia Island Sea Bird Sanctuary  
Pouhala Marsh Wildlife Sanctuary  
Pulemoku Rock Sea Bird Sanctuary  
Puu Ualakaa State Park  
Royal Mausoleum State Monument  
Sacred Falls State Park  
Sand Island State Recreation Area  
Ulu Po Heiau State Monument  
Waiahole Forest Reserve (Waiahole Section)  
Waianae Kai Forest Reserve

**Appendix B**

**July 1, 2014**

Class AA, Marine Waters and Embayments

Hawaii

Puako Bay

Waiulua Bay

Anaehoomalu Bay

Kiholo Bay

Kailua Harbor

Kealakekua Bay

Honaunau Bay

Oahu

Waialua Bay

Kahana Bay

Kaneohe Bay

Hanauma Bay

Kauai

Hanalei Bay





**Appendix C**

**July 1, 2014**

Class A, Marine Waters and Embayments

Hawaii

Hilo Bay (inside breakwater)  
Kawaihae Boat Harbor  
Honokohau Boat Harbor  
Keauhou Bay

Maui

Kahului Bay  
Lahaina Boat Harbor  
Maalaea Boat Harbor

Lanai

Manele Boat Harbor  
Kaumalapau Harbor

Molokai

Hale o Lono Harbor  
Kaunakakai Harbor  
Kaunakakai Boat Harbor

Oahu

Kaiaka Bay  
Paiko Peninsula to Koko Head  
Ala Wai Boat Harbor  
Kewalo Basin  
Honolulu Harbor  
Keehi Lagoon  
Barbers Point Harbor  
Pokai Bay  
Heeia Kea Boat Harbor  
Waianae Boat Harbor  
Haleiwa Boat Harbor  
Ko Olina

Kauai

Hanamaulu Bay  
Nawiliwili Bay  
Kukuiula Bay  
Wahiawa Bay  
Hanapepe Bay (inside breakwater)  
Kikiaola Boat Harbor  
Port Allen Boat Harbor

**Appendix D**

**July 1, 2014**

Class AA, Open Coastal Waters

Measured in a clockwise direction from the first-named to the second-named location, where applicable):

Hawaii

The open coastal waters from Leleiwi Point to Waiulaula Point.

Maui

The open coastal waters between Nakalele Point and Waihee Point and between Huelo Point and Puu Olai.

Kahoolawe

All open coastal water surrounding the island.

Lanai

All open coastal waters surrounding the island.

Molokai

The open coastal waters between the westerly boundary of Hale o Lono Harbor to Lamaloa Head. Also, the open coastal waters from Cape Halawa to the easterly boundary of Kaunakakai Harbor.

Oahu

Waimanalo Bay from the southerly boundary of Kaiona Beach Park, and including the waters surrounding Manana and Kaohikaipu Islands, to Makapuu Point. Also, Waialua Bay from Kaiaka Point to Puaena Point, and the open coastal waters along Kaena Point between a distance of 5.6 kilometers (3.5 miles) from Kaena Point towards Makua and 5.6 kilometers (3.5 miles) from Kaena Point toward Mokuleia.

Kauai

The open coastal waters between Hikimoe Valley and Makahoa Point. Also, the open coastal waters between Makahuena Point and the westerly boundary of Hoai Bay.

Niihau

All open coastal waters surrounding the island.

All other islands of the state

All open coastal waters surrounding the islands not classified in Appendix D or 11-54-6(b)(2)(A).

**CHAPTER 11-55 APPENDIX F**

NPDES GENERAL PERMIT  
AUTHORIZING DISCHARGES OF HYDROTESTING WATERS

This General Permit is effective on

JUL 31 2018

and expires four years from this date,  
unless amended earlier.

1. Coverage under this General Permit
  - (a) This general permit covers facilities or activities which involve a release or discharge of hydrotesting waters to state waters. "Hydrotesting Waters" means water used to test the integrity of a tank or pipeline, water used to flush a tank or pipeline, and effluent used to disinfect a tank or pipeline.
  - (b) This general permit covers all areas of the State except for discharges into natural freshwater lakes, saline lakes, and anchialine pools.
2. Limitations on Coverage under this General Permit
  - (a) This general permit does not cover the following:
    - (1) Discharges of hydrotesting waters into a sanitary sewer system and
    - (2) Discharges of hydrotesting waters which initially enter separate storm water drainage systems, unless a permit, license, or equivalent written approval is granted by the owner(s) of the drainage system(s) allowing the subject

**CHAPTER 11-55 APPENDIX F**

discharge to enter their drainage system(s); except if the permittee is the owner of the drainage system.

- (b) The director may require any permittee authorized by this general permit to apply for and obtain an individual permit, in accordance with sections 11-55-34.05 and 11-55-34.10.

**3. Term of General Permit**

- (a) This general permit becomes effective ten days after filing with the office of the lieutenant governor.
- (b) A notice of general permit coverage under this general permit expires:
  - (1) Four years after the effective date of this general permit;
  - (2) When the notice of general permit coverage specifies; or
  - (3) When amendments to section 11-55-34.02(b)(5) are adopted,

whichever is earliest, unless the notice of general permit coverage is administratively extended under section 11-55-34.09(d).

**4. Notice of Intent Requirements**

- (a) The owner or its duly authorized representative shall submit a complete notice of intent no later than thirty days before the proposed starting date of the discharge or thirty days before the

**CHAPTER 11-55 APPENDIX F**

expiration of the applicable notice of general permit coverage.

- (b) The owner or its duly authorized representative shall include the following information in the notice of intent:
  - (1) Information required in section 34 of appendix A of chapter 11-55;
  - (2) Brief description of the project including an overview of the hydrotesting activities; an estimated timetable for major construction activities; dates on which the hydrotesting activities are projected to occur; estimated average and maximum daily flow rates; and a list of pollutants that may be present in the hydrotesting water and an explanation of its origins;
  - (3) Water quality analysis of the hydrotesting water including any toxic pollutants believed to be present in the hydrotesting water. For the hydrotesting of transmission lines, the water quality analysis for the source water may be substituted for the water quality analysis of the hydrotesting water; and
  - (4) Hydrotesting best management practices plan, including good housekeeping and mitigative measures to prevent pollutants that may be present in the hydrotesting water from entering state waters, to ensure that the hydrotesting water discharge will meet the





**CHAPTER 11-55 APPENDIX F**

conditions of this general permit, basic water quality criteria, and applicable specific water quality parameters. For discharges to Class AA or Class 1 waters, the hydrotesting best management practices plan shall be submitted with the notice of intent. For discharges to Class A or Class 2 waters, the hydrotesting best management practices plan may be submitted with the notice of intent or thirty days before the start of hydrotesting activities.

- (c) The director may require additional information to be submitted.
- (d) The owner or its duly authorized representative shall submit a complete notice of intent to the director at the following address or as otherwise specified:

Director of Health  
Clean Water Branch  
Environmental Management Division  
State Department of Health  
P.O. Box 3378  
Honolulu, Hawaii 96801-3378

**5. Standard Conditions**

The permittee shall comply with the standard conditions as specified in appendix A of chapter 11-55. In case of conflict between the conditions stated here and those specified in the standard general permit conditions, the more stringent conditions shall apply.

**CHAPTER 11-55 APPENDIX F**

6. Effluent Limitations and Monitoring Requirements for Transmission Line Testing

- (a) The water quality of the hydrotesting water shall be limited and monitored by the permittee as specified in this section and in Table 34.4. (Effluent limitations for saline water apply only when discharges to saline water occur and daily maximum effluent limitations for fresh water apply only when discharges to fresh water occur.)

(1) Sampling Point

The permittee shall collect representative discharge samples at the end of the effluent discharge point(s) prior to entering the receiving state water or separate storm water drainage systems.

(2) Collection of Samples

The permittee shall take samples and measurements for the purposes of monitoring which are representative of the volume and nature of the total discharge.

(3) Types of Samples

- (A) "Grab sample" means an individual sample collected within the first fifteen minutes of a discharge.
- (B) "Composite sample" means a combination of at least eight sample aliquots, collected at periodic intervals during the

**CHAPTER 11-55 APPENDIX F**

operating hours of the facility over a 24-hour period. The composite shall be flow proportional; either the time interval between each aliquot or the volume of each aliquot shall be proportional to the total effluent flow since the collection of the previous aliquot. The permittee may collect aliquots manually or automatically, unless otherwise stated.

(4) Test Procedures

- (A) The permittee shall use test procedures for the analysis of pollutants which conform with regulations published under Section 304(h) of the Act.
- (B) Unless otherwise noted in this general permit, the permittee shall measure all pollutant parameters in accordance with methods prescribed in 40 CFR Part 136, promulgated under Section 304(h) of the Act. The permittee may submit applications for the use of alternative test methods in accordance with 40 CFR §136.4.
- (C) The permittee shall use test methods with detection limits that reflect the applicable numerical limitations as specified in chapter 11-54 and must be sufficiently sensitive as defined at 40 CFR 122.21(e)(3) and



**CHAPTER 11-55 APPENDIX F**

122.44(i)(1)(iv). If the test result is not detectable, the permittee shall indicate that the test result is "less than #," where the # is the lowest detection limit of the test method used.

(5) Recording of Results

The permittee shall comply with section 14(c) of appendix A of chapter 11-55 for each measurement or sample taken under the requirements of this general permit.

(6) Quantity of Flow

The permittee shall estimate or calculate the quantity of hydrotesting water discharged and submit the calculations.

(b) Basic Water Quality Criteria and Inspections

- (1) The permittee shall not cause or contribute to a violation of the basic water quality criteria as specified in section 11-54-4.
- (2) The permittee shall inspect the receiving state waters, effluent, and control measures and best management practices at least once per discharge to detect violations of and conditions which may cause violations of the basic water quality criteria as specified in section 11-54-4. (e.g., the permittee shall look at effluent and receiving

**CHAPTER 11-55 APPENDIX F**

state waters for turbidity, color, floating oil and grease, floating debris and scum, materials that will settle, substances that will produce taste in the water or detectable off-flavor in fish, and inspect for items that may be toxic or harmful to human or other life.)

Note: When effluent commingles with offsite water or pollutant sources prior to discharging to the receiving water, in lieu of inspecting the receiving water, inspect the effluent after it exits the site and prior to commingling.

7. Corrective Action

The permittee shall immediately stop, reduce, or modify construction, hydrotesting, or implement new or revised best management practices as needed to stop or prevent a violation of the basic water quality criteria as specified in section 11-54-4.

8. Reporting Requirements

(a) Reporting of Monitoring Results

- (1) The permittee shall report monitoring results on a discharge monitoring report form (EPA No. 3320-1) or other form as specified by the director. The permittee shall submit results of all monitoring required by this general permit in a format that demonstrates compliance with the limitations in Table 34.4 and other requirements of this general permit.

**CHAPTER 11-55 APPENDIX F**

- (2) The permittee shall submit monitoring results obtained during the previous calendar month, postmarked or received by the department no later than the twenty-eighth day of the month following the completed reporting period.
- (3) If there is more than one discharge in a single month, report the monthly maximum, monthly minimum, and monthly average values for each parameter on the discharge monitoring report.
- (4) The permittee shall also submit the monitoring results with laboratory reports, including quality assurance/quality control data; effluent flow calculations; and any additional treatment strategies to be implemented based on monitoring results.
- (5) Should there be no discharges during the monitoring period, the discharge monitoring report form shall so state.
- (6) Discharge Monitoring Reports shall be submitted in compliance with Federal eReporting Rule requirements. Permittees shall switch from traditional paper Discharge Monitoring Reporting to electronic reporting upon written notification by the director.

(b) Monitoring Report

**CHAPTER 11-55 APPENDIX F**

The permittee shall include the monitoring results in the calculation and reporting of the values required in the discharge monitoring report form.

- (c) Reporting of Noncompliance, Unanticipated Bypass, or Upset
  - (1) The permittee or its duly authorized representative shall orally report any of the following when the permittee or its duly authorized representative becomes aware of the circumstances:
    - (A) Violation of an effluent limitation specified in Table 34.4 or a basic water quality criteria specified in section 6(b) of this general permit;
    - (B) Discharge or noncompliance with effluent limitations which may endanger health or the environment; and
    - (C) Unanticipated bypass or upset.
  - (2) The permittee shall make oral reports by telephone to the Clean Water Branch at (808) 586-4309 during regular office hours which are Monday through Friday (excluding holidays) from 7:45 a.m. until 4:15 p.m. or the Hawaii State Hospital Operator at (808) 247-2191 outside of regular office hours.
  - (3) The permittee shall provide a written report within five days of the time the



**CHAPTER 11-55 APPENDIX F**

permittee or its duly authorized representative becomes aware of the circumstances. The written report shall include the following:

- (A) Description of the noncompliance, unanticipated bypass, or upset and its cause;
  - (B) Period of noncompliance, unanticipated bypass, or upset including exact dates and times;
  - (C) Estimated time the noncompliance, unanticipated bypass, or upset is expected to continue if it has not been corrected; and
  - (D) Steps taken or planned to reduce, eliminate, and prevent reoccurrence of the noncompliance, unanticipated bypass, or upset.
- (4) The director may waive the written report on a case-by-case basis if the oral report has been received within twenty-four hours.
- (d) The permittee shall notify the director of the start of the hydrotesting activities in writing within one week before the start of the hydrotesting activities.

**9. Submittal Requirements**

- (a) The owner or its duly authorized representative shall submit signed copies of monitoring and all other reports required by this general permit to the director at the following address or as otherwise specified:

55-F-11



**CHAPTER 11-55 APPENDIX F**

Director of Health  
Clean Water Branch  
Environmental Management Division  
State Department of Health  
P.O. Box 3378  
Honolulu, HI 96801-3378

- (b) The owner or its duly authorized representative shall include the following certification statement and an original signature on each submittal in accordance with section 11-55-34.08(e) or (f):

"I certify under penalty of law that this document and all attachments were prepared under my direction or supervision in accordance with a system designed to assure that qualified personnel properly gather and evaluate the information submitted. Based on my inquiry of the person or persons who manage the system, or those persons directly responsible for gathering the information, the information submitted is, to the best of my knowledge and belief, true, accurate, and complete. I am aware that there are significant penalties for submitting false information, including the possibility of fine and imprisonment for knowing violations."

- (c) The owner or its duly authorized representative shall include the notice of general permit coverage file number on each submittal. Failure to provide the assigned notice of general permit coverage file number for this facility on future correspondence or submittals may be a basis

**CHAPTER 11-55 APPENDIX F**

for delay of the processing of the document(s).

10. Additional Conditions

The director may impose additional conditions under section 11-55-34.09(b).

11. Record Retention

The permittee shall retain all records and information resulting from the monitoring activities required by this general permit including all records of analyses performed and calibration and maintenance of instrumentation for a minimum of five years. This period of retention shall be extended during the course of any unresolved litigation or administrative enforcement action regarding the discharge of pollutants by the permittee or when requested by the director or Regional Administrator.

12. Falsifying Report

Knowingly making any false statement on any report required by this general permit may result in the imposition of criminal penalties as provided for in Section 309 of the Act and in section 342D-35, HRS.

13. Renewal

Requests for renewal of general permit coverage must be received no later than 30 calendar days before the expiration of the general permit coverage.

**CHAPTER 11-55 APPENDIX F**

14. Forms

Electronic notice of intent forms may be found at the Department's e-Permitting portal. The e-Permitting portal may be accessed via the Clean Water Branch's website at:  
<http://health.hawaii.gov/cwb/>

**CHAPTER 11-55 APPENDIX F**

TABLE 34.4

**EFFLUENT LIMITATIONS AND MONITORING REQUIREMENTS  
FOR HYDROTESTING WATER DISCHARGES**

Effluent Parameter	Effluent Limitations {1}	Minimum Monitoring Frequency	Type of Sample
Quantity of Discharge (gallons)	{2}	Once/Discharge {12}	Calculated or Estimated
Total Suspended Solids (mg/l)	{2}	Once/Discharge {12}	Grab {3}
Turbidity (NTU)	{2}	Once/Discharge {12}	Grab {3}
pH (standard units)	{4}	Once/Discharge {12}	Grab {3}, {5}
Total Residual Chlorine (µg/l) {6}	19{7} 13{8}	Once/Discharge {12}	Grab {3}
Toxic Pollutants {9}	{10}	Once/Discharge {12}	{3}, {11}

mg/l = milligrams per liter  
 µg/l = micrograms per liter  
 NTU = nephelometric turbidity units

**NOTES:**

{1} Pollutant concentration levels shall not exceed the effluent limits or be outside the ranges indicated in the table. Actual or measured levels which exceed those effluent limits or are outside those ranges shall be reported to the director as required in section 8(c) of this general permit.

**CHAPTER 11-55 APPENDIX F**

- {2} The value shall not exceed the applicable limit as specified in chapter 11-54 for the applicable classification of the receiving state waters. If no limitation is specified in chapter 11-54, then only monitoring and reporting is required.
- {3} The Permittee shall sample the discharge after dechlorination and/or filtration within the first five minutes of discharge.
- {4} The pH value shall not be outside the range as specified in chapter 11-54 for the applicable classification of the receiving state waters.
- {5} The pH shall be measured within fifteen minutes of obtaining the grab sample.
- {6} The permittee shall measure for total residual chlorine immediately after obtaining a sample and only when effluent from disinfection operations is discharged.
- {7} This limitation applies when hydrotesting water is discharged into fresh waters.
- {8} This limitation applies when hydrotesting water is discharged into saline waters.
- {9} The permittee shall measure for toxic pollutants, as identified in Appendix D of 40 CFR Part 122 or in section 11-54-4, only if they are identified as potential pollutants requiring monitoring in the notice of intent or as identified by the director. The permittee shall measure for the total recoverable portion of all metals.
- {10} Effluent limitations are the acute water quality standards established in section 11-54-4, for



**CHAPTER 11-55 APPENDIX F**

either fresh or saline waters. For pollutants which do not have established acute water quality standards, the permittee shall report any detected concentration greater than 0.01 µg/l.

- {11} The permittee shall measure for cyanide and the volatile fraction of the toxic organic compounds using a grab sample. The permittee shall measure for all other pollutants, as identified in Appendix D of 40 CFR Part 122 or in section 11-54-4 using a composite sample.
- {12} If there is more than one discharge per month in a single monitoring location, report for each parameter the monthly maximum, monthly minimum, and monthly average values on the discharge monitoring report. For pH, only report monthly minimum and monthly maximum.

13270 13

CHAPTER 11-55 APPENDIX A

DEPARTMENT OF HEALTH  
STANDARD GENERAL PERMIT CONDITIONS

DEC 06 2013

TABLE OF CONTENTS

SECTION	TITLE	PAGE
1.	Basic water quality criteria .....	55-A-2
2.	Onshore or offshore construction .....	55-A-4
3.	Sampling requirements and definitions ....	55-A-4
4.	Duty to reapply .....	55-A-14
5.	Applications .....	55-A-14
6.	Duty to comply .....	55-A-14
7.	Need to halt or reduce activity not a defense .....	55-A-14
8.	Duty to mitigate .....	55-A-14
9.	Proper operation and maintenance .....	55-A-14
10.	Permit actions .....	55-A-14
11.	Property rights .....	55-A-14
12.	Duty to provide information .....	55-A-14
13.	Inspection and entry .....	55-A-14
14.	Monitoring and records .....	55-A-15
15.	Signatory requirement .....	55-A-17
16.	Reporting requirements .....	55-A-17
17.	Bypass .....	55-A-17
18.	Upset .....	55-A-20
19.	Existing manufacturing, commercial, mining, and silvicultural dischargers .....	55-A-22
20.	Publicly owned treatment works .....	55-A-22
21.	Reopener clause .....	55-A-22
22.	Privately owned treatment works .....	55-A-22
23.	Transfers by modification .....	55-A-24
24.	Automatic transfers .....	55-A-24
25.	Minor modification of permits .....	55-A-24
26.	Termination of permits .....	55-A-24
27.	Removed substances .....	55-A-24
28.	Availability of reports .....	55-A-24

55-A-1

3270  
3085



CHAPTER 11-55 APPENDIX A

29. Civil and criminal liability ..... 55-A-25  
30. Oil and hazardous substance liability ... 55-A-25  
31. Federal facility construction ..... 55-A-25  
32. State law ..... 55-A-26  
33. Severability ..... 55-A-26  
34. Notice of Intent Requirements ..... 55-A-26

Note: All references to Title 40 of the Code of Federal Regulations (40 CFR) are to regulations that are in effect on July 1, 2012 unless otherwise specified. The Clean Water Act (Act) is also known as the Federal Water Pollution Control Act, as amended by the Clean Water Act, and appears at 33 U.S.C. §§1251 to 1387.

The permittee shall comply with the following standard conditions.

1. Basic water quality criteria (section 11-54-4)
  - a. The permittee shall not cause or contribute to a violation of the basic water quality criteria specified in section 11-54-4(a) which states:
    - "(a) All waters shall be free of substances attributable to domestic, industrial, or other controllable sources of pollutants, including:
      - (1) Materials that will settle to form objectionable sludge or bottom deposits;
      - (2) Floating debris, oil, grease, scum, or other floating materials;

**CHAPTER 11-55 APPENDIX A**

- (3) Substances in amounts sufficient to produce taste in the water or detectable off-flavor in the flesh of fish, or in amounts sufficient to produce objectionable color, turbidity or other conditions in the receiving waters;
  - (4) High or low temperatures; biocides; pathogenic organisms; toxic, radioactive, corrosive, or other deleterious substances at levels or in combinations sufficient to be toxic or harmful to human, animal, plant, or aquatic life, or in amounts sufficient to interfere with any beneficial use of the water;
  - (5) Substances or conditions or combinations thereof in concentrations which produce undesirable aquatic life; and
  - (6) Soil particles resulting from erosion on land involved in earthwork, such as the construction of public works; highways; subdivisions; recreational, commercial, or industrial developments; or the cultivation and management of agricultural lands."
- b. The discharge shall not cause or contribute to a violation of the basic requirements of section 11-54-4(b).

CHAPTER 11-55 APPENDIX A

2. Onshore or offshore construction

The applicable general permit does not authorize or approve the construction of any onshore or offshore physical structures or facilities or the undertaking of any work in any state waters.

3. Sampling requirements and definitions

(a) Sampling Points

All samples shall be taken at the monitoring points specified in the applicable general permit and, unless otherwise specified, before the effluent joins or is diluted by any other wastestream, body of water, or substance. Monitoring points shall not be changed without notification to and the approval of the director. No discharge is authorized which does not totally pass through the final monitoring point.

(b) Flow Measurements

Appropriate flow measurement devices and methods consistent with accepted scientific practices shall be selected and used to ensure the accuracy and reliability of measurements of the volume of discharges. The devices shall be installed, calibrated and maintained to ensure that the accuracy of the measurements is consistent with the accepted capability of that type of device. Devices selected shall be capable of measuring flows with a maximum deviation of less than plus or minus ten per cent from the true discharge rates throughout the range of expected discharge volumes. Once-

## CHAPTER 11-55 APPENDIX A

through condenser cooling water flow which is monitored by pump logs or pump hour meters as specified in the applicable general permit based on the manufacturer's pump curves shall not be subject to this requirement. Guidance in selection, installation, calibration, and operation of acceptable flow measurement devices can be obtained from the following references:

- (1) "A Guide of Methods and Standards for the Measurement of Water Flow," U.S. Department of Commerce, National Bureau of Standards, NBS Special Publication 421, May 1975, 97 pp. (Available from the U.S. Government Printing Office, Washington, D.C. 20402. Order by SD catalog No. C13.10:421.) (Also available from National Technical Information Service (NTIS). Order by NTIS No. COM-7510683.)
- (2) "Water Measurement Manual," U.S. Department of Interior, Bureau of Reclamation, Third Edition, Revised Reprint, 2001, 485 pp. (Available from the U.S. Government Bookstore. Order by Stock No. 024-003-00186-4 and ISBN 0-16-061763-4.) (Also available from National Technical Information Service (NTIS). Order by NTIS No. PB2002-100323.)
- (3) "Flow Measurement in Open Channels and Closed Conduits," U.S. Department of Commerce, National Bureau of Standards, NBS Special Publication 484, October 1977, 982 pp. (Available in paper copy

**CHAPTER 11-55 APPENDIX A**

or microfiche from National Technical Information Service (NTIS), Springfield, VA 22151. Order by NTIS No. PB-273 535/5ST.)

- (4) "NPDES Compliance Flow Measurement Manual," U.S. Environmental Protection Agency, Office of Water Enforcement, Publication MCD-77, EPA No. 832B81102, September 1981, 149 pp. (Available from the National Technical Information Service (NTIS). Order by NTIS No. PB82-131178.)

(c) Calibration

The permittee shall periodically calibrate and perform maintenance on all monitoring and analytical equipment used to monitor the pollutants discharged under the applicable general permit, at intervals which will ensure the accuracy of measurements, but no less than the manufacturer's recommended intervals or six-month intervals (whichever comes first). Records of calibration shall be kept under section 14.

(d) pH Effluent Limitations Under Continuous Monitoring

If the permittee continuously measures the pH of the effluent under a requirement or option in the applicable general permit, excursions from the range provided in the general permit or as specified in chapter 11-54 are permitted, provided:

CHAPTER 11-55 APPENDIX A

- (1) The pH limitation in the general permit is based upon a requirement imposed under 40 CFR Subchapter N, Effluent Guidelines and Standards;
- (2) The total time during which the pH values are outside the required range of pH values shall not exceed four hundred forty-six minutes in any calendar month;
- (3) No individual excursions from the range of pH values shall exceed sixty minutes; and
- (4) For purposes of this section, an "excursion" is an unintentional and temporary incident in which the pH value of the effluent exceeds the range set forth in the applicable general permit. The number of individual excursions exceeding sixty minutes and the total accumulated excursion time in minutes occurring in any calendar month shall be reported in accordance with the applicable general permit.

(e) Average

As used in the applicable general permit, unless otherwise stated, the term "average" means the arithmetic mean of values taken at the frequency required for each parameter over the specified period. For fecal coliform, enterococcus, or *clostridium perfringens*, the "average" shall be the geometric mean. For total coliform, the "average" shall be the median.

**CHAPTER 11-55 APPENDIX A**

(f) Mass/Day Measurements

- (1) The "daily discharge" is the total mass (weight) of a pollutant discharged during a calendar day. The daily discharge shall be determined by using the following equations:

$$\text{Daily Discharge (lbs/day)} = 8.34 \times Q \times C;$$

$$\text{Daily Discharge (kg/day)} = 3.785 \times Q \times C;$$

and

where "C" (in mg/l) is the measured daily concentration of the pollutant and "Q" (in million gallons per day) is the measured effluent flow rate for the same calendar day.

If only one sample is taken during any calendar day, the mass (weight) of pollutant discharged that is calculated from it is the "daily discharge."

- (2) The "average monthly discharge" is defined as the total mass of all daily discharges sampled or measured or both during a calendar month on which daily discharges are sampled and measured, divided by the number of daily discharges sampled or measured or both during such month. It is, therefore, an arithmetic mean found by adding the weights of the pollutant found each day of the month and then dividing this sum by the number of days. This limitation is identified as "Monthly Average" in

**CHAPTER 11-55 APPENDIX A**

the applicable general permit and the average monthly discharge value is reported in the "Average" column under "Quantity" on the discharge monitoring report form.

- (3) The "average weekly discharge" is defined as the total mass of all daily discharges sampled or measured or both during the calendar week in which daily discharges are sampled or measured or both. It is, therefore, an arithmetic mean found by adding the weights of pollutants found each day of the week and then dividing this sum by the number of days. This limitation is identified as "Weekly Average" in the applicable general permit and the average weekly discharge value is reported in the "Maximum" column under "Quantity" on the discharge monitoring report form.
- (4) The "maximum daily discharge" is the highest daily discharge value recorded, sampled, or measured during the reporting period. This limitation is identified as "Daily Maximum" in the applicable general permit and the maximum daily discharge value is reported in the "Maximum" column under "Quantity" on the discharge monitoring report form.

(g) Concentration Measurements

- (1) The "daily concentration" is the concentration of a pollutant discharged



CHAPTER 11-55 APPENDIX A

during a calendar day. It is equal to the concentration of a composite sample or in the case of grab samples, it is the arithmetic mean (weighted by flow value) of all samples collected during that calendar day. If only one sample is taken during any calendar day, it represents the "daily concentration."

- (2) The "average monthly concentration," other than for fecal coliform, enterococcus, *clostridium perfringens*, or total coliform, is the sum of the daily concentrations sampled or measured or both divided by the number of daily discharges sampled or measured or both during such month (arithmetic mean of the daily concentration values). The average monthly count for fecal coliform, enterococcus, or *clostridium perfringens* is the geometric mean of the counts for samples collected during a calendar month. The average monthly count for total coliform is the median of the counts for samples collected (not less than five discrete samples) during a calendar month. This limitation is identified as "Monthly Average" or "Daily Average" under "Other Limits" in the applicable general permit and the average monthly concentration value is reported under the "Average" column under "Quality" on the discharge monitoring report form.
- (3) The "average weekly concentration," other than for fecal coliform,

CHAPTER 11-55 APPENDIX A

enterococcus, or *clostridium perfringens*, or total coliform, is the sum of the concentrations of all daily discharges sampled or measured or both during a calendar week on which daily discharges are sampled and measured divided by the number of daily discharges sampled or measured or both during such week (arithmetic mean of the daily concentration values). The average weekly count for fecal coliform, enterococcus, or *clostridium perfringens* is the geometric mean of the counts for samples collected during a calendar week. The average weekly count for total coliform is the median of the counts for samples collected during a calendar week. This limitation is identified as "Weekly Average" under "Other Limits" in the applicable general permit and the average weekly concentration value is reported under the "Maximum" column under "Quality" on the discharge monitoring report form.

- (4) The "maximum daily concentration" is the highest daily concentration value recorded, sampled, or measured during the reporting period. This limitation identified as "Daily Maximum" under "Other Limits" in the applicable general permit and the maximum daily concentration is reported under the "Maximum" column under "Quality" on the discharge monitoring report form.

CHAPTER 11-55 APPENDIX A

- (h) The effluent flow expressed as cubic meters per day or million gallons per day (MGD), is the twenty-four-hour average flow averaged monthly. It is the arithmetic mean of the total daily flows recorded during the calendar month. Where monitoring requirements for flow are specified in the applicable general permit, the flow rate values are reported in the "Average" column under "Quantity" on the discharge monitoring report form.
- (1) An "instantaneous flow measurement" is a measure of flow taken at the time of sampling, when both the sample and flow will be representative of the total discharge.
- (2) Where monitoring requirements for pH, dissolved oxygen or fecal coliform, enterococcus, or *clostridium perfringens* are specified in the applicable general permit, the values are generally reported in the "Quality or Concentration" column on the discharge monitoring report form.
- (i) The "arithmetic mean" of any set of values is the summation of the individual values divided by the number of individual values.
- (j) The "geometric mean" of any set of values is the Nth root of the product of the individual values where N is equal to the number of individual values. The geometric mean is equivalent to the antilog of the arithmetic mean of the logarithms of the individual values. For purposes of

CHAPTER 11-55 APPENDIX A

calculating the geometric mean, values of zero shall be considered to be one.

- (k) "Weighted by flow value" means the summation of each concentration times its respective flow divided by the summation of the respective flows.
- (l) The "median" of any set of ordered values is the value below and above which there is an equal number of values or which is the arithmetic mean of the two middle values if there is no one middle number.
- (m) A calendar day is defined as the period from midnight of one day until midnight of the next day. However, for the purposes of the applicable general permit, any consecutive twenty-four-hour period that reasonably represents the calendar day may be used for sampling.
- (n) "Removal efficiency" is the ratio of pollutants removed by the treatment unit to pollutants entering the treatment unit. Removal efficiencies of a treatment plant shall be determined using the average monthly concentrations (C, in mg/l) of influent and effluent samples collected about the same time and the following equation (or its equivalent):

$$\text{Removal Efficiency} = 100 \times \left( 1 - \frac{C_{\text{effluent}}}{C_{\text{influent}}} \right)$$

(per cent)

CHAPTER 11-55 APPENDIX A

4. Duty to reapply

If the permittee wishes to continue an activity regulated by the applicable general permit after the expiration of the notice of general permit coverage or in the case of automatic coverage, the expiration of the general permit itself, the permittee shall follow the procedures as specified in sections 11-55-34.08 and 11-55-34.09.

5. Applications (comply with 40 CFR §122.22)

6. Duty to comply (comply with 40 CFR §122.41(a))

7. Need to halt or reduce activity not a defense (comply with 40 CFR §122.41(c))

8. Duty to mitigate (based in part on 40 CFR §122.41(d))

The permittee shall take all reasonable steps to minimize or prevent any discharge or sludge use or disposal in violation of the applicable general permit or applicable law.

9. Proper operation and maintenance (comply with 40 CFR §122.41(e))

10. Permit actions (comply with 40 CFR §122.41(f))

11. Property rights (comply with 40 CFR §122.41(g))

12. Duty to provide information (comply with 40 CFR §122.41(h))

13. Inspection and entry (comply with 40 CFR §122.41(i))

CHAPTER 11-55 APPENDIX A

14. Monitoring and records (based in part on 40 CFR §122.41(j))

- (a) Samples and measurements taken for the purpose of monitoring shall be representative of the monitored activity.

As used in this section, a representative sample means that the content of the sample shall:

- (1) Be identical to the content of the substance sampled at the time of the sampling;
- (2) Accurately represent the monitored item (for example, sampling to monitor final effluent quality shall accurately represent that quality, even though the sampling is done upstream of the discharge point); and
- (3) Accurately represent the monitored item for the monitored time period (for example, sampling to represent monthly average effluent flows shall be taken at times and on days that cover significant variations).  
Representative sampling may include weekends and storm events and may mean taking more samples than the minimum number specified elsewhere in the applicable general permit.  
The burden of proving that sampling or monitoring is representative is on the permittee.

CHAPTER 11-55 APPENDIX A

- (b) The permittee shall retain records of all monitoring information, including all calibration and maintenance records and all original strip chart recordings for continuous monitoring instrumentation, copies of all reports required by the applicable general permit, and records of all data used to complete the application for the applicable general permit, for a period of at least five years from the date of the sample, measurement, report or application. This period may be extended by request of the director at any time.
- (c) Records of monitoring information shall include:
- (1) The date, exact place, and time of sampling or measurements;
  - (2) The individual(s) who performed the sampling or measurements;
  - (3) The date(s) the analyses were performed;
  - (4) The individual(s) who performed the analyses;
  - (5) The analytical techniques or methods used; and
  - (6) The results of the analyses.
- (d) Monitoring must be conducted according to test procedures approved under 40 CFR Part 136 or, in the case of sludge use or disposal, approved under 40 CFR Part 136 unless otherwise specified in 40 CFR Part

CHAPTER 11-55 APPENDIX A

503, unless other test procedures have been specified in the applicable general permit.

- (e) The Act provides that any person who falsifies, tampers with, or knowingly renders inaccurate any monitoring device or method required to be maintained by the applicable general permit shall, upon conviction, be punished by a fine of not more than \$10,000 per violation, or by imprisonment for not more than two years per violation, or by both for a first conviction. For a second conviction, the person is subject to a fine of not more than \$20,000 per day of violation, or by imprisonment for not more than four years, or both. (Updated under the Water Quality Act of 1987)

15. Signatory requirement (comply with 40 CFR §§122.22 and 122.41(k))
16. Reporting requirements (comply with 40 CFR §122.41(1))
17. Bypass (based in part on 40 CFR §122.41(m))

(a) Definitions

- (1) "Bypass" means the intentional diversion of any waste streams from any portion of a treatment facility.
- (2) "Severe property damage" means substantial physical damage to property, damage to the treatment facilities which causes them to become inoperable, or substantial and



**CHAPTER 11-55 APPENDIX A**

permanent loss of natural resources which can reasonably be expected to occur in the absence of a bypass. Severe property damage does not mean economic loss caused by delays in production.

- (b) Prohibition of bypass. Every bypass is prohibited, and the director may take enforcement action against a permittee for bypass, except as provided in section 17(c).
- (c) Exceptions to bypass prohibition
  - (1) Bypass not exceeding limitations. A bypass is allowable under this paragraph only if it does not cause any effluent limitation to be exceeded, and only if the bypass is necessary for essential maintenance to assure efficient operation.
  - (2) Bypass unavoidable to prevent specified harm. A bypass is allowable under this paragraph if:
    - (A) The bypass was unavoidable to prevent loss of life, personal injury, or severe property damage;
    - (B) There were no feasible alternatives to the bypass, such as the use of auxiliary treatment facilities, retention of untreated wastes, or maintenance during normal periods of equipment downtime. This condition is not satisfied if adequate back-up

**CHAPTER 11-55 APPENDIX A**

equipment should have been installed in the exercise of reasonable engineering judgment to prevent a bypass which occurred during normal periods of equipment downtime or preventative maintenance; and

- (C) The permittee submitted notices as required under section 17(d).
- (3) Approved anticipated bypass. An anticipated bypass is allowable if the director approves it. The director shall approve the anticipated bypass only if the director receives information sufficient to show compliance with section 17(c)(2), including information on the potential adverse effects with and without the bypass, and information on the search for and the availability of alternatives, whether the permittee ultimately considers the alternatives feasible or not.
- (d) Notice
- (1) Anticipated bypass. If the permittee knows in advance of the need for a bypass, the permittee shall submit prior notice, if possible at least ten days before the date of the bypass.
- (2) Unanticipated bypass. The permittee shall report unanticipated bypasses.

CHAPTER 11-55 APPENDIX A

- (A) Reports required by the reporting requirements of the applicable general permit shall be made in accordance with that section. If the permittee questions whether the reporting requirements of the applicable general permit applies, it shall follow the reporting requirements of the applicable general permit;
- (B) For all other bypasses, reports shall be made orally within twenty-four hours from the time the permittee becomes aware of the bypass. Written reports may be required on a case-by-case basis.
- (e) Burden of proof. In any enforcement proceeding the party seeking to establish that any exception to the bypass prohibition applies has the burden of proof. Proof that effluent limitations were met requires effluent monitoring during the bypass.

18. Upset (based in part on 40 CFR §122.41(n))

- (a) Definition. "Upset" means an exceptional incident in which there is unintentional and temporary noncompliance with technology based permit effluent limitations because of factors beyond the reasonable control of the permittee. An upset does not include noncompliance to the extent caused by operational error, improperly designed treatment facilities, inadequate treatment

CHAPTER 11-55 APPENDIX A

facilities, lack of preventive maintenance, or careless or improper operation.

- (b) Effect of an upset. An upset constitutes an affirmative defense to an action brought for noncompliance with the technology based permit effluent limitations if the requirements of section 18(c) are met. No determination made during administrative review of claims that noncompliance was caused by upset, and before an action for noncompliance, is final administrative action subject to judicial review.
- (c) Conditions necessary for a demonstration of upset. A permittee who wishes to establish the affirmative defense of upset shall demonstrate, through properly signed, contemporaneous operating logs, or other relevant evidence that:
  - (1) An upset occurred and that the permittee can identify the cause(s) of the upset;
  - (2) The permitted facility was at the time being properly operated;
  - (3) The permittee submitted within twenty-four hours a notice of any upset which exceeded any effluent limitation in the applicable general permit; and
  - (4) The permittee complied with any remedial measures required under 40 CFR §122.41(d).

55-A-21

3270

30 85

CHAPTER 11-55 APPENDIX A

- d. Burden of proof. In any enforcement proceeding, any person seeking to establish the occurrence of an upset has the burden of proof.
19. Existing manufacturing, commercial, mining, and silvicultural dischargers (comply with 40 CFR §122.42(a))
20. Publicly owned treatment works (comply with 40 CFR §122.42(b))
21. Reopener clause (comply with 40 CFR §122.44(c) and 40 CFR §125.123(d)(4))
22. Privately owned treatment works (The following conditions were established by EPA Region 9 to enforce applicable requirements of the Resource Conservation and Recovery Act and 40 CFR §122.44(m))

This section applies only to privately owned treatment works as defined at 40 CFR §122.2.

- (a) Materials authorized to be disposed of into the privately owned treatment works and collection system are typical domestic sewage. Unauthorized materials are hazardous waste (as defined at 40 CFR Part 261), motor oil, gasoline, paints, varnishes, solvents, pesticides, fertilizers, industrial wastes, or other materials not generally associated with toilet flushing or personal hygiene, laundry, or food preparation, unless specifically listed under "Authorized Non-domestic Sewer Dischargers" elsewhere in the applicable general permit. The Domestic

55-A-22

**CHAPTER 11-55 APPENDIX A**

Sewage Exclusion (40 CFR §261.4) does not apply to hazardous wastes mixed with domestic sewage in a sewer leading to a privately owned treatment works.

- (b) It is the permittee's responsibility to inform users of the privately owned treatment works and collection system of the prohibition against unauthorized materials and to ensure compliance with the prohibition. The permittee must have the authority and capability to sample all discharges to the collection system, including any from septic haulers or other unsewered dischargers, and shall take and analyze such samples for conventional, toxic, or hazardous pollutants when instructed by the permitting authority or by an EPA or state inspector. The permittee must provide adequate security to prevent unauthorized discharges to the collection system.
- (c) Should a user of the privately owned treatment works desire authorization to discharge non-domestic wastes, the permittee shall submit a request for permit modification and an application, under 40 CFR §122.44(m), describing the proposed discharge. The application shall, to the extent possible, be submitted using forms provided by the Administrator, unless another format is requested by the permitting authority. If the privately owned treatment works or collection system user is different from the permittee, and the permittee agrees to allow the non-domestic discharge, the user shall submit

**CHAPTER 11-55 APPENDIX A**

the application and the permittee shall submit the applicable general permit modification request. The application and request for modification shall be submitted at least six months before authorization to discharge non-domestic wastes to the privately owned treatment works or collection system is desired.

23. Transfers by modification (comply with 40 CFR §122.61(a))
24. Automatic transfers (comply with 40 CFR §122.61(b) and section 11-55-34.08(i)(2))
25. Minor modification of permits (comply with 40 CFR §122.63)
26. Termination of permits (comply with 40 CFR §122.64)
27. Removed substances (under Sections 301 and 405 of the Act and 40 CFR §125.3(g))

Solids, sludges, filter backwash, or other pollutants removed in the course of treatment or control of wastewaters shall be disposed of in a manner which prevents any pollutant from the materials from entering state waters.

28. Availability of reports (under Section 308 of the Act)

Except for data determined to be confidential under 40 CFR Part 2, all reports prepared in accordance with the terms of the applicable general permit shall be available for public inspection at the offices of the director. As required by the Act, permit applications,

**CHAPTER 11-55 APPENDIX A**

permits, and effluent data shall not be considered confidential.

29. Civil and criminal liability (under Section 309 of the Act)

Except as provided in the applicable general permit conditions on "Bypass" (section 17) and "Upset" (section 18), nothing in the applicable general permit shall be construed to relieve the permittee from civil or criminal penalties or remedies for noncompliance.

30. Oil and hazardous substance liability (under Section 311 of the Act)

Nothing in the applicable general permit shall be construed to preclude the institution of any legal action or relieve the permittee from any responsibilities, liabilities, or penalties to which the permittee is or may be subject under Section 311 of the Act.

31. Federal facility construction (under Section 313(b) of the Act)

Construction shall not be initiated for facilities for treatment of wastewater at any federal property or facility if alternative methods for wastewater treatment at the property or facility utilizing innovative treatment processes and techniques, including, but not limited to, methods utilizing recycle and reuse techniques and land treatment are not utilized, unless the life cycle cost of the alternative treatment works exceeds the life cycle cost of the most effective alternative by more than fifteen per cent.



**CHAPTER 11-55 APPENDIX A**

32. State law (under Section 510 of the Act)

Nothing in the applicable general permit shall be construed to preclude the institution of any legal action or relieve the permittee from any responsibilities, liabilities, or penalties established under any applicable state law or regulation.

33. Severability (under Section 512 of the Act)

The provisions of the applicable general permit are severable and if any provision of the applicable general permit, or the application of any provision of the applicable general permit to any circumstance, is held invalid, the application of the provision to other circumstances, and the remainder of the applicable general permit, shall not be affected thereby.

34. Notice of Intent Requirements (comply with section 11-55-34.08)

The owner or its duly authorized representative shall include the following information in the notice of intent (NOI):

- (a) Legal name(s), street address, contact person's name and position title, and telephone and email address of the owner, operator, except for Appendix C and duly authorized representative, if applicable;

Note: For a construction activity, the operator is usually the general contractor.

- (b) Ownership status as federal, state, private, public or other entity;

CHAPTER 11-55 APPENDIX A

- (c) Name, street address, island, tax map key number(s), contact person's name and position title, and telephone and email address of the facility or project for which the notice of intent is submitted;
- (d) Name(s) of the receiving state water(s) that the effluent enters or will enter, the latitude and longitude of each outfall or discharge point to the nearest receiving state water(s), and the classification of the receiving state water(s).

If the effluent initially enters a separate storm water drainage system, the owner or its duly authorized representative shall provide the following information:

- (1) Name of the owner of the drainage system; and
  - (2) Copy of the permit, license, or equivalent written approval granted by the owner(s) of the drainage system(s) allowing the subject discharge to enter their drainage system(s).
- (e) Type of general permit required for the proposed discharge;
  - (f) Quantity of discharge; the source of the discharge; and the period of discharge, i.e., continuous, seasonal, occasional, or emergency;
  - (g) Topographic map or maps of the area extending at least one mile beyond the property boundaries of the site which clearly show the following:

**CHAPTER 11-55 APPENDIX A**

- (1) Legal boundaries of the site;
  - (2) Location and an identification number for each of the site's existing and proposed intake and discharge structures; and
  - (3) Receiving state water(s) or receiving storm water drainage system(s) identified and labeled. If the receiving state water is a wetland, submit a map showing the delineated wetland.
- (h) Flow chart or line drawing showing the general route taken by the discharge from the intake or source to the discharge point, except for Appendices B, C, and K. The owner or its duly authorized representative shall show any treatment system(s) or erosion control(s) used or to be used for new discharges. The flow contributed by each source may be estimated if no data is available;
- (i) List of existing or pending permits, licenses, or approvals and corresponding file numbers; and
- (j) Certifying person's name and position title, company name, and telephone and fax numbers.

# LETTER OF TRANSMITTAL

**DISABILITY AND COMMUNICATION  
ACCESS BOARD  
1010 Richards Street,  
Room 118  
Honolulu, Hawaii 96813**

**(808) 586-8104  
Fax # 586-8129**

To:  
**County of Kauai  
4398 Pua Loke Street  
Lihue, Hawaii 96766**


DATE	July 24, 2018	DCAB #	2018-400
ATTENTION	Eric Fujikawa		
RE	Rehabilitate Paua Valley Tank No. 1 0.5MG Concrete Kekaha Water System		

WE ARE SENDING YOU (\*) Attached the following items:

COPIES	DATE	NO	DESCRIPTION
1	July 24, 2018	1 page	Document Review

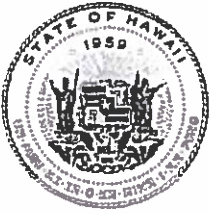
THESE ARE TRANSMITTED as checked below:

- Transmitted via facsimile
- Transmitted via email [efujikawa@kauaiwater.org](mailto:efujikawa@kauaiwater.org)
- Drawings and/or specifications returned to consultant/department

SIGNED   
Duane Buote  
Facility Access Coordinator

cc via email:

Daryl Yokomizo  
Kai Hawaii, Inc.  
50 South Beretania Street  
Honolulu, Hawaii 96813  
[dyokomizo@kaihawaii.com](mailto:dyokomizo@kaihawaii.com)



## DISABILITY AND COMMUNICATION ACCESS BOARD

1010 Richards Street, Room 118 • Honolulu, Hawaii 96813  
Ph. (808) 586-8121 (V) • (808) 586-8162 (TTY) • Fax (808) 586-8129

### DOCUMENT REVIEW

July 24, 2018

#### **Rehabilitate Paua Valley Tank No. 1 0.5MG Concrete Kekaha Water System**

DCAB Job #: 2018-400  
Project #: 17-10 WP2020 Project No. KW-07  
Department/Agency: County of Kauai  
Eric Fujikawa  
Design Firm: Kai Hawaii, Inc.  
Daryl Yokomizo  
Documents Reviewed: 6 sheets of subject project received July 2, 2018  
Specifications received - n/a  
Document transmittal Form dated July 2, 2018  
Previous Review(s): n/a

The documents submitted do not indicate any construction requiring the application of the 2004 Americans with Disabilities Act Accessibility Guidelines (2004 ADAAG) and other applicable design standards, as required by Hawaii Revised Statutes (HRS) 103-50.

The above constitutes review and recommendations on this project to determine whether or not the building or facility is designed in accordance with the 2004 ADAAG and other applicable design standards, per HRS 103-50. Final responsibility to comply with HRS 103-50 rests with the State or County agency overseeing the project.

Reviewed by:

Duane Buote  
Facility Access Coordinator

cc via email:

Daryl Yokomizo  
Kai Hawaii, Inc.

**CWB NOI Form**

version 1.5

(Submission #: HNH-RE2M-VNM3V, version 2)

PRINTED ON 10/23/2018

**Summary**

<b>Submission #:</b>	HNH-RE2M-VNM3V	<b>Date Submitted:</b>	10/23/2018 3:52 PM
<b>Form:</b>	CWB NOI Form	<b>Status:</b>	Submitted
<b>Submitted By:</b>	Eunjin Kotkovetz	<b>Submission Creator:</b>	Eunjin Kotkovetz
<b>Active Steps:</b>	Assign To		
<b>File/Reference #:</b>		<b>Reference #:</b>	
<b>Description:</b>	CWB NOI Form		

**Notes**

There are currently no Submission Notes.

**Details****1a. NOI Requirements**

I certify: I have read HAR, Chapters 11-54 and 11-55. I understand that State law prohibits any water pollutant to be discharged to a State water except in compliance with HAR, Chapters 11-54 and 11-55. I understand that the NPDES General Permits are a privilege and not my right or entitlement. I understand that the NPDES General Permits are rules, not permits to be issued. I understand that the NPDES General Permits only authorize a specific discharge/activity when I comply with all conditions of the NPDES General Permit. I have read every condition of the NPDES General Permit I am requesting coverage under. I have determined that my project/activity and organization can, and will, comply with every condition of the applicable NPDES General Permit, and any and all legal obligations. I understand that I may only submit the NOI after determining that my project/activity and organization can, and will, comply with every condition of the applicable NPDES General Permit. I understand that if I cannot comply with any condition of the NPDES General Permit I need to either fix my organization so that I can comply or I cannot discharge water pollutants to State waters. I understand that the Notice of General Permit Coverage (NGPC) is not a permit; it is an authorization to comply with the already issued NPDES General Permit.

Yes.

NPDES general permits cannot cover "after the fact" discharges/activities. You are required to certify below that the information provided in this NOI does not include "after the fact" discharges/activities.

I certify that the information provided in this NOI does not contain "after the fact" discharges/activities.

You are required to report any discharges/activities associated with your project/facility that started before obtaining NPDES permit coverage. This only applies to discharges to State waters and activities that require NPDES permit coverage [e.g. construction activities that disturb one (1) acre or more]. Please select one (1) of the options below.

I did not start any discharges/activities associated with my project/facility.

I certify under penalty of law that my proposed discharge will not impair any State waters (including but not limited to rivers, streams, wetlands, ponds, ground waters, and ocean), Native Hawaiian cultural resources (including but not limited to burial sites/iwi, heiau, and taro loi), or the exercise of traditional Native Hawaiian cultural practices.

Yes, I certify.

If you answered No above, describe the step(s) you will take to reasonably protect those State waters, Native Hawaiian resources, or exercise of traditional Native Hawaiian cultural practices. Please only include the steps that have been accepted by the Office of Hawaiian Affairs and other appropriate agencies. Note: It is your responsibility under the Constitution of the State of Hawaii to mitigate any impacts.

NONE PROVIDED

## 1b. Emergency-Related Construction Activities

I am conducting earth-disturbing activities in response to a public emergency that meets the eligibility requirements under HAR, Chapter 11-55, Appendix C, Sections 1.3 and 7.2.3.

No. This section does not apply to me.

Please state the cause of the public emergency (e.g. natural disaster, extreme flooding conditions, etc.).

NONE PROVIDED

Please describe the construction necessary to reestablish the affected public service.

NONE PROVIDED

Official Emergency Declaration - Attachment

NONE PROVIDED

Comment: NONE PROVIDED

Please complete the remaining sections of this form (Sections 2 through 9). Pursuant to HAR 11-55, Appendix C, you are automatically covered under the NPDES General Permit Authorizing Discharges of Storm Water Associated with Construction Activities if you submit the completed form through the e-Permitting Portal, pay the required filing fee, and submit the Transmittal Requirements and Certification Statement for e-Permitting Notice of Intent (NOI) Submission form within 30 calendar days after the start of construction activities for an official emergency declaration. You may immediately commence with your emergency-related construction activities provided that you comply with all other applicable laws and regulations.

## 2. Owner Information

### Owner Legal Name

County of Kauai

### Owner Department

Department of Water

### Owner Division

Engineering Division

### Owner Mailing Address

4398 Pua Loke Street  
Lihue, HI 96766-1600

### Owner's Street Address

4398 Pua Loke Street  
Lihue, HI 96766-1600

### Owner Type

Municipal - City, County, or State Government Project

### Signatory Type

The person certifying this NOI must meet one of the following descriptions and be employed by the Owner. Please identify your appropriate signatory type based on the items listed below.

State Agency: I certify that for a state agency, I am a principal executive officer or ranking elected official.

Municipal Agency: I certify that for a municipal agency, I am a principal executive officer or ranking elected official.

Non-Federal Public Agency: I certify that for a non-federal public agency, I am a principal executive officer or ranking elected official.

Federal Agency: I certify that for a federal agency, I am the chief executive officer of the agency, or I am the senior executive officer having responsibility for the overall operations of a principal geographic unit of the agency.

Partnership: I certify that I am a general partner for a partnership.

Proprietorship: I certify that I am the proprietor for a sole proprietorship.

Corporation Officer: I certify that for a corporation, I am the President, Vice President, Secretary, or Treasurer of the corporation and in charge of a principal business function, or I perform similar policy or decision-making functions for the corporation.

Corporation Manager: I certify that for a corporation, I am the Manager of one or more manufacturing, production, or operating facilities and am authorized to make management decisions which govern the operation of the regulated facility or facilities including having the explicit or implicit duty of making major capital investment recommendations, and initiating and directing other comprehensive measures to assure long term environmental compliance with environmental laws and regulations. I can ensure that the necessary systems are established or actions taken to gather complete and accurate information for permit application requirements and authority to sign documents has been assigned or delegated to me in accordance with corporate procedures.

Trust: I certify that for a trust, I am a trustee.

LLC: I certify that for a limited liability company (LLC), I am the Manager or a Member authorized to make management decisions for the LLC and am in charge of a principal business function, or I perform similar policy or decisionmaking functions for the LLC.

**Please Select the Signatory Type based on the above descriptions.**

Municipal Agency

**Certifying Person Salutation**

Mr.

**Certifying Person First Name**

Bryan

**Certifying Person Last Name**

Wienand

**Certifying Person Title**

Manager and Chief Engineer

**Certifying Person Email Address**

BWienand@kauaiwater.org

**Certifying Person Phone Number (e.g., 555-555-5555)**

808-245-5408

**Certifying Person Alternate Phone Number (cell) (e.g., 555-555-5555)**

808-245-5400

**Certifying Person Fax Number (e.g., 555-555-5555)**

808-245-5813

The Owner's contact person may be the staff person with direct responsibility for the facility or project, not necessarily the certifying or "responsible" person.

**Owner Contact Person's Salutation**

Mr.

**Owner Contact Person's First Name**

Eric

**Owner Contact Person's Last Name**



Fujikawa

**Owner Contact Person's Position Title**

Civil Engineer

**Owner Contact Person's Email**

efujikawa@kauaiwater.org

**Owner Contact Person's Phone number (e.g., 555-555-5555)**

808-245-5412

**Owner Contact Person's Alternate Phone Number (cell) (e.g., 555-555-5555)**

808-245-5400

**Owner Contact Person's Fax number (e.g., 555-555-5555)**

808-245-5813

**3. Operator or General Contractor Contact Information**

Will Operator or General Contractor information be submitted at least 30 calendar days before the start of construction activities? If you are requesting coverage under HAR 11-55, Appendix C, do not provide the General Contractor information in this section. Include this information in your SWPPP before the start of construction.

Yes. (I will provide operator/general contractor information 30 calendar days prior to discharge.)

**Operator/General Contractor Legal name**

NONE PROVIDED

**Operator/General Contractor Department**

NONE PROVIDED

**Operator/General Contractor Division**

NONE PROVIDED

**Operator/General Contractor Mailing address**

NONE PROVIDED

**Operator/General Contractor Street address:**

NONE PROVIDED

**Operator/General Contractor Contact Person's Salutation**

NONE PROVIDED

**Operator/General Contractor Contact Person's First Name**

NONE PROVIDED

**Operator/General Contractor Contact Person's Last Name**

NONE PROVIDED

**Operator/General Contractor Contact Person's Position Title**

NONE PROVIDED

**Operator/General Contractor Contact Person's Email**

NONE PROVIDED

**Operator/General Contractor Contact Person's Phone number (e.g., 555-555-5555)**

NONE PROVIDED

**Operator/General Contractor Contact Person's Alternate Phone Number (cell) (e.g., 555-555-5555)**

NONE PROVIDED

**Operator/General Contractor Contact Person's Fax number (e.g., 555-555-5555)**

NONE PROVIDED

#### 4. Facility/Project Information

Enter the Facility or Project Name

The Facility or Project Name will appear on all correspondence, official files, and permits.

**Facility or Project Name**

Job No. 17-10, WP2020 Project No. KW-07, Rehabilitate Paua Valley Tank No. 1, 0.5 MG Concrete Kekaha Water System, Kekah Kauai Hawaii

Provide the Mailing Address

The mailing address may be the mailing address of the facility's or project's contact person.

Mailing Address

4398 Pua Loke Street  
Lihue, HI 96766-1600

Provide the Street Address

The street address is the facility or project location with respect to identifiable street names or adjacent developments or properties (i.e., 1234 15th Drive or northwest corner of 1st Street and X Avenue).

**Street Address (i.e. the location of the project or facility)**

Kekaha Water System, Kekah, Kauai Hawaii

Provide the Facility/Project Contact Person information.

Provide the facility/project contact person information. The facility/project contact person can be anyone (e.g. consultant, staff, etc.).

**Facility/Project Contact Person Salutation**

Mr.

**Facility/Project Contact Person's First Name**

Eric

**Facility/Project Contact Person's Last Name**

Fujikawa

**Facility/Project Contact Person's Title**

Civil Engineer

**Facility/Project Contact Person's Email**

efujikawa@kauaiwater.org

**Facility/Project Contact Person Phone Number (e.g., 555-555-5555)**

808-245-5412

**Facility/Project Contact Person Alternate Phone Number (cell) (e.g., 555-555-5555)**

808-245-5400

**Facility/Project Contact Person Fax Number (e.g., 555-555-5555)**

808-245-5813

**Facility/Project Front Gate Location Coordinates or Start of Linear Construction Location Coordinates**

21.98302992594584,-159.7104301811823

#### 5. Tax Map Key (TMK) No.

Facility/Project Tax Map Key (TMK) Number(s)

You are required to download and complete the TMK spreadsheet below. All TMK numbers involved in the facility/project need to be disclosed. A minimum of one (1) TMK is required.

[TMK Spreadsheet](#)

**Upload Completed TMK Spreadsheet - Attachment**[TMK-NOI-Kekaha Tank 1.xlsx - 10/22/2018 01:32 PM](#)

Comment:

**6. Receiving State Water(s) Information (1 of 1)**

HAR, Section 11-54-1 defines State waters as: All waters, fresh, brackish, or salt around and within the State, including, but not limited to, coastal waters, streams, rivers, drainage ditches, ponds, reservoirs, canals, and lakes; provided that drainage ditches, ponds, and reservoirs required as part of a water pollution control system are excluded. This chapter applies to all state waters, including wetlands, subject to the following exceptions: (1) This chapter does not apply to groundwater. (2) This chapter does not apply to ditches, flumes, ponds and reservoirs that are required as part of a water pollution control system. (3) This chapter does not apply to ditches, flumes, ponds, and reservoirs that are used solely for irrigation and do not overflow into any other state waters, unless such ditches, flumes, ponds, and reservoirs are waters of the United States as defined at 40 C.F.R. 122.2.

A receiving State water is the first State water that receives the discharge. Note: You must identify a receiving State Water before an NGPC can be issued. Identify the receiving State water name in relation to the facility or project site based on the topography or contours of the land, excluding evaporation, percolation, retention, detention, etc. The receiving State water must be a surface water. Sample responses for this item include: Pacific Ocean at Sandy Beach, Honolulu Harbor, Pearl Harbor, Aiea Stream, Unnamed Stream Kaloi Gulch, Unnamed Dry Gulch, Unnamed Wetlands, etc.

**Receiving State Waters Name**

Paua Valley

Select the receiving State water CLASSIFICATION:

Classifications are defined in HAR, Chapter 11-54 and on the Water Quality Standards Maps available on the CWB website. The Water Quality Standards Maps are provided for general information only and are to be used in conjunction with HAR, Chapter 11-54. Click on the link below to download a copy of HAR, Chapter 11-54.

[HAR, Chapter 11-54](#)

The Water Quality Standards Maps can be found by clicking on the link below.

[Water Quality Standards Maps](#)**Receiving State Water Classification**

Class 2, Inland

**Coordinates of the Discharge Point into State waters**

Provide the coordinates of the discharge point (in decimal degrees) where discharge from the facility or construction site first enters the receiving State water. If the discharge first enters a storm drainage system, provide the discharge point coordinates for the outfall where the storm drainage system enters State waters. If the storm water discharge enters the receiving State water as a sheet flow, provide the coordinates based on the limits of discharge. For Example: Type: Discharge Point 1 (From) Latitude 21.274685 N, Longitude 158.012768 W (Click the "+" button in the tab heading row above to enter the next location) Then type: Discharge Point 1 (To) Latitude 21.304811N, Longitude 158.022721 W

Properly label the discharge points with numbers (i.e., Discharge Point No. 1, Discharge Point No. 2, etc.) which correspond to the location map(s) and flow chart(s) submitted.

**Discharge Point label**

Discharge Point 1

**Discharge Point**

21.98302795451226,-159.71036786358695

Is the receiving State water on the Section 303(d) List?

Click on the link below to view the Section 303(d) List.

[Section 303\(d\) List](#)

Is the receiving State water on the Section 303(d) List?

No

If your Receiving Water is on the Section 303(d) List, please provide the impairment pollutant(s).

NONE PROVIDED

Are there additional discharge points into receiving State waters?

No

If YES was selected, click the "+" button in the tab area at the top of this section to describe additional discharge points into receiving State waters.

## 7. Receiving Drainage System(s) Information (1 of 1)

Does the discharge enter a STORMWATER DRAINAGE SYSTEM before discharging into the receiving State waters?

No

If YES selected, provide the information for ALL of the following questions in this section.

**Drainage System Owner's Name**

NONE PROVIDED

**Drainage System Owner's Approval**

Please submit the Drainage System owner's approval to allow the subject discharge to enter their Drainage System. If the project owner also owns the Drainage System, you do not have to submit the approval. If you are requesting coverage under HAR 11-55, Appendix C, do not attach the approval. Instead, include the approval in your SWPPP before the start of construction.

**Drainage System Owner's Approval to Discharge - Attachment**

NONE PROVIDED

Comment: NONE PROVIDED

Please note that if you did not attach the Drainage System Owner's Approval to this application, you are required to submit the Approval to Discharge at least 30 calendar days before the start of discharge.

**Will Drainage System Owner's approval be submitted at least 30 calendar days before start of discharge?**

NONE PROVIDED

**If the Drainage System Owner is the same as the Owner of this Project, please select one of the following.**

NONE PROVIDED

**Are there additional Drainage Systems that may receive stormwater runoff from the project?**

NONE PROVIDED

If YES was selected, click the "+" button in the tab area at the top of this section to provide additional Receiving Drainage System information.

## 8. Authorized Representative

**Authorization**

The Certifying Person hereby authorizes the named individual or any individual occupying the named position of the company/organization listed below to act as our representative to submit information/documents necessary to complete the NOI to discharge to State waters from the subject facility. Our representative is further authorized to submit information/documents for compliance with the NPDES general permit conditions, except submittal of the Notice of Cessation (NOC). The Owner hereby agrees to comply with and be responsible for all NPDES general permit conditions. This authorization begins with NOI processing and ends upon receipt of the NOC by the CWB. The Owner authorizes the duly authorized representative to submit additional information/documents necessary to complete the NOI and to submit information/documents to comply with the NPDES general permit conditions. The Owner is responsible for all information/documents submitted by the duly authorized representative for completion of the NOI and for compliance with the NPDES general permit conditions. The Certifying Person is required to sign the NOC for the project. After receipt of the NOC for the project, the duly authorized representative is no longer

recognized by the CWB. The responsibility of the authorized representative cannot be delegated to an outside consultant with no financial responsibility for the company - they cannot sign as the "authorized representative" on behalf of the Owner. This requirement stems from the fact that self-reporting is critical under the Clean Water Act and Hawaii Water Pollution statutes; reports filed with CWB can have serious legal consequences, including possible civil and even criminal liability. The Owner in signing reports, therefore, must be represented by someone who has some responsibility for the corporation's financial interests. The Certifying Person attests that the authorized representative 1) meets the requirements of HAR 11-55-07(b); and 2) has financial responsibility within the corporation/organization who can attest to the accuracy of reports either because he or she participated in the preparation of the report, or supervises those who did prepare it and can attest that those individuals followed standard protocols that ensure the accuracy of the report. Both the Certifying Person and authorized representative understand that they can be subject to civil and criminal liability for non-compliance with NPDES general permit conditions, non-compliance with HAR Chapters 11-54 and 11-55, and for falsifying information.

#### Authorized Representative Contact Information

Complete the following for your Authorized Representative.

**Authorized Representative Company/Organization Name**

County of Kauai

**Authorized Representative Department**

Department of Water

**Authorized Representative Division**

Engineering Division

**Authorized Representative Mailing Address**

4398 Pua Loke Street  
Lihue, HI 96766-1600

**Authorized Representative Street Address**

4398 Pua Loke Street  
Lihue, HI 96766-1600

**Authorized Representative First Name**

Eric

**Authorized Representative Salutation**

Mr.

**Authorized Representative Last Name**

Fujikawa

**Authorized Representative Email Address**

efujikawa@kauaiwater.org

**Authorized Representative Phone (e.g., 555-555-5555)**

808-245-5412

**Authorized Representative Alternate Phone (cell) (e.g., 555-555-5555)**

808-245-5400

**Authorized Representative Fax (e.g., 555-555-5555)**

808-245-5813

### 9. Discharge Specific Attachments

a. Please select the NPDES general permit you are requesting coverage under. You may only request coverage under one (1) NPDES general permit per e-Permitting submission.

Appendix F - Discharges of hydrotesting waters.

b. Download and complete appropriate form(s).

For the NPDES general permit you are requesting coverage under (Section 9.a above), please download and complete the appropriate NOI form (Section 9.d below).

**c. Upload completed form(s). - Attachment(s)**

[Kauai DOW\\_Kekaha\\_NOI\\_F\\_22Oct2018.pdf - 10/22/2018 02:23 PM](#)

Comment:

**d. NOI forms.**

Please see below for all of the NOI forms. A description of the discharge/activity is provided. Click on the link to download the form.

NOI Form B - Discharges of storm water associated with industrial activities. NPDES permit coverage is required for discharges of storm water runoff associated with industrial activity(ies), as categorized in 40 CFR 122.26(b)(14)(i) through 122.26(b)(14)(ix) and 122.26(b)(14)(xi).

[Click on this link to download NOI Form B.](#)

NOI Form C - Discharges of storm water associated with construction activities. NPDES permit coverage is required for activities that disturb one (1) acre or more of total land area. NPDES permit coverage is also required for activities that disturb less than one (1) acre of total land area that are part of a larger common plan of development or sale if the larger common plan will ultimately disturb one (1) acre or more of total land area [40 CFR 122.26(b)(15)]. Land disturbance includes, but is not limited to clearing, grubbing, grading, excavation, demolition (even if leaving foundation), uprooting of vegetation, equipment staging on grassed areas or bare ground, equipment staging on a paved roadway (only if area blocked off from public usage), storage areas, and roadway work that touches the base course. Note: Areas which are cleared, graded, and/or excavated for the sole purpose of growing crops are considered to be agricultural and are therefore not included in the disturbed area quantity. This exemption does not extend to the construction of buildings and roads of agricultural or agriculture-related operations that disturb one (1) acre or more.

[Click on this link to download NOI Form C.](#)

NOI Form D - Discharges of treated effluent from leaking underground storage tank remedial activities. NPDES permit coverage is required for the release or discharge of treated ground water to State waters from the cleanup (or remedial action) of underground storage tanks that have leaked petroleum hydrocarbons.

[Click on this link to download NOI Form D.](#)

NOI Form E - Discharges of once through cooling water less than (1) million gallons per day. NPDES permit coverage is required for discharges to State waters of once through cooling water with a total flow of less than one (1) million gallons per day. "once through cooling water" means water passed through the main cooling condensers one or two times for the purpose of removing waste heat.

[Click on this link to download NOI Form E.](#)

NOI Form F - Discharges of hydrotesting waters. NPDES permit coverage is required for the release or discharge of hydrotesting waters to State waters. "Hydrotesting Waters" means water used to test the integrity of a tank or pipeline, pipeline disinfection, and/or pipeline flushing.

[Click on this link to download NOI Form F.](#)

NOI Form G - Discharges of construction activity dewatering. NPDES permit coverage is required for discharges to State waters of construction activity dewatering effluent. "Dewatering Effluent" is any type of water (e.g. ground water, storm water, stream water, ocean water, etc.) pumped from a construction area.

[Click on this link to download NOI Form G.](#)

NOI Form H - Discharges of treated process wastewater associated with petroleum bulk stations and terminals. NPDES permit coverage is required for discharges to State waters of treated process wastewater effluent from petroleum bulk stations and terminals. Treated process wastewater effluent includes tank water draws, product displacement process wastewater, wash down and fire hydrant system test waters, service station tank draws, recovered groundwater, and contaminated storm water runoff from the product storage and handling areas.

[Click on this link to download NOI Form H.](#)

NOI Form I - Discharges of treated process wastewater associated with well drilling activities. NPDES permit coverage is required for discharges to State waters of treated process wastewater associated with well drilling activities. Treated process wastewater includes well drilling slurries, lubricating fluids wastewaters, and well purge wastewaters.

[Click on this link to download NOI Form I.](#)

NOI Form K - Discharges of storm water and certain non-storm water discharges from small Municipal Separate Storm Sewer Systems (MS4s). NPDES permit coverage is required for storm water and certain non-storm water discharges to State waters from small MS4s.

[Click on this link to download NOI Form K.](#)

NOI Form L - Discharges of circulation water from decorative ponds or tanks. NPDES permit coverage is required for discharges to State waters of circulation water from decorative ponds or tanks containing fish or other aquatic species.

[Click on this link to download NOI Form L.](#)

**Attachments**

Date	Attachment Name	Context	Confidential?
10/22/2018 02:23 PM	Kauai DOW_Kekaha_NOI_F_22Oct2018.pdf	v2 - 9. Discharge Specific Attachments	No <input type="checkbox"/>
10/22/2018 01:32 PM	TMK-NOI-Kekaha Tank 1.xlsx	v2 - 5. Tax Map Key (TMK) No.	No <input type="checkbox"/>

**Status History**

Date	User	Processing Status
10/23/2018 3:47:09 PM	Eunjin Kotkovetz	Draft
10/23/2018 3:52:10 PM	Eunjin Kotkovetz	Submitted

**Processing Steps**

Step Name	Assigned To/Completed By	Date Completed
Application Submitted	Eunjin Kotkovetz	10/23/2018 03:52 PM
Assign To		
In Review		
Issue NGPC		



State of Hawaii, Department of Health, Clean Water Branch

NOI Form F

NOI for HAR, Chapter 11-55, Appendix F - NPDES General Permit  
Authorizing Discharges of Hydrotesting Waters

All sections of this form **MUST** be completed for National Pollutant Discharge Elimination System (NPDES) General Permit compliance.

### **F.1 – General Information**

You are required to fulfill all requirements and check the box below. If you do not check the box, your NOI will be considered incomplete, and the CWB may deny your request for NPDES general permit coverage with prejudice.

I certify that:

- I will design, implement, operate, and maintain a Hydrotesting Best Management Practices (BMPs) Plan to ensure that my discharges of hydrotesting waters will not violate HAR, Chapter 11-54; HAR, Chapter 11-55; and HAR, Chapter 11-55, Appendix F.
- My Hydrotesting BMPs Plan shall include good housekeeping practices to prevent the introduction of pollutants to the hydrotesting effluent; mitigative measures (i.e., filtration system, dechlorination method, etc.) which will be installed to prevent pollutants that may be present in the hydrotesting effluent from entering the receiving State waters; and will contain appropriate measures to address Section 303(d) pollutants of concern for my receiving State water.
- Prior to any discharge of hydrotesting effluent, I will provide treatment to remove all pollutants of concern identified in Sections F.6, F.7, and F.8.

### **F.2 – Maps**

Attach, title, and identify all maps (pdf - minimum 300 dpi) listed below, in Attachment E. Please reference which maps account for the features listed below.

- a. Island on which the activity is located. Kauai (Figure 1 and Figure 2)
- b. Location(s) of activity. Figures 3 and Figure 4. Kekaha 0.5 MG Water Reservoir, Kekaha, Kauai 96752. There are two water reservoirs on site. Reservoir No. 1 will be repaired and hydrotested.
- c. Topographic map or maps which clearly show the legal boundaries of the activity; location of all existing and/or proposed outfalls or discharge points; and receiving State water(s) and receiving storm water drainage system(s), if applicable, identified and labeled. Figure 2 and Figure 3. The hydrotesting water will be discharged into Paua Valley for infiltration. The coordinate of discharge point is at 426665.95 m E, 2431120.46 m N.



- d. Location of the tank, waterlines and/or sewer lines to be hydrotested. Figure 4
- e. Location of permit compliance sampling point(s). Top and bottom of water from Reservoir No.1 to be hydrotested.

*Note: You are required to specify the monitoring points where samples will be taken to demonstrate permit compliance. All samples will be taken before the effluent joins or is diluted by any other wastestream, body of water, or substance. No discharge is authorized which does not totally pass through the final monitoring point. If the permit is issued, monitoring points shall not be changed without notification to and the approval of the Director of Health.*

### **F.3 – Flow Chart or Line Drawing**

Attach or insert in Attachment A, a flow chart showing the following (Check each item, as applicable): Find Figure 5.

- a. General route taken by hydrotesting water through the project or activity from intake to the discharge point
- b. Structures to be hydrotested
- c. Hydrotesting Best Management Practices (BMPs) utilized (e.g., dechlorination, filtration, etc.)
- d. Estimated quantity of flow through each applicable route from upslope to the receiving State water
- e. Drainage system(s) receiving hydrotesting effluent, as applicable (e.g., City and County of Honolulu Municipal Separate Storm Sewer System (MS4), etc.)
- f. State water name(s) receiving hydrotesting effluent

Indicate which item(s) are not identified and explain why the item(s) are not identified None.

### **F.4 - Existing or Pending Permits, Licenses, or Approvals**

Place a check next to all applicable Federal, State, or County permits, Licenses, or approvals for the project and specify the permit number.

- Other NPDES Permit or NGPC File No.: N/A
- Department of the Army Permit (Section 404): N/A
- If your project requires work in, above, under or adjacent to State waters, please contact the Army Corps of Engineers (COE) Regulatory Branch at (808) 438-9258 regarding their permitting requirements. Provide a copy of the COE permitting jurisdictional determination (JD) or the JD with COE Person's Name, Phone Number, and Date Contacted.*
- Facility on SARA 313 List (identify SARA 313 chemicals on project site): N/A
- RCRA Permit (Hazardous Wastes): N/A
- Section 401 Water Quality Certification: N/A
- Other (Specify): Risk-Based Polychlorinated Biphenyls (PCB) Removal Action under Toxic Substance Control Act (TSCA) 761.61 (c). Find Attachment G for the Discharge Work Plan (18

September 2018) and Attachment H for the Conditional Approval Letter from the US EPA (16 October 2018).

**Discharging Water:** During the 2017 assessment of the condition of the Reservoir No. 1, the water in the reservoir was drained and suspected hazardous material samples were collected from the interior and exterior of the reservoir. Samples of the coal tar lining at the interior floor and walls, and wall base joint sealant were taken and tested, and the results turned out positive for PCB up to 283 milligrams per kilogram (mg/kg). Subsequent to the initial assessment and after the reservoir had been refilled, an oily layer was found floating on the surface of the water. Samples of the oily layer was taken and also had been tested positive for PCB. The PCB concentration of the oily layer was 13 micrograms per liter (µg/L) exceeding the EPA's Maximum Contaminant Level (MCL), 0.5 µg/L. Currently, the reservoir contains approximately 0.35 MG of water. Discharge of PCB contaminated water in the reservoir and PCB encapsulation of existing coating material of the reservoir will be conducted in accordance with the Work Plan that was conditionally approved from the USEPA.

**PCB-Impacted Soil Management:** The PCB-impacted waters from the tank were discharged to Paua Valley as needed for overflow control or to provide interior tank access. A Soil PCB investigation was conducted in 2018 to evaluate the presence of PCB-contaminated soil exceeding the HDOH Tier 1 Environmental Action Levels (EAL) in the Paua Valley. Total PCB was 3.9 mg/kg in the Decision Unit 1 (DU1), exceeding the Tier 1 EAL of 1.2 mg/kg. DU 1 encompassed the immediate effluent outlet and extended approximately 12 feet across laterally, as applicable, and went east from the headwall to the drainage ditch, turned toward southwest and downstream; the DU length was approximately 100 feet. Find Attachment I for the Soil PCB Investigation Report. The EPA's letter dated 16 October 2018 indicates remediation of PCB impacted soil will be required. The County of Kauai, Department of Water (DOW) will work closely with the US EPA to address soil remediation or removal in DU1 and will take necessary actions upon the decision is made.

The EPA's regulator is Ms. Sara Ziff. and the contact information is as below:

Sara Ziff, P.E / Project Manager  
Corrective Action Section  
U.S. Environmental Protection Agency, Region 9  
75 Hawthorne Street (LND-4-1)  
San Francisco, California 94105  
(415) 972-3536  
ziff.sara@epa.gov

### ***F.5 – Activity Description***

a. *Provide an overview or describe the hydrotesting activities.*

The DOW, and its selected contractor will proceed the Reservoir No. 1 Rehabilitation Project, which includes interior and exterior work. There are three major works as follows:

1. Discharge PCB-Containing Water from Reservoir No. 1 (approximately 0.35 MG). Find Attachment D for the discharge plan and Attachment G Work Plan that was submitted to

the US EPA. Please note that Attachment D is a plan summarizing Attachment G. The PCB-containing water may be discharged between July – September 2019.

2. Tank repair. The repair plan/drawing is provided in Attachment E.
  - a. Repair all concrete spalls and cracks, then, apply new paint/coating materials to all painted surfaces.
  - b. The existing PCB containing coating materials (reservoir interior) will be encapsulated with new coating material.
3. Conduct tank cleaning and perform hydrotesting and disinfection. In order to confirm that the water in the reservoir is acceptable for potable use, the Contractor will collect two (2) water samples from the reservoir to test coliforms and PCBs. Find Attachment D for discharge plan and Best Management Plans (BMPs).

The selected Contractor may revise or modify the plan and submit the final plan/updated plan at least 30 days before the start of discharging. The Contractor will be required to install silt fences for erosion control during construction as presented in Appendix E, Reservoir Repair Plan, Drawing R-1, Reservoir Repair Site Plan.

- b. *Provide the estimated date when construction will begin.* June 2019
- c. *Provide the estimated date when construction will end.* July 2020
- d. *Provide the estimated date when hydrotesting activities will begin.* June 2020
- e. *Provide the estimated date when hydrotesting activities will end.* July 2020
- f. *Provide the estimated average daily flow rates.* 14,000 gpd
- g. *Provide the estimated maximum daily flow rates.* 14,000 gpd
- h. *Provide the estimated total quantity of discharge.* 850,000 gallons (350,000 gallons of PCB contaminated water + 500,000 gallons of hydrotesting water). PCB contaminated water (350,000 gallons) will be discharged between July – September 2019.

**F.6 – Physical Hydrotesting Water Quality**

- a. Provide the source(s) of hydrotesting water  
 (i.e. BWS Kunia well, Nuuanu Reservoir, etc.) Kekaha-Waimea Water System, Kauia Department of Water. The water will be coming from Kekaha Waipao Valley Well and Kekaha Paua Valley Well. Find Attachment B. Water Quality Report.
- b. Is the source of hydrotesting water potable?  
 Yes       No
- c. Place an “x” in either the “Believe Present” column or the “Believe Absent” column based on the test results or your best estimate.

Parameter	Believe Present	Believe Absent
Floating Debris		X
Scum or Foam		X
Color		X
Odor		X

List the Discharge Point(s) that you identified in Section 6 of the e-Permitting CWB NOI Form B Through I, K, and L that apply to this table There is a discharge point [426665.95 m E, 2431120.46 m N] to Paua Valley as presented in Figure 4.

Please ensure that all Discharge Points are accounted for. If you leave this item blank, we will assume that this table applies to all Discharge Points. If needed, you may copy, paste, and complete this table for each Discharge Point with different test results.

**F.7 – Water Quality Parameters**

You are required to fulfill all requirements in F.7.a or F.7.b below.

- a. The source of hydrotesting water is **potable**, and I have attached the water quality analysis from the source water treatment/distribution operator (i.e. Board of Water Supply, County Department of Water, etc.) in Attachment B. I acknowledge that no further testing of the source water is necessary, and I will not complete Table F.7 below. **The Water Quality Report form Kauai Department Water is provided in Attachment B.**
- b. The source of hydrotesting water is **non-potable**. Please fulfill the requirements and check the box below. If you do not check the box, your NOI will be considered incomplete, and the CWB may deny your request for NPDES general permit coverage with prejudice.

I certify that:

- *I tested all of the parameters in the Table F.7 below, and a copy of the laboratory data sheets with Quality Assurance/Quality Control and Chain of Custody documents is included in Attachment B. I am reporting the results of my test in Table F.7 below.*
- *All test results were obtained from a representative sample as defined in HAR, Chapter 11-55, Appendix A, Section 14(a). Note: The burden of proving that sampling or monitoring is representative is on the Permittee.*
- *The test methods that I utilized were promulgated in 40 CFR Part 136 and, when applicable, listed in the references of chemical methodology for seawater analyses (see HAR, Chapter 11-54, Section 10(b)). Note: If a test method has not been promulgated for a particular parameter, you may apply for approval of an alternate test procedure by following 40 CFR Section 136.4.*
- *The test methods that I utilized have detection limits below and closest to the numerical limit specified in HAR, Chapter 11-54 and are sufficiently sensitive as defined at 40 CFR 122.21(e)(3). For situations where the numerical limitation is below the detection limit of the test methods, I used the test method which has the detection limit closest to the numerical limitation.*

c. Complete Table F.7 below if the hydrotesting source water is **non-potable**. The test results shall be reported to the nearest decimal place or whole number as shown in the parentheses following each parameter. For example, "Temperature (0.1 °C)" - Temperature shall be reported to the nearest tenth of a centigrade and "Ammonia Nitrogen (1 µg/l)" - Ammonia Nitrogen shall be reported to the nearest whole microgram per liter. One test result may be reported for Salinity, Chloride, or Conductivity. If the test result is not detectable, indicate that the test result is "N.D." or "not detected."

**Table F.7**

Parameter	Test Result	Units
Turbidity (0.1 NTU)		NTU
Total Suspended Solids (1 mg/l)		mg/l
pH (0.1 standard units)		standard units
Dissolved Oxygen (0.1 mg/l)		mg/l
Oxygen Saturation (1%)		%
Temperature (0.1 °C)		°C
Salinity (0.1 ppt)		ppt
or Chloride (0.1 mg/l)*		mg/l
or Conductivity (1 µmhos/cm)*		µmhos/cm
Oil and Grease (1 mg/l)		mg/l

\* Fresh waters and effluent samples

List the Discharge Point(s) that you identified in Section 6 of the e-Permitting CWB Individual NPDES Form that apply to Table F.7. [426665.95 m E, 2431120.46 m N] to Paua Valley

Please ensure that all Discharge Points are accounted for. If you leave this item blank, we will assume Table F.7 applies to all Discharge Points. If needed, you may copy, paste, and complete Table F.7 for each Discharge Point with different test results.

### F.8 – Toxic Parameters

- a. You are required to fulfill all requirements and check the box below if the hydrotesting source water is **non-potable**. If you do not check the box, your application will be considered incomplete, and the CWB may deny your request for NPDES general permit coverage with prejudice.

I certify that:

- I tested and I am reporting (in micrograms per liter) all of the parameters which are believed to be present in the hydrotesting water in Tables F.8.a to F.8.h below. Note: As an example, if the tank previously contained a petroleum product, you should expect that petroleum product to be present in the hydrotesting waters.
- For all test results that were not detectable, I indicated "N.D." or "not detected" in the "Test Result" column of Tables F.8.a to F.8.h.
- For all parameters not believed to be present, I indicated "N/A" for "not applicable" in the "Test Result" column of Tables F.8.a to F.8.h.
- If the "Test Result" columns of Tables F.8.a to F.8.h are left blank, the CWB will consider these parameters to be present. The NGPC will require all of these parameters to be monitored.
- A copy of the laboratory data sheets with Quality Assurance/Quality Control and Chain of Custody documents, are included in Attachment B.
- All test results were obtained from a representative sample as defined in HAR, Chapter 11-55, Appendix A, Section 14(a). Note: The burden of proving that sampling or monitoring is representative is on the Permittee.
- The test methods that I utilized were promulgated in 40 CFR Part 136 and, when applicable, listed in the references of chemical methodology for seawater analyses (see HAR, Chapter 11-54, Section 10(b)). Note: If a test method has not been promulgated for a particular parameter, you may apply for approval of an alternate test procedure by following 40 CFR Section 136.4.
- The test methods that I utilized have detection limits below and closest to the numerical limit specified in HAR, Chapter 11-54 and are sufficiently sensitive as defined at 40 CFR 122.21(e)(3). For situations where the numerical limitation is below the detection limit of the test methods, I used the test method which has the detection limit closest to the numerical limitation.

- b. Complete Tables F.8.a to F.8.h below if the hydrotesting source water is **non-potable**. The parameters are categorized into Metals, Organonitrogen Compounds, Pesticides,

*Phenols, Phthalates, Polynuclear Aromatic Hydrocarbons, Volatile Organics, and Others and are listed alphabetically. A Glossary of Chemicals is listed in Attachment C.*

*List the Discharge Point(s) that you identified in Section 6 of the e-Permitting CWB NOI Form that apply to Tables F.8.a to F.8.h.* \_\_\_\_\_

*Please ensure that all Discharge Points are accounted for. If you leave this item blank, we will assume Tables F.8.a to F.8.h applies to all Discharge Points. If needed, you may copy, paste, and complete Tables F.8.a to F.8.h for each Discharge Point with different test results.*

**Table F.8.a - Metals**

<i>Total Recoverable Metal Parameter</i>	<i>Test Result</i>	<i>Units</i>
<i>Aluminum</i>		<i>µg/l</i>
<i>Antimony</i>		<i>µg/l</i>
<i>Arsenic</i>		<i>µg/l</i>
<i>Beryllium</i>		<i>µg/l</i>
<i>Cadmium</i>		<i>µg/l</i>
<i>Chromium (VI)</i>		<i>µg/l</i>
<i>Copper</i>		<i>µg/l</i>
<i>Lead</i>		<i>µg/l</i>
<i>Mercury</i>		<i>µg/l</i>
<i>Nickel</i>		<i>µg/l</i>
<i>Selenium</i>		<i>µg/l</i>
<i>Silver</i>		<i>µg/l</i>
<i>Thallium</i>		<i>µg/l</i>
<i>Tributyltin</i>		<i>µg/l</i>
<i>Zinc</i>		<i>µg/l</i>

**Table F.8.b. - Organonitrogen Compounds**

<i>Organonitrogen Compound Parameter</i>	<i>Test Result</i>	<i>Units</i>
<i>Benzidine</i>		<i>µg/l</i>
<i>2,4-Dinitro-o-cresol</i>		<i>µg/l</i>
<i>Dinitrotoluenes</i>		<i>µg/l</i>
<i>1,2-Diphenylhydrazine</i>		<i>µg/l</i>
<i>Nitrobenzene</i>		<i>µg/l</i>
<i>Nitrosamines</i>		<i>µg/l</i>
<i>N-Nitrosodibutylamine</i>		<i>µg/l</i>
<i>N-Nitrosodiethylamine</i>		<i>µg/l</i>
<i>N-Nitrosodimethylamine</i>		<i>µg/l</i>
<i>N-Nitrosodiphenylamine</i>		<i>µg/l</i>
<i>N-Nitrosopyrrolidine</i>		<i>µg/l</i>

**Table F.8.c. - Pesticides**

<i>Pesticide Parameter</i>	<i>Test Result</i>	<i>Units</i>
<i>Aldrin</i>		$\mu\text{g/l}$
<i>Chlordane</i>		$\mu\text{g/l}$
<i>Chlorpyrifos</i>		$\mu\text{g/l}$
<i>DDT</i>		$\mu\text{g/l}$
<i>Demeton</i>		$\mu\text{g/l}$
<i>Dieldrin</i>		$\mu\text{g/l}$
<i>Endosulfan</i>		$\mu\text{g/l}$
<i>Endrin</i>		$\mu\text{g/l}$
<i>Guthion</i>		$\mu\text{g/l}$
<i>Heptachlor</i>		$\mu\text{g/l}$
<i>Lindane</i>		$\mu\text{g/l}$
<i>Malathion</i>		$\mu\text{g/l}$
<i>Methoxychlor</i>		$\mu\text{g/l}$
<i>Mirex</i>		$\mu\text{g/l}$
<i>Parathion</i>		$\mu\text{g/l}$
<i>TDE - metabolite of DDT</i>		$\mu\text{g/l}$
<i>Toxaphene</i>		$\mu\text{g/l}$

**Table F.8.d. - Phenols**

<i>Phenol Parameter</i>	<i>Test Result</i>	<i>Units</i>
<i>2-Chlorophenol</i>		$\mu\text{g/l}$
<i>2,4-Dichlorophenol</i>		$\mu\text{g/l}$
<i>2,4-Dimethylphenol</i>		$\mu\text{g/l}$
<i>Nitrophenols</i>		$\mu\text{g/l}$
<i>Pentachlorophenol</i>		$\mu\text{g/l}$
<i>Phenol</i>		$\mu\text{g/l}$
<i>2,3,5,6-Tetrachlorophenol</i>		$\mu\text{g/l}$
<i>2,4,6-Trichlorophenol</i>		$\mu\text{g/l}$

**Table F.8.e. - Phthalates**

<i>Phthalate Parameter</i>	<i>Test Result</i>	<i>Units</i>
<i>Bis (2-ethylhexyl) phthalate</i>		$\mu\text{g/l}$
<i>Dibutyl phthalate (esters)</i>		$\mu\text{g/l}$
<i>Diethyl phthalate (esters)</i>		$\mu\text{g/l}$
<i>Dimethyl phthalate (esters)</i>		$\mu\text{g/l}$



**Table F.8.f. - Polynuclear Aromatic Hydrocarbons**

<i>Polynuclear Aromatic Hydrocarbon Parameter</i>	<i>Test Result</i>	<i>Units</i>
<i>Acenaphthene</i>		$\mu\text{g/l}$
<i>Fluoranthene</i>		$\mu\text{g/l}$
<i>Naphthalene</i>		$\mu\text{g/l}$
<i>Polynuclear aromatic hydrocarbons</i>		$\mu\text{g/l}$

**Table F.8.g. - Volatile Organics**

<i>Volatile Organic Parameter</i>	<i>Test Result</i>	<i>Units</i>
<i>Acrolein</i>		$\mu\text{g/l}$
<i>Acrylonitrile</i>		$\mu\text{g/l}$
<i>Benzene</i>		$\mu\text{g/l}$
<i>Carbon tetrachloride</i>		$\mu\text{g/l}$
<i>Bis(2-chloroethyl)ether</i>		$\mu\text{g/l}$
<i>Bis(chloroethers-methyl)</i>		$\mu\text{g/l}$
<i>Bis(chloroisopropyl)ether</i>		$\mu\text{g/l}$
<i>Chloroform</i>		$\mu\text{g/l}$
<i>Dichlorobenzenes</i>		$\mu\text{g/l}$
<i>Dichlorobenzidine</i>		$\mu\text{g/l}$
<i>1,2-Dichloroethane</i>		$\mu\text{g/l}$
<i>1,1-Dichloroethylene</i>		$\mu\text{g/l}$
<i>Dichloropropanes</i>		$\mu\text{g/l}$
<i>1,3-Dichloropropene</i>		$\mu\text{g/l}$
<i>Ethylbenzene</i>		$\mu\text{g/l}$
<i>Hexachlorobenzene</i>		$\mu\text{g/l}$
<i>Hexachlorobutadiene</i>		$\mu\text{g/l}$
<i>Hexachlorocyclohexane, alpha</i>		$\mu\text{g/l}$
<i>Hexachlorocyclohexane, beta</i>		$\mu\text{g/l}$
<i>Hexachlorocyclohexane, technical</i>		$\mu\text{g/l}$
<i>Hexachlorocyclopentadiene</i>		$\mu\text{g/l}$
<i>Hexachloroethane</i>		$\mu\text{g/l}$
<i>Isophorone</i>		$\mu\text{g/l}$
<i>Pentachlorobenzene</i>		$\mu\text{g/l}$
<i>Pentachloroethanes</i>		$\mu\text{g/l}$
<i>1,2,4,5-Tetrachlorobenzene</i>		$\mu\text{g/l}$
<i>1,1,2,2-Tetrachloroethane</i>		$\mu\text{g/l}$
<i>Tetrachloroethanes</i>		$\mu\text{g/l}$
<i>Tetrachloroethylene</i>		$\mu\text{g/l}$

---

<i>Volatile Organic Parameter</i>	<i>Test Result</i>	<i>Units</i>
<i>Toluene</i>		$\mu\text{g/l}$
<i>1,1,1-Trichloroethane</i>		$\mu\text{g/l}$
<i>1,1,2-Trichloroethane</i>		$\mu\text{g/l}$
<i>Trichloroethylene</i>		$\mu\text{g/l}$
<i>Vinyl chloride</i>		$\mu\text{g/l}$

**Table F.8.h. - Others**

<i>Other Parameter</i>	<i>Test Result</i>	<i>Units</i>
<i>Chlorine</i>		$\mu\text{g/l}$
<i>Cyanide</i>		$\mu\text{g/l}$
<i>Dioxin</i>		$\mu\text{g/l}$
<i>Polychlorinated biphenyls</i>		$\mu\text{g/l}$

### **F.9 – Hydrotesting Best Management Practices (BMPs) Plan**

You are responsible for the design, implementation, operation, and maintenance of the Hydrotesting BMPs Plan to ensure that discharges of hydrotesting waters will not cause or contribute to a violation of HAR, Chapter 11-54, Chapter 11-55, and Chapter 11-55 Appendix F.

- a.  My discharge **will enter Class AA or Class 1 waters.** I have attached my Hydrotesting BMPs Plan that complies with Section F.1. It is included in Attachment D.
- b.  My discharge will enter Class A or Class 2 waters.
- I have attached my Hydrotesting BMPs Plan that complies with Section F.1. It is included in Attachment D.
- I will submit my Hydrotesting BMPs Plan at least 30 days before the start of hydrotesting activities. **By not submitting my Hydrotesting BMPs Plan with my NOI, I acknowledge that:**
- The CWB may not provide comments on information in Section F.9.
  - I am required to submit Section F.9 to the DOH-CWB for comment at least 30 calendar days prior to starting hydrotesting activities. All questions/concerns that the DOH may have must be answered to the satisfaction of the CWB.
  - The CWB will review Section F.9 in the order received and will not expedite the review to accommodate my schedule.
  - The CWB has no required time limits to review any Hydrotesting BMPs Plan after issuance of an NGPC.
  - I am potentially exposing myself to significant delays.

### **F.10 – Additional Information**

Include any other site-specific information pertaining to the project or activity in Attachment E. If nothing is included in Attachment E, the CWB will assume you do not want to include additional information.

**Attachment A – Maps and Flow Chart (Sections F.2 and F.3)**

*MAPS AND FLOW CHART*

*Figure 1. Site Location Map*

*Figure 2. Topographic Map*

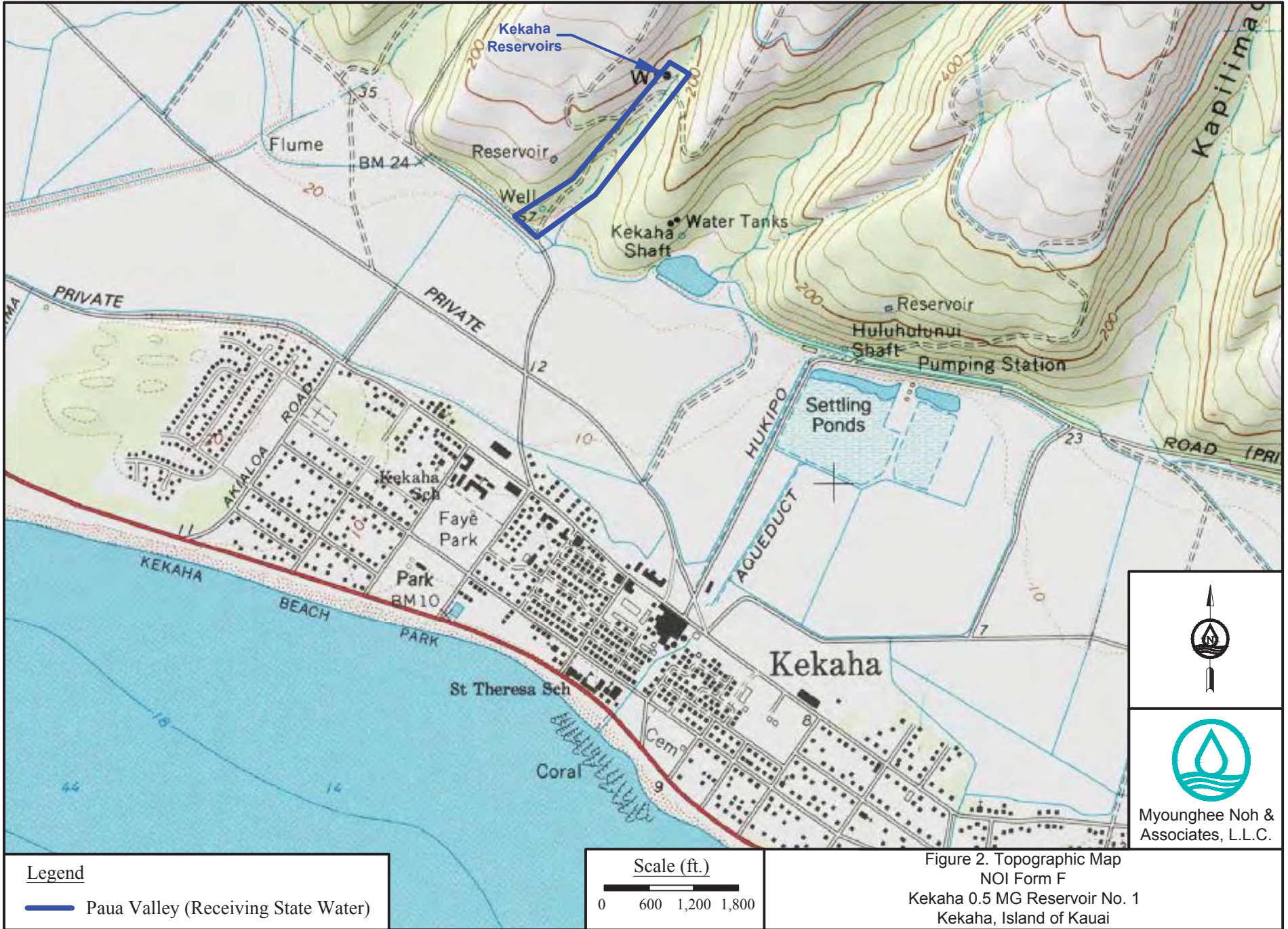
*Figure 3. Google Earth Aerial View of Receiving State Water*

*Figure 4. Google Earth Aerial View of Discharge Point*

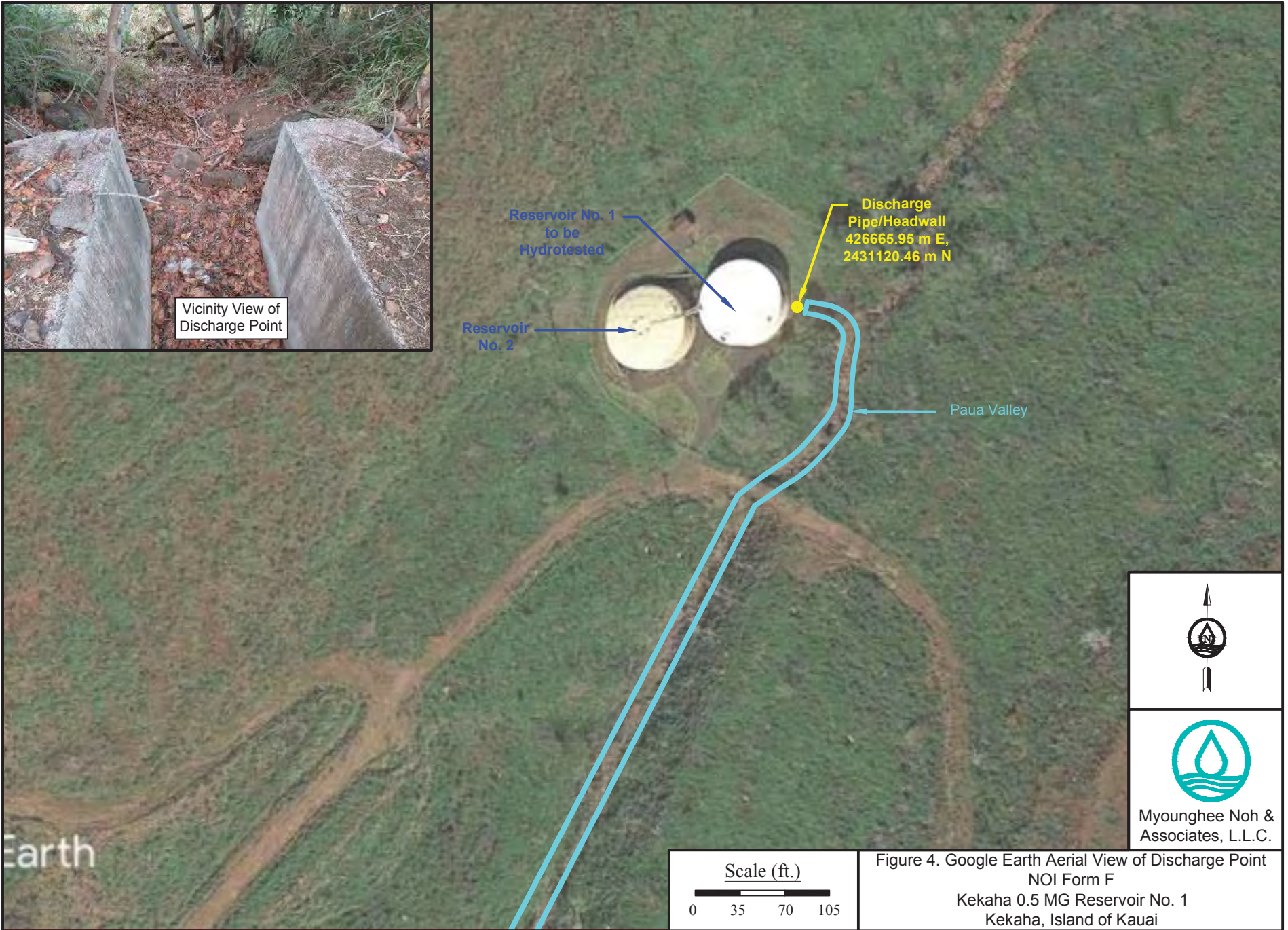
*Figure 5. Flow Chart*



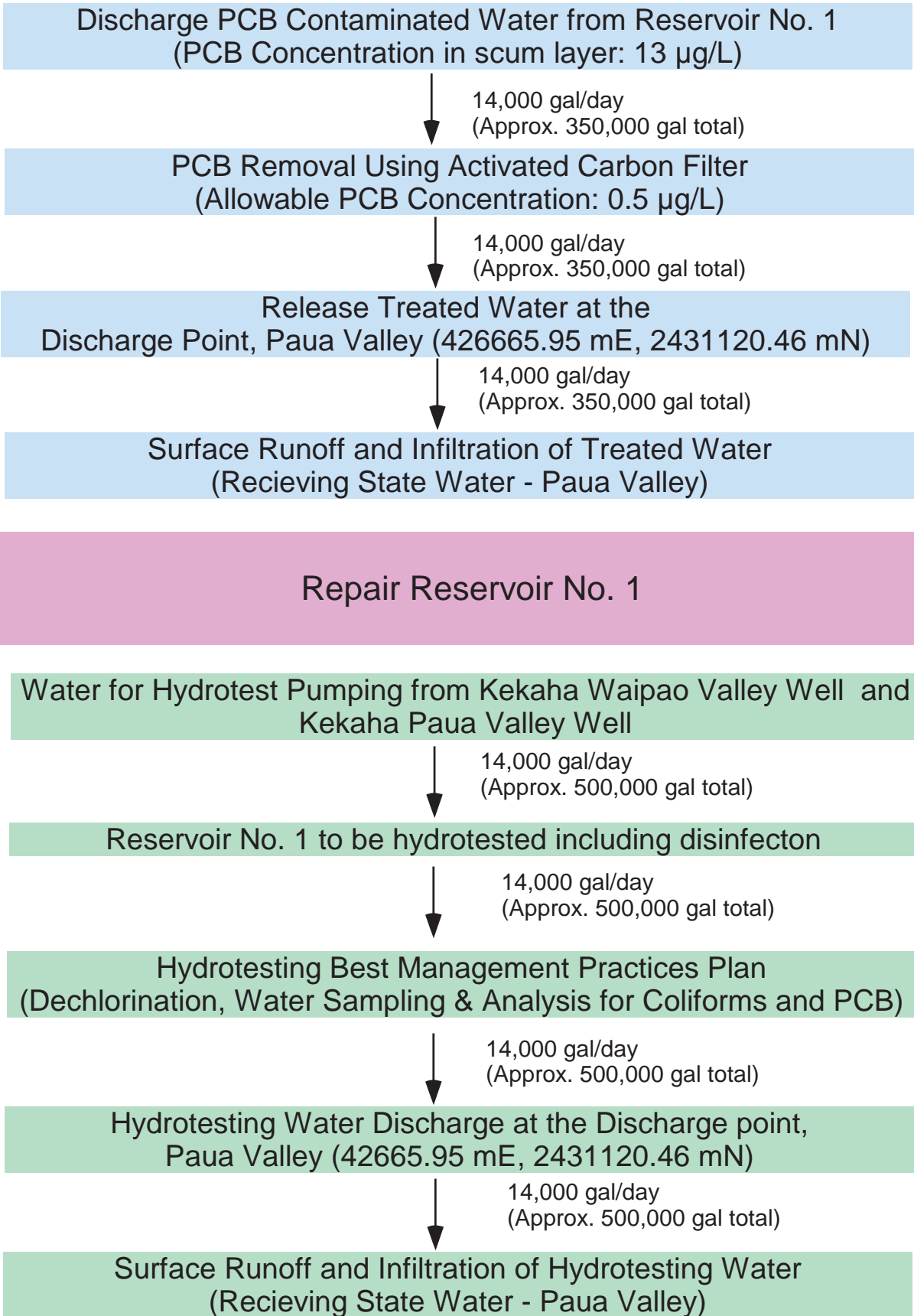
Figure 1. Site Location Map  
 NOI Form F  
 Kekaha 0.5 MG Reservoir No. 1  
 Kekaha, Island of Kauai











**Figure 5. Flow Chart (F.2)  
Kekaha 0.5 MG Reservoir No. 1**

***Attachment B – Water Quality Report – Kauai Department of Water***

# **Water Quality Report**

Covering the period of  
January 1, 2017 to December 31, 2017



Kaua'i Department of Water  
Kekaha-Waimea Water System  
2018

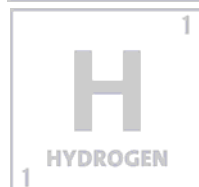
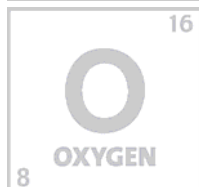


This report by the Kaua'i Department of Water describes the quality of your drinking water, and where it comes from. The Safe Drinking Water Act, a federal law, requires water utilities to provide water quality information to its customers every year.

Providing safe drinking water is a complex business, but you and your neighbors have a right to know the results of our water quality monitoring. Safe drinking water is essential to our community. Your water is tested regularly through our certified laboratories and the State Department of Health.

In summary, our drinking water meets, or is better than, state and federal standards. We spend in excess of \$400,000 in chemical and microbial testing each year to assure the safety of your water.

A Source Water Assessment, intended to enable "well-founded, fair and reasonable decisions for the protection and preservation of Hawai'i's drinking water" has been completed by the State Department of Health and the University of Hawai'i. For Further information on this assessment, please contact the Department of Water at (808) 245-5455.



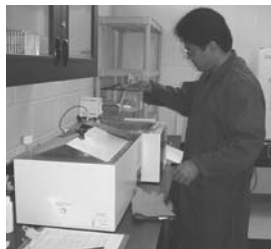
We welcome your interest in the Department of Water's water system. Please refer to the directory in this publication for the Department's phone numbers. Also, the Water Board normally meets on the fourth Friday of each month, and their meetings are open to the public. Please call (808) 245-5406 for the time, date and location.

Beth Tokioka  
***Chairperson, Board of Water Supply***

Bryan Wienand, P.E.  
***Manager and Chief Engineer***

## Why am I getting this brochure?

The Safe Drinking Water Act has been amended to require water systems to provide its customers with an annual report of the quality of their drinking water. This brochure is a snapshot of the quality of the water we provided last year. Included are details about where your water comes from, what it contains and how it compares to Environmental Protection Agency (EPA) and state standards.



We are committed to providing you with information because informed customers are our best allies.

## Is my drinking water safe?

**Yes.** The Department of Water regularly conducts microbiological analysis and has contracted for extensive chemical testing in order to comply with Environmental Protection Agency (EPA) and Hawai'i State standards. The standards are very strict in order to ensure safe drinking water.

## Where does my water come from?

Your water comes from ground water (**underground**) sources. Rain that falls in the mountain filters through the ground into formations called aquifers. Wells are drilled into these formations and the water is pumped out. These formations can also be found in the mountains (**still considered ground water**). Tunnels are constructed to tap these sources. The quality of groundwater is very good and requires no treatment except for disinfection (**as opposed to surface water sources that require filtration and stronger disinfection**).

The water supply for the Kekaha-Waimea Water System water system comes from the following sources:

***Kekaha, Waipa'o Valley Well***

***Waimea Well A***

***Kekaha, Pau'a Valley Well***

***Waimea Well B***

***Kekaha Shaft 12***

***Kapilimao Well***

All of the water is chlorinated and pumped into the distribution system or stored in the following tanks:

***Kapilimao  
500,000 gallon tank***

***Waimea  
100,000 gallon tank***

***Kekaha  
500,000 gallon tanks @ 2 each***

***Waimea  
200,000 gallon tank***

***Waimea - 500,000 gallon tank***

## How do contaminants get into our drinking water?

The sources of drinking water (*both tap water and bottled water*) include rivers, lakes, streams, ponds, reservoirs, springs and wells.

As water travels over the surface of the land or through the ground, it dissolves naturally occurring minerals and, in some cases, radioactive material, and can pick up substances resulting from the presence of animals or from human activity.

Therefore, drinking water, including bottled water may reasonably be expected to contain at least small amounts of some contaminants. The presence of contaminants does not necessarily indicate that the water poses a health risk.

Contaminants that may be present in source water before we treat it include:

Microbial contaminants: Viruses and bacteria from sewage treatment plants, septic systems, agricultural livestock operations and wildlife.

Inorganic contaminants: Salts and metals which can be naturally occurring or from other sources, such as urban storm water runoff, industrial or domestic wastewater discharges, oil and gas production, mining or farming.

Pesticides and herbicides: Variety of sources such as agriculture, urban storm water runoff and residential uses.

Radioactive contaminants: Naturally occurring.

Organic chemical contaminants: Synthetic and volatile organic chemicals, by-products of industrial processes and petroleum production, also from gas stations, urban storm water runoff, and septic systems.

To ensure safe tap water, EPA sets limits on these substances in water provided by public water systems.



## Should I take special precautions?

Some people may be more vulnerable to contaminants in drinking water than the general population. Immuno-compromised persons such as persons with cancer undergoing chemotherapy, persons who have undergone organ transplants, people with HIV/AIDS or other immune system disorders, some elderly and infants can be particularly at risk from infections. These people should seek advice about drinking water from their healthcare providers.

EPA/CDC (Centers for Disease Control) guidelines on appropriate means to lessen the risk of infection by *Cryptosporidium* and other microbial contaminants are available from EPA's Safe Drinking Water Hotline (1-800-426-4791).

More information about contaminants can also be obtained by calling the EPA's Hotline.

## Other Frequently Asked Questions:

### ***What is the pH of my water?***

The pH of your water in the Kekaha-Waimea area can range from 7.4 to 7.8.

### ***What is the hardness of my water?***

The hardness of your water can range from 60 to 190 ppm.

### ***Why do I notice off-odors or taste in my water?***

Sometimes if water in your house is not used, the microbes in the pipes can grow and cause odors and funny taste. Flushing the water can resolve this problem. Water should be flushed in the morning or when not used for an extended period of time.

### ***What causes my water to look milky when it comes out of the faucet?***

Air trapped in the water lines causes this problem. Let the water sit in a glass. The water becomes clear from the bottom up if air is the cause. The water is safe to drink.

### ***Why is chlorine added to my water?***

Chlorine is added to control microbe levels in the water distribution system to keep the water safe. The chlorine level ranges between 0.1 to 0.5 ppm. The small amounts of chlorine in the water do not pose a health hazard. If you want to remove chlorine, either let it sit for a while or filter it through an activated carbon filter.



## Water Quality Data

We are required to test your tap water for:

- Different types of chemical contaminants: Regulated contaminants, each with a maximum contaminant level (MCL) and a maximum contaminant level goal (MCLG); and unregulated contaminants, which don't have maximum contaminant levels.
- Coliform bacteria.
- Heavy metals (lead and copper).

Remember that just because these contaminants may be present in your water, it doesn't mean your water has a health risk.

This past year, we tested your water for a wide array of contaminants. Most of them were not found in your water, and only those that we found are reported in the test results section that follows.





**Microbiological Contaminants**

Total Coliform Bacteria  
Fecal Coliform Bacteria

**Radioactive Contaminants**

Alpha emitters  
Beta/photon emitters  
Radium

**Inorganic Contaminants**

Antimony  
Arsenic  
Asbestos  
Barium  
Beryllium  
Cadmium  
Chromium  
Copper  
Cyanide  
Fluoride  
Lead  
Mercury  
Nitrate  
Nitrite  
Selenium  
Thallium

**Organic Contaminants**

2,4-D  
2,4,5-TP[Silvex]  
Acrylamide  
Alachlor  
Atrazine  
Benzo(a)pyrene  
Carbofuran  
Chlordane  
Dalapon  
Di(2-ethylhexyl) adipate  
Di(2-ethylhexyl) phthalate  
Dibromochloropropane  
Dinoseb  
Diquat  
Dioxin  
Endothall  
Endrin  
Epichlorohydrin  
Ethylene dibromide  
Glyphosate  
Heptachlor  
Heptachlor epoxide  
Hexachlorobenzene  
Hexachlorocyclopentadiene  
Lindane  
Methoxychlor  
Oxamyl [Vydate]  
PCBs [Polychlorinated biphenyls]  
Pentachlorophenol  
Picloram  
Simazine  
Toxaphene

**Volatile Organic Contaminants**

Benzene  
Carbon tetrachloride  
Chlorobenzene  
o-Dichlorobenzene  
p-Dichlorobenzene  
1,2-Dichloroethane  
1,1-Dichloroethylene  
Cis-1,2-Dichloroethylene  
trans-1,2-Dichloroethylene  
Dichloromethane  
1,2-Dichloropropane  
Ethylbenzene  
HAA (Haloacetic Acid)  
Styrene  
Tetrachloroethylene  
1,2,4-Trichlorobenzene  
1,1,1-Trichloroethane  
1,1,2-Trichloroethane  
Trichloroethylene  
1,2,3-Trichloropropane  
TTHMs [Total trihalomethanes]  
Toluene  
Vinyl Chloride  
Xylenes

**Unregulated Contaminants**

2,4,5-T  
2-4-DB  
Aldicarb  
Aldicarb sulfone  
Aldicarb sulfoxide  
Aldrin  
Butachlor  
Carbaryl  
Dicamba  
Dieldrin  
3-Hydroxycarbofuran  
Methiocarb  
Methomyl  
Metolachlor  
Metribuzin  
Molinate  
Nickel  
Paraquat  
Propachlor  
Propoxur  
Thiobencarb

**Results:**

The following tables list all the drinking water contaminants that were found in 2017. Unless otherwise noted, the data presented in the following tables are from testing done January 1 - December 31, 2017.

The State requires us to monitor for certain contaminants less than once per year because the concentrations of these contaminants are not expected to vary from year to year. Thus, some of the data, though representative of the water quality, is more than one year old.

This Consumer Confidence Report (CCR) reflects changes in drinking water regulatory requirements during 2016. All water systems were required to comply with the Total Coliform Rule from 1989 to March 31, 2016, and began compliance with a new rule, the Revised Total Coliform Rule on April 1, 2016. The new rule maintains the purpose to protect public health by ensuring the integrity of the drinking water distribution system and monitoring for the presence of microbial (i.e. total coliform and E. coli bacteria). The U.S. EPA anticipates greater public health protection under this new rule, as it required water systems that are vulnerable to microbial contamination to identify and fix problems. As a result, under the new rule there is no longer a monthly maximum contamination level violation for multiple total coliform detections. Instead, the new rule requires water systems that exceeds a specified frequency of total coliform occurrences to conduct an assessment to determine if any sanitary defects exist. If found, these must be corrected by the public water system.

## **Terms and abbreviations used below:**

**Maximum Contaminant Level Goal (MCLG):** is the level of contaminant in drinking water below which there is no known or expected risk to health. MCLGs allow for a margin of safety.

**Maximum Contaminant Level (MCL):** the highest level of a contaminant that is allowed in drinking water. MCLs are set as close to the MCLGs as feasible using the best available treatment technology.

**Action Level (AL):** the concentration of a contaminant which, when exceeded, triggers treatment or other requirements which a water system must follow.

n/a: not applicable.

nd: not detectable at testing limit.

ppm: parts per million or milligrams per liter  
(corresponds to one penny in \$10,000).

ppb: parts per billion or micrograms per liter  
(corresponds to one penny in \$10,000,000).

pCi/L: picocuries per liter  
(a measure of radiation).

mrem/year: millirems per year  
(a measure of radiation exposure).



### Microbiological Contaminants:

Substance	Highest Level Allowed (MCL)	EPA MCLG	Highest Monthly # of Positive Samples	Date	Violation	Source of Contaminant
None Detected						

### Inorganic Contaminants:

Substance	Highest Level Allowed (MCL)	EPA MCLG	Highest Level Detected	Detection Range	Date	Violation	Source of Contaminant
Chromium (ppb)	100	100	10	3-10	2016	No	Erosion of Natural Deposits
Nitrate (ppm)	10	10	3	2-3	2016	No	Runoff from fertilizer use; leaching from septic tanks, sewage; erosion of natural deposits

### Organic Contaminants:

Substance	Highest Level Allowed (MCL)	EPA MCLG	Highest Level Detected	Detection Range	Date	Violation	Source of Contaminant
TTHMs (Total trihalomethanes) (ppb)	80	NA	3	-	2017	No	By-Product of drinking water chlorination

### Lead and Copper Rule Compliance:

Substance	Action Level	EPA MCLG	90th Percentile Value	Detection Range	# of Sites Found Above AL	Date	Source of Contaminant
Lead (ppb)	15	0	<5	ND-8	0/20	2015	Corrosion of household plumbing systems
Copper (ppm)	1.3	1.3	0.06	ND-0.16	0/20	2015	Corrosion of household plumbing Systems

The Kekaha-Waimea system is in compliance with the Lead and Copper Rule Requirements and is on a reduced monitoring schedule. Samples for lead and copper will be taken and analyzed every three years from residential customers.

### Unregulated Contaminants:

Substance	Highest Level Allowed (MCL)	EPA MCLG	Highest Level Detected	Detection Range	Date	Violation	Source of Contaminant
None Detected							

### Radioactive Contaminants:

Substance	Highest Level Allowed (MCL)	EPA MCLG	Highest Level Detected	Detection Range	Date	Violation	Source of Contaminant
Beta Emitters (pCi/L)	-	0	4	ND-4	2016	No	Erosion of Natural Deposits
Alpha Emitters (pCi/L)	15	0	13	ND-13	2016	No	Erosion of Natural Deposits

If present, elevated levels of lead can cause serious health problems, especially for pregnant women and young children. Lead in drinking water is primarily from materials and components associated with service lines and home plumbing. The Department of Water is responsible for providing high quality drinking water, but cannot control the variety of materials used in plumbing components. When your water has been sitting for several hours, you can minimize the potential for lead exposure by flushing your tap for 30 seconds to 2 minutes before using water for drinking or cooking. If you are concerned about lead in your water, you may wish to have your water tested. Information on lead in drinking water, testing methods, and steps you can take to minimize exposure is available from the Safe Drinking Water Hotline or at <http://www.epa.gov/safewater/lead>.

## Where to call

<b>Who</b>	<b>About</b>	<b>Number</b>
Kaua'i Dept. of Water	General Inquiries Water Quality Report	(808) 245-5400
State Dept. of Health	Contaminants, health effects	(808) 586-4258
EPA Safe Drinking Water Hotline	Contaminants, health effects	1-800-426-4791

**Attachment C – Glossary of Chemicals (Section F.8)**

*This glossary is for general use and is not intended to be a complete or definitive reference. The parameters are categorized into Metals, Organonitrogen Compounds, Pesticides, Phenols, Phthalates, Polynuclear Aromatic Hydrocarbons, Volatile Organics, and Others and are listed alphabetically.*

*The information was obtained primarily from Environmental Protection Agency (EPA) Ambient Water Quality Criteria documents which are referenced in EPA's Quality Criteria for Water (EPA 440/5-86-001), updated May 1, 1987. Additional information was obtained from the EPA pamphlet "Suspended, Cancelled and Restricted Pesticides," January 1985; The Condensed Chemical Dictionary, 10th Ed. (Van Nostrand Reinhold Co., Inc., New York, 1981); and The Farm Chemicals Handbook (Meister Publishing Company, Willoughby, OH, 1988).*

*Information on organotins was obtained from the International Organotin Symposium held at Halifax, Nova Scotia in September 1987 and published in Volume 4 of the Oceans '87 Proceedings, by the Marine Technology Society, Washington D.C., and IEEE Ocean Engineering Society, Piscataway, NJ.*

a. *Metals*

*Antimony - A metal used as a hardening alloy for lead, particularly in lead-acid batteries. Also used as a semiconductor and in pyrotechnics.*

*Arsenic - A metal used as an alloy with lead and copper in shot, batteries, and cables. Arsenic trioxide is used as a pigment and as an insecticide, rodenticide, herbicide, sheep and cattle dip, hide preservative, and wood preservative. It was used as a pesticide in the production of cane panels in Hilo. Use in houses is restricted to concentrations below 1.5 percent. Carcinogen.*

*Beryllium - A metal for various high-technology uses including nuclear reactor moderator and structural material. Carcinogen.*

*Cadmium - A metal used in electroplating and coating, alloys, nickel-cadmium batteries, pigments, and in a variety of other industrial areas.*

*Chromium - A metal used in plating, alloys and in pigments. Hexavalent forms are most toxic and are used in cooling tower additives.*

*Copper - A metal used in wiring, plumbing, electroplating, alloys, insecticides, and in anti-fouling paints.*

*Lead - A metal used in batteries, gasoline additives, solder, and ammunition.*

*Mercury - A metal used in dentistry, electronics, instruments, lamps, metallurgy and formerly in anti-fouling paints.*

*Nickel - A metal used in alloys, electroplating, and batteries.*



*Selenium - A metalloid element used in electronics, rubber production, dandruff shampoo, and a trace element in animal feed.*

*Silver - A metal with various electronic, chemical, plating, photographic, and dental uses.*

*Thallium - A metal. Pesticide registration of thallium sulfate cancelled.*

*Tributyltin - Tributyltin is of environmental concern primarily because of its use in marine anti-fouling paints. This use has recently been restricted by Congress. Organotins have also been used in agriculture and residential areas to control fungi and insects including moths, houseflies, cockroaches, and mosquito larvae. The largest use is in stabilizing polyvinyl chloride polymers used in construction materials and food packaging.*

*Zinc - A metal used in alloys, electroplating, galvanizing, batteries, and cathodic protection.*

*b. Organonitrogen Compounds*

*Benzidine - Aromatic amine used in dye production. Carcinogen.*

*Dinitro-o-cresol - Pesticide, fungicide, insecticide and miticide. Also used as a blossom-thinning agent on fruit trees.*

*Dinitrotoluene - Commercial and military explosive.*

*Diphenylhydrazine - Used as a reagent for the sugars arabinose and lactose and for the production of phenylbutanone and benzidine.*

*Nitrobenzene - Used in the production of aniline dyes, rubber, medicinals, metal polish, shoe black, perfume, and as a combustion propellant and chemical reaction, and crystallizing solvent.*

*Nitrosamines - Only small quantities are synthesized for research and rubber and pesticide production. Primary environmental exposure is probably due to the nitrosation of amine*

*and amide precursors in reactions in air, soil, water, food, and animal systems. Carcinogen.*

*c. Pesticides*

*Aldrin - Insecticide used in ground injection for termite control and non-food plant dip. Registration for other uses cancelled. Metabolizes to dieldrin. Carcinogen.*

*Chlordane - Insecticide used for termite control and non-food plant dip. Registration for other uses cancelled. Carcinogen.*

*Chlorpyrifos - Organophosphorus insecticide (a.k.a. Dursban, Lorsban). Used locally for termite control.*

*DDT - Persistent lipid-soluble chlorinated pesticide. Formerly most widely used. All pesticide uses cancelled except by government agencies and physicians. Metabolizes to DDE and TDE. Carcinogen.*

*Demeton - Systemic insecticide and acaricide applied as a foliage spray and soil drench.*

*Dieldrin - Persistent insecticide used in ground injection for termite control and as non-food plant dip. Registration for other uses cancelled. Carcinogen.*

*Endosulfan - Insecticide and acaricide (a.k.a. Thiodan). Used on pineapples in Hawaii.*

*Endrin - Pesticide, rodenticide, and avicide. Used on sugarcane to control the sugarcane beetle. Registration cancelled for control of the sugarcane borer. Teratogen.*

*Guthion - Organophosphorus pesticide used for many pests on various fruits, melons, nuts, vegetables, field crops, ornamental, and shade trees.*

*Heptachlor - Insecticide registered for termite control and non-food plant dip. Registration for other uses cancelled. Carcinogen.*

*Lindane - Broad spectrum insecticide used in livestock sprays, forestry, christmas trees, structural treatments, hardwood logs and lumber, dog sprays, dusts and dips, flea collars, moth sprays, seed treatments, shelf paper, and household sprays. Carcinogen.*

*Malathion - Organophosphorus insecticide used for many insects including: aphids, spider mites, scale insects, house flies, mosquitos, and for insects attacking fruits, vegetables, ornamental and stored products. Used in public health programs to control mosquitos.*

*Methoxychlor - Organochlorine pesticide.*

*Mirex - Organophosphorus insecticide. Registration cancelled 12/01/77. Mirex was used to control fire ants on pineapples in Hawaii.*

*Parathion - Organophosphorus pesticide used on fruit, nut, vegetable, and field crops. TDE - Metabolite of DDT. Carcinogen.*

*Toxaphene - 175 compounds of chlorinated camphene. Formerly the most heavily used pesticide. Registration cancelled in 1982 with exceptions for cattle, pineapples, and bananas. No U.S. production. Persistent in the environment. Carcinogen.*

#### *d. Phenols*

*Chlorinated Phenols - (Includes chlorinated cresols). Synthesis of dyes, pigments, resins, pesticides, herbicides and used directly as flea repellents, fungicides, wood preservatives, mold inhibitors, antiseptics, disinfectants, and anti-gumming agents in gasoline. Chlorinated phenol pesticide products include 2,4-D, 2,4-DCP, 2,4,5-T, 2,3,4,6-TCP, and PCP. Some forms carcinogenic.*

*2-Chlorophenol - Intermediate in chemical production of fungicides, slimicides, bactericides, antiseptics, disinfectants, and wood and glue preservatives. Can be produced in the chlorination of drinking water and sewage. May be biodegraded.*

*2,4-Dichlorophenol - Used in the production of herbicides (2,4-D) and in mothproofing, antiseptics, and seed disinfectants. Metabolic and photodegradation product of the above.*

*Nitrophenols - 2,4,6 trinitrophenol (picric acid) has been used as an explosive, dye intermediate, reagent, germicide, fungicide, staining agent and tissue fixative, and in photochemicals, pharmaceuticals, and metal etching. Mono and dinitrophenols*

would occur in the environment primarily from discharges from manufacturing plants or possibly from the degradation of pesticides. They are used in the production of dyes, photochemicals, pesticides, wood preservatives, explosives, and leather treatments. See also 2,4 dinitro-o-cresol.

*Pentachlorophenol - Very common pesticide, fungicide, and bactericide (a.k.a. PCP).*

*Phenol - Used in production of epoxy and phenolic resins, pharmaceuticals, germicides, fungicides, slimicides, herbicides, dyes and acids, and as a disinfectant and antiseptic.*

e. *Phthalates*

*Phthalate Esters - Plasticizers used especially in Polyvinyl chloride (PVC) production. Easily extractable and up to 60 percent of the total weight of plastic. Also used in the production of pesticide carriers, cosmetics, fragrances, munitions, industrial oils, and insect repellents.*

f. *Polynuclear Aromatic Hydrocarbons*

*Acenaphthene - Coal tar product used in the manufacturing of dyes and plastics and as an insecticide and fungicide. Also detected in cigarette smoke and gasoline exhaust.*

*Fluoranthene - A polynuclear aromatic hydrocarbon. Primarily a pyrolysis product formed in frying, smoking, incineration, etc. Natural as well as man-made sources. Carcinogen.*

*Naphthalene - Primary parameter of coal tar. Used in dye production, formulation of solvents, and chemical synthesis. Also used in lubricants and motor fuels, and as a moth repellent, insecticide, anthelmintic, vermicide, and intestinal antiseptic.*

*Polynuclear Aromatic Hydrocarbons - Diverse class of compounds formed by incomplete combustion of organics with insufficient oxygen. Examples include benzo[a]pyrene and benz[a]anthracene. Carcinogen.*

g. *Volatile Organics*

*Acrolein - Biocide for weed, algae, mollusk and slime control, and to protect liquid fuels from microorganisms. Also used in leather tanning, tissue fixation, paper, textiles, crease-proofing cotton, and as a chemical intermediate, plasticizer, copolymer in photography, builder in laundry and dishwashing detergents, and coating for aluminum and steel.*

*Acrylonitrile - Copolymer used in the production of fibers and plastics (e.g., ABS Acrylonitrile-Butadiene-Styrene plastic), and latexes and chemicals. Banned as a resin for soft drink containers and as a fumigant. Similar toxic effects as cyanide. Carcinogen.*

*Benzene - Coal tar and petroleum product used in pharmaceutical and chemical synthesis, including the production of styrene, detergents, pesticides, thinners, and inks. Also used as a cleaner and degreaser, solvent, and gasoline anti-knock additive. Carcinogen.*

*BHC - Benzene hexachloride. See hexachlorocyclohexane and lindane. Carcinogen.*

*Carbon Tetrachloride - Solvent and grain fumigant also used in fire extinguishers. Carcinogen.*

- Chlorinated Benzenes - Solvents for fats, oils and greases, also used as fumigants, degreasers, lubricants, dielectrics, dye carriers, wood preservatives; in chemical, pesticide, and herbicide production; heat transfer; military pyrotechnics; and termite control. Carcinogen.*
- Chlorinated Ethanes - Used in the production of tetraethyl lead and vinyl chloride and as solvents and chemical intermediates. Some forms carcinogenic.*
- Chloroalkyl ethers - Used in organic synthesis, textiles, ion exchange resins, pesticides, and reaction solvents.*
- Chloroform - Chemical solvent. Formed in the chlorination of sewage and water supplies. Carcinogen.*
- Dichlorobenzenes - Used in air deodorants, insecticides, chemical production, dyes, herbicides, and degreasers.*
- Dichlorobenzidine - Used in the production of dyes and pigments and a curing agent for polyurethanes. Carcinogen.*
- Dichloroethylenes - Intermediate in chemical production, and polyvinylidene chloride copolymers in food packaging materials (e.g., plastic wrap) and tank coatings. Degradation products of larger chlorinated hydrocarbons. Carcinogen.*
- Dichloropropane - Soil fumigant for nematodes, oil and fat solvent, and degreaser. Dichloropropene - Soil fumigant for nematodes, used in Hawaii on pineapples. Also oil and fat solvent and degreaser.*
- Ethylbenzene - Up to 20 percent of gasoline. Widespread commercial use including production of styrene, diluents in paints, and used as insecticides.*
- Hexachlorobutadiene - Organic solvent used in chlorine production recovery, in rubber and lubricant production, and as a gyroscope fluid. Carcinogen.*
- Hexachlorocyclohexane - Broad spectrum insecticide (a.k.a. BHC). Only the gamma isomer, lindane, is currently registered and produced. Carcinogen.*
- Hexachlorocyclopentadiene - Base of several chlorinated pesticides including: aldrin, dieldrin, chlordane, heptachlor, endrin, isodrin, kepone, mirex, endosulfan, and pentac. Also used in the production of flame retardants.*
- Isophorone - Solvent for fats, oils, gums, natural and synthetic resins, cellulose derivatives, lacquers, pesticides and herbicides. Used in chemical and plant growth retardant production.*
- Tetrachloroethylene - Solvent in textile and dry cleaning, metal cleaning, and chemical production (a.k.a. perchloroethylene or PCE). Carcinogen.*
- Toluene - Aviation fuel and high-octane blending stock, chemical intermediate, thinner, solvent for paints, gums, resins, oils, rubber, and vinyl, and used in plastic cement, chemicals, explosives, and detergents.*
- Trichlorinated ethanes - Metal degreaser, chemical intermediate, adhesive and resin solvent, pesticide, dry cleaning solvent, formerly used as a fumigant 1,1,2 isomer carcinogenic.*

*Trichloroethylene - Degreasing solvent in metal industries. Formerly dry cleaning solvent and extractive solvent in foods (a.k.a. TCE). Carcinogen.*

*Vinyl chloride - Polymerized in the production of PVC, the most widely used material in the manufacture of plastics. All pesticide uses cancelled (whether an active or inert ingredient) for uses in the home, food handling establishments, hospitals, and enclosed areas. Degradation product of larger chlorinated hydrocarbons. Carcinogen.*

*h. Others*

*Chlorine - Chlorine is commonly used to disinfect wastewater and water supplies and to control fouling organisms in cooling water systems.*

*Cyanide - Used and formed in many industrial processes including steel, petroleum, plastics, synthetic fibers, metal plating, mining, and chemical industries.*

*Dioxin - Trace contaminant of chlorinated phenols, chlorinated phenoxy acids (especially the herbicide 2,4,5-T and Silvex), and hexachlorophene. Carcinogen.*

*Polychlorinated biphenyls (PCBs) - Used as a transformer and capacitor fluid. Also used as a heat transfer, hydraulic, compressor, and vacuum pump fluid, plasticizer, and in lubricants and wax extenders. No longer manufactured in the United States. All pesticide uses eliminated. Carcinogen.*

**Attachment D – Hydrotesting BMPs Plan (Section F.9)***HYDROTESTING BMPS PLAN*

The selected Contractor will revise or modify this plan and submit the final plan at least 30 days before the start of discharging. The Contractor will be required to install silt fences for erosion control during construction as presented in Appendix E, Reservoir Repair Plan, Drawing R-1, Reservoir Repair Site Plan.

**1.0 Discharge PCB-Containing Water from Reservoir No. 1****1.1 BACKGROUND:**

Currently the reservoir contains approximately 0.35 MG of PCB contaminated water. The detected PCB concentration was 0.013 mg/L (13 µg/L) on the water surface (scum layer) in excess of the 0.0005 mg/L (0.5 µg/L) allowable limit for potable water. The water from the effluent line drawn from the bottom of the reservoir does not have any detected PCB concentration.

**1.2 DISCHARGE LOCATION AND SCHEDULE:**

The water in the reservoir will be discharged into Paua Valley at a rate to allow the discharged water to infiltrate into the ground surface before reaching approximately 200 feet downstream of the reservoir discharge pipe. The tentative discharge rate is about 14,000 gallons/day based on the PCB water treatment rate with activated carbon filtration and infiltration rate into the ground surface.

**1.3 DISCHARGE PROCEDURE AND SAMPLING PLAN:**

- 1) Test water at effluent line sampling tap which draws water from the bottom region of the reservoir water to confirm the PCB-concentration is within the allowable limit (0.5 µg/L) to allow water to be discharged without any filtration. EPA Method 505 will be used for water testing.
- 2) If the PCB concentration in water from Step 1 is below the allowable limit (0.5 µg/L), SLOWLY discharge water from the reservoir cleanout drain line to minimize the mixing of the water with the PCB-containing “scum” layer on the water surface. Drain continuously at a slow rate until the water level reaches a depth of approximately 2 feet.
- 3) Connect piping at end of drainage discharge pipe from reservoir by removing flap gate valve and connect two drums containing virgin activated carbon 8 x 12 mesh design to absorb PCB. The discharge rate for two units connected in parallel is 10 gallons per minute. This absorber unit drum is a manufactured assembly. Release as much water as will drain by gravity. The remaining residue will be left for the project contractor to clean up as part of the interior coating removal work.

Activated Carbon Filter Drum: There will be two activated carbon filter drums. Approximately 150-200 pounds of virgin activated carbon will be contained in each 55-gallon drum. Each filter will be capable of handling a flow of at least 10 gpm, with a

maximum operating pressure of 6 psi. This manufactured assembly can be purchased from the following manufacturers:

- a. "Econosorb-LS", by TIGG Corporation, 1 Willow Avenue, Oakdale, PA,  
Phone: (724) 703-3020, [www.tigg.com](http://www.tigg.com).
- b. "Water Purification Canister L-1", by Carbtrol Corporation, 955  
Connecticut Ave., Suite 5202, Bridgeport, CT 06607, Phone: (800) 242-  
1150, [www.carbtrol.com](http://www.carbtrol.com).

A layer of absorbent pad will be placed on the top surface of activated carbon. This absorbent pad will remove PCB-containing "scum" layer of the upper region of the reservoir.

- 4) Take a follow-up effluent water sample, discharged from the activated carbon filter units to confirm the PCB-concentration is below the allowable limit, 0.5 µg/L, and analyze using EPA Method 505. If the PCB result is greater than 0.5 µg/L, the Contractor shall stop discharging water and replace granular activated carbon or add an additional treatment such as bag filters with 0.5 µm after carbon filtration. Repeat this step until the PCB concentration is below the allowable limit.
- 5) Upon water discharge is completed, the used absorbent pad and activated carbon will be sampled and tested for PCB and Toxicity Characteristic Leaching Procedure (TCLP)-RCRA 8 metals (Method 1311) to determine if the waste is hazardous or non-hazardous. If PCB concentrations are less than 50 ppm and TCLP-metal results are below the regulatory limits, the absorbent pad and activated carbon will be determined as non-hazardous waste and disposed of at the municipal landfill with no special requirements.
- 6) If the PCB concentrations are greater than 50 ppm or TCLP-metal results are greater than the TCLP limits, those materials will be determined as hazardous waste and will be disposed of at a permitted hazardous waste landfill in the Mainland.
- 7) EPA may issue an approval document per TSCA requirements for the disposal of the used oil-soaked absorbent pad and activated carbon on the requested test results obtained along the process.

#### 1.4 SAMPLE COLLECTION AND LABORATORY ANALYSIS:

Collected samples shall be stored between 0 - 4 °Celsius until the samples are delivered to the laboratory. The samples shall be stored at the required temperature immediately after collection to preserve the condition at the time of collection. The sampler shall coordinate further with an analytical laboratory to confirm the testing method, sample amount, and sample preservation requirements.

## **2.0 Repair Reservoir**

Following the PCB contaminated water discharge and PCB waste disposal activities, the rehabilitation of the existing reservoir will continue with the removal of the existing interior coating and installation of a new interior coating system of the floor, pipe exterior, wall, and column surfaces.

The interior coating system will be NSF 61 certified and be installed following quality control procedures with applicable ASTM, NACE, and SSPC standards and the protective coating manufacturer's recommendation. The new coating system will cover all existing surfaces that was once in contact with PCB.

## **3.0 Hydrotesting, Disinfection, and PCB monitoring**

Prior to placing the reservoir back in service, the Department of Water and the selected Contractor will conduct hydrotesting and disinfection process in accordance with the Attachment F.

In order to confirm that the water in the reservoir is acceptable for potable use, the Contractor shall collect at least two (2) water samples from the reservoir to test coliforms and PCBs in portable drinking water.

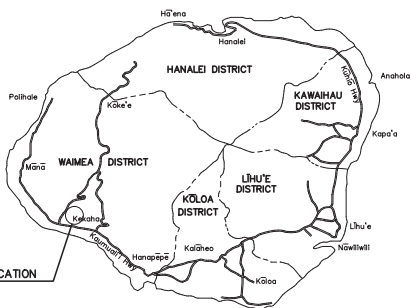
Chlorine will be present in nominal amounts as it will be used to disinfect the tank. The valve will remain closed as the reservoir is being cleaned, and the disinfected liquid will be dechlorinated to acceptable levels as specified under section 303.10 of the Water System Standards, dated 2002, before being discharged into Paua Valley (Receiving Water). Treated hydrotesting effluent will be sampled prior to discharge into the drain line.

After dechlorination, the hydrotesting water will be discharged to the ground surface along Paua Valley as presented in Figure 4. The water will be allowed to flow and seep into the ground.

Following confirmation that coliforms and PCBs levels are acceptable for the portable drinking water, the reservoir will be placed back in service. The Department of Water will sample and test the water using EPA Method 505 for PCB on a quarterly basis for three (3) quarters. If PCB is still at non-detectable levels for that period of time, sampling will continue on an annual basis. Sampling and testing operations may cease upon confirmation that PCB concentrations are at non-detectable levels for the next three (3) consecutive years.

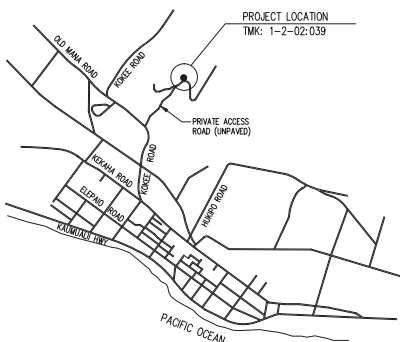


***Attachment E – Reservoir Repair Plan***



**ISLAND OF KAUA'I**

NOT TO SCALE



**VICINITY MAP**

NOT TO SCALE

DEPARTMENT OF WATER  
COUNTY OF KAUA'I

JOB NO. 17-10, WP2020 PROJECT NO. KW-07  
**REHABILITATE PAUA VALLEY  
TANK NO. 1, 0.5 MG CONCRETE  
KEKAHA WATER SYSTEM**

Kekaha, Kaua'i, Hawai'i

Tax Map Key: (4) 1-2-02: 039

PREPARED BY:  
**KAI HAWAII, INC.**  
50 SOUTH BERETANIA STREET #C-119C  
HONOLULU, OAHU, HAWAII 96813

**INDEX TO DRAWINGS**

<u>SHEET NUMBER</u>	<u>DESCRIPTION</u>
T-1	TITLE SHEET
T-2	WATER CONSTRUCTION, STRUCTURAL NOTES, ABBREVIATIONS
T-3	BMP NOTES, RESERVOIR WATER DISCHARGE NOTES
R-1	RESERVOIR REPAIR SITE PLAN
R-2	RESERVOIR CROSS SECTION AND DETAILS
R-3	RESERVOIR REPAIR DETAILS
R-4	LEVEL INDICATOR DETAILS
R-5	RESERVOIR WATER DISCHARGE SCHEMATIC PLAN AND DETAILS

**APPROVED:**

\_\_\_\_\_  
DIRECTOR, PLANNING DEPARTMENT  
COUNTY OF KAUA'I

DATE

\_\_\_\_\_  
COUNTY ENGINEER, DEPT. OF PUBLIC WORKS  
COUNTY OF KAUA'I

DATE

\_\_\_\_\_  
CHIEF, ENVIRONMENTAL MANAGEMENT DIVISON, DEPARTMENT OF HEALTH  
STATE OF HAWA'I

DATE

\_\_\_\_\_  
MANAGER & CHIEF ENGINEER, DEPARTMENT OF WATER  
COUNTY OF KAUA'I

DATE

**WATER CONSTRUCTION NOTES (REVISED 09-SEPT-2017):**

- A. UNLESS OTHERWISE SPECIFIED, ALL MATERIALS AND CONSTRUCTION OF WATER FACILITIES AND APPURTENANCES SHALL BE IN ACCORDANCE WITH THE "WATER SYSTEM STANDARDS, 2002" AS ADOPTED BY THE DEPARTMENT OF WATER, COUNTY OF KAUAI, INCLUDING ALL SUBSEQUENT AMENDMENTS AND ADDITIONS.
  - B. ALL REQUIRED PROJECT SUBMITTALS (MATERIALS, SHOP DRAWINGS, CHLORINATION PLAN, ETC.) SHALL BE APPROVED BY THE DEPARTMENT CONSTRUCTION MANAGEMENT DIVISION BEFORE A PRE-CONSTRUCTION CONFERENCE CAN BE SCHEDULED. ONCE ALL PROJECT SUBMITTALS HAVE BEEN APPROVED BY DOW CONSTRUCTION ENGINEER, THE DOW CONSTRUCTION ENGINEER WILL NOTIFY THE CONTRACTOR THAT A PRECONSTRUCTION CONFERENCE CAN BE ARRANGED. THE CONTRACTOR SHALL ARRANGE A PRE-CONSTRUCTION CONFERENCE AT LEAST TEN (10) CALENDAR DAYS BEFORE CONSTRUCTION AND SHALL NOTIFY THE DEPARTMENT OF WATER AT LEAST THREE (3) WORKING DAYS PRIOR TO START OF CONSTRUCTION.
  - C. THE CONTRACTOR SHALL SUBMIT THE NAMES AND TELEPHONE NUMBERS OF ITS AUTHORIZED JOB SUPERINTENDENT AND AT LEAST THREE (3) ADDITIONAL PERSONS TO CONTACT IN CASE OF AN EMERGENCY DURING NON-WORKING HOURS.
  - D. THE CONTRACTOR SHALL NOTIFY THE DEPARTMENT OF WATER AT LEAST 24 HOURS PRIOR TO ANY TRENCHING, PIPE LAYING, BACKFILLING, TESTING OR DISINFECTION ACTIVITIES TO ENSURE THAT INSPECTION SERVICES WILL BE AVAILABLE.
  - E. ALL MATERIALS (PIPE, LUBRICANTS, PAINTS, SEALANTS, FORM OIL, CONCRETE ADMIXTURES, ETC.) IN DIRECT CONTACT WITH THE POTABLE WATER SHALL HAVE NATIONAL SANITATION FOUNDATION (NSF) CERTIFICATIONS. THE CONTRACTOR SHALL SUBMIT THESE CERTIFICATIONS TO THE DEPARTMENT OF WATER FOR REVIEW AND APPROVAL PRIOR TO ITS APPLICATION.
  - F. THE LOCATION OF EXISTING WATER MAINS AND APPURTENANCES SHOWN ON THE PLANS ARE APPROXIMATE ONLY. THE CONTRACTOR SHALL VERIFY THE EXACT LOCATIONS IN THE FIELD. EXCAVATION AROUND ANY EXISTING WATER MAIN SHALL BE DONE BY HAND.
  - G. THE CONTRACTOR SHALL PROVIDE UNOBSTRUCTED ACCESS TO EXISTING HYDRANTS, VALVES AND WATER METERS AT ALL TIMES.
  - H. THE CONTRACTOR SHALL SECURE ALL EXCAVATIONS IN ACCORDANCE WITH OSHA REGULATIONS.
  - I. THERE SHALL BE NO PHYSICAL CONNECTION BETWEEN A PUBLIC OR PRIVATE POTABLE WATER SYSTEM AND A NON-POTABLE WATER SYSTEM, SEWER, OR APPURTENANCE THERETO WHICH COULD PERMIT THE PASSAGE OF ANY SEWAGE OR POLLUTED WATER INTO THE POTABLE WATER SUPPLY.
  - J. TRENCH EXCAVATION, BACKFILLING IN LIFTS, AND REPAVING SHALL CONFORM TO THE HAWAII STANDARD SPECIFICATIONS FOR ROAD AND BRIDGE CONSTRUCTION, 2005 AS AMENDED.
  - K. WARNING TAPE SHALL BE IN ACCORDANCE WITH DIVISION 200, SECTION 212.08 OF THE "WATER SYSTEM STANDARDS." THE WARNING TAPE SHALL BE FOUR MIL THICK, NON-METALLIC, ACID AND ALKALI RESISTANT POLYETHYLENE AND 6-INCHES WIDE WITH MINIMUM STRENGTH OF 1750 PSI LENGTHWISE AND 1500 PSI CROSSWISE. TAPE COLOR SHALL BE "SAFETY PRECAUTION BLUE" AND SHALL BEAR A CONTINUOUS PRINTED INSCRIPTION "CAUTION WATER LINE BURIED BELOW." INSCRIPTION SHALL BE 2-INCHES HIGH, BLACK TEXT.
  - L. ALL HYDRANTS SHALL RECEIVE A MINIMUM SPS3 SURFACE PREPARATION AND COATED IN ACCORDANCE WITH DIVISION 200, SECTION 206.01 OF THE "WATER SYSTEM STANDARDS."
  - M. UNLESS OTHERWISE DIRECTED, PRIOR TO THE CONNECTION OF ANY PIPELINES AND/OR LATERALS TO THE EXISTING MAIN, THE PIPELINES/LATERALS INSTALLED SHALL BE CLEANED, PRESSURE TESTED, CHLORINATED, FLUSHED, AND SAMPLED IN ACCORDANCE WITH DIVISION 300, SECTIONS 302.27 TO 302.29 OF THE "WATER SYSTEM STANDARDS."
- WATER SAMPLES SHALL BE TESTED FOR TOTAL COLIFORMS BY A LABORATORY CERTIFIED BY THE STATE OF HAWAII TO PERFORM COLIFORM ANALYSIS. PRESENCE OF COLIFORM BACTERIA IS UNACCEPTABLE.
- IN ADDITION TO THE TEST FOR COLIFORMS, A SEPARATE TEST FOR HETEROTROPHIC PLATE COUNT (HPC) SHALL BE CONDUCTED. THE HPC COUNT SHALL BE LESS THAN 300 CFU/ML.
- PRIOR TO CHLORINATION, A WATER CHLORINATION AND SANITATION CONTRACTOR WITH A C-370 LICENSE SHALL SUBMIT A CHLORINATION PLAN WITH WATER SOURCE, INJECTION POINTS, SAMPLING POINTS AND PROCEDURE CLEARLY DEFINED FOR APPROVAL BY THE DOW.
- THE TESTED PIPELINES AND/OR LATERALS MUST BE CONNECTED TO THE EXISTING DOW SYSTEM WITHIN 14 CALENDAR DAYS OF PULLING THE FIRST DISINFECTION SAMPLE TESTED BY A CERTIFIED LABORATORY. THE DEPARTMENT OF WATER WILL REQUIRE THE CONTRACTOR TO REDO THE CLEANING, PRESSURE TESTING, AND/OR DISINFECTION OF THE PIPELINES AND/OR LATERALS AT THE CONTRACTOR'S EXPENSE IF THE CONNECTION IS NOT COMPLETED WITHIN THESE 14 CALENDAR DAYS.
- N. POLYURETHANE FOAM "PIPS" SHALL BE PUSHED THROUGH THE LENGTH OF THE INSTALLED PIPELINE USING PRESSURIZED WATER.
  - O. ALL CONNECTIONS SHALL BE SCHEDULED IN COORDINATION WITH THE DEPARTMENT OF WATER.
1. AN ADVANCE DEPOSIT IS REQUIRED FOR OPERATING VALVES, FLUSHING LINES AND NOTIFYING CONSUMERS AFFECTED BY A WATER SHUTDOWN DURING CONNECTIONS. THE CONTRACTOR WILL BE CHARGED THE ACTUAL COST.
  2. THE CONTRACTOR SHALL PLACE THE DEPOSIT PRIOR TO SCHEDULING THE CONNECTION DATE.
  3. CONNECTIONS SHALL BE SCHEDULED ON TUESDAYS THROUGH THURSDAYS. NO CONNECTIONS SHALL BE SCHEDULED ON MONDAYS, FRIDAYS, WEEKENDS, AND HOLIDAYS, OR FROM DECEMBER 18 - JANUARY 8 OF EACH YEAR.
  4. ALL MATERIALS SHALL BE ON HAND AND APPROVED BY THE ENGINEER PRIOR TO SCHEDULING THE CONNECTION DATE.
  5. PUMPS USED TO DE-WATER THE CONNECTION AREA SHALL BE OPERATED IN THE PRESENCE OF THE ENGINEER PRIOR TO SCHEDULING THE CONNECTION DATE.
  6. ALL CONNECTIONS SHALL BE PERFORMED IN THE PRESENCE OF THE ENGINEER.

- P. IN ORDER TO PREVENT DAMAGE TO THE POLYETHYLENE ENCASEMENT FROM EXCESSIVE HANDLING, THE POLYWRAP SHALL BE INSTALLED AROUND THE BARREL OF THE DUCTILE IRON PIPE AT ITS FINAL LOCATION ALONG THE TRENCHLINE. THE POLYETHYLENE ENCASED PIPE SHALL BE LIFTED USING A FABRIC TYLE SLING OR A SUITABLY PADDED CABLE OR CHAIN TO PREVENT DAMAGE TO THE POLYETHYLENE.
  - Q. THE CONTRACTOR SHALL TAKE ALL NECESSARY COMPACTION TESTS WHILE THE WATERLINE TRENCH IS BEING BACKFILLED AND WHILE THE SUBBASE/ BASECOURSE IS BEING PLACED. IF THE TEST RESULTS INDICATE THAT ADDITIONAL COMPACTION IS REQUIRED, THE CORRECTIVE WORK SHALL BE COMPLETED BEFORE ANY ADDITIONAL TRENCH EXCAVATION OR PLACING OF SUBBASE/ BASECOURSE IS ALLOWED.
- THE CONTRACTOR SHALL RETAIN THE SERVICES OF A REGISTERED GEOTECHNICAL ENGINEER FOR QUALITY CONTROL. THE COMPACTION TEST RESULTS SHALL BE CERTIFIED BY THE GEOTECHNICAL ENGINEER AND SUBMITTED TO THE DEPARTMENT OF WATER, STATE HIGHWAYS DIVISION (FOR WORK DONE WITHIN STATE R/W) AND THE DEPARTMENT OF PUBLIC WORKS (FOR WORK DONE WITHIN COUNTY R/W). THE GEOTECHNICAL ENGINEER SHALL CERTIFY THAT THE COMPACTION RESULTS MEET THE REQUIREMENTS OF THE CURRENT STANDARD SPECIFICATIONS FOR ROAD AND BRIDGE CONSTRUCTION.
  - R. THE CONTRACTOR SHALL CONNECT ALL EXISTING CONSUMER PIPING TO THE NEW SERVICE LATERALS. THE DEPARTMENT OF WATER WILL TRANSFER THE EXISTING WATER METERS ONLY.
  - S. ALL FITTINGS SHALL BE MECHANICAL JOINT (MJ) AT EACH END UNLESS OTHERWISE NOTED. 'MEGALUG' RETAINER GLANDS SHALL BE USED WITH ALL MECHANICAL JOINT FITTINGS AND VALVES USED IN CONNECTING NEW WATER MAINS TO EXISTING WATER MAINS UNLESS OTHERWISE NOTED.
  - T. ALL WATER VALVES THAT WILL BE ABANDONED IN PLACE SHALL BE PLACED IN THE 'CLOSED' POSITION. REMOVE TOP SECTION OF VALVE BOX AND CONCRETE SETTLEMENT SLAB. FILL REMAINDER OF VALVE BOX WITH CONCRETE. PLACE BACKFILL AND REPAIR PAVEMENT SECTION TO APPLICABLE STATE OR COUNTY STANDARDS. BACKFILL TO FINISH GRADE IN ROAD SHOULDER AREA.
  - U. THE CONTRACTOR SHALL OBTAIN ALL APPLICABLE DEPARTMENT OF HEALTH PERMITS PRIOR TO THE START OF CONSTRUCTION. PERMITS INCLUDE, BUT ARE NOT LIMITED TO, NATIONAL POLLUTION DISCHARGE ELIMINATION SYSTEM (NPDES) PERMITS FOR STORM WATER, HYDROSTATIC TEST, DEWATERING, AND FOR CONSTRUCTION ACTIVITIES, INCLUDING CLEARING, GRADING, AND EXCAVATION, THAT RESULT IN THE DISTURBANCE OF EQUAL TO OR GREATER THAN ONE (1) ACRE OF TOTAL LAND AREA.

THE CONTRACTOR SHALL BE RESPONSIBLE FOR THE PROPER DISPOSAL OF STORM WATER DISCHARGES AND EFFLUENT ASSOCIATED WITH CONSTRUCTION ACTIVITIES INCLUDING HYDROTRESTING AND DISINFECTION OPERATIONS, TO SAFEGUARD PUBLIC HEALTH AND SAFETY IN ACCORDANCE WITH APPLICABLE DEPARTMENT OF HEALTH REQUIREMENTS. ALL PERMITS AND LICENSES FOR STORM WATER AND CONSTRUCTION WATER DISPOSAL, INCLUDING ALL APPLICATION, CHARGES, FEES, AND TAXES, ARE THE RESPONSIBILITY OF THE CONTRACTOR.

  - V. THE CONTRACTOR IS RESPONSIBLE FOR DEWATERING TRENCH AS NECESSARY WHERE GROUNDWATER IS ENCOUNTERED. ALL ASSOCIATED COSTS FOR DEWATERING SHALL BE BORNE BY THE CONTRACTOR.
  - W. THE USE OF KNOWN SEWER PUMP TRUCKS IS PROHIBITED FOR DOW PROJECTS FOR ANY USE, INCLUDING BUT NOT LIMITED TO DEWATERING AND TESTING OF NEW FACILITIES.
  - X. THE CONTRACTOR SHALL VERIFY OUTSIDE DIAMETER OF ALL EXISTING ASBESTOS-CEMENT (AC) WATERLINES TO BE CONNECTED. CONTRACTOR SHALL VERIFY USE OF PROPER GASKETS PRIOR TO CONNECTION. AC PIPE AND GASKET INFORMATION SHALL BE SUBMITTED TO ENGINEER FOR APPROVAL.
  - Y. ALL REMOVAL, DISPOSAL AND CONNECTION WORK THAT INVOLVES ASBESTOS PIPE/MATERIAL SHALL BE DONE IN THE PRESENCE OF OR BY A LICENSED ASBESTOS CONTRACTOR.
  - Z. THE LICENSED ASBESTOS CONTRACTOR SHALL SUBMIT THEIR PLAN FOR ALL ASSOCIATED REMOVAL, DISPOSAL AND CONNECTION WORK FOR THE PROJECT TO DOW FOR REVIEW AND APPROVAL PRIOR TO CONDUCTING THE WORK.
  - AA. ALL CONNECTIONS TO EXISTING AC PIPE SHALL BE AT THE NEAREST AC PIPE JOINT. AC PIPE SHALL BE REMOVED BY ENTIRE LENGTH(S) TO FACILITATE THE CONNECTION. CUTTING OF AC PIPE IS PROHIBITED.
  - AB. THE CONTRACTOR SHALL FOLLOW ALL APPLICABLE OSHA, HIGH AND FEDERAL REGULATIONS IN HANDLING AND DISPOSAL OF ASBESTOS-CEMENT PIPE. DISPOSAL OF THE PIPE SHALL BE AT AN APPROVED ASBESTOS MATERIAL DISPOSAL SITE.
  - AC. ALL WATERWORKS BRASS FITTINGS SHALL BE IN COMPLIANCE WITH THE AMENDED SECTION 1417 OF 'SAFE DRINKING WATER ACT (SDWA)' WHICH TAKES EFFECT ON JANUARY 4, 2014. THE AMENDMENT INTRODUCES A CHANGE TO THE DEFINITION OF 'LEAD-FREE' BY REDUCING LEAD CONTENT FROM 8% TO A WEIGHTED AVERAGE OF NOT MORE THAN 0.25% IN THE WETTED SURFACE MATERIAL. ALL WATERWORKS BRASS FITTINGS INSTALLED FOR POTABLE WATER SERVICE ON JANUARY 4, 2014 AND BEYOND SHALL CONFORM TO THE AMENDED DEFINITION OF 'LEAD-FREE.'
  - AD. AS INDICATED IN SECTION 211 OF WATER SYSTEM STANDARDS - BRASS PRODUCTS, ALL BRASS FITTINGS SHALL CONFORM TO NSF STANDARD 61 AND SECTION 1417 OF THE SAFE DRINKING WATER ACT (SDWA). IN ADDITION, ALL BRASS FITTINGS SHALL CONFORM TO NSF STANDARD 372.
  - AE. CONTRACTOR SHALL INSTALL WATER FACILITIES ONLY AFTER REACHING FINAL SUBGRADE OR HIGHER. THE DEPARTMENT OF WATER WILL NOT ALLOW INSTALLATION OF ANY WATER FACILITIES UNTIL THE FINAL SUBGRADE LAYER AT MINIMUM HAS BEEN ACHIEVED.
  - AF. PRIOR TO INSTALLATION OF NEW WATER LINES AND /OR FACILITIES, THE CONTRACTOR SHALL HAVE ALL FACILITIES SURVEYED AND STAKED OUT BY A LICENSED SURVEYOR AND THE CONTRACTOR SHALL EXPOSE, VERIFY, AND BACKFILL ALL EXISTING UNDERGROUND UTILITIES AND STRUCTURES IN CLOSE PROXIMITY TO CROSSINGS AND CONNECTIONS PRIOR TO EXCAVATION OF PIPELINE TRENCH. CONTRACTOR SHALL PROVIDE THE LICENSED SURVEYOR CUT SHEET AND THE PROBING INFORMATION TO THE DOW CONSTRUCTION ENGINEER FOR REVIEW AND APPROVAL BEFORE MOVING FORWARD WITH INSTALLATION VIA THE SUBMITTAL REVIEW PROCESS.
  - AG. THE DEPARTMENT SHALL BE PROVIDED TWENTY (20) WORKING DAYS FOR ALL SUBMITTAL REVIEWS FROM THE TIME OF SUBMISSION BY THE CONTRACTOR.

**GENERAL:**

- A. WORKMANSHIP AND MATERIALS SHALL CONFORM TO ACI 318-05 BUILDING CODE REQUIREMENTS FOR REINFORCED CONCRETE AND COMMENTARY. HOWEVER, WHERE REFERENCE IS MADE TO PERFORMANCE CONFORMING TO OTHER STANDARDS THE MORE STRINGENT SHALL APPLY.
  - B. THE CONTRACTOR SHALL COMPARE ALL THE CONTRACT DOCUMENTS WITH EACH OTHER AND REPORT IN WRITING TO THE DOW ALL INCONSISTENCIES AND OMISSIONS.
  - C. THE CONTRACTOR SHALL TAKE FIELD MEASUREMENTS AND VERIFY FIELD CONDITIONS AND SHALL COMPARE SUCH FIELD MEASUREMENTS AND CONDITIONS WITH THE DRAWINGS BEFORE COMMENCING WORK. IN WRITING TO OFFICER-IN-CHARGE ALL INCONSISTENCIES AND OMISSIONS.
  - D. THE CONTRACTOR SHALL BE RESPONSIBLE FOR COORDINATING THE WORK OF ALL TRADES.
  - E. THE CONTRACTOR SHALL BE RESPONSIBLE FOR MEANS AND METHODS OF CONSTRUCTION, WORKMANSHIP AND JOB SAFETY.
  - F. THE CONTRACTOR SHALL PROVIDE TEMPORARY SHORING AND BRACING AS REQUIRED FOR STABILITY OF STRUCTURAL MEMBERS AND SYSTEMS.
  - G. CONSTRUCTION LOADING SHALL NOT EXCEED DESIGN LIVE LOAD UNLESS SPECIAL SHORING IS PROVIDED. PERMITTED CONSTRUCTION LOADS SHALL BE PROPERLY REDUCED IN AREAS WHERE THE STRUCTURE HAS NOT ATTAINED FULL DESIGN STRENGTH.
  - H. THE CONTRACTOR SHALL BE RESPONSIBLE FOR PROTECTION OF UNDERGROUND STRUCTURES AND UTILITIES DURING THE CONSTRUCTION PERIOD. ANY DAMAGED OR DETERIORATED PROPERTY SHALL BE RESTORED TO THE CONDITION PRIOR TO THE BEGINNING OF WORK OR BETTER AT NO COST TO BWS.
  - I. DETAILS NOTED AS TYPICAL ON THE STRUCTURAL DRAWINGS SHALL APPLY IN ALL CONDITIONS UNLESS SPECIFICALLY SHOWN OR NOTED OTHERWISE.
- CONCRETE REPAIR:**
- A. REMOVE SPALLS, DELAMINATED, OR DETERIORATED CONCRETE TO SOUND SUBSTRATE AND BEYOND THE EXTENT OF CORRODED REINFORCING.
  - B. FULLY EXPOSE AND REMOVE CORROSION FROM REINFORCING STEEL AND COAT WITH BONDING AGENT.
  - C. PROPERLY CLEAN AND PREPARE CONCRETE SUBSTRATE. REPAIR CONCRETE PER MANUFACTURER'S SPECIFICATIONS.
  - D. SCRUB REPAIR MORTAR INTO REPAIR SURFACE PRIOR TO INSTALLATION OF REPAIR-SEE MANUFACTURER'S RECOMMENDATIONS.
  - E. APPLY REPAIR MORTAR INTO REPAIR AREA BY FORCING MATERIAL AGAINST EDGE OR REPAIR AREA WORKING TOWARD CENTER.
  - F. FINISH AND CURE AS DESCRIBED IN SPECIFICATION.

**SURFACE PREPARATION NOTES FOR SPALL REPAIRS:**

- A. DETERIORATED CONCRETE SHALL BE REMOVED DOWN TO SOUND SUBSTRATE, OR TO THE SPECIFIED DEPTH AS NOTED IN THE SPALL REPAIR DETAILS. SAWCUT ALL EDGES MINIMUM OF 1/2" DEEP. NO FEATHERING OF PATCHING MATERIAL IS ALLOWED. AVOID CUTTING ANY REINFORCING STEEL WHEN SAWCUTTING. THE EXPOSED CONCRETE SHALL BE ROUGHENED TO A 1/8" AMPLITUDE AND SHALL BE CLEANED AND FREE OF LAITANCE, DUST AND OTHER BOND INHIBITING MATERIALS.
- B. ALL REINFORCING STEEL DAMAGED DUE TO THE CONTRACTOR'S OPERATIONS SHALL BE REPAIRED BY THE CONTRACTOR AT HIS/HER EXPENSE AND TO THE SATISFACTION OF THE ENGINEER.
- C. ALL LOOSE, SOFT, HONEY-COMBED, DISINTEGRATED CONCRETE, PLUS 3/4" INCH MINIMUM DEPTH OF CONCRETE BEYOND THE BACK FACE OF THE REBAR WITHIN THE SPALL AREA SHALL BE REMOVED.
- D. AFTER COMPLETION OF THE REMOVAL OPERATION, THE ENGINEER WILL RESOUND THE AREAS TO ENSURE THAT ONLY SOUND CONCRETE REMAINS.
- E. CLEANING SHALL PRECEDE APPLICATION OF THE PATCHING MATERIAL BY NOT MORE THAN 24 HOURS.

**BONDING AGENT:**

- A. AFTER THE CONCRETE SURFACES HAVE BEEN PREPARED AND CLEANED, AND IMMEDIATELY BEFORE PLACING THE CONCRETE PATCHING, A COAT OF BONDING AGENT SHALL BE APPLIED. THE SURFACE SHALL RECEIVE A THOROUGH AND EVEN COATING, AND EXCESS BONDING AGENT SHALL NOT BE PERMITTED TO COLLECT IN POCKETS. THE RATE OF PROGRESS IN APPLYING THE BONDING AGENT SHALL BE LIMITED SO THAT IT DOES NOT BECOME DRY BEFORE IT IS COVERED WITH THE CONCRETE PATCHING. SHOULD THE SURFACE OF THE BONDING AGENT DRY, THE DRIED BONDING AGENT SHALL BE COMPLETELY REMOVED AND FRESH BONDING AGENT APPLIED. REMOVAL SHALL BE BY SANDBLASTING OR BY ANOTHER PROCEDURE APPROVED BY THE ENGINEER. THE REMOVAL OF BONDING AGENT SHALL BE AT THE EXPENSE OF THE CONTRACTOR.
- B. THE BONDING AGENT SHALL PROVIDE CORROSION PROTECTION TO THE REINFORCING STEEL AND SHALL ACT AS A BONDING AGENT FOR THE FRESH PATCHING MORTAR. ALL EXPOSED REINFORCING STEEL SHALL RECEIVE TWO (2) COATS AT 20 MILS EACH, TOTAL OF 40 MILS. THE CONCRETE SURFACE SHALL RECEIVE ONE (1) COAT AT 20 MILS. FOLLOW MANUFACTURER'S SPECIFICATIONS FOR RECOMMENDED TIME BETWEEN APPLICATION OF BONDING AGENT AND PATCHING MORTAR. THE MINIMUM BOND STRENGTH PROVIDED BY THE BONDING AGENT SHALL BE 2,000 PSI AFTER 14 DAYS (ASTM C-882).

**POLYMER MODIFIED PATCHING MORTAR:**

- A. PATCHING MORTAR SHALL BE A POLYMER MODIFIED MORTAR, HAVE HIGH ABRASION RESISTANCE AND SHALL BE SUITABLE FOR HORIZONTAL, VERTICAL AND OVERHEAD SURFACES. THE MINIMUM BOND STRENGTH PROVIDED BY THE PATCHING MORTAR SHALL BE 2,000 PSI AFTER 28 DAYS (ASTM C-882). REFER TO MANUFACTURER'S SPECIFICATIONS FOR PREPARATION AND APPLICATION GUIDANCE.
- B. CURING: AS PER ACR RECOMMENDATIONS FOR PORTLAND CEMENT CONCRETE, CURING IS REQUIRED. FOLLOW THE MANUFACTURER'S RECOMMENDATION FOR CURING MATERIAL AND PROCEDURE.
- C. MULTIPLE LIFTS: FOLLOW THE MANUFACTURER'S LIMITATIONS FOR MAXIMUM THICKNESS FOR APPLICATION OF PATCHING MORTAR. IF THE REQUIRED THICKNESS OF A REPAIR IS GREATER THAN THE SINGLE APPLICATION LIMIT, MULTIPLE LIFTS ARE REQUIRED. LARGE UNCONCRETED OR OVERHEAD REPAIRS MAY ALSO REQUIRE MULTIPLE LIFTS. IF SUCCESSIVE LIFTS ARE TO BE APPLIED, ROUGHEN THE SURFACE OF THE PREVIOUS LIFT AND APPLY SUBSEQUENT LIFTS WITHIN THE TIME PERIOD, BOTH AS RECOMMENDED BY THE MANUFACTURER.

**ABBREVIATIONS:**

AC	ASPHALT CONCRETE
BLDG. BLDG.	BUILDING
CLK.	BLOCK
CLR.	CLEAR
CONC.	CONCRETE
CONT.	CONTINUOUS
CRM	CEMENT ROCK MASONRY
DIA.	DIAMETER
DOW	DEPARTMENT OF WATER
ELEC	ELECTRICAL
ELEV	ELEVATION
EMBED	EMBEDMENT
EXIST. (E)	EXISTING
GALV.	GALVANIZED
HGD	HOT DIP GALVANIZED
HORIZ	HORIZONTAL
I.D.	INSIDE DIAMETER
L	LENGTH
LBP	LEAD-BASED PAINT
LCP	LEAD-CONTAINING PAINT
LLH	LONG LEG HORIZONTAL
MANUF	MANUFACTURER
MAX	MAXIMUM
MIG	MILLION GALLON
MH	MANHOLE
MIN.	MINIMUM
O.C.	ON CENTER
O.D.	OUTSIDE DIAMETER
PCB	POLYCHLORINATED BIPHENYLS
PVC	POLYVINYL CHLORIDE
SECT	SECTION
SIM	SIMILAR
SQ.	SQUARE
SPEC	SPECIFICATION
S.S.	STAINLESS STEEL
TEL	TELECOMMUNICATIONS
THK.	THICK
TYP.	TYPICAL
W/	WITH
&	AND
#	NUMBER
C	CENTER LINE
Ø	DIAMETER
≥	GREATER OR EQUAL TO
%	PERCENT

REVISION	DATE	DESCRIPTION	BY	APPROVED
<b>REHABILITATE PAUA VALLEY TANK #1</b>				
<b>WATER CONSTRUCTION AND STRUCTURAL NOTES, ABBREVIATIONS</b>				
		APPROVED: _____ DATE _____ COUNTY ENGINEER (DEPT. PUBLIC WORKS, COUNTY OF KAUAI) APPROVED: _____ DATE _____ ASSISTANT COUNTY ENGINEER (DEPT. OF WATER, COUNTY OF KAUAI)		
Expiration Date of License 04-30-20				
KAI HAWAII, INC. HONOLULU, OAHU, HAWAII, 96813				
DRAWING NO. T-2		DESIGNED BY: DY DRAWN BY: CAD DATE: 8-21-18 SHEET 2 OF 8 SHEETS		

**RESERVOIR WATER (CONTAINING PCB) DISCHARGE NOTES:**

A. THE CONTRACTOR SHALL SUBMIT A RISK-BASED PCB CLEANUP APPROVAL APPLICATION IN ACCORDANCE WITH THE REQUIREMENTS OF THE TOXIC SUBSTANCES CONTROL ACT (TSCA, 40 CFR 761.61(c)), AND OBTAIN APPROVAL FROM THE ENVIRONMENTAL PROTECTION AGENCY (EPA) PRIOR TO DISCHARGING THE PCB-CONTAINING STORAGE WATER FROM THE EXISTING RESERVOIR AND DISPOSING OF PCB WASTE.

B. DISCHARGE LOCATION AND SCHEDULE:  
 1. THE WATER IN THE RESERVOIR SHALL BE DISCHARGED INTO THE PAUA DRAINAGE DITCH AT A RATE TO ALLOW THE DISCHARGED WATER TO INFILTRATE INTO THE GROUND SURFACE BEFORE REACHING APPROXIMATELY 300 FEET DOWNSTREAM OF THE RESERVOIR DISCHARGE PIPE.  
 2. THE DISCHARGE RATE WILL BE APPROXIMATELY 14,000 GALLONS/DAY FOR 25 DAYS.

C. DISCHARGE PROCEDURE AND SAMPLING PLAN:  
 1. TEST WATER AT EFFLUENT LINE SAMPLING TAP WHICH DRAWS WATER FROM THE BOTTOM REGION OF THE RESERVOIR WATER TO CONFIRM THE PCB-CONCENTRATION IS WITHIN ALLOWABLE LIMIT TO ALLOW WATER TO BE DISCHARGED WITHOUT ANY FILTRATION. CONSULT WITH USEPA AND HDOH ABOUT PCB CONCENTRATION AND OBTAIN APPROVAL TO DISCHARGE. EPA METHOD 505 WILL BE USED FOR WATER TESTING. THE REQUIRED SAMPLE CONTAINER PER SAMPLE IS TWO, ONE-LITER GLASS AMBER BOTTLE. RECOMMEND COLLECTING TWO SAMPLES FOR FIELD QUALITY CONTROL.  
 2. IF THE PCB CONCENTRATION IN WATER FROM STEP 1 IS BELOW ALLOWABLE UPPER LIMIT (0.5 µg/L), SLOWLY DISCHARGE WATER FROM THE RESERVOIR CLEANOUT DRAIN LINE TO MINIMIZE THE MIXING OF THE WATER WITH THE PCB-CONTAINING "SCUM" LAYER ON THE WATER SURFACE. DRAIN CONTINUOUSLY AT A SLOW RATE UNTIL THE WATER LEVEL REACHES A DEPTH OF APPROXIMATELY 2 FEET.  
 3. CONNECT PIPING AT END OF DRAINAGE DISCHARGE PIPE FROM RESERVOIR BY REMOVING THE EXISTING FLAP GATE VALVE AND CONNECT TWO LIQUID PHASE ABSORBER UNIT DRUMS CONTAINING VIRGIN ACTIVATED CARBON 8 x 12 MESH DESIGN TO ABSORB PCB. THE DISCHARGE RATE FOR TWO UNITS CONNECTED IN PARALLEL IS 10 GALLONS PER MINUTE. THIS ABSORBER UNIT DRUM IS A MANUFACTURED ASSEMBLY AND CAN BE PURCHASED FROM THE MANUFACTURERS LISTED IN THE SPECIAL PROVISIONS.  
 4. TAKE A FOLLOW-UP EFFLUENT WATER SAMPLE, DISCHARGED FROM THE ACTIVATED CARBON FILTER UNITS TO CONFIRM THE PCB-CONCENTRATION IS BELOW THE ALLOWABLE LIMIT, 0.5 µg/L, AND ANALYZE USING EPA METHOD 505. THE REQUIRED SAMPLE CONTAINER PER SAMPLE IS 2 X 1L GLASS AMBER. IF THE PCB RESULT IS GREATER THAN 0.5 µg/L, THE CONTRACTOR SHALL STOP DISCHARGING WATER AND REPLACE GRANULAR ACTIVATED CARBON OR ADD AN ADDITIONAL TREATMENT SUCH AS BAG FILTERS WITH 0.5 µM AFTER CARBON FILTRATION. REPEAT THIS STEP UNTIL THE PCB-CONCENTRATION IS BELOW THE ALLOWABLE LIMIT. RELEASE AS MUCH WATER AS WILL DRAIN BY GRAVITY. CLEAN UP THE REMAINING RESIDUE.  
 5. PERFORM TOXICITY CHARACTERISTIC LEACHING PROCEDURE (TCLP) ANALYSIS, METHOD 1311, ON THE ACTIVATED CARBON FILTER DRUM UNITS TO DETERMINE IF THE WASTE IS HAZARDOUS OR NON-HAZARDOUS. IF PCB CONCENTRATION IS DETERMINED TO BE LESS THAN 50 PPM, THE ACTIVATED CARBON FILTER DRUM UNITS CAN BE DISPOSED OF AT THE MUNICIPAL LANDFILL WITH NO SPECIAL REQUIREMENTS AFTER ALL THE WATER HAS BEEN FILTERED.  
 6. IF THE PCB CONCENTRATION IS DETERMINED TO BE GREATER THAN 50 PPM, DISPOSE OF THE ACTIVATED CARBON FILTER DRUM UNITS AS PERMITTED BY STATE AND FEDERAL LAW BASED ON THE PCB CONCENTRATION OF THE SURFACE FILTER MATERIAL, ABSORBENT AND CARBON FILTER TESTING.

D. SAMPLE COLLECTION AND LABORATORY ANALYSIS:  
 1. COLLECTED SAMPLES SHALL BE STORED BETWEEN 0 – 4 CELSIUS UNTIL THE SAMPLES ARE DELIVERED TO THE LABORATORY. THE SAMPLES SHALL BE STORED AT THE REQUIRED TEMPERATURE IMMEDIATELY AFTER COLLECTION TO PRESERVE THE CONDITION AT THE TIME OF COLLECTION. THE SAMPLER SHALL COORDINATE FURTHER WITH AN ANALYTICAL LABORATORY TO CONFIRM THE TESTING METHOD, SAMPLE AMOUNT, AND SAMPLE PRESERVATION REQUIREMENTS.

E. SITE RESTORATION  
 1. AFTER DISCHARGE IS COMPLETE, RESTORE PIPING AND GRADE TO PREVIOUS CONDITION OR BETTER, ACCEPTABLE TO DOW.  
 2. BACKFILL AND COMPACT SOIL AND ROCKS TO MINIMIZE FUTURE EROSION IN STREAM BED.

**BEST MANAGEMENT PRACTICES (BMP) NOTES:**  
 A. **GENERAL**  
 1. THE CONTRACTOR IS REMINDED OF THE REQUIREMENTS OF SECTION 209-WATER POLLUTION AND EROSION CONTROL AND SECTION 620-DUST CONTROL, IN THE "HAWAII STANDARD SPECIFICATIONS FOR ROAD AND BRIDGE CONSTRUCTION 2005." AS AMENDED. SECTION 209 DESCRIBES BUT IS NOT LIMITED TO: SUBMITTAL REQUIREMENTS; SCHEDULING OF A WATER POLLUTION AND EROSION CONTROL CONFERENCE WITH THE ENGINEER; CONSTRUCTION REQUIREMENTS; METHOD OF MEASUREMENT; AND BASIS OF PAYMENT. NO WORK SHALL COMMENCE WITHOUT A BMP PLAN APPROVED BY THE DEPARTMENT OF HEALTH.  
 2. THE CONTRACTOR SHALL FOLLOW THE GUIDELINES IN THE "INTERIM BEST MANAGEMENT PRACTICES MANUAL FOR CONSTRUCTION SITES FOR COUNTY OF KAUAI" APRIL 2004 IN DEVELOPING, INSTALLING AND MAINTAINING THE BEST MANAGEMENT PRACTICES (BMPs) FOR THE PROJECT. THE CONTRACTOR MAY SUBMIT ALTERNATE METHODS TO THE ENGINEER FOR ACCEPTANCE.  
 3. THE CONTRACTOR SHALL KEEP A COPY OF THE APPROVED BMP PLAN, NOI, ETC. ON THE PROJECT SITE. THE BMP PLAN SHALL BE UPDATED TO REFLECT ANY CHANGES MADE DURING THE COURSE OF CONSTRUCTION FOR THE DURATION OF THE PROJECT.  
 4. THE COUNTY ENGINEER MAY ASSESS LIQUIDATED DAMAGES OF UP TO \$27,500 FOR NON-COMPLIANCE OF EACH BMP REQUIREMENT AND EACH REQUIREMENT STATED IN SECTION 209, FOR EVERY DAY OF NON-COMPLIANCE. THERE IS NO MAXIMUM LIMIT ON THE AMOUNT ASSESSED PER DAY.  
 5. THE COUNTY ENGINEER MAY DEDUCT THE COST FROM THE PROGRESS PAYMENT FOR ALL CITATIONS RECEIVED BY THE DEPARTMENT FOR NON-COMPLIANCE, OR THE CONTRACTOR / OWNER SHALL REIMBURSE THE STATE, AND / OR COUNTY FOR THE FULL AMOUNT OF THE OUTSTANDING COST INCURRED BY THE STATE AND / OR COUNTY.

B. **TEMPORARY EROSION CONTROL MEASURES:**  
 1. PRIOR TO CLEARING LAND FOR GRADING, ALL TEMPORARY EROSION CONTROL MEASURES, SUCH AS SILT FENCES AND CONSTRUCTION ACCESS SHALL BE INSTALLED.  
 2. ENTRY/EXIT DRIVEWAYS SHALL BE ESTABLISHED PRIOR TO CLEARING OPERATIONS. DRIVEWAYS SHALL BE A MINIMUM OF 12 FEET WIDE AND 50 FEET LONG, 6" THICK OF 2-3 INCH WASHED STONES OR CRUSHED ROCK.  
 3. OPENING AND CLEARING OF LAND FOR GRADING SHALL BE PERFORMED INCREMENTALLY TO MINIMIZE EROSION POTENTIAL.

4. AREAS NOT WITHIN THE LIMITS OF CLEARING AND GRUBBING SHALL REMAIN VEGETATED DURING GRADING OPERATIONS.  
 5. SILT WHICH HAS ACCUMULATED ON SILT FENCE SHALL BE REMOVED AND DISPOSED OF ON A BI-WEEKLY BASIS.  
 6. STOCKPILES SHALL NOT BE LOCATED IN DRAINAGE WAYS OR OTHER AREAS ON CONCENTRATED FLOWS. SEDIMENT TRAPPING DEVICES SUCH AS FENCES, TRAPS, BASINS, OR BARRIERS SHALL BE USED AROUND THE BASE OF ALL STOCKPILES.  
 7. DUST CONTROL SHALL BE APPLIED TO REDUCE EMISSIONS. THE CONTRACTOR, AT HIS OWN EXPENSE, SHALL KEEP THE PROJECT AREA AND SURROUNDING AREA FREE FROM DUST NUISANCE. THE WORK SHALL BE IN CONFORMANCE WITH THE AIR POLLUTION CONTROL STANDARDS CONTAINED IN HAWAII ADMINISTRATIVE RULES: CHAPTER 11-60, "AIR POLLUTION CONTROL". CONTRACTOR SHOULD KEEP THE OPEN SITE WATERED DURING CONSTRUCTION HOURS.  
 8. SEDIMENT FENCES OR BARRIERS SHALL BE USED DOWN SLOPE OF ALL DISTURBED AREAS OR STOCKPILE AREAS.  
 9. ALL DISTURBED AREAS SHALL BE PERMANENTLY STABILIZED PRIOR TO REMOVING EROSION AND SEDIMENT MEASURES. ALL TEMPORARY EROSION AND SEDIMENT CONTROL MEASURES SHALL BE REMOVED WITHIN 30 DAYS AFTER FINAL SITE STABILIZATION OR AFTER THE TEMPORARY MEASURE ARE NO LONGER NEEDED. TRAPPED SEDIMENT AND AREAS OF DISTURBED SOIL WHICH RESULT FROM THE REMOVAL OF THE TEMPORARY MEASURE SHALL BE IMMEDIATELY AND PERMANENTLY STABILIZED.

C. **EROSION AND SEDIMENT CONTROL INSPECTION AND MAINTENANCE PRACTICES:**  
 1. THE CONTRACTOR SHALL INSPECT THE EROSION AND SEDIMENT CONTROL MEASURES AT LEAST TWICE A WEEK OR AFTER A 0.5 INCHES OF RAINFALL EVENT.  
 2. THE CONTRACTOR SHALL MAINTAIN THE EROSION AND SEDIMENT CONTROL MEASURES ACCORDING TO THE CONTRACT. IF A REPAIR IS NECESSARY, THE CONTRACTOR SHALL INITIATE THE REPAIRS WITHIN TWENTY-FOUR (24) HOURS AFTER THE INSPECTION SUCH AS:  
 a. WHEN SEDIMENT BUILDUP REACHES ONE-THIRD (1/3) THE HEIGHT OF THE SILT FENCE, THE CONTRACTOR SHALL REMOVE AND DISPOSE OF THE SEDIMENT BUILDUP FROM THE SILT FENCE.  
 b. WHEN TEARS ARE FOUND ON THE SILT FENCE, THE CONTRACTOR SHALL REPLACE THE FABRIC.  
 c. THE CONTRACTOR SHALL CHECK TO SEE IF THE FABRIC IS SECURELY ATTACHED TO THE FENCE POSTS AND TO SEE THAT THE FENCE POSTS ARE FIRMLY IN THE GROUND.  
 3. THE CONTRACTOR SHALL HAVE ITS PERSONNEL MAKE A MAINTENANCE INSPECTION REPORT PROMPTLY AFTER EACH INSPECTION. THE CONTRACTOR SHALL SELECT A MINIMUM OF THREE (3) PERSONNEL WHO WILL BE RESPONSIBLE FOR INSPECTION, MAINTENANCE, REPAIR ACTIVITIES, AND FILLING OUT THE INSPECTION AND MAINTENANCE REPORT. PERSONNEL SELECTED FOR THE INSPECTION AND MAINTENANCE RESPONSIBILITIES WILL RECEIVE TRAINING FROM THE CONTRACTOR. THE CONTRACTOR SHALL TRAIN THESE PERSONNEL IN THE INSPECTION AND MAINTENANCE PRACTICES NECESSARY FOR KEEPING THE EROSION AND SEDIMENT USE ON-SITE ACCORDING TO THE CONTRACT.

D. **WASTE DISPOSAL**  
 1. **WASTE MATERIALS:** ALL WASTE MATERIALS SHALL BE COLLECTED AND STORED IN A SECURELY LIDDED METAL DUMPSTER THAT DOES NOT LEAK. THE DUMPSTER SHALL MEET ALL LOCAL AND STATE SOLID WASTE MANAGEMENT REGULATIONS. ALL TRASH AND CONSTRUCTION DEBRIS FROM THE SITE SHALL BE DEPOSITED IN THE DUMPSTER. THE DUMPSTER SHALL BE EMPTIED A MINIMUM OF TWICE (2) PER WEEK OR AS OFTEN AS IS DEEMED NECESSARY. NO CONSTRUCTION WASTE MATERIALS SHALL BE BURIED ONSITE. THE CONTRACTOR'S SUPERVISORY PERSONNEL SHALL BE INSTRUCTED REGARDING THE CORRECT PROCEDURE FOR WASTE DISPOSAL. NOTICES STATING THESE PRACTICES SHALL BE POSTED IN THE OFFICE TRAILER AND THE CONTRACTOR SHALL BE RESPONSIBLE FOR SEEING THAT THESE PROCEDURES ARE FOLLOWED.  
 2. **HAZARDOUS WASTE:** ALL HAZARDOUS WASTE MATERIALS SHALL BE DISPOSED OF IN THE MANNER SPECIFIED BY LOCAL OR STATE REGULATIONS OR BY THE MANUFACTURER. THE CONTRACTOR'S SITE PERSONNEL SHALL BE INSTRUCTED IN THESE PRACTICES AND SHALL BE RESPONSIBLE FOR SEEING THAT THESE PRACTICES ARE FOLLOWED.  
 3. **SANITARY WASTE:** ALL SANITARY WASTE SHALL BE COLLECTED FROM THE PORTABLE UNITS A MINIMUM OF ONCE PER WEEK, OR AS REQUIRED.

E. **GOOD HOUSEKEEPING BEST MANAGEMENT PRACTICES**  
 1. **MATERIALS POLLUTION PREVENTION PLAN**  
 a. APPLICABLE MATERIALS OR SUBSTANCES LISTED BELOW ARE EXPECTED TO BE PRESENT ONSITE DURING CONSTRUCTION. OTHER MATERIALS AND SUBSTANCES NOT LISTED BELOW SHALL BE ADDED TO THE INVENTORY OF THE CONSTRUCTION CONTRACTOR'S SITE-SPECIFIC BMP PLAN.  
 CONCRETE FERTILIZERS  
 DETERGENTS PETROLEUM BASED PRODUCTS  
 PAINTS (ENAMEL & LATEX) CLEANING SOLVENTS  
 WOOD  
 b. MATERIAL MANAGEMENT PRACTICES SHALL BE USED TO REDUCE THE RISK OF SPILLS OR OTHER ACCIDENTAL EXPOSURE OF MATERIALS AND SUBSTANCES TO STORM WATER RUNOFF. AN EFFORT SHALL BE MADE TO STORE ONLY ENOUGH PRODUCTS AS IS REQUIRED TO DO THE JOB.  
 c. ALL MATERIALS STORED ONSITE SHALL BE STORED IN A NEAT, ORDERLY MANNER IN THEIR APPROPRIATE CONTAINERS AND IF POSSIBLE UNDER A ROOF OR OTHER ENCLOSURE.  
 d. PRODUCTS SHALL BE KEPT IN THEIR ORIGINAL CONTAINERS WITH THE ORIGINAL MANUFACTURER'S LABEL.  
 e. SUBSTANCES SHALL NOT BE MIXED WITH ONE ANOTHER UNLESS RECOMMENDED BY THE MANUFACTURER.  
 f. A PRODUCT SHALL BE USED UP COMPLETELY BEFORE DISPOSING OF THE CONTAINER.  
 g. MANUFACTURER'S RECOMMENDATIONS FOR PROPER USE AND DISPOSAL SHALL BE FOLLOWED.  
 h. THE CONTRACTOR SHALL CONDUCT A DAILY INSPECTION TO ENSURE PROPER USE AND DISPOSAL OF MATERIALS ONSITE.  
 2. **HAZARDOUS MATERIAL POLLUTION PREVENTION PLAN**  
 a. PRODUCTS SHALL BE KEPT IN ORIGINAL CONTAINERS UNLESS THEY ARE NOT RESEALABLE.  
 b. ORIGINAL LABELS AND MATERIAL SAFETY DATA SHEETS (MSDS) SHALL BE RETAINED AND

MADE AVAILABLE TO THE ENGINEER UPON REQUEST.  
 c. SURPLUS PRODUCTS SHALL BE DISPOSED OF ACCORDING TO MANUFACTURER'S INSTRUCTIONS OR LOCAL AND STATE RECOMMENDED REGULATIONS.

**3. ON-SITE AND OFF-SITE PRODUCTS SPECIFIC PRACTICES PLANS**

a. **PETROLEUM BASED PRODUCTS:** MONITOR ALL ON-SITE VEHICLES FOR LEAKS AND PERFORM REGULAR PREVENTIVE MAINTENANCE TO REDUCE THE CHANCE OF LEAKAGE. STORE PETROLEUM PRODUCTS IN TIGHTLY SEALED CONTAINERS WHICH ARE CLEARLY LABELED. APPLY ASPHALT SUBSTANCES USED ON-SITE ACCORDING TO THE MANUFACTURER'S RECOMMENDATION.  
 b. **FERTILIZERS:** APPLY FERTILIZERS USED ONLY IN THE MINIMUM AMOUNTS RECOMMENDED BY THE MANUFACTURER. ONCE APPLIED, WORK FERTILIZER INTO THE SOIL TO LIMIT EXPOSURE TO STORM WATER. STORAGE SHALL BE IN A COVERED SHED. TRANSFER THE CONTENTS OF ANY PARTIALLY USED BAGS OF FERTILIZER TO A SEALABLE PLASTIC BIN TO AVOID SPILLS.  
 c. **PAINTS:** SEAL AND STORE ALL CONTAINERS WHEN NOT REQUIRED FOR USE. DO NOT DISCHARGE EXCESS PAINT TO THE HIGHWAY DRAINAGE SYSTEM. DISPOSE PROPERLY ACCORDING TO MANUFACTURER'S INSTRUCTIONS OR STATE AND LOCAL REGULATIONS.  
 d. **CONCRETE TRUCKS:** WASH OUT OR DISCHARGE CONCRETE TRUCK DRUM WASH WATER ONLY AT A DESIGNATED SITE. DO NOT DISCHARGE WATER IN THE HIGHWAY DRAINAGE SYSTEM OR WATERS OF THE UNITED STATES. CONTACT DRINKING WATER BRANCH, DEPARTMENT OF HEALTH AT (808) 586-4285 TO RECEIVE PERMISSION TO DESIGNATE A DISPOSAL SITE. CLEAN DISPOSAL SITE AS REQUIRED OR AS REQUESTED BY THE OWNER'S REPRESENTATIVE.

**4. SPILL CONTROL PLAN**

a. POST A SPILL PREVENTION PLAN TO INCLUDE MEASURES TO PREVENT AND CLEANUP EACH SPILL.  
 b. THE CONTRACTOR SHALL BE THE SPILL PREVENTION AND CLEANUP COORDINATOR. DESIGNATE AT LEAST THREE SITE PERSONNEL WHO SHALL RECEIVE SPILL PREVENTION AND CLEANUP TRAINING. THESE INDIVIDUALS SHALL EACH BECOME RESPONSIBLE FOR A PARTICULAR PHASE OF PREVENTION AND CLEANUP. POST THE NAMES OF RESPONSIBLE SPILL PERSONNEL IN THE MATERIAL STORAGE AREA AND IN THE OFFICE TRAILER ONSITE.  
 c. CLEARLY POST MANUFACTURER'S RECOMMENDED METHODS FOR SPILL CLEANUP. MAKE SITE PERSONNEL AWARE OF THE PROCEDURES AND THE LOCATION OF THE INFORMATION AND CLEANUP SUPPLIES.  
 d. KEEP MATERIALS AND EQUIPMENT NECESSARY FOR SPILL CLEANUP IN THE MATERIAL STORAGE AREA ONSITE.  
 e. CLEANUP ALL SPILLS IMMEDIATELY AFTER DISCOVERY.  
 f. KEEP THE SPILL AREA WELL VENTILATED. PERSONNEL SHALL WEAR APPROPRIATE PROTECTIVE CLOTHING TO PREVENT INJURY FROM CONTACT WITH A HAZARDOUS SUBSTANCE.  
 g. REPORT SPILLS OF TOXIC HAZARDOUS MATERIAL TO THE APPROPRIATE STATE OR LOCAL GOVERNMENT AGENCY, REGARDLESS OF THE SIZE.

**F. NATIONAL POLLUTION DISCHARGE ELIMINATION SYSTEM (NPDES) REQUIREMENTS**

1. THE CONTRACTOR SHALL APPLY FOR, OBTAIN AND COMPLY WITH THE NATIONAL POLLUTION DISCHARGE ELIMINATION SYSTEM (NPDES) REQUIREMENTS FOR KAUAI DISTRICT OFFICE AT 3040 UMO STREET. DUE TO POTENTIAL COST IMPACTS, THE CONTRACTOR NEEDS TO BE AWARE OF THESE REQUIREMENTS.  
 2. THE CONTRACTOR SHALL OBTAIN AND COMPLY WITH THE NATIONAL POLLUTION DISCHARGE ELIMINATION SYSTEM (NPDES) PERMIT REQUIREMENTS FOR ALL PROJECTS WHICH WILL DISTURB ONE (1) ACRE OR MORE OF LAND. THE CONTRACTOR SHALL NOT START CONSTRUCTION UNTIL NOTICE OF GENERAL PERMIT COVERAGE (NGPC) IS RECEIVED FROM THE DEPARTMENT OF HEALTH, STATE OF HAWAII AND HAS SATISFIED ANY OTHER APPLICABLE REQUIREMENTS OF THE NPDES PERMIT PROGRAM.  
 3. THE CONTRACTOR SHALL COMPLETE AND SUBMIT A CONTRACTOR'S CERTIFICATION OF NPDES COMPLIANCE, INCLUDING COMPLETION OF THE BEST MANAGEMENT PRACTICE (BMP) CHECKLIST AND SUBMITTAL OF A WRITTEN BMP PLAN AND DRAWINGS, PRIOR TO ISSUANCE OF A GRADING PERMIT.

REVISION	DATE	DESCRIPTION	BY	APPROVED
----------	------	-------------	----	----------

**REHABILITATE PAUA VALLEY TANK #1**  
**BMP NOTES, RESERVOIR WATER DISCHARGE NOTES**

APPROVED:

COPY: DISTRICT  
 DEPT. PUBLIC WORKS, COUNTY OF KAUAI DATE

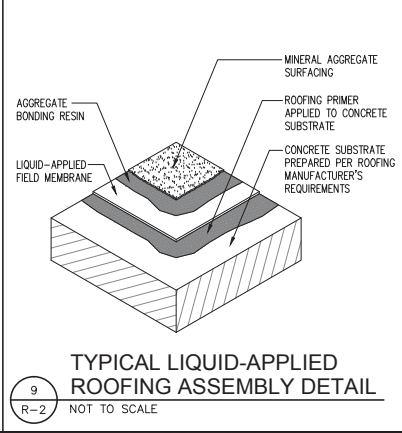
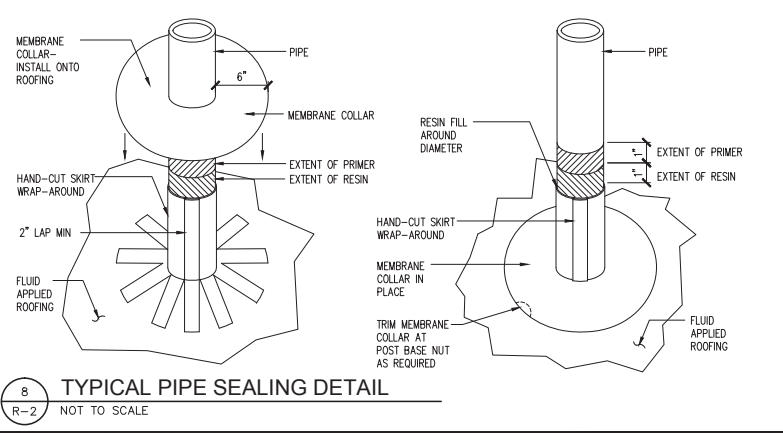
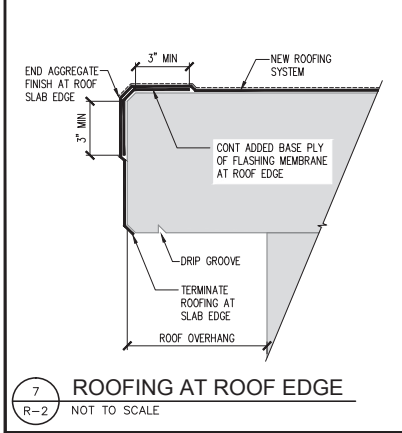
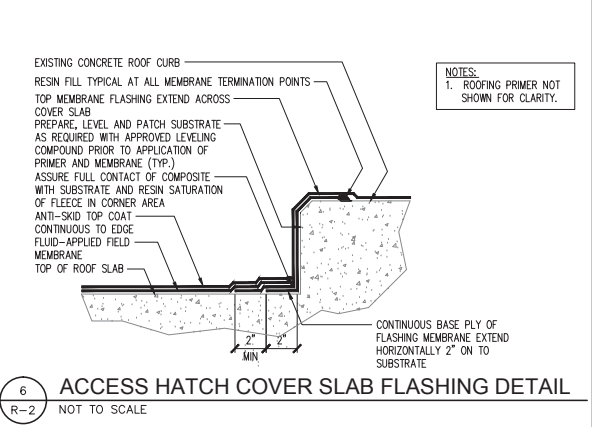
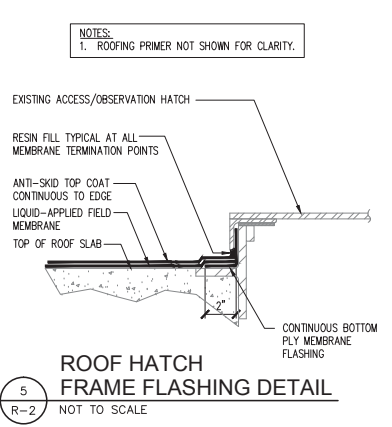
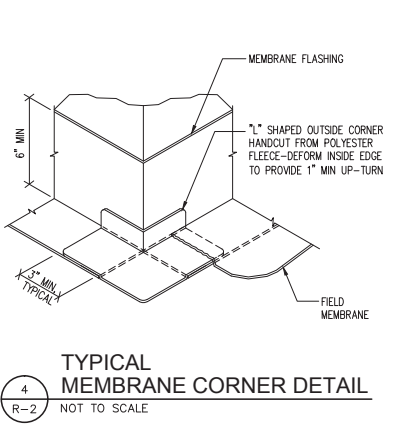
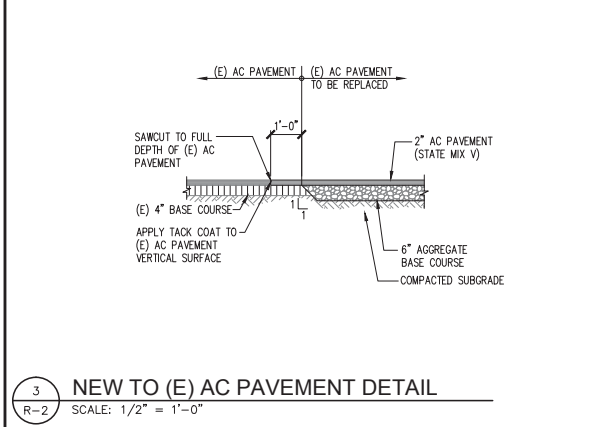
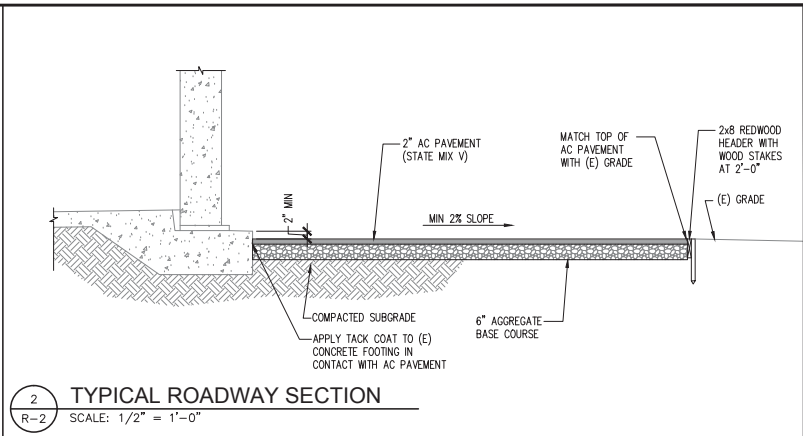
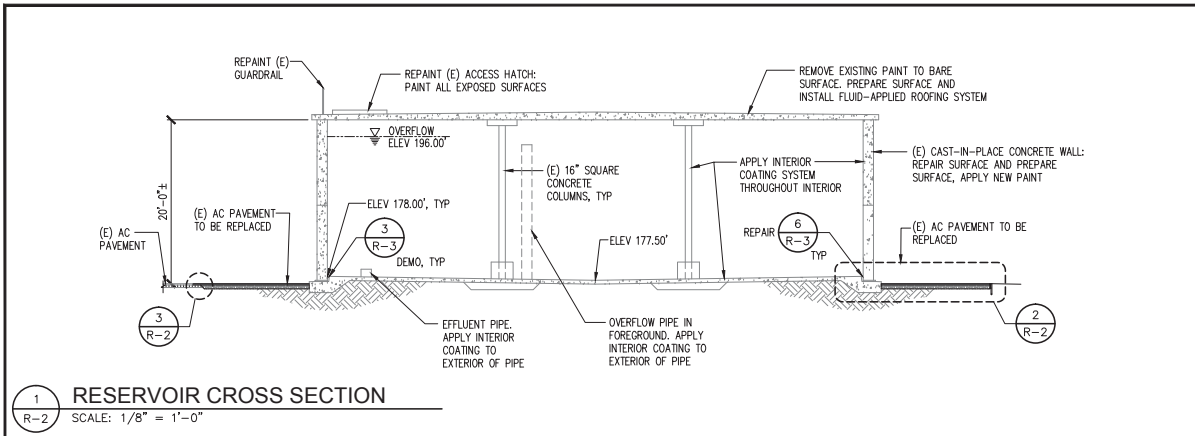
APPROVED:

ASSISTANT CHIEF ENGINEER  
 DEPT. OF WATER, COUNTY OF KAUAI DATE

This work was prepared by me or under my supervision and control. I am a duly licensed professional engineer and I am responsible for this program and will be under my observation

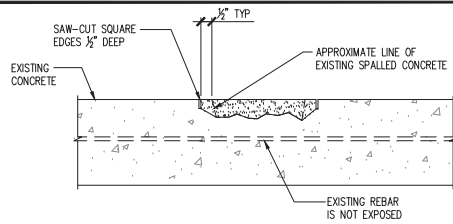
Expiration Date of License: 04-30-20





REVISION	DATE	DESCRIPTION	BY	APPROVED
<b>REHABILITATE PAUA VALLEY TANK #1</b>				
<b>RESERVOIR CROSS SECTION AND DETAILS</b>				
		APPROVED: _____ DATE _____		
		<small>COUNTY ENGINEER          COUNTY OF MAUI, COUNTY OF KAUAI</small>		
This work was prepared by me or under my supervision and construction to this project will be under my observation.		APPROVED: _____ DATE _____		
		<small>REGISTERED PROFESSIONAL ENGINEER          COUNTY OF MAUI, COUNTY OF KAUAI</small>		
Expiration Date of License: 04-30-20				
<small>KAI HAWAII, INC.          HONOLULU, OAHU, HAWAII, 96813</small>				
DRAWING NO. <b>R-2</b>		DESIGNED BY: DY		DRAWN BY: CAD
		DATE: 8-21-18		SHEET 5 OF 8 SHEETS

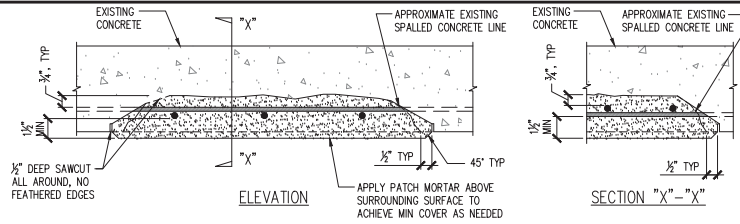
P:\4301-05\04\338 DWS - Rehabilitate Paua Valley Tank #1, 0.5 MG Concrete, Kakaia\04 - Drawings\Structural\AutoCAD\DWG\1808-08-08\_4339 DWS PaupValleyTank #1.dwg, 9/2/2018 1:34:09 PM, dypkomo



- NOTES:**
- CLEAN AND PREPARE CONCRETE ACCORDING TO THE SURFACE PREPARATION NOTES BELOW.
  - SUBSTRATE SHALL BE SATURATED SURFACE DRY (SSD) WITH NO STANDING WATER.
  - APPLY CORROSION INHIBITING BONDING AGENT TO ALL SURFACES TO BE PATCHED.
  - APPLY POLYMER MODIFIED PATCHING MORTAR TO REPAIR AREAS TO ORIGINAL FINISH LINES.
  - MAXIMUM PATCHING LAYER THICKNESS SHALL BE LIMITED TO MANUFACTURER'S SPECIFICATIONS.
  - PATCHED CONCRETE SHALL MATCH SURROUNDING AREA ELEVATION AND FINISH.

**1 TYPE I SPALL (WITHOUT EXPOSED REBAR) REPAIR DETAIL**

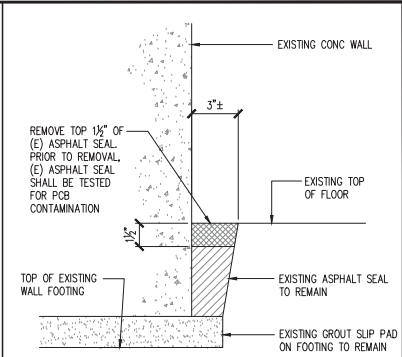
R-3 NOT TO SCALE



- NOTES:**
- CLEAN AND PREPARE CONCRETE ACCORDING TO THE SURFACE PREPARATION NOTES BELOW.
  - CLEAN ANY EXPOSED REINFORCEMENT BY SANDBLASTING OR WITH A WIRE BRUSH, REMOVING ALL CORROSION, OIL, DIRT AND ALL OTHER BOND INHIBITING AGENTS.
  - APPLY CORROSION INHIBITING BONDING AGENT TO ALL SURFACES TO BE PATCHED, INCLUDING REINFORCING STEEL.
  - APPLY POLYMER MODIFIED PATCHING MORTAR TO REPAIR AREAS TO ORIGINAL FINISH LINES, OR UNTIL A MINIMUM OF 1 1/2\"/>

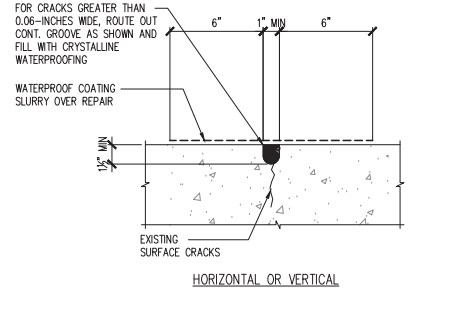
**2 TYPE II SPALL (WITH EXPOSED REBAR) REPAIR DETAIL**

R-3 NOT TO SCALE



**EXISTING SEALANT AT WALL JOINT DEMO**

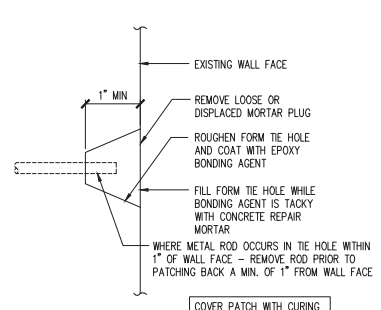
R-3 SCALE: 3\"/>



- CRACK REPAIR NOTES:**
- ROUTE OUT TO DIMENSIONS RECOMMENDED BY THE MANUFACTURER OR SHOWN TO SOUND CONCRETE.
  - WET EXPOSED CONCRETE SURFACE.
  - APPLY COAT OF CRYSTALLINE SLURRY TO WETTED SURFACE.
  - WHILE SLURRY IS STILL TACKY, FILL GROOVE WITH CRYSTALLINE MORTAR MIXED TO DRY PACK CONSISTENCY. COMPRESS TIGHTLY WITH PACKING DEVICE OR USE HAMMER AND BLOCK AND FINISH FLUSH WITH SURROUNDING SURFACE.
  - LIGHTLY WET REPAIR SURFACE, THEN APPLY SLURRY COAT OF CRYSTALLINE WATERPROOFING OVER AREA.
  - CURE REPAIR AREA AS RECOMMENDED BY MANUFACTURER.

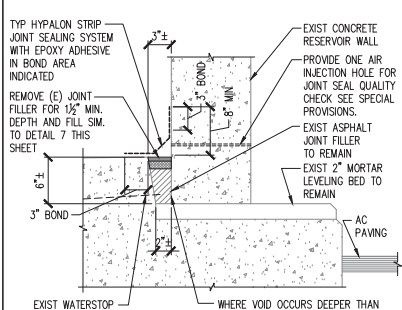
**TYPICAL ROUTING OF LARGER CRACK (0.06\"/>**

R-3 NOT TO SCALE



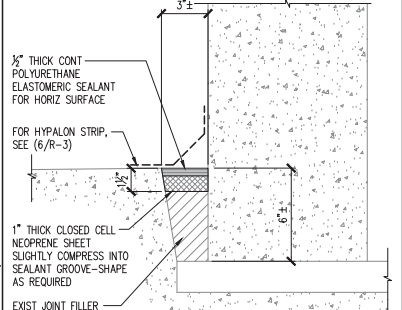
**5 FORM TIE HOLE REPAIR**

R-3 NOT TO SCALE



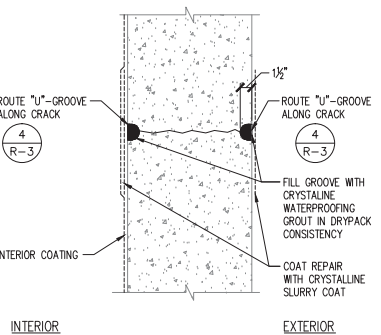
**6 WALL / FLOOR JOINT REHABILITATION**

R-3 SCALE 1 1/2\"/>



**7 WALL BASE SEALANT**

R-3 NOT TO SCALE



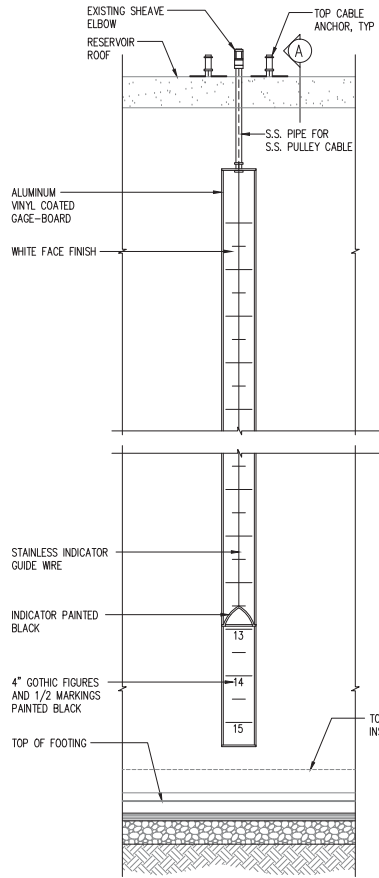
**8 WALL CRACK REPAIR AT LEAK**

R-3 SCALE 1 1/2\"/>

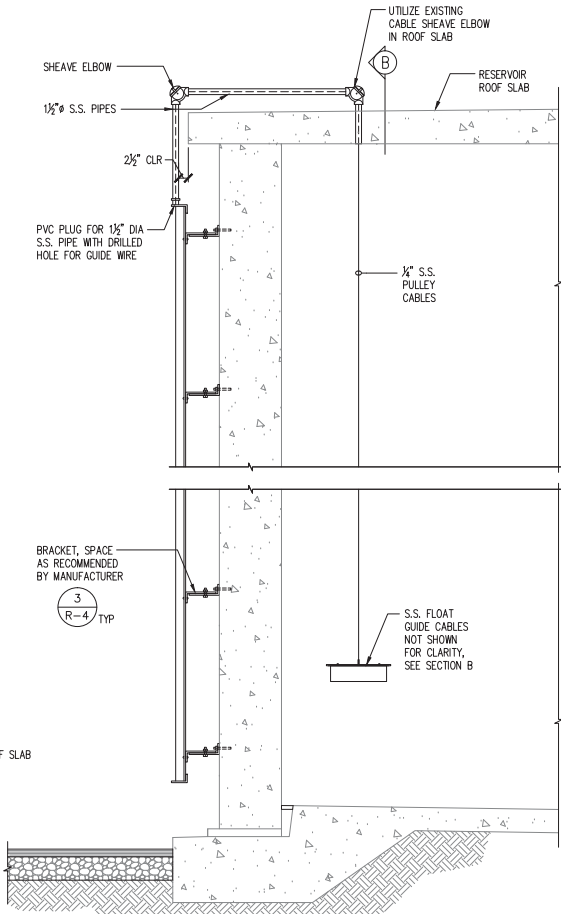
REVISION	DATE	DESCRIPTION	BY	APPROVED
<b>REHABILITATE PAUA VALLEY TANK #1</b>				
<b>RESERVOIR REPAIR DETAILS</b>				
APPROVED:				
COUNTY ENGINEER:		DEPT. PUBLIC WORKS, COUNTY OF KAUAI		DATE
APPROVED:				
MANAGER IN CHIEF ENGINEER:		DEPT. OF WATER, COUNTY OF KAUAI		DATE
This work was prepared by me or under my supervision and construction to this project will be under my observation				
Expiration Date of License 04-30-20				
KAI HAWAII, INC. HONOLULU, OAHU, HAWAII, 96813				
DRAWING NO. <b>R-3</b>		DESIGNED BY: DY		DRAWN BY: CAD
		DATE: 8-21-18		SHEET 6 OF 8 SHEETS

P:\4301-050\4301 DWS - Rehabilitate Paua Valley Tank #1, 0.5 MG Concrete, Kakaia\04 - Drawings\Structural\AutoCAD - Form\112018-13-13 13 PM.dwg, 9/2/2018 1:34:33 PM, dykcombs

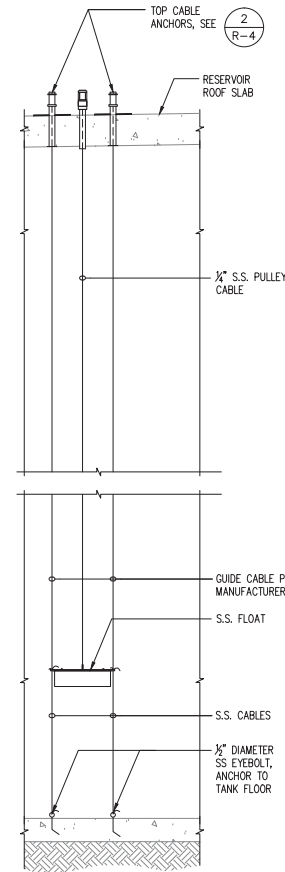
PROVIDE VAREC 6700 LEVEL INDICATOR FOR BULK STORAGE SYSTEM OR APPROVED EQUAL



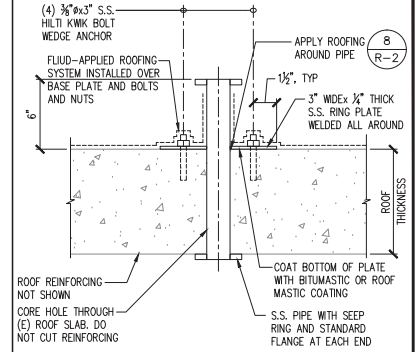
EXTERIOR ELEVATION



A SECTION

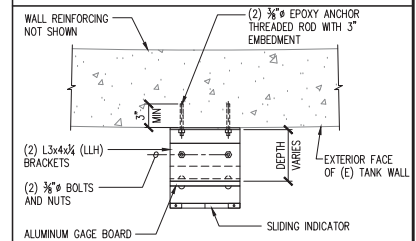


B SECTION



TYPICAL CABLE PIPE THROUGH ROOF

2 R-4 NOT TO SCALE



NOTES:  
1. FOR SIZE OF INDICATOR BOARD AND BRACKET REQUIREMENTS, SEE MANUFACTURER'S LITERATURE.  
2. BRACKETS, ANCHORS, NUTS AND BOLTS SHALL BE STAINLESS STEEL, TYPICAL.  
3. ALL ANCHOR BOLTS SHALL BE LOCATED TO AVOID EMBEDDED REINFORCING STEEL.

INDICATOR BRACKET PLAN DETAIL

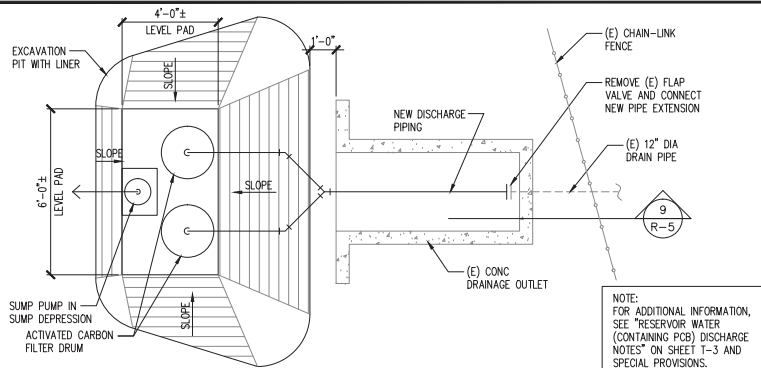
3 R-4 SCALE: 1 1/2" = 1'-0"

1 R-4 WATER LEVEL INDICATOR NOT TO SCALE

REVISION	DATE	DESCRIPTION	BY	APPROVED
<b>REHABILITATE PAUA VALLEY TANK #1</b>				
LEVEL INDICATOR DETAILS				
			APPROVED:	DATE
			COUNTY ENGINEER DEPT. PUBLIC WORKS, COUNTY OF KAUAI	
			APPROVED:	DATE
			MANAGER IN CHIEF ENGINEER DEPT. OF WATER, COUNTY OF KAUAI	
<p>This work was prepared by me or under my supervision and construction to this project will be under my observation.</p> <p>Expiration Date of License 04-30-20</p>				
<p>KAI HAWAII, INC. HONOLULU, OAHU, HAWAII, 96813</p>			<p>SHEET 7 OF 8 SHEETS</p>	
<p>DESIGNED BY: DY</p>		<p>DRAWN BY: CAD</p>		<p>DATE: 8-21-18</p>

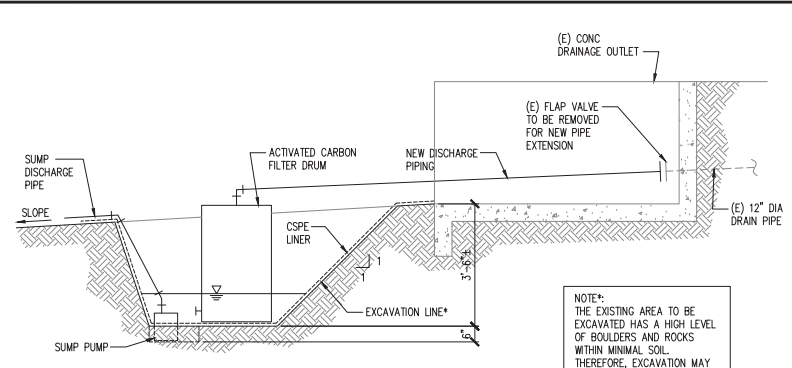
P:\4301-05\04339 DWS - Rehabilitate Puaa Valley Tank #1, 0.5 MG Concrete, Kakaia\004\_Drawing\Structural\AutoCAD\Comm\1208-08-09\_4339 DWS\_Paua\4339.dwg, 9/27/2018 1:34:14 PM, dykcoms





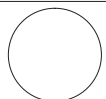
**1 RESERVOIR WATER DISCHARGE SCHEMATIC PLAN**  
 R-5 NOT TO SCALE

NOTE:  
 FOR ADDITIONAL INFORMATION,  
 SEE "RESERVOIR WATER  
 (CONTAINING PCB) DISCHARGE  
 NOTES" ON SHEET T-3 AND  
 SPECIAL PROVISIONS.



**2 SCHEMATIC SECTION**  
 R-5 NOT TO SCALE

NOTE\*:  
 THE EXISTING AREA TO BE  
 EXCAVATED HAS A HIGH LEVEL  
 OF BOULDERS AND ROCKS  
 WITHIN MINIMAL SOIL.  
 THEREFORE, EXCAVATION MAY  
 BE DIFFICULT WITH HAND TOOLS  
 ONLY.

REVISION	DATE	DESCRIPTION	BY	APPROVED
<b>REHABILITATE PAUA VALLEY TANK #1</b>				
<b>RESERVOIR WATER DISCHARGE SCHEMATIC PLAN AND SECTION</b>				
		APPROVED:		
		COUNTY ENGINEER DEPT. PUBLIC WORKS, COUNTY OF KAUAI	DATE	
This work was prepared by me or under my supervision and construction to this project will be under my observation.		APPROVED:		
		REGISTERED CHIEF ENGINEER DEPT. OF WATER, COUNTY OF KAUAI	DATE	
Expiration Date of License: 04-30-20				
<b>KAI HAWAII, INC.</b> HONOLULU, OAHU, HAWAII, 96813				
DRAWING NO. <b>R-5</b>		DESIGNED BY: DY		DRAWN BY: CAD
		DATE: 8-21-18		SHEET 8 OF 8 SHEETS

P:\4301-0350\4301 DWS - Rehabilitate Paua Valley Tank #1, 0.5 MG Concrete, Kelahele\004\_Drawing\Structural\AutoCAD\Formal\2018-08-09\_4301 DWS\_Pawa\4301-0350.dwg, 9/27/2018 1:35:33 PM, gyskomsa

***Attachment F –Disinfection Procedure***

DIVISION 300 – CONSTRUCTION

3. *For Hawaii, Kauai and Oahu only:*

- a. After hosing down the interior walls of the reservoir with chlorinated water with at least 50 mg/1 concentration, the floor shall be scrubbed and hosed with the wash water being flushed through the washout. The washout valve shall be closed, and the line filled with water as evidenced by its appearance at the floor level. The valve shall then be opened, and the washout drained to rid the line of any remaining debris. The Contractor shall utilize a pump with adequate pressure and velocity capacity for the hosing work. The discharge of all waters shall comply with all NPDES requirements.
- b. The leakage test for the reservoir shall consist of filling the reservoir at 5 feet height increments up to its overflow level and observing for any visible leaks on the exterior surfaces after each increment and at the end of seven (7) days. Should any leaks, sweat, or other evidence of moisture be present, the Contractor shall drain the reservoir to no lower than the inner perimeter water seal and shall take immediate action to seal the leak using appropriate methods acceptable to the Department. After the leaks are sealed, the leakage test shall be re-conducted for another seven (7) days. This procedure shall be repeated until the 7-day leakage test is successfully passed.
- c. Should the reservoir successfully pass the 7-day leakage test, 5% hypochlorite solution shall be added at a rate of 5 gallons per one million gallons of water. The water will then be ready for potable use.
- d. **Sampling.** In order to confirm that the water in the reservoir is acceptable for potable use, the Contractor shall collect two (2) water samples from the reservoir. The first sample shall be taken after the 7-day leakage test is completed and 12.5% hypochlorite solution, at a rate of 2 gallons per one million gallons of water, is added to the water in the reservoir. The second sample shall be taken 20 to 28 hours later. *(For Oahu only: The Contractor shall collect one (1) sample for each five feet of water added to the reservoir up to the overflow level. Water shall be held for 24 hours to allow time to confirm the microbiological quality of the water prior to adding the next 5 feet increment of water. At the end of the 7-day leakage test, a final sample shall be collected.)*

Sampling shall be done by the Contractor under the coordination of the inspector assigned to the project. Sampling bottles shall be furnished by a certified laboratory. Under no circumstances shall the sample bottles be rinsed out.

- e. **Certification.** The water samples shall be analyzed by a laboratory certified by the State Department of Health. The laboratory shall be certified to test for coliforms in potable drinking water.

## DIVISION 300 – CONSTRUCTION

The reservoir disinfection procedure shall be considered acceptable after the laboratory test results show the following for each water sample collected:

1. Total coliform counts equal to zero (0); and
2. Total bacterial count is less than 200 colonies per 100 mils.

If any water sample fails to meet the criteria noted above, the disinfection of the reservoir shall be repeated as directed by the Manager. After the reservoir is re-disinfected, new water samples shall be collected.

All costs associated with the microbiological testing shall be at the Contractor's expense.

- ~~4. *For Maui Only: After completion and acceptance of all leakage testing, disinfection procedure shall be as specified in AWWA C652 - "Standards For Disinfection Of Water-Storage Facilities". The discharge of all waters shall comply with all NPDES requirements.*~~
5. If repairs are done to the interior of the reservoir due to any leaks found during the 7-day leakage test, repeat from step "1" as required by the Manager. All materials used for the repairs done to the interior of the reservoir shall be in compliance with NSF 61. All items of work required due to the presence of leaks, sweat, or evidence of moisture on the exterior surfaces shall be at the Contractor's expense.
6. Re-sample and re-chlorinate as necessary and as directed by the Manager.

Although the reservoir is found to be water tight in the first leakage test, the Manager, if deems necessary, may require another leakage test before final acceptance of the reservoir.

**C. Payment.** Unless otherwise specified, no separate payment for the RESERVOIR LEAKAGE TEST AND DISINFECTION will be made; the compensation for such work shall be deemed to be included in the Lump Sum Bid for reservoir and appurtenances. The payment shall represent full compensation for furnishing all materials and for all labor, tools, equipment and incidentals, including but not limited to all water costs for the reservoir leakage test and disinfection, required for the work.

### 303.11 STRUCTURE CLEAN-UP.

**A. Description.** At the completion of the work, the Contractor shall remove all surplus materials, rubbish and debris of every kind from the project site.

The reservoir shall be scrubbed clean and placed in a neat condition prior to the water leakage test.

***Attachment G – Risk Based PCB Clean up Approval Application (Work Plan) dated 18 September 2018***



Ken Hayashida, P.E. | *President*  
Michael Hunnemann, P.E. | *Vice President*

September 18, 2018

Ms. Sara Ziff, P.E.  
Project Manager  
Corrective Action Section  
U.S. Environmental Protection Agency, Region 9  
75 Hawthorne Street (LND-4-1)  
San Francisco, California 94105

**Subject: TSCA Risk-Based PCB Cleanup Approval Application  
Department of Water, Rehabilitate Paua Valley Tank #1  
Kekaha, Kauai, Hawaii**

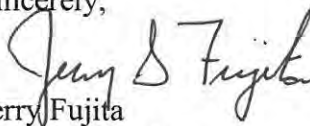
Dear Ms. Ziff:

KAI Hawaii, Inc. is pleased to submit the enclosed Risk-Based PCB Cleanup Approval Application for the Rehabilitation of the Paua Valley Tank #1. The Risk-Based PCB Cleanup Approval Application is submitted in accordance with the requirements of the Toxic Substances Control Act (TSCA, 40 CFR 761.61(c)) in order to obtain approval of the methods as described herein, to be used to discharge the PCB-containing storage water from the existing reservoir and to dispose of PCB waste.

The Risk-Based PCB Cleanup Approval Application includes information on the source, nature and extent of impact of the PCB-containing storage water and plans for removing and disposing of the PCB wastes. It also covers mitigation measures and a PCB monitoring plan to ensure that further PCB contamination is no longer a risk of injury to public health or to the environment.

Should you have any questions or require additional information, please contact me at (808) 791-3969 (direct office) or by email ([jfujita@kaihawaii.com](mailto:jfujita@kaihawaii.com)).

Sincerely,

  
Jerry Fujita  
KAI Hawaii, Inc.

# **RISK-BASED PCB CLEANUP APPROVAL APPLICATION**

## **For Rehabilitate Paua Valley Tank #1, 0.5 MG Concrete Kekaha, Kauai, Hawaii**



Prepared for:

United States Environmental Protection Agency  
Region 9  
Corrective Action Section

September 18, 2018

Prepared by:



50 South Beretania Street, Suite C-119C  
Honolulu, HI 96813

## **I. Introduction**

This Risk-Based PCB Cleanup Approval Application has been prepared for the County of Kauai Department of Water, Rehabilitation of the Paua Valley Tank #1. The Paua Valley Tank #1, 0.5 MG concrete reservoir is located in the State of Hawaii, in the Kekaha area on the island of Kauai (TMK (4) 1-2-002:039), and is accessed by a gated unpaved access road from Kokee Road. The reservoir site land is owned by the State of Hawaii with an Executive Order to the County of Kauai, Department of Water for well and water tank purposes. We estimate the reservoir was constructed in 1974 based on the signature dates on the original construction drawings, resulting in the estimated age of the reservoir being 43 years.

The reservoir has a nominal capacity of 500,000 gallons (0.5 MG) with an inside diameter of 69 feet and a maximum water height of 18 feet to the overflow pipe opening. The reservoir is cast-in-place conventionally reinforced concrete construction. The walls have a constant thickness for their full 20-foot height. The flat concrete roof slab is supported on the interior by four (4) square concrete columns. There is an exterior roof-access ladder with a fall protection system and a security shield at the bottom of the ladder to discourage unauthorized use.

The rehabilitation project proposed by the County of Kauai, Department of Water, will involve the repair of the concrete reservoir which includes interior and exterior work. The main concern prompting the request for rehabilitation of the reservoir was a water leak at the reservoir wall base. During the initial assessment of the condition of the reservoir, the water in the reservoir was drained and suspected hazardous material samples were collected from the interior and exterior of the reservoir. Samples of the coal tar lining at the interior floor and walls, and wall base joint sealant was taken and tested, and the results turned out positive for Polychlorinated Biphenyl (PCB). Subsequent to the initial assessment and after the reservoir had been refilled, an oily layer was found floating on the surface of the water. Samples of the oily layer was taken and also had been tested positive for PCB.

## **II. Purpose and Scope**

The purpose of this Risk-Based PCB Cleanup Approval Application (Application) is to request an approval of the methods as described herein, to be used to discharge the PCB-containing storage water from the existing reservoir and to dispose of PCB waste in a manner other than prescribed in 40 CFR 761.61(a) or (b), and to determine that these methods will not pose an unreasonable risk of injury to public health or the environment. This application includes information on the source, nature and extent of impact of the PCB-containing storage water and plans for removing and disposing of the PCB wastes.

As required by 40 CFR 761.61(a)(3)(e), copies of the certifications from the property owner, County of Kauai Department of Water, and responsible party conducting response actions, County of Kauai Department of Water, are provided in Appendix A.



### III. Relevant Contacts

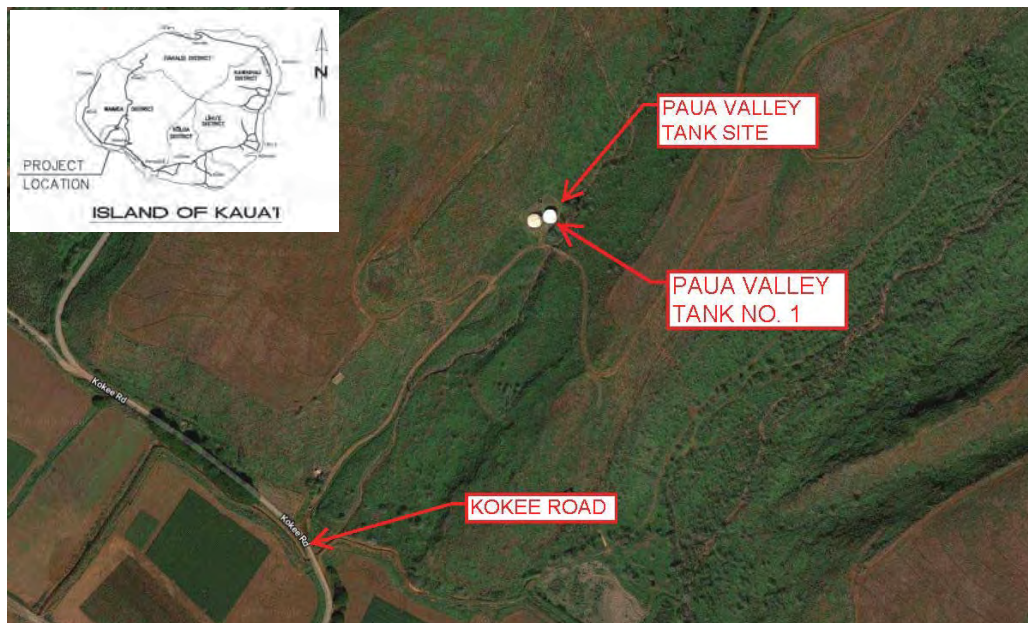
Owner: County of Kauai Department of Water  
Eric Fujikawa, Project Engineer  
4398 Pua Loke Street  
Lihue, Hawaii 96766  
Phone: (808) 245-5412

Consultants: KAI Hawaii, Inc.  
Jerry Fujita, Structural Engineer  
50 S. Beretania Street #C-119C  
Honolulu, Hawaii 96813  
Phone: (808) 791-3969

Myounghee Noh & Associates  
Myounghee Noh, Environmental Consultant  
99-1046 Iwaena Street, Suite 210A  
Aiea, Hawaii 96701  
Phone: (808) 484-9214

### IV. Site Description

The reservoir site is located on the Southwest side of the island of Kauai, in the slopes above the town of Kekaha. The site is occupied by two water reservoirs and a pump control building, and is enclosed by a site perimeter chain-link fence. The area outside of the site is open terrain, covered with vegetation. See Figure 1. This water system served about 5,800 people residing in the towns of Kekaha and Waimea (ehawaii.gov, 2017).



**Figure 1: Site Location Plan**

## Climate

Kekaha has a tropical climate. The site is located on the dry side of Kauai and receives 33 inches of rain annually (Mink & Lau, 1992). The average temperature is 75°F, with August being the hottest month averaging 78°F and January being the coolest month with an average of 72°F (Climate-Data, 2017).

## Soils/Geology

Kauai is the fourth largest and the oldest of the main Hawaiian Islands. It was formed from a single shield volcano that has been highly weathered and eroded to the point that the summit peak can be difficult to locate.

The age of Kauai has transformed much of its surface lava flows into weathered soils lending the island more erosional landforms versus the volcanic landforms found on the younger Hawaiian Islands (Morgan, 1996).

Mink and Lau (1992) describe the geology in the area as the following:

The region is a part of the southwest flank of the original volcano. Napali lavas terminate as a fossil sea cliff along a mile wide coastal plain of terrestrial and marine sediments. The Mana Plain is the most extensive and thickest accumulation of sediments in the island. Inland a few dikes have been mapped.

The United States Department of Agriculture Natural Resources Conservation Service classifies the soil at the tank site as Kekaha extremely stony silty clay loam with 0 to 35 percent slopes. Typically, this soil type is composed of extremely stony silty clay from 0 to 21 inches and clay from 21 to 70 inches. It is well-drained and more than 80 inches from the water table. Soil to the west of the drainage ditch are classified as Waiawa extremely rocky clay with 30 to 80 percent slopes. This soil type is typically composed of clay from 0 to 14 inches, and bedrock from 14 to 24 inches. It is well drained and is generally 6 to 15 inches to lithic bedrock (United States Department of Agriculture, 2008).

## Surface Water

Mink and Lau (1992), describe the hydrogeology in the area as the following:

Having an average rainfall of just 33 inches, Kekaha is the driest Aquifer System in Kauai. Surface drainage is by way of small, non-perennial streams that debouch onto the Mana Plain. The Plain originally was a vast swamp but is not artificially drained to allow cropping.

The tank is located adjacent to a dry streambed and provides the drainage ditch for the tank. During previous site visits, there were no indications of water flow in the stream. The stream likely flows during times with heavy rainfall.

## Groundwater

The HDOH Safe Drinking Water Branch established an Underground Injection Control (UIC) line to serve as a boundary between drinking water and non-drinking water portions of aquifers. Areas above (mountain side) the UIC line are within drinking water portions of the aquifer, while areas below (ocean side) the UIC line are in non-drinking water portions of the underlying aquifer. The subject property is above the UIC line in a drinking water portion of the aquifer (Hawaii Department of Health Safe Drinking Water Branch, 2014).

The hydraulic gradient, and therefore the expected direction of travel, of the basal groundwater within the basaltic formation is, in general, from mountain areas to the shoreline. According to Mink and Lau (1992), the tank site is located above the Kekaha Aquifer System of the Waimea aquifer sector and described the groundwater at the aquifer as follows:

High-level dike aquifers may occur in Napali lavas in the interior near the Waimea Canyon divide. Otherwise the flank lavas contain basal groundwater. The Napalia aquifer beneath the Mana Plain cap rock is artesian. This aquifer has been developed as a source of irrigation supply. The sediments are saturated with brackish to salty water. Upward leakage into the sediments from the Napali artesian aquifer is the cause of the original swamp conditions. When artificial drainage for the Plain ceases, it will again become a swamp. Potable water is developed from the wells near Kekaha and Waimea. These wells are located at the inland edge of the Plain.

## Current/Future Land Use

The current land use of the site is for water storage tanks that previously serviced the Kekaha and Waimea areas. The future land use will remain the same; no future development at the site is expected.

## **V. Pre-Cleanup Site Characterization**

During the initial assessment of the condition of the reservoir, the water in the reservoir was drained and suspected hazardous material samples were collected from the interior and exterior of the reservoir. Samples of the coal tar lining at the interior floor and walls, and wall base joint sealant was taken and tested for PCB, and had results up to 283 ppm. See the Hazardous Material Survey Report in Appendix B.

After the reservoir was refilled, an oily layer floating at the top of the water surface was noticed. The oily layer was sampled for PCB and the result was 13 µg/L (ppb). The water in the tank was also sampled at the entry point to the water system, and the result was not detected (i.e., less than or equal to the method detection limit of 0.1 ppb).

It is currently known that the extent of the PCB contamination is within the concrete reservoir and within the Paua drainage ditch outside of the subject property, see Figure 2. PCB mitigation for contaminated soils within the Paua drainage ditch is outside the scope of this Application. The reservoir is currently off-line.

## VI. PCB Cleanup Plan

### BACKGROUND:

Currently the reservoir contains approximately 0.35 MG of water with detected PCB concentrations at 0.013 mg/L (13  $\mu\text{g/L}$ ) on the water surface in excess of the 0.0005 mg/L (0.5  $\mu\text{g/L}$ ) allowable limit for potable water. The water from the effluent line drawn from the bottom of the reservoir does not have any detected PCB concentration.

### DISCHARGE LOCATION AND SCHEDULE:

1. The water in the reservoir will be discharged into the Paua drainage ditch, see Figure 2, at a rate to allow the discharged water to infiltrate into the ground surface before reaching approximately 200 feet downstream of the reservoir discharge pipe. It is expected that the discharge rate will be about 14,000 gallons/day for 25 days. See photos below for areas to receive the discharged reservoir water.



**Figure 2: Enlarged Site Location Plan**



**Photo 1: Reservoir discharge outlet**



**Photo 2: Paua Drainage Ditch**



**Photo 3: Paua Drainage Ditch**

## DISCHARGE PROCEDURE AND SAMPLING PLAN:

1. Test water at effluent line sampling tap which draws water from the bottom region of the reservoir water to confirm the PCB-concentration is within allowable limit to allow water to be discharged without any filtration. Consult with USEPA and HDOH about PCB concentration and obtain approval to discharge. EPA Method 505 will be used for water testing. The required sample container per sample is two (2) one-liter glass amber bottle. Recommend collecting two samples for field quality control.
2. If the PCB concentration in water from Step 1 is below allowable upper limit (0.5 µg/L), SLOWLY discharge water from the reservoir cleanout drain line to minimize the mixing of the water with the PCB-containing “scum” layer on the water surface. Drain continuously at a slow rate until the water level reaches a depth of approximately 2 feet.
3. Connect piping at end of drainage discharge pipe from reservoir by removing flap gate valve and connect two liquid phase absorber unit drums containing virgin activated carbon 8 x 12 mesh design to absorb PCB. The discharge rate for two units connected in parallel is 10 gallons per minute. This absorber unit drum is a manufactured assembly and can be purchased from the manufacturers listed below. Release as much water as will drain by gravity. The remaining residue will be left for the project contractor to clean up as part of the interior coating removal work.

Activated Carbon Filter Drum: A liquid phase activated carbon adsorption system for environmental remediation and institutional water conditioning applications. Contained in a steel drum is 150-200 pounds of virgin activated carbon capable of handling a flow of at least 10 gpm, with a maximum operating pressure of 6 psi. This manufactured assembly can be purchased from the following manufacturers:

- a. “Econosorb-LS”, by TIGG Corporation, 1 Willow Avenue, Oakdale, PA, Phone: (724) 703-3020, [www.tigg.com](http://www.tigg.com).
  - b. “Water Purification Canister L-1”, by Carbtrol Corporation, 955 Connecticut Ave., Suite 5202, Bridgeport, CT 06607, Phone: (800) 242-1150, [www.carbtrol.com](http://www.carbtrol.com).
4. Take a follow-up effluent water sample, discharged from the activated carbon filter units to confirm the PCB-concentration is below the allowable limit, 0.5 µg/L, and analyze using EPA Method 505. The required sample container per sample is 2 x 1L glass amber. If the PCB result is greater than 0.5 µg/L, the Contractor shall stop discharging water and replace granular activated carbon or add an additional treatment such as bag filters with 0.5 µm after carbon filtration. Repeat this step until the PCB concentration is below the allowable limit.
  5. Perform Toxicity Characteristic Leaching Procedure (TCLP) analysis, Method 1311, on the activated carbon filter drum units to determine if the waste is hazardous or

non-hazardous. If PCB concentration is determined to be less than 50 ppm, the activated carbon filter drum units can be disposed of at the municipal landfill with no special requirements after all the water has been filtered.

6. If the PCB concentration is determined to be greater than 50 ppm, dispose of the activated carbon filter drum units as permitted by State, and Federal law based on the PCB concentration of the surface filter material, absorbent and carbon filter testing.
7. EPA will issue an approval document per TSCA requirements for the disposal of the oil-soaked absorbent pad based on the requested test results obtained along the process.

#### SAMPLE COLLECTION AND LABORATORY ANALYSIS:

Collected samples shall be stored between 0 - 4 °Celsius until the samples are delivered to the laboratory. The samples shall be stored at the required temperature immediately after collection to preserve the condition at the time of collection. The sampler shall coordinate further with an analytical laboratory to confirm the testing method, sample amount, and sample preservation requirements.

### **VII. Mitigation and Monitoring Plan after Reservoir Repair**

Following the water discharge and disposal activities, the rehabilitation of the existing reservoir will continue with the removal of the existing interior coating and installation of a new interior coating system of the floor, pipe exterior, wall, and column surfaces. The interior coating system will be NSF 61 certified and be installed following quality control procedures with applicable ASTM, NACE, and SSPC standards and the protective coating manufacturer's recommendation. The new coating system will cover all existing surfaces that was once in contact with PCB.

After the interior recoating and refilling of the reservoir with water, and prior to placing the reservoir back in service, the Department of Water will sample and test the water at the discharge point to the distribution system for PCB. Following confirmation that PCB is undetectable, the reservoir shall be placed back in service. The Department of Water will sample and test the water using EPA Method 505 on a quarterly basis for three (3) quarters. If PCB is still at non-detectable levels for that period of time, sampling will continue on an annual basis. Sampling and testing operations may cease upon confirmation that PCB concentrations are at non-detectable levels for the next three (3) consecutive years.

# APPENDIX A

## Certifications



**Responsible Party Certification**

Risk-Based PCB Cleanup Approval Application  
County of Kauai Department of Water  
Lihue, Hawaii

As the party responsible for conducting the proposed cleanup described in the Risk-Based PCB Cleanup Approval Application, County of Kauai Department of Water certifies that all sample collection procedures, laboratory analysis, and discharging procedures used to characterize the PCB contamination at the Site are on file at the following location for EPA inspection:

County of Kauai Department of Water  
4398 Pua Loke Street  
Lihue, Hawaii 96766

To access these files, contact Bryan Wienand at (808) 245-5408, to schedule an appointment and identify specific records to be inspected. The Department of Water will compile the information requested and make the information available for review in our office or transmit copies directly to the EPA representative requesting the information.

  
\_\_\_\_\_  
Bryan Wienand  
Manager and Chief Engineer  
County of Kauai Department of Water

9/13/18  
\_\_\_\_\_  
Date

**Property Owner Certification**

Risk-Based PCB Cleanup Approval Application  
County of Kauai Department of Water  
Lihue, Hawaii

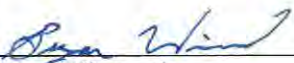
The Risk-Based PCB Cleanup Approval Application describes response actions that will be conducted on the following property:

County of Kauai Department of Water  
Pua Valley Tank Site  
Kekaha, Hawaii 96752  
TMK: (4) 1-2-002:039

As the owner of the property where remedial actions will be conducted described in the Risk-Based PCB Cleanup Approval Application certifies that all sample collection procedures, laboratory analysis, and discharging procedures used to characterize the PCB contamination at the Site are on file at the following location for EPA inspection:

County of Kauai Department of Water  
4398 Pua Loke Street  
Lihue, Hawaii 96766

To access these files, contact Bryan Wienand at (808) 245-5408, to schedule an appointment and identify specific records to be inspected. The Department of Water will compile the information requested and make the information available for review in our office or transmit copies directly to the EPA representative requesting the information.

  
\_\_\_\_\_  
Bryan Wienand  
Manager and Chief Engineer  
County of Kauai Department of Water

9/13/18  
\_\_\_\_\_  
Date

APPENDIX B  
Hazardous Material Survey Report

---

**HAZARDOUS MATERIAL SURVEY REPORT  
FOR  
REPAIRS TO KEKAHA 0.5 MG CONCRETE STORAGE TANK  
COUNTY OF KAUAI DEPARTMENT OF WATER  
KEKAHA WATER SYSTEM  
KEKAHA, ISLAND OF KAUAI 96752**

**TMK (4) 1-2-002:039**

**MNA PROJECT 2388\_3**

**DECEMBER 14, 2017**



**Myounghee Noh & Associates**

**Environmental Studies and Consulting Services**

200 Kohola Street, Hilo, Hawaii, USA 96720 • 808.935.8727  
99-1046 Iwaena Street, Suite 210A, Aiea, Hawaii, USA 96701 • 808.484.9214

---

This report is prepared for:

KAI Hawaii, Inc.  
50 S. Beretania Street, #C-119C  
Honolulu, Hawaii 96813

**HAZARDOUS MATERIAL SURVEY REPORT**  
**FOR**  
**REPAIRS TO KEKAHA 0.5 MG CONCRETE STORAGE TANK**  
**COUNTY OF KAUAI DEPARTMENT OF WATER**  
**KEKAHA WATER SYSTEM**  
**KEKAHA, ISLAND OF KAUAI 96752**

TMK (4) 1-2-002:039

MNA Project 2388\_3

December 14, 2017



Akari Ihara  
Building Inspector  
(HI Cert. HIASB-1014, Exp. 04/20/2018)



Jessica Walsh  
Report Writer



Myounghee Noh, CIH  
Principal

Myounghee Noh & Associates, L.L.C.  
Environmental Studies and Consulting Services  
99-1046 Iwaena Street, Suite 210A, Aiea, HI 96701  
Tel (808) 484-9214  
[www.noh-associates.com](http://www.noh-associates.com)

**TABLE OF CONTENTS**

**EXECUTIVE SUMMARY.....iv**

**1.0 INTRODUCTION..... 1**

**2.0 SAMPLING AND SURVEY METHODS ..... 1**

    2.1 Identifying Homogeneous Materials..... 3

    2.2 Building Material Sampling ..... 3

**3.0 LABORATORY INFORMATION ..... 4**

**4.0 ASBESTOS RESULTS..... 4**

**5.0 LEAD RESULTS..... 6**

**6.0 ARSENIC RESULTS ..... 7**

**7.0 SUSPECT PCB-CONTAINING BULK MATERIAL RESULTS ..... 7**

**8.0 SUMMARY OF SURVEY RESULTS ..... 8**

**9.0 RECOMMENDATIONS FOR RENOVATION AND CONSTRUCTION WORK ..... 9**

    9.1 Asbestos-Containing Materials ..... 9

    9.2 Lead-Containing Paints..... 11

    9.3 Arsenic-Containing Materials ..... 12

    9.4 PCB-Containing Bulk Materials ..... 12

**10.0 LIMITATIONS ..... 14**

**FIGURE**

Figure 1. Vicinity Map..... 2

**TABLES**

Table 1. Summary of Sampling and Results..... 3

Table 2. Asbestos-Containing Material Determination ..... 5

Table 3. Lead-Containing Paint Determination..... 6

Table 4. Bulk PCB Determination..... 7

## **APPENDICES**

- Appendix A Inspector Certifications
- Appendix B Homogeneous Materials Identified and Sample Types Collected
- Appendix C Sample and Hazardous Material Location Drawings
- Appendix D Photographs
- Appendix E Laboratory Analytical Reports

## **CONTRIBUTORS**

Project Manager	Akari Ihara
Certified Inspectors	Akari Ihara, Danny Falanug
Data QC	Kristin Cabanila
Drafter/Illustrator	Kristin Cabanila
Report Writer	Jessica Walsh
Editor/QC	Akari Ihara

## EXECUTIVE SUMMARY

In July 2017, Myounghee Noh & Associates, L.L.C. (MNA), was retained by KAI Hawaii, Inc., to conduct a hazardous material survey at the County of Kauai Department of Water (DOW) Paua Valley 0.5 MG concrete water tank located at Tax Map Key (TMK) (4) 1-2-002:039, Kekaha, Kauai. The survey targeted building materials in and on the 0.5 MG water tank; the second tank on the parcel was a metal water tank and was not included in the survey.

The objective of the survey was to identify the existence (if any), extent, and condition of hazardous materials present in and on the tank, so that the information can be incorporated in the rehabilitation design.

On August 17, 2017, MNA conducted this hazardous material survey and identified a total of 19 suspect building materials. On October 19, 2017, MNA collected additional bulk samples from the black coating on the interior wall of the tank for analysis of PCB and asbestos content, at the request of the State of Hawaii Department of Health Safe Drinking Water Branch. Based on the analysis of 21 asbestos bulk samples, 12 lead paint chip samples, and 12 polychlorinated biphenyls (PCB) bulk samples, MNA provides the following summary:

- No regulated asbestos-containing materials (ACM) were identified during the survey. One material, **beige coating** in poor condition **on concrete floor** contained 0.25% asbestos. This level of asbestos is considered a trace amount. While the less than 1% asbestos is not a regulated material, airborne fibers in unventilated space can be a respiratory hazard.
- Four lead-containing paints (LCP) were identified in the project area:
  - **Light blue paint** in fair condition, **710 milligrams per kilogram (mg/kg)** and **1,200 mg/kg, on exterior concrete roofing system**, approximately 2,000 square feet.
  - **Light green paint** in fair condition, **1,200 mg/kg** and **1,400 mg/kg, on exterior metal handrail and ladder**, approximately 20 linear feet.

Two of the identified LCP were lead-based paint (LBP), exceeding 5,000 mg/kg, as follows:

- **Dark green paint** in fair condition, **41,000 mg/kg** and **55,000 mg/kg, on exterior metal hatch**, approximately 5 square feet.
- **Beige paint** in poor condition, **40,000 mg/kg** and **41,000 mg/kg, on interior concrete floor**, approximately 5,000 square feet.
- No suspect arsenic-containing materials were identified in the project area.
- Three PCB-containing materials were identified in the concrete water tank:
  - **Beige coating** in poor condition, **28.4 mg/kg (total PCB congeners), on interior concrete floor and debris**, approximately 5,000 square feet.
  - **Beige asphaltic base sealant** in fair condition, **10.5 mg/kg (total PCB congeners), on interior concrete joint**, approximately 220 square feet.



- **Black coating** in poor condition, **283 mg/kg (total PCB congeners) based on confirmation sampling, on interior concrete wall**, approximately 4,840 square feet.

No suspected hazardous materials were identified on the tank access road, which is slated for re-paving as part of this project.

Based on the visual survey and sampling and analysis of suspect bulk materials and paints, special hazard control measures are warranted for work involving lead-containing paint (LCP), lead-based paint (LBP), and PCB-containing material. These control measures are briefly described in Section 9 Recommendations for Renovation and Construction Work. General dust and runoff controls are also warranted.

The contractor must verify the location and volumes of potentially hazardous materials and determine the appropriate dust and hazard control measures based on the area and material to be disturbed. Quantities of materials provided in this report are based on visual approximations only during the survey and should not be used for bidding purposes.

## 1.0 INTRODUCTION

Myounghee Noh & Associates, L.L.C. (MNA), under an agreement with KAI Hawaii, Inc., conducted a hazardous material survey for the County of Kauai Department of Water (DOW) Paua Valley 0.5 MG Tank located at Tax Map Key (TMK) (4) 1-2-002:039, Kekaha, Kauai.

MNA's survey was conducted in support of the planned concrete water tank repair and rehabilitation project. The building materials on the DOW 0.5MG Tank were assessed; the second tank on the parcel was a metal tank and was not part of the survey. The survey targeted the following materials:

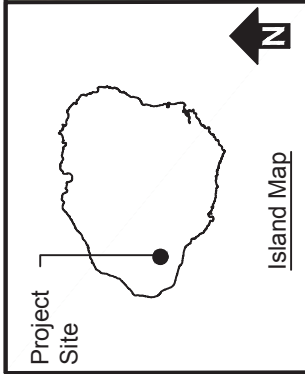
- Hazardous building materials due to the suspected presence of asbestos, lead, or arsenic.
- Suspect polychlorinated biphenyls (PCB)-containing tank liner material.



Kauai County DOW 0.5MG Tank  
August 2017

## 2.0 SAMPLING AND SURVEY METHODS

During August 17 and October 19, 2017, State of Hawaii-certified building inspectors, Akari Ihara and Danny Falanug, conducted the hazardous material survey. The inspectors performed a visual assessment of the interior and exterior of the tank, identified materials suspected of containing asbestos, lead, arsenic, or PCB, and collected samples of these materials. Inspector certifications are presented in Appendix A.



Kekaha 0.5  
MG Tank

Old Mana Rd.

Kokee Rd.

Kekaha Rd.

Hukipo Rd.

Scale  
600 feet

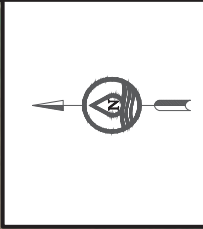


Figure 1. Vicinity Map  
Kekaha Water System  
0.5 MG Concrete Storage Tank  
Kekaha, Island of Kauai

## 2.1 Identifying Homogeneous Materials

The inspectors identified building materials with the same appearance, color, and substrate as homogeneous materials. Interior homogeneous materials are considered unique per building and building floor, while exterior building materials are considered unique per building. Building materials with the same characteristics (appearance, color, and substrate), as an identified homogeneous material, should be considered to possess the same hazard characteristics, unless specifically identified as otherwise in the report. As an example, if dark green paint on metal is found to be lead-based paint (LBP), then all identical dark green paint on metal in the survey area should be treated as LBP. Table 1 provides an overview of sampling and a summary of hazardous materials identified.

**Table 1. Summary of Sampling and Results**

Materials Sampled	Samples Submitted/Inspected	Suspect Material Locations	Identified Hazardous Materials
<b>Paua Valley 0.5 MG Concrete Water Tank</b>			
Asbestos in bulk material or paint	21	Floor, roofing system, sealant joint, vent, walls	1 Material containing trace asbestos*
Lead in paint	10	Floor, handrail, hatch, ladder, roofing system, walls	4 LCP (710 mg/kg – 55,000 mg/kg) including 2 LBP (40,000 mg/kg – 55,000 mg/kg)
Arsenic in bulk material	0	--	None
PCB in bulk material	12	Debris, floor, sealant joint, walls	3 PCB-containing tank liner materials (10.5 mg/kg – 283 mg/kg Total PCB)

\* Trace indicates that one or more asbestos fibers were detected by the point count method. While the less than 1% asbestos is not a regulated material, OSHA considers the trace amount as a health concern.

LBP – Lead-Based Paint,  $\geq 5,000$  mg/kg

mg/kg – milligrams per kilogram (equivalent to parts per million)

LCP – Lead-Containing Paint,  $< 5,000$  mg/kg

PCB – Polychlorinated biphenyls

## 2.2 Building Material Sampling

Bulk and paint samples were collected using a decontaminated chisel, razor, or hammer in a manner that minimized airborne dust. The inspector collected triplicate samples for asbestos and PCB-containing tank liner material and duplicate samples for lead. Additional confirmation sampling was conducted for the tank liner material. No suspected arsenic-containing building materials were identified. Samples were placed in sealable plastic bags, labeled with a unique identification number, and recorded on a chain-of-custody. For each sample, the date, sample appearance, analyte, and sample location were recorded on a field data form. Asbestos and PCB samples were transported under chain-of-custody to LA Testing in South Pasadena, California.

LA Testing utilized its sister company EMSL Analytical, Inc., in Cinnaminson, New Jersey, to analyze the PCB samples. Lead samples were transported under chain-of-custody to Hawaii Analytical Laboratory, LLC, in Honolulu, Hawaii.

### **3.0 LABORATORY INFORMATION**

LA Testing analyzed the asbestos samples by polarized light microscopy using the Environmental Protection Agency (EPA) Method 600/R-93/116. LA Testing, South Pasadena, is certified by:

- National Voluntary Laboratory Accreditation Program (NVLAP), certification 200232-0
- State of Hawaii Department of Health (HDOH), certification L-01-034
- American Industrial Hygienist Association (AIHA) Environmental Lead Laboratory Accreditation Program (ELLAP), certification 102814

Hawaii Analytical Laboratory analyzed the lead samples by flame atomic absorption spectroscopy using the EPA Method 7082m. Hawaii Analytical Laboratory, Honolulu, is certified by:

- NVLAP, certification 200655-0
- HDOH, certification L-14-002
- AIHA ELLAP, certification 101812

EMSL Analytical analyzed the PCB samples by gas chromatography using the EPA Method 3540C/8082A. EMSL Analytical, Cinnaminson, is certified by the New Jersey Environmental Laboratory Accreditation Program (ELAP), certification 03036.

### **4.0 ASBESTOS RESULTS**

Materials determined to contain greater than, or equal to, 1% asbestos are considered regulated asbestos-containing material (ACM) under the National Emission Standards for Hazardous Air Pollutants (NESHAP) as specified in 40 Code of Federal Regulations (CFR) Part 61 Subpart M. The U.S. Occupational Safety and Health Administration (OSHA) Asbestos General Industry and Construction Standards also define ACM as 1% asbestos or more by volume under 29 CFR 1910.1001 and 29 CFR 1926.1101, respectively. However, any measurable levels of asbestos fibers are considered to be a health concern.

Six homogeneous materials suspected of containing asbestos were identified and sampled, generating 18 samples for analysis. However, none of the samples contained 1% or greater asbestos by volume. Therefore, it is concluded that no regulated ACM are present in the area anticipated to be disturbed (Table 2).

One material (HM 7, beige cement material on interior concrete floor) contained less than 1% asbestos, and was therefore subjected to a point count analysis. Laboratory point count analytical results for this material indicated trace amounts of asbestos, less than 0.25% asbestos, and is not classified as ACM. The term “trace” indicates that one or more asbestos fibers were detected by the point count method. While the less than 1% asbestos is not a regulated material, airborne fibers in unventilated space can be a respiratory hazard and health concern.

Due to the <1% results, an additional triplicate confirmation sample was collected for the black coating on the inner concrete wall (HM ID 9). It was verified that the coating material contained no measurable amount of asbestos, but there was insufficient volume of concrete in the sample to verify asbestos level in the concrete wall. This material should be sampled prior to disturbance.

The suspected ACM descriptions and identifiers are provided in Appendix B. Sample location drawings are provided in Appendix C. Photographs of suspected materials are presented in Appendix D. Laboratory analytical reports, chain-of-custody, and field data forms are provided in Appendix E.

**Table 2. Asbestos-Containing Material Determination**

Locations	HM ID	Material Color	Material	Substrate	Result	Condition	Estimated Quantity
Roofing system	2	Lt. blue	Paint/skim coat	Concrete	ND	Fair	3,850 sq. ft.
Roof vent	3	Gray	Cement board	Concrete	ND	Fair	105 ln. ft.
Exterior wall	11	Orange	Paint/skim coat	Concrete	ND	Poor	4,840 sq. ft.
Tank floor	7	Beige	Coating Cement material	Concrete	ND <0.25%*	Poor	3,850 sq. ft.
Tank interior Sealant joint	8	Beige	Coating Texture Tar	Concrete	ND	Fair	220 sq. ft.
Tank interior wall	9	Black	Coating	Concrete	ND	Poor	4,850 sq. ft.
Tank interior wall	9C1	Black	Coating	Concrete	ND	Poor	4,850 sq. ft.

\* Indicates presence of materials containing trace asbestos. “Trace” means that one or more asbestos fibers were detected by the point count method. While the less than 1% asbestos is not a regulated material, OSHA considers the trace amount as a health concern.

Fair – Material is functional for its installed purpose but shows initial signs of deterioration beyond the cosmetic.  
Poor – Material shows significant deterioration and may not be functional for its installed purpose. The binding of the material has decreased integrity as indicated by peeling, cracking, or crumbling of the material.

Abbreviations and Acronyms

HM ID – Homogeneous Material Identifier                      ND – Not Detected  
In. ft. – Linear Feet    sq. ft. – Square Feet

**5.0 LEAD RESULTS**

The U.S. Department of Housing and Urban Development (HUD) and the EPA define paint containing 5,000 milligrams per kilogram (mg/kg), or 0.5% by weight, or more of lead to be LBP. OSHA and the State of Hawaii consider paint containing any measurable concentration of lead to be lead-containing paint (LCP) and a health concern. When lead is detected in a multi-layer sample, it is assumed that all layers represented by the sample contain lead at the same concentration.

Five suspected lead paints were identified and sampled, generating 10 paint chip samples. Four LCP were identified in the survey area, with sample results ranging from 710 mg/kg to 55,000 mg/kg. Two of those LCP were identified as LBP, exceeding 5,000 mg/kg, the threshold for LBP (Table 3).

Suspected LCP descriptions and identifiers are provided in Appendix B. Sample and hazardous material location drawings are in Appendix C. Photographs of suspected LCP are presented in Appendix D. Laboratory analytical reports, chain-of-custody, and field data forms are provided in Appendix E.

**Table 3. Lead-Containing Paint Determination**

Locations	HM ID	Material Color	Material	Substrate	Result (mg/kg)	Condition	Estimated Quantity
Roofing system	1	Lt. blue	Paint	Concrete	LCP 710 - 1,200	Fair	3,850 sq. ft.
Roof hatch	4	Dk. green	Paint	Metal	<b>LBP 41,000 - 55,000</b>	Fair	10 sq. ft.
Exterior handrail, ladder	5	Lt. green	Paint	Metal	LCP 1,200 - 1,400	Fair	90 ln. ft.
Exterior wall	10	Orange	Paint	Concrete	<40	Poor	4,840 sq. ft.
Exterior wall	12	Beige	Paint	Concrete	<40	Poor	2,420 sq. ft.
Interior Floor	6	Beige	Coating	Concrete	<b>LBP 40,000 - 41,000</b>	Poor	3,850 sq. ft.

**Bold values indicate results above the reporting limit.**

Fair – Material is functional for its installed purpose but shows initial signs of deterioration beyond the cosmetic.

Poor – Material shows significant deterioration and may not be functional for its installed purpose. Paint is bubbling or peeling over 20% or more of surface area and no longer protects the substrate.

**Abbreviations and Acronyms**

HM ID – Hazardous Material Identifier  
LBP – Lead-Based Paint,  $\geq 5,000$  mg/kg  
LCP – Lead-Containing Paint,  $< 5,000$  mg/kg

ln. ft. – Linear Feet  
mg/kg– milligrams per kilogram or parts per million  
sq. ft. – Square Feet

**6.0 ARSENIC RESULTS**

The disturbance of arsenic-containing materials is regulated by the OSHA Inorganic Arsenic General Industry Standard under 29 CFR 1910.1018. No suspected arsenic-containing materials were observed; therefore, no samples were collected during this survey.

**7.0 SUSPECT PCB-CONTAINING BULK MATERIAL RESULTS**

The storage and disposal of PCB-containing materials is regulated by the Toxic Substances Control Act (TSCA) PCB Regulations under 40 CFR 761 Subpart D. Three tank lining materials suspected of containing PCB were identified and sampled, generating 12 samples (nine primary and three confirmation) for analysis. All three materials were identified as PCB-containing, with total PCB concentrations ranging from 10.5 mg/kg to 283 mg/kg.

PCB-containing material descriptions and identifiers are provided in Appendix B. Sample and hazardous material location maps are provided in Appendix C. Photographs of suspect materials are provided in Appendix D. Laboratory analytical reports, chains of custody, and field data forms are provided in Appendix E.

**Table 4. Bulk PCB Determination**

Locations	HM ID	Material Color	Material	Substrate	Result (mg/kg)	Estimated Quantity (sq. ft.)
Inside tank floor bottom, debris	13	Beige	Coating	Concrete	Aroclor-1016, 1221, 1232, 1248: ND <b>Aroclor-1242: 2.3</b> <b>Aroclor-1254: 8.1</b> <b>Aroclor-1260: 18</b> Aroclor-1262: ND <u>Aroclor-1268: ND</u> <b>Total PCB: 28.4</b>	3,850
Inside tank sealant joint	14	Beige	Asphaltic base sealant	Concrete	Aroclor-1016, 1221, 1232, 1248: ND <b>Aroclor-1242: 2.4</b> <b>Aroclor-1254: 3.4</b> <b>Aroclor-1260: 4.7</b> Aroclor-1262: ND <u>Aroclor-1268: ND</u> <b>Total PCB: 10.5</b>	220



Locations	HM ID	Material Color	Material	Substrate	Result (mg/kg)	Estimated Quantity (sq. ft.)
Inside tank wall	15	Black	Coating	Concrete	Aroclor-1016, 1221, 1232, 1242, 1248: ND <b>Aroclor-1254: 38</b> <b>Aroclor-1260: 76</b> Aroclor-1262: ND <u>Aroclor-1268: ND</u> <b>Total PCB: 114</b>	4,840
	15C1				Aroclor-1016, 1221, 1232, 1242, 1248: ND <b>Aroclor-1254: 73</b> <b>Aroclor-1260: 210</b> Aroclor-1262: ND <u>Aroclor-1268: ND</u> <b>Total PCB: 283</b>	
	15C2				Aroclor-1016, 1221, 1232, 1242, 1248: ND <b>Aroclor-1254: 51</b> <b>Aroclor-1260: 170</b> Aroclor-1262: ND <u>Aroclor-1268: ND</u> <b>Total PCB: 221</b>	
	15C3				Aroclor-1016, 1221, 1232, 1242, 1248: ND <b>Aroclor-1254: 39</b> <b>Aroclor-1260: 170</b> Aroclor-1262: ND <u>Aroclor-1268: ND</u> <b>Total PCB: 209</b>	

**Bold values indicate results above the reporting limit.**

All three tank liner materials were identified to be in poor condition, indicating that the material shows significant deterioration and may not be functional for its installed purpose.

HMs 15C1, 15C2, and 15C3 are confirmation samples for HM 15, black coating on interior concrete tank walls.

**Abbreviations and Acronyms**

HM ID – Hazardous Material Identifier  
mg/kg – milligrams per kilogram or parts per million  
ND – Not Detected

PCB – Polychlorinated Biphenyls  
sq. ft. – Square Feet

**8.0 SUMMARY OF SURVEY RESULTS**

MNA conducted a hazardous material survey at the County of Kauai DOW Paua Valley 0.5 MG Tank located in Kekaha, Kauai. MNA’s survey was conducted in support of the tank repair and rehabilitation project. The second tank located on the same parcel was not included in the scope of work for this project. No suspected or confirmed hazardous materials were identified on the tank access road that is slated for repaving as part of this project.

Based on the analysis of 21 asbestos samples, 10 lead samples, and 12 PCB coating samples, MNA provides the following summary:

**Summary of Hazardous Material Findings**

	ACM	LCP	LBP	ArCM	PCB
<b>COUNTY OF KAUAI DOW 0.5MG TANK</b>					
Interior	*		☐		☐
Exterior		☐	☐		

☐ indicates presence of hazardous material

\* Indicates presence of materials containing trace asbestos. “Trace” means that one or more asbestos fibers were detected by the point count method. While the less than 1% asbestos is not a regulated material, OSHA considers the trace amount as a health concern.

ACM – Asbestos-Containing Material

LCP – Lead-Containing Paint, <5,000 mg/kg

ArCM – Arsenic-Containing Material

PCB – Polychlorinated Biphenyls

LBP – Lead-Based Paint, ≥5,000 mg/kg

**9.0 RECOMMENDATIONS FOR RENOVATION AND CONSTRUCTION WORK**

It is required that properly trained employees perform construction work and renovation that disturbs hazardous materials, in a manner protective of the site workers, facility users, and the environment. The following recommendations address OSHA and other applicable federal requirements. These recommendations provide guidance for the management of hazardous building materials and control of occupational and environmental hazards associated with operations, maintenance, renovation, and demolition. These recommendations are based on information gathered during the hazardous materials survey. These recommendations are not intended to constitute a formal work plan but are intended to provide a starting point for the development of a work plan or procedure.

**9.1 Asbestos-Containing Materials**

Employees involved in renovation or demolition activities that disturb materials containing trace amounts of asbestos must conduct work in accordance with 29 CFR 1926.1101, the OSHA Asbestos Construction Standard. Work practices that would trigger these requirements include, but are not limited to, repair, maintenance, or renovation of structures containing asbestos, as well as removal or encapsulation of materials containing asbestos. For each project, the contractor must determine the appropriate safety measures based on the area to be disturbed, the type, volume, and condition of materials containing trace amounts of asbestos. Applicable work practice guidelines involving the disturbance of materials containing trace amounts of asbestos are summarized, but are not limited to:

- Employees must utilize appropriate engineering controls and personal protective equipment (PPE). This PPE includes disposable coveralls, gloves, eye protection, steel-

toed boots, a hard hat, and a National Institute for Occupational Safety and Health (NIOSH)-approved appropriate respirator.

- Employers must provide and require the use of appropriate PPE for any employee exposed to airborne concentrations of asbestos that exceed OSHA regulatory limits, or for which a required negative exposure assessment is not produced (29 CFR 1926.1101[i][1]).
- Employees must utilize respiratory protection until the initial exposure monitoring assessment documents safe working levels of airborne asbestos (29 CFR 1926.1101[f] and [h]). Additional periodic exposure monitoring may be required.
- An initial exposure monitoring assessment should be carried out when workers are disturbing ACM or materials containing trace amounts of asbestos to ensure that they are not exposed to airborne asbestos concentrations greater than the Permissible Exposure Limit (PEL) of 0.1 fibers per cubic centimeter (f/cc) of air as an 8-hour time-weighted average (TWA), and the Excursion Limit of 1.0 f/cc over a 30 minute sampling period.
- The work site must be maintained as a controlled regulated area and supervised by a competent person.
- Employees must implement stringent dust control procedures to prevent asbestos in any airborne dust.
- Employees must clean the work area thoroughly using wet methods and a high-efficiency particulate air (HEPA) vacuum. Dry sweeping or air blowing of asbestos debris and dust must be avoided.
- Waste and dust containing ACM or materials containing trace amounts of asbestos must be collected separately from other construction debris. Employees should conduct prompt clean up and disposal of asbestos wastes and debris in leak-tight containers.
- Asbestos-containing waste must be packaged, labeled, stored, and disposed of in accordance with applicable regulations.
- Visually inspect the work area to ensure that all asbestos-containing debris and dust has been properly removed.
- Conduct clearance in accordance with contract specifications.

## 9.2 Lead-Containing Paints

Employees involved in renovation or demolition activities that disturb LCP or LBP must conduct work in accordance with 29 CFR 1926.62 OSHA Lead Construction Standard. Work practices that would trigger these requirements include, but are not limited to, sanding, blasting, welding, cutting, or scraping. For each project, the contractor must determine the appropriate safety measures based on the area to be disturbed, the lead concentration, and the paint condition. Applicable work practice guidelines involving the disturbance of lead paints are summarized, but are not limited to:

- Employees must utilize appropriate engineering controls and personal PPE. The PPE includes disposable coveralls, gloves, eye protection, steel-toed boots, a hard hat, and a NIOSH-approved appropriate respirator.
- Employees must utilize respiratory protection until the initial air monitoring assessment documents safe working levels of airborne lead (29 CFR 1926.62[d][1] and [2][i][A]).
- An exposure assessment should be carried out when employees are disturbing LCP or LBP to ensure that they are not exposed to airborne lead concentrations greater than the PEL of 50 micrograms per cubic meter ( $\mu\text{g}/\text{m}^3$ ) averaged over an 8-hour period. Additional periodic exposure monitoring may be required if the Action Level,  $30 \mu\text{g}/\text{m}^3$ , averaged over an 8-hour period is exceeded.
- Employees must implement stringent dust control procedures to prevent lead in any airborne dust.
- Employees must clean the work area thoroughly using wet methods and a HEPA vacuum. Dry sweeping or air blowing of lead debris and dust must be avoided.
- Lead-containing debris must be segregated from other wastes, collected, and containerized. Wastes must be characterized per State of Hawaii requirements, including a determination of the waste as hazardous or non-hazardous. Lead-containing waste must be handled and disposed of in accordance with applicable requirements.
- Visually inspect and verify the work area to ensure all lead-containing debris and dust has been properly removed and the project site is free of lead hazard.
- Conduct clearance in accordance with contract specifications.

### 9.3 Arsenic-Containing Materials

No arsenic-containing materials were identified in the targeted areas during this survey. Therefore, no special arsenic control measures are provided.

### 9.4 PCB-Containing Bulk Materials

PCBs were detected from the concrete surface of the inside water tank, especially, from floor debris, sealant joint, and coating materials in the range of 2.4 mg/kg and 210 mg/kg. Based on the analytical findings, removal of PCB-containing loose and flaky materials is warranted. The TSCA (40 CFR Part 761), Subpart G – PCB Spill Cleanup Policy, regulates the cleanup and disposal of PCB contamination. This policy establishes criteria that EPA will use to determine the adequacy of the cleanup of spills resulting from the release of materials containing PCBs at concentrations of 50 ppm or greater. The EPA established three cleanup standards based on the site use as follows:

- a) High Occupancy (most stringent clean up level)
- b) Low Occupancy
- c) Industrial Area

These cleanup standards, however, exclude certain spill situations from its scope, such as spills directly into surface waters, **drinking water**, sewers, grazing lands, and vegetable gardens. The PCB concern at the Paua Valley Water Reservoir may fall into category (d) excluded spills, (iii) **Spills that result in the direct contamination of any private or public drinking water sources or distribution systems** under 40 CFR 761.120.

The general requirements under 40 CFR 761.125(a) do apply to the excluded spills. In addition, the excluded situations require practicable, immediate actions to contain the area of contamination. While these situations may not always require more stringent cleanup measures, the EPA is excluding these scenarios because they will always involve significant factors that may not be adequately addressed by cleanup standards based upon typical spill characteristics. Thus, the responsible party shall notify the EPA Regional 9 office and obtain guidance for appropriate cleanup measures in the shortest possible time after discovery, but in no case later than 24 hours after discovery [40 CFR 761.125 (a)(i)].

Since the cleanup measures and levels are not available from the EPA at the time of this reporting, it is recommended to set up the most stringent cleanup goal regulated from TSCA which is the

goal classified as “High Occupancy Areas.” Once EPA’s directions and guidance are available, the clean-up goal and measures shall be implemented.

High occupancy area is generally defined as any area where PCB remediation waste has been disposed of onsite (including but not limited to any building, any floor/wall of the building, any enclosed space within the building), and where annual occupancy for any individual not wearing dermal and respiratory protection is 840 hours or more for non-porous surfaces and 335 hours or more for bulk PCB remediation waste. Examples include residence, school, day care center, sleeping quarters, a single or multiple occupancy 40 hours-per-week work station, a school classroom, a cafeteria in an industrial facility, a control room, and a work station at an assembly line. There are two options to meet the cleanup goal for “High Occupancy Areas” as follows:

- Option 1: clean up the impacted material to be less than or equal to 1 ppm ( $\leq 1$  ppm) in porous surface without further condition
- Option 2: clean up the impacted material between 1 and 10 ppm ( $>1$  to  $\leq 10$  ppm) if site covered with appropriate cap (encapsulation) and institutional control implemented (deed restriction)

Regardless of which option may be selected, the PCB level in the water after the water tank remediation must meet the EPA National Primary Drinking Water Regulations.

Prior to any PCB remediation/cleanup, all PCB work plans must be reviewed and approved by EPA Region 9. The PCB-containing material or PCB waste including demolished debris shall be tested for PCB and disposed of in accordance with TSCA. If PCB concentration of the waste is below the 50 mg/kg, the material may be eligible for disposal at a local landfill as non-TSCA regulated waste. If the results exceed 50 mg/kg, the waste and debris would be classified as TSCA regulated waste which must be disposed of at a permitted hazardous waste landfill or an approved PCB disposal facility, which are currently not available in the State of Hawaii.

Trained workers are required to remove PCB-containing material or waste, and the work must be performed in accordance with OSHA and EPA requirements. Engineering controls and personal protective equipment should be utilized to prevent PCB release or exposure. Applicable work practice guidelines involving PCB-containing materials or waste are summarized, but are not limited to:

- The Contractor shall prepare a Health and Safety Plan (HASP) for PCB remediation/removal work. The HASP shall include accident and emergency response, proper worker protection regarding machinery to be employed during project activities, worker protection from PCB exposure, and required PPE.
- Employees must utilize appropriate PPE. The PPE may include disposable coveralls, gloves, eye protection, steel-toed safety boots, a hard hat, and a NIOSH-approved appropriate respirator.
- All work involving PCB should be performed by properly trained and equipped personnel.
- Establish PCB controlled areas for removal or spill cleanup to prevent unauthorized entry of personnel. Maintain a log of employees working in PCB controlled areas.
- All PCB waste should be stored and disposed of in compliance with TSCA regulations, and all records involving PCB should be properly maintained.

## **10.0 LIMITATIONS**

Industry standard effort was made to identify suspected hazardous building materials during the survey at the project area. However, this does not imply a guarantee that all suspected building materials and hazardous materials were identified by this assessment because certain building materials and/or surfaces may be hidden by walls, flooring, partitions, or other building components. If any previously unforeseen suspected materials become uncovered, additional survey may be required prior to the planned tank repair and rehabilitation project.

Material quantities provided in this report are based on visual approximations taken at the time of the survey only and should not be used for bidding purpose. It is the Contractor's responsibility to determine the material quantities and volume of waste prior to bidding.

## **APPENDIX A**

### **INSPECTOR CERTIFICATIONS**

**Akari Ihara**

**Danny Falanug**





# State of Hawai'i Asbestos Certification

## Training Course Exp. Dates

W	n/a	MP	n/a
CS	n/a	PD	n/a
INS	10/10/18	PM	09/21/18

**Ihara**  
 Akari R.  
 Myounghee Noh & Associates, L.L.C.  
**HIASB-1014**  
 State Exp. Date **04/20/2018**

W= Worker  
 CS= Cont./Sup.  
 INS= Inspector  
 PD= Project Designer  
 MP= Mgmt. Planner  
 PM= Project Monitor

# State of Hawai'i Lead Based Paint Activities Certification

## Expiration Dates:

Inspector-	n/a
Supervisor-	n/a
Risk Assessor-	09/17/2019
Project Designer-	n/a
Worker-	n/a

**Ihara**  
**Akari**

Certification # PB-0056





# State of Hawai'i Asbestos Certification

## Training Course Exp. Dates

W	n/a	MP	n/a
CS	n/a	PD	n/a
INS	05/18/18	PM	05/19/18

W= Worker  
 CS= Cont./Sup.  
 INS= Inspector  
 PD= Project Designer  
 MP= Mgmt. Planner  
 PM= Project Monitor

**Falanug**

Danny  
Myounghee Noh & Associates, L.L.C.

**HIASB-3526**

**State Exp. Date 05/25/2018**

# State of Hawai'i Lead Based Paint Activities Certification

## Expiration Dates:

Inspector-	08/12/2019
Supervisor-	n/a
Risk Assessor-	n/a
Project Designer-	n/a
Worker-	n/a

**Falanug**

**Danny**

Certification # PB-0661



## **APPENDIX B**

### **HOMOGENEOUS MATERIALS IDENTIFIED AND SAMPLE TYPES COLLECTED**

**Homogeneous Materials Identified and Sample Types Collected**

HM ID	Floor	Rooms	Locations	Material Color	Material	Substrate	Asb	Pb	PCB	Result
1	R	Exterior	Roofing system	Lt. blue	Paint	Concrete		X		LCP 710 - 1,200 mg/kg
2	R	Exterior	Roofing system	Lt. blue	Paint/skim coat	Concrete	X			ND
3	R	Exterior	Vent	Gray	Cement board	Concrete	X			ND
4	R	Exterior	Hatch	Dk. green	Paint	Metal		X		LBP 41,000 - 55,000 mg/kg
5	R	Exterior	Handrail, ladder	Lt. green	Paint	Metal		X		LCP 1,200 - 1,400 mg/kg
6	1	Interior	Floor	Beige	Coating	Concrete		X		LBP 40,000 - 41,000 mg/kg
7	1	Interior	Floor	Beige	Coating Cement material	Concrete	X			ND <0.25%* Chrysotile
8	1	Interior	Sealant joint	Beige	Coating Texture Tar	Concrete	X			ND
9	1	Interior	Walls	Black	Coating	Concrete	X			ND
10	1	Exterior	Walls	Orange	Paint	Concrete		X		<40 mg/kg
11	1	Exterior	Walls	Orange	Paint/skim coat	Concrete	X			ND
12	1	Exterior	Walls	Beige	Paint	Concrete		X		<40 mg/kg

**Homogeneous Materials Identified and Sample Types Collected**

HM ID	Floor	Rooms	Locations	Material Color	Material	Substrate	Asb	Pb	PCB	Result
13	1	Interior	Floor, debris	Beige	Coating	Concrete			X	Aroclor-1016, 1221, 1232, 1248: ND <b>Aroclor-1242: 2.3</b> <b>Aroclor-1254: 8.1</b> <b>Aroclor-1260: 18</b> Aroclor-1262: ND Aroclor-1268: ND <b>Total PCB: 28.4</b>
14	1	Interior	Sealant joint	Beige	Asphaltic base sealant	Concrete			X	Aroclor-1016, 1221, 1232, 1248: ND <b>Aroclor-1242: 2.4</b> <b>Aroclor-1254: 3.4</b> <b>Aroclor-1260: 4.7</b> Aroclor-1262: ND Aroclor-1268: ND <b>Total PCB: 10.5</b>
15	1	Interior	Walls	Black	Coating	Concrete			X	Aroclor-1016, 1221, 1232, 1242, 1248: ND <b>Aroclor-1254: 38</b> <b>Aroclor-1260: 76</b> Aroclor-1262: ND Aroclor-1268: ND <b>Total PCB: 114</b>
15C1	1	Interior	Walls	Black	Coating	Concrete			X	Aroclor-1016, 1221, 1232, 1242, 1248: ND <b>Aroclor-1254: 73</b> <b>Aroclor-1260: 210</b> Aroclor-1262: ND Aroclor-1268: ND <b>Total PCB: 283</b>

### Homogeneous Materials Identified and Sample Types Collected

HM ID	Floor	Rooms	Locations	Material Color	Material	Substrate	Asb	Pb	PCB	Result
15C2	1	Interior	Walls	Black	Coating	Concrete			X	Aroclor-1016, 1221, 1232, 1242, 1248: ND <b>Aroclor-1254: 51</b> <b>Aroclor-1260: 170</b> Aroclor-1262: ND Aroclor-1268: ND <b>Total PCB: 221</b>
15C3	1	Interior	Walls	Black	Coating	Concrete			X	Aroclor-1016, 1221, 1232, 1242, 1248: ND <b>Aroclor-1254: 39</b> <b>Aroclor-1260: 170</b> Aroclor-1262: ND Aroclor-1268: ND <b>Total PCB: 209</b>
9C1	1	Interior	Walls	Black	Coating	Concrete	X			ND

**Bold values indicate results above the reporting limit.**

\* Indicates that one or more asbestos fibers were detected by the point count method. While the less than 1% asbestos is not a regulated material, OSHA considers the trace amount as a health concern.

HM 9C1 is a confirmation sample for HM 9.

HM 15C1, 15C2, and 15C3 are confirmation samples for HM 15.

Abbreviations and Acronyms

Asb - Asbestos

HM ID - Homogeneous Material Identifier

LBP - Lead-Based Paint ≥5,000 mg/kg

LCP - Lead-Containing Paint <5,000 mg/kg

mg/kg - milligrams per kilogram, equivalent to parts per million

ND - Not Detected

Pb - Lead

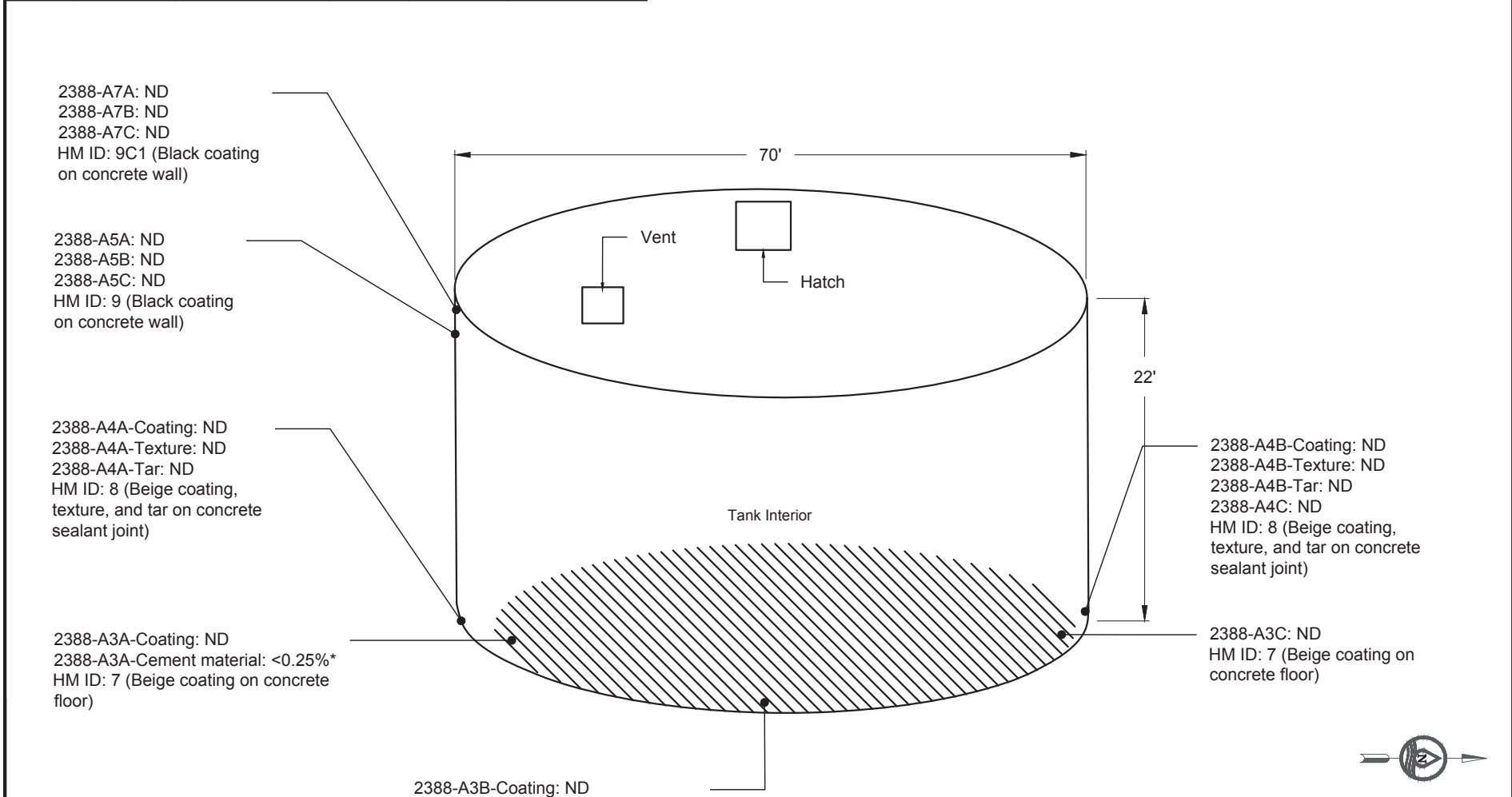
PCB - Polychlorinated Biphenyls

## APPENDIX C

### SAMPLE AND HAZARDOUS MATERIAL LOCATION DRAWINGS

<b>List of Drawings</b>	
Asbestos and Lead Sample and Hazardous Material Locations Tank Interior	C-1 – C-3
Asbestos and Lead Sample and Hazardous Material Locations Tank Exterior	C-4 – C-5

HM ID	Locations	Material	Color	Substrate	Results
7	Floor	Coating Cement Material	Beige	Concrete	Trace <0.25%*



Legend and Notes

**Visual Extent of Trace Asbestos**

All asbestos found to be chrysotile.

\* - Indicates that one or more asbestos fibers were detected by the point count method. While the less than 1% asbestos is not a regulated material, OSHA considers the trace amount as a health concern.

HM ID - Homogeneous Material Identifier

ND - None Detected



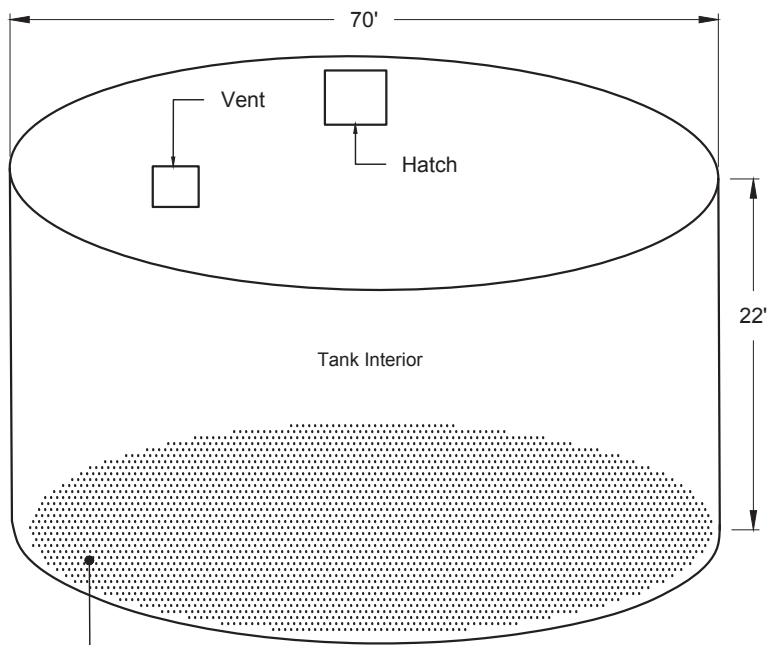
Myounghee Noh & Associates, L.L.C.

Asbestos Sample and Hazardous Material Locations  
Kauai Department of Water Repair of Kekaha  
0.6 MG Concrete Storage Tank Interior

Sheet Number  
C - 1



HM ID	Locations	Color	Material	Substrate	Results (mg/kg)
6	Floor	Beige	Coating	Concrete	<b>LBP 40,000 - 41,000</b>



**2388-P4A: LBP 41,000 mg/kg**  
**2388-P4B: LBP 40,000 mg/kg**  
**HM ID: 6 (Beige coating on concrete floor)**



Legend and Notes

**Visual Extent of Lead-Based Paint**

**Bold values indicate results above the detection limit.**

HM ID - Hazardous Material Identifier

LCP - Lead-Containing Paint < 5,000 mg/kg

mg/kg - milligrams per kilogram (equivalent to ppm- parts per million)

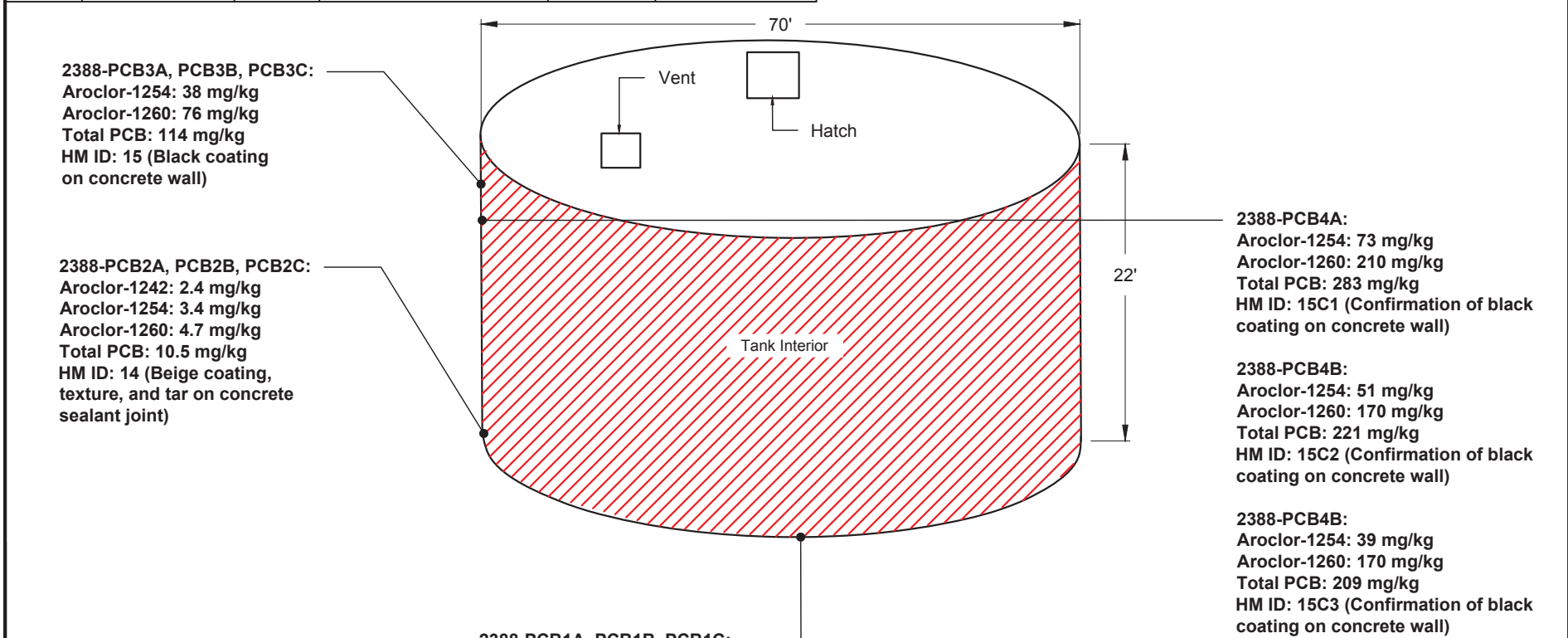


Myounghee Noh & Associates, L.L.C.

Lead Sample and Hazardous  
Material Locations  
Kauai Department of Water Repair of Kekaha  
0.6 MG Concrete Storage Tank Interior

Sheet Number  
C - 2

HM ID	Locations	Color	Material	Substrate	Results (mg/kg)
13	Floor, debris	Beige	Coating	Concrete	<b>Total PCB: 28.4</b>
14	Sealant joint	Beige	Coating, texture, and tar	Concrete	<b>Total PCB: 10.5</b>
15	Wall	Black	Coating	Concrete	<b>Total PCB: 114</b>
15C1	Wall	Black	Coating	Concrete	<b>Total PCB: 283</b>
15C2	Wall	Black	Coating	Concrete	<b>Total PCB: 221</b>
15C3	Wall	Black	Coating	Concrete	<b>Total PCB: 209</b>



Legend and Notes

Visual Extent of PCB-Containing Material

**Bold values indicate results above the detection limit.**

ND - None Detected

PCB - Polychlorinated Biphenyls

mg/kg - milligrams per kilogram (equivalent to ppm- parts per million)

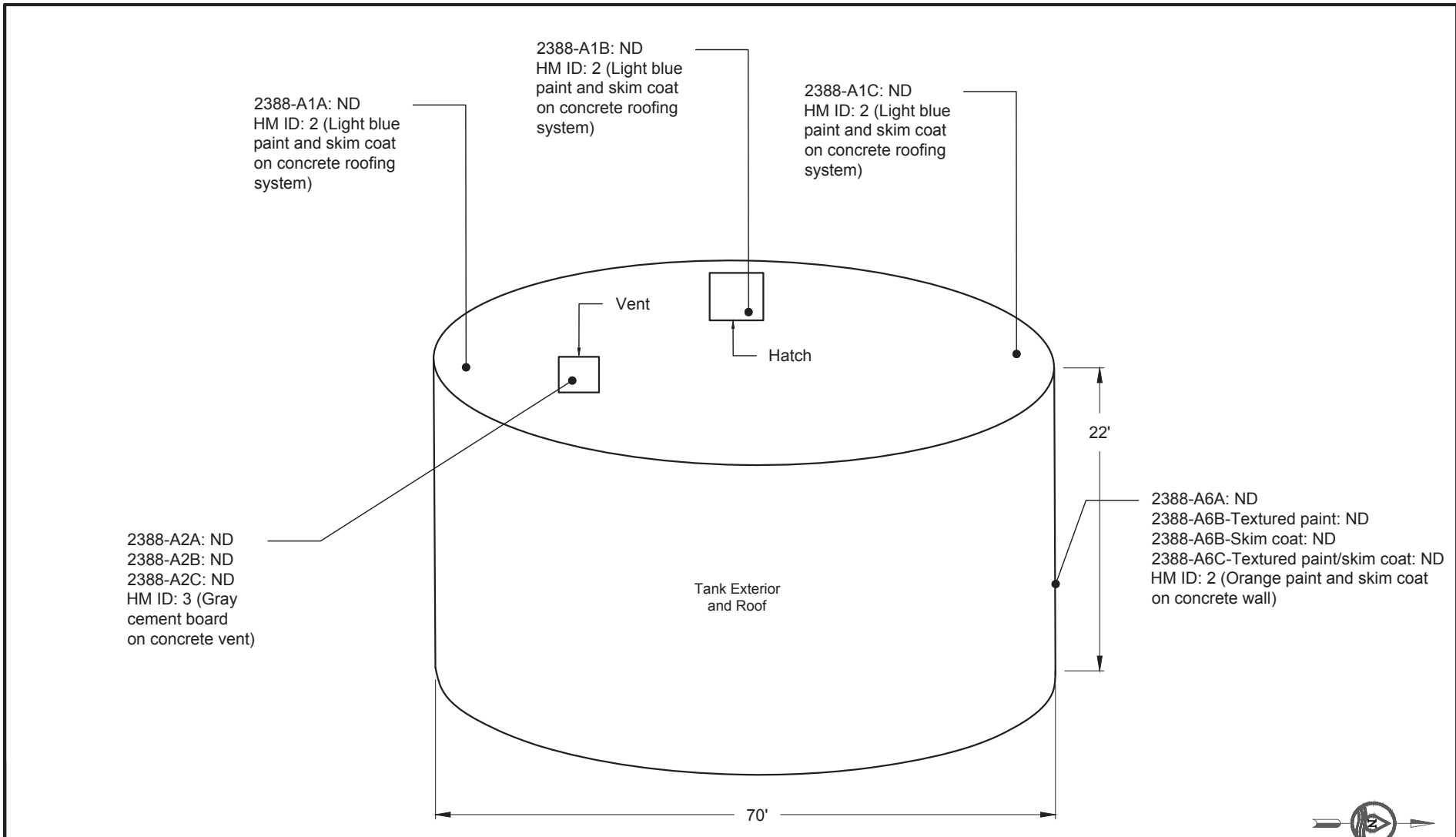


Myounghee Noh & Associates, L.L.C.

PCB Sample and Hazardous  
 Material Locations  
 Kauai Department of Water Repair of Kekaha  
 0.6 MG Concrete Storage Tank Interior

Sheet Number

C - 3



Myounghee Noh & Associates, L.L.C.

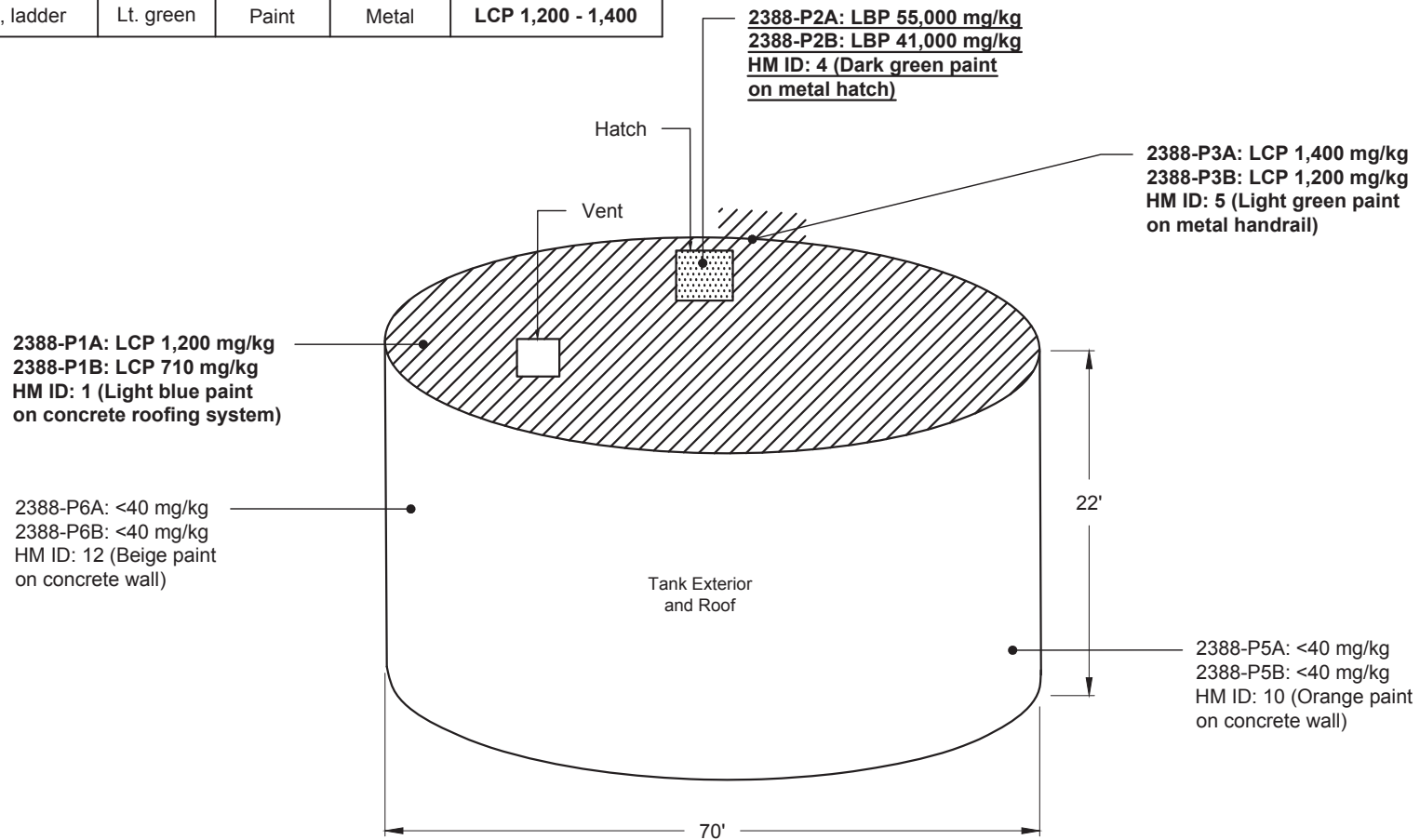
Legend and Notes

HM ID - Homogeneous Material Identifier  
ND - None Detected


Asbestos Sample Locations  
Kauai Department of Water Repair of Kekaha  
0.6 MG Concrete Storage Tank  
Exterior and Roof

Sheet Number  
C - 4

HM ID	Locations	Color	Material	Substrate	Results (mg/kg)
1	Roofing system	Lt. blue	Paint	Concrete	<b>LCP 710 - 1,200</b>
4	Hatch	Dk. green	Paint	Metal	<b>LBP 41,000 - 55,000</b>
5	Handrail, ladder	Lt. green	Paint	Metal	<b>LCP 1,200 - 1,400</b>



Legend and Notes

 Visual Extent of Lead-Based Paint

 Visual Extent of Lead-Containing Paint

**Bold values indicate results above the detection limit.**

HM ID - Hazardous Material Identifier

LBP - Lead-Based Paint  $\geq 5,000$  mg/kg

LCP - Lead-Containing Paint < 5,000 mg/kg

mg/kg - milligrams per kilogram (equivalent to ppm- parts per million)



Myounghee Noh & Associates, L.L.C.

Lead Sample and Hazardous Material Locations  
Kauai Department of Water Repair of Kekaha 0.6  
MG Concrete Storage Tank Exterior and Roof

Sheet Number

C - 5

## **APPENDIX D**

## **PHOTOGRAPHS**



HM ID: 1  
0.5 MG Tank  
Roof

Exterior  
Light blue paint on concrete roofing system.

LCP  
2388-P1A: 1,200 mg/kg  
2388-P1B: 710 mg/kg



HM ID: 2  
0.5 MG Tank  
Roof

Exterior  
Light blue paint and skim coat on concrete roofing system.

Non-ACM  
2388-A1A: ND  
2388-A1B: ND  
2388-A1C: ND



HM ID: 3  
0.5 MG Tank  
Roof

Exterior  
Gray cement board on concrete vent.

Non-ACM  
2388-A2A: ND  
2388-A2B: ND  
2388-A2C: ND



HM ID: 4  
0.5 MG Tank  
Roof

Exterior  
Dark green paint on metal hatch.

**LBP**  
**2388-P2A: 55,000 mg/kg**  
**2388-P2B: 41,000 mg/kg**



HM ID: 5  
0.5 MG Tank  
Roof

Exterior  
Light green paint on metal handrail.

**LCP**  
**2388-P3A: 1,400 mg/kg**  
**2388-P3B: 2,100 mg/kg**



HM ID: 6  
0.5 MG Tank  
Floor 1

Interior  
Beige coating on concrete floor.

**LBP**  
**2388-P4A: 41,000 mg/kg**  
**2388-P4B: 40,000 mg/kg**



HM ID: 7  
0.5 MG Tank  
Floor 1

Interior  
Beige coating on concrete floor.

Trace ACM\*

2388-A3A-Coating: ND  
2388-A3A-Cementitious Material: <0.25% Chrysotile  
2388-A3B-Coating: ND  
2388-A3B-Cementitious Material: <0.25% Chrysotile  
2388-A3C: ND



HM ID: 8  
0.5 MG Tank  
Floor 1

Interior  
Beige asphaltic base sealant on concrete sealant joint.

Non-ACM

2388-A4A- Coating: ND  
2388-A4A-Texture: ND  
2388-A4A-Tar: ND  
2388-A4B-Coating: ND  
2388-A4B-Texture: ND  
2388-A4B-Tar: ND  
2388-A4C-Coating: ND  
2388-A4C-Texture: ND  
2388-A4C-Tar: ND



HM ID: 9  
0.5 MG Tank  
Floor 1

Interior  
Black coating on concrete wall.

Non-ACM

2388-A5A: ND  
2388-A5B: ND  
2388-A5C: ND

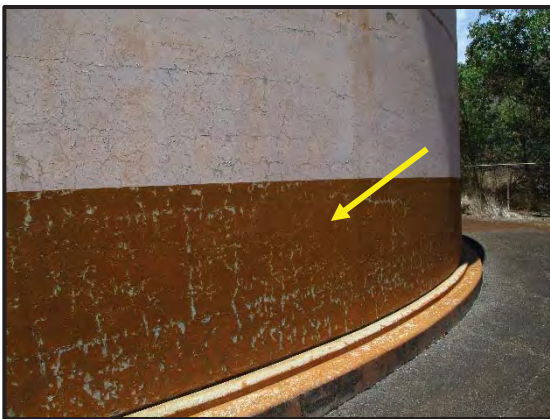




HM ID: 10  
0.5 MG Tank  
Floor 1

Exterior  
Orange paint on concrete wall.

Non-LCP  
2388-P5A: <40 mg/kg  
2388-P5B: <40 mg/kg



HM ID: 11  
0.5 MG Tank  
Floor 1

Exterior  
Orange paint and skim coat on concrete wall.

Non-ACM  
2388-A6A: ND  
2388-A6B-Texture Paint: ND  
2388-A6B-Skim Coat: ND  
2388-A6C-Texture Paint/Skim Coat: ND



HM ID: 12  
0.5 MG Tank  
Floor 1

Exterior  
Beige paint on concrete wall.

Non-LCP  
2388-P6A: <40 mg/kg  
2388-P6B: <40 mg/kg



HM ID: 13  
0.5 MG Tank  
Floor 1

Interior  
Beige coating on concrete floor.

**2388-PCB1A, PCB1B, PCB1C:**

Aroclor-1016: ND  
Aroclor-1221: ND  
Aroclor-1232: ND  
**Aroclor-1242: 2.3 mg/kg**  
Aroclor-1248: ND  
**Aroclor-1254: 8.1 mg/kg**  
**Aroclor-1260: 18 mg/kg**  
Aroclor-1262: ND  
Aroclor-1268: ND  
**Total PCB: 28.4 mg/kg**



HM ID: 14  
0.5 MG Tank  
Floor 1

Interior  
Beige asphaltic base sealant on concrete sealant joint.

**2388-PCB2A, PCB2B, PCB2C:**

Aroclor-1016: ND  
Aroclor-1221: ND  
Aroclor-1232: ND  
**Aroclor-1242: 2.4 mg/kg**  
Aroclor-1248: ND  
**Aroclor-1254: 3.4 mg/kg**  
**Aroclor-1260: 4.7 mg/kg**  
Aroclor-1262: ND  
Aroclor-1268: ND  
**Total PCB: 10.5 mg/kg**

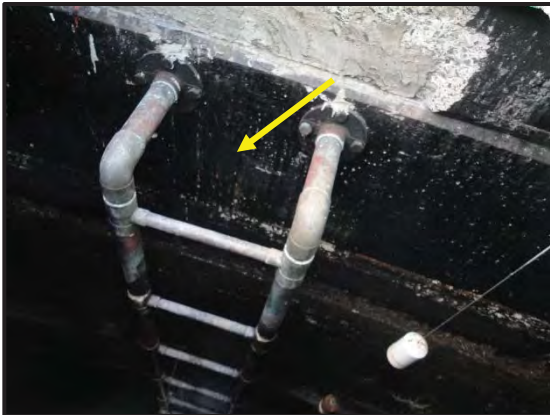


HM ID: 15  
0.5 MG Tank  
Floor 1

Interior  
Black coating on concrete wall.

**2388-PCB3A, PCB3B, PCB3C:**

Aroclor-1016: ND  
Aroclor-1221: ND  
Aroclor-1232: ND  
Aroclor-1242: ND  
Aroclor-1248: ND  
**Aroclor-1254: 38 mg/kg**  
**Aroclor-1260: 76 mg/kg**  
Aroclor-1262: ND  
Aroclor-1268: ND  
**Total PCB: 114 mg/kg**



HM ID: 15C1 (Confirmation Sample)  
0.5 MG Tank  
Floor 1

Interior  
Black coating on concrete wall.

**2388-PCB4A, PCB4B, PCB4C:**

Aroclor-1016: ND  
Aroclor-1221: ND  
Aroclor-1232: ND  
Aroclor-1242: ND  
Aroclor-1248: ND  
**Aroclor-1254: 73 mg/kg**  
**Aroclor-1260: 210 mg/kg**  
Aroclor-1262: ND  
Aroclor-1268: ND  
**Total PCB: 283 mg/kg**



HM ID: 15C2 (Confirmation Sample)  
0.5 MG Tank  
Floor 1

Interior  
Black coating on concrete wall.

**2388-PCB4A, PCB4B, PCB4C:**

Aroclor-1016: ND

Aroclor-1221: ND

Aroclor-1232: ND

Aroclor-1242: ND

Aroclor-1248: ND

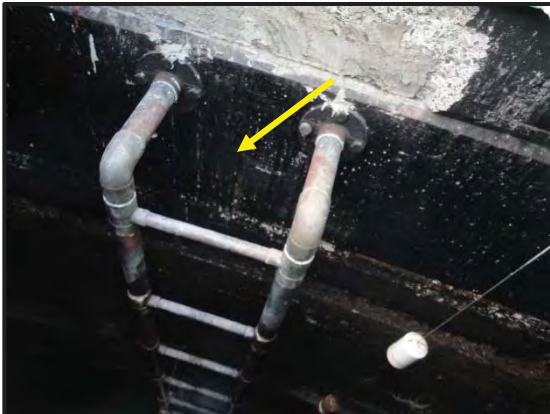
**Aroclor-1254: 51 mg/kg**

**Aroclor-1260: 170 mg/kg**

Aroclor-1262: ND

Aroclor-1268: ND

**Total PCB: 221 mg/kg**



HM ID: 15C3 (Confirmation Sample)  
0.5 MG Tank  
Floor 1

Interior  
Black coating on concrete wall.

**2388-PCB4A, PCB4B, PCB4C:**

Aroclor-1016: ND

Aroclor-1221: ND

Aroclor-1232: ND

Aroclor-1242: ND

Aroclor-1248: ND

**Aroclor-1254: 39 mg/kg**

**Aroclor-1260: 170 mg/kg**

Aroclor-1262: ND

Aroclor-1268: ND

**Total PCB: 209 mg/kg**



HM ID: 9C1 (Confirmation)  
0.5 MG Tank  
Floor 1

Interior  
Black coating on concrete wall.

Non-ACM  
2388-A7A: ND  
2388-A7B: ND  
2388-A7C: ND

\*Indicates that one or more asbestos fibers were detected by the point count method. While the <1% asbestos is not a regulated material, OSHA considers the trace amount as a health hazard.

## **APPENDIX E**

### **LABORATORY ANALYTICAL REPORTS**



# LA Testing

520 Mission Street South Pasadena, CA 91030

Tel/Fax: (323) 254-9960 / (323) 254-9982

<http://www.LATesting.com> / [pasadenalab@latesting.com](mailto:pasadenalab@latesting.com)

LA Testing Order: 321720066

Customer ID: 32MYOU50

Customer PO:

Project ID:

**Attention:** Akari Ihara  
Myounghee Noh & Associates, LLC  
99-1046 Iwaena Street  
Suite 210A  
Aiea, HI 96701

**Phone:** (808) 358-1421

**Fax:**

**Received Date:** 08/21/2017 9:20 AM

**Analysis Date:** 08/25/2017

**Collected Date:**

**Project:** 2388.3

## Test Report: Asbestos Analysis of Bulk Materials via EPA 600/R-93/116 Method using Polarized Light Microscopy

Sample	Description	Appearance	Non-Asbestos		Asbestos
			% Fibrous	% Non-Fibrous	% Type
2388.A1A <small>321720066-0001</small>	Ext Roof System - P/SC	Gray Non-Fibrous Homogeneous		100% Non-fibrous (Other)	None Detected
2388.A1B <small>321720066-0002</small>	Ext Roof System - P/SC	Green Non-Fibrous Homogeneous		100% Non-fibrous (Other)	None Detected
2388.A1C <small>321720066-0003</small>	Ext Roof System - P/SC	Green/Beige Non-Fibrous Homogeneous		100% Non-fibrous (Other)	None Detected
2388.A2A <small>321720066-0004</small>	Ext Vent - Gray cementitas	Gray Non-Fibrous Homogeneous		100% Non-fibrous (Other)	None Detected
2388.A2B <small>321720066-0005</small>	Ext Vent - Gray cementitas	Gray Non-Fibrous Homogeneous		100% Non-fibrous (Other)	None Detected
2388.A2C <small>321720066-0006</small>	Ext Vent - Gray cementitas	Gray Non-Fibrous Homogeneous		100% Non-fibrous (Other)	None Detected
2388.A3A-Coating <small>321720066-0007</small>	Lut Floor - beige coating	Beige/Orange Non-Fibrous Homogeneous		100% Non-fibrous (Other)	None Detected
2388.A3A-Cementitious Material <small>321720066-0007A</small>	Lut Floor - beige coating	Brown/Gray Non-Fibrous Homogeneous		100% Non-fibrous (Other)	<1% Chrysotile
2388.A3B-Coating <small>321720066-0008</small>	Lut Floor - beige coating	Beige/Orange Non-Fibrous Homogeneous		100% Non-fibrous (Other)	None Detected
2388.A3B-Cementitious Material <small>321720066-0008A</small>	Lut Floor - beige coating	Gray Non-Fibrous Homogeneous		100% Non-fibrous (Other)	<1% Chrysotile
2388.A3C <small>321720066-0009</small>	Lut Floor - beige coating	Beige/Orange Non-Fibrous Homogeneous		100% Non-fibrous (Other)	None Detected
2388.A4A-Coating <small>321720066-0010</small>	Lut Sealant Joint - beige asphalt base sealant	Orange Non-Fibrous Homogeneous		100% Non-fibrous (Other)	None Detected
2388.A4A-Texture <small>321720066-0010A</small>	Lut Sealant Joint - beige asphalt base sealant	Gray Non-Fibrous Homogeneous		100% Non-fibrous (Other)	None Detected
2388.A4A-Tar <small>321720066-0010B</small>	Lut Sealant Joint - beige asphalt base sealant	Black Non-Fibrous Homogeneous		100% Non-fibrous (Other)	None Detected
2388.A4B-Coating <small>321720066-0011</small>	Lut Sealant Joint - beige asphalt base sealant	Orange Non-Fibrous Homogeneous		100% Non-fibrous (Other)	None Detected

Initial report from: 08/25/2017 14:24:05



# LA Testing

520 Mission Street South Pasadena, CA 91030

Tel/Fax: (323) 254-9960 / (323) 254-9982

http://www.LATesting.com / pasadenalab@lateesting.com

LA Testing Order: 321720066

Customer ID: 32MYOU50

Customer PO:

Project ID:

## Test Report: Asbestos Analysis of Bulk Materials via EPA 600/R-93/116 Method using Polarized Light Microscopy

Sample	Description	Appearance	Non-Asbestos		Asbestos
			% Fibrous	% Non-Fibrous	% Type
2388.A4B-Texture <small>321720066-0011A</small>	Lut Sealant Joint - beige asphalt base sealant	Gray Non-Fibrous Homogeneous		100% Non-fibrous (Other)	None Detected
2388.A4B-Tar <small>321720066-0011B</small>	Lut Sealant Joint - beige asphalt base sealant	Black Non-Fibrous Homogeneous		100% Non-fibrous (Other)	None Detected
2388.A4C <small>321720066-0012</small>	Lut Sealant Joint - beige asphalt base sealant	Black Non-Fibrous Homogeneous		100% Non-fibrous (Other)	None Detected
2388.A5A <small>321720066-0013</small>	Lut Walls - black coating	Black Non-Fibrous Homogeneous		100% Non-fibrous (Other)	None Detected
2388.A5B <small>321720066-0014</small>	Lut Walls - black coating	Black Non-Fibrous Homogeneous		100% Non-fibrous (Other)	None Detected
2388.A5C <small>321720066-0015</small>	Lut Walls - black coating	Black Non-Fibrous Homogeneous		100% Non-fibrous (Other)	None Detected
2388.A6A <small>321720066-0016</small>	Ext Walls - orange P/SC	Orange Non-Fibrous Homogeneous		100% Non-fibrous (Other)	None Detected
2388.A6B-Texture Paint <small>321720066-0017</small>	Ext Walls - orange P/SC	Orange Non-Fibrous Homogeneous		100% Non-fibrous (Other)	None Detected
2388.A6B-Skim Coat <small>321720066-0017A</small>	Ext Walls - orange P/SC	Gray Non-Fibrous Homogeneous		100% Non-fibrous (Other)	None Detected
2388.A6C-Texture Paint/Skim Coat <small>321720066-0018</small>	Ext Walls - orange P/SC	Gray/Orange Non-Fibrous Heterogeneous		100% Non-fibrous (Other)	None Detected

Unable to separate.

Analyst(s)

Julie Vong (6)

Kieu-anh Pham Duong (19)

Jerry Drapala Ph.D, Laboratory Manager  
or Other Approved Signatory

EMSL maintains liability limited to cost of analysis. This report relates only to the samples reported and may not be reproduced, except in full, without written approval by EMSL. EMSL bears no responsibility for sample collection activities or analytical method limitations. Interpretation and use of test results are the responsibility of the client. This report must not be used by the client to claim product certification, approval, or endorsement by NVLAP, NIST or any agency of the federal government. Non-friable organically bound materials present a problem matrix and therefore EMSL recommends gravimetric reduction prior to analysis. Samples received in good condition unless otherwise noted. Estimated accuracy, precision and uncertainty data available upon request. Unless requested by the client, building materials manufactured with multiple layers (i.e. linoleum, wallboard, etc.) are reported as a single sample. Reporting limit is 1%

Samples analyzed by LA Testing South Pasadena, CA NVLAP Lab Code 200232-0, CA ELAP 2283

Initial report from: 08/25/2017 14:24:05





**Asbestos Chain of Custody**  
**EMSL Order Number (Lab Use Only):**

#321720066

LATESTING  
 520 MISSION STREET  
 SOUTH PASADENA, CA 91030  
 PHONE: (800)-303-0047  
 FAX: (323)-254-9962

Company : Myounghee Noh & Associates L.L.C		EMSL-Bill to: <input type="checkbox"/> Same <input type="checkbox"/> Different If Bill to is Different note instructions in Comments**	
Street: 99-1046 Iwaena St.		Third Party Billing requires written authorization from third party	
City: Aiea	State/Province: Hawaii	Zip/Postal Code:	Country:
Report To (Name): AKari		Telephone #:	
Email Address:		Fax #:	Purchase Order:
Project Name/Number: 2388-3		Please Provide Results: <input type="checkbox"/> Fax <input type="checkbox"/> Email <input type="checkbox"/> Mail	
U.S. State Samples Taken: 4		Connecticut Samples: <input type="checkbox"/> Commercial <input type="checkbox"/> Residential	

**Turnaround Time (TAT) Options\* - Please Check**

3 Hour  6 Hour  24 Hour  48 Hour  72 Hour  96 Hour  1 Week  2 Week

\*For TEM Air 3 hr through 6 hr, please call ahead to schedule. \*There is a premium charge for 3 Hour TEM AHERA or EPA Level II TAT. You will be asked to sign an authorization form for this service. Analysis completed in accordance with EMSL's Terms and Conditions located in the Analytical Price Guide.

<b>PCM - Air</b> <input type="checkbox"/> Check if samples are from NY <input type="checkbox"/> NIOSH 7400 <input type="checkbox"/> w/ OSHA 8hr. TWA	<b>TEM - Air</b> <input type="checkbox"/> 4-4.5hr TAT (AHERA only) <input type="checkbox"/> AHERA 40 CFR, Part 763 <input type="checkbox"/> NIOSH 7402 <input type="checkbox"/> EPA Level II <input type="checkbox"/> ISO 10312	<b>TEM - Dust</b> <input type="checkbox"/> Microvac - ASTM D 5755 <input type="checkbox"/> Wipe - ASTM D6480 <input type="checkbox"/> Carpet Sonication (EPA 600/J-93/167)
<b>PLM - Bulk (reporting limit)</b> <input checked="" type="checkbox"/> PLM EPA 600/R-93/116 (<1%) <input type="checkbox"/> PLM EPA NOB (<1%) Point Count <input type="checkbox"/> 400 (<0.25%) <input type="checkbox"/> 1000 (<0.1%) Point Count w/Gravimetric <input type="checkbox"/> 400 (<0.25%) <input type="checkbox"/> 1000 (<0.1%) <input type="checkbox"/> NYS 198.1 (friable in NY) <input type="checkbox"/> NYS 198.6 NOB (non-friable-NY) <input type="checkbox"/> NIOSH 9002 (<1%)	<b>TEM - Bulk</b> <input type="checkbox"/> TEM EPA NOB <input type="checkbox"/> NYS NOB 198.4 (non-friable-NY) <input type="checkbox"/> Chatfield SOP <input type="checkbox"/> TEM Mass Analysis-EPA 600 sec. 2.5	<b>Soil/Rock/Vermiculite</b> <input type="checkbox"/> PLM CARB 435 - A (0.25% sensitivity) <input type="checkbox"/> PLM CARB 435 - B (0.1% sensitivity) <input type="checkbox"/> TEM CARB 435 - B (0.1% sensitivity) <input type="checkbox"/> TEM CARB 435 - C (0.01% sensitivity) <input type="checkbox"/> TEM Qual. via Filtration Technique <input type="checkbox"/> TEM Qual. via Drop-Mount Technique
<input checked="" type="checkbox"/> Check For Positive Stop - Clearly Identify Homogenous Group		<b>Filter Pore Size (Air Samples):</b> <input type="checkbox"/> 0.8µm <input type="checkbox"/> 0.45µm

Samplers Name: AKari Samplers Signature: *AKari*

Sample #	Sample Description	Volume/Area (Air) HA # (Bulk)	Date/Time Sampled
2388-A1A ↓ ↓ B	bulk		
↓ ↓ C			
2388-A6A ↓ ↓ B			
↓ ↓ C			

Client Sample # (s): 2388-A1A ~ 2388-A6C Total # of Samples: 18

Relinquished (Client): *AKari* Date: 8.18.17 Time:

Received (Lab): D Flores (EMSL FedEx) Date: 8/21/17 Time: 9:20 am

Comments/Special Instructions:

#321720066

**Hazardous Homogeneous Materials and Sampling Survey Field Form: Asbestos**

Project Number: 2388 3 Location: DOW Kekaha 0.5MG Storage Tank Inspector Initials: AI Survey Dates and Times: 2.17.17

HM ID	Building	Fir.	Rooms	Locations	Material Color	Material	Substrate	Condition	Friable ACM Type	Area Sq. ft or L. ft	Hatch Color																				
2	0.5 MG Tank	R	ext	Roofsystem	H-blue	P/Sc	cc	GFP	Y TSI S(M)	2,000	-																				
<table border="1"> <thead> <tr> <th>Sample ID</th> <th>Room Sampled</th> <th>Sample Location</th> <th>PIC ID</th> <th>Notes</th> </tr> </thead> <tbody> <tr> <td>2388-A 1 A</td> <td>ext</td> <td>Roofsystem</td> <td>1499</td> <td></td> </tr> <tr> <td>2388-A 1 B</td> <td>↓</td> <td></td> <td></td> <td></td> </tr> <tr> <td>2388-A 1 C</td> <td></td> <td></td> <td></td> <td></td> </tr> </tbody> </table>												Sample ID	Room Sampled	Sample Location	PIC ID	Notes	2388-A 1 A	ext	Roofsystem	1499		2388-A 1 B	↓				2388-A 1 C				
Sample ID	Room Sampled	Sample Location	PIC ID	Notes																											
2388-A 1 A	ext	Roofsystem	1499																												
2388-A 1 B	↓																														
2388-A 1 C																															
3	0.5 MG Tank	R	ext	vent	gray	concretitas	cc	GFP	Y TSI S(M)	5	-																				
<table border="1"> <thead> <tr> <th>Sample ID</th> <th>Room Sampled</th> <th>Sample Location</th> <th>PIC ID</th> <th>Notes</th> </tr> </thead> <tbody> <tr> <td>2388-A 2 A</td> <td>ext</td> <td>vent</td> <td>1493</td> <td></td> </tr> <tr> <td>2388-A 2 B</td> <td>↓</td> <td></td> <td></td> <td></td> </tr> <tr> <td>2388-A 2 C</td> <td></td> <td></td> <td></td> <td></td> </tr> </tbody> </table>												Sample ID	Room Sampled	Sample Location	PIC ID	Notes	2388-A 2 A	ext	vent	1493		2388-A 2 B	↓				2388-A 2 C				
Sample ID	Room Sampled	Sample Location	PIC ID	Notes																											
2388-A 2 A	ext	vent	1493																												
2388-A 2 B	↓																														
2388-A 2 C																															
7	0.5 MG Tank	int	int	floor	beige	Coatings	cc	GFP	Y TSI S(M)	5000	-																				
<table border="1"> <thead> <tr> <th>Sample ID</th> <th>Room Sampled</th> <th>Sample Location</th> <th>PIC ID</th> <th>Notes</th> </tr> </thead> <tbody> <tr> <td>2388-A 3 A</td> <td>int</td> <td>floor</td> <td>1504</td> <td></td> </tr> <tr> <td>2388-A 3 B</td> <td>↓</td> <td></td> <td></td> <td></td> </tr> <tr> <td>2388-A 3 C</td> <td></td> <td></td> <td></td> <td></td> </tr> </tbody> </table>												Sample ID	Room Sampled	Sample Location	PIC ID	Notes	2388-A 3 A	int	floor	1504		2388-A 3 B	↓				2388-A 3 C				
Sample ID	Room Sampled	Sample Location	PIC ID	Notes																											
2388-A 3 A	int	floor	1504																												
2388-A 3 B	↓																														
2388-A 3 C																															

# 321720066

**Hazardous Homogeneous Materials and Sampling Survey Field Form: Asbestos**

Project Number: 2388 3 Location: DOW Kekaha 0.5MG Storage Tank Inspector Initials: AI Survey Dates and Times: J.A.F

HM ID	Building	Flr.	Rooms	Locations	Material Color	Material	Substrate	Condition	Friable ACM Type	Area (Sq. ft. or L. ft.)	Hatch Color																				
8	0.5MG Tank	1	Int	Sealant Joint	Grey	Asphalt	CC	GFP	Y (N)	5000 4000	—																				
<table border="1"> <thead> <tr> <th>Sample ID</th> <th>Room Sampled</th> <th>Sample Location</th> <th>PIC ID</th> <th>Notes</th> </tr> </thead> <tbody> <tr> <td>2388-A4 A</td> <td>Int</td> <td>Sealant joint</td> <td>1501</td> <td></td> </tr> <tr> <td>2388-A4 B</td> <td>↓</td> <td>↓</td> <td></td> <td></td> </tr> <tr> <td>2388-A4 C</td> <td></td> <td></td> <td></td> <td></td> </tr> </tbody> </table>												Sample ID	Room Sampled	Sample Location	PIC ID	Notes	2388-A4 A	Int	Sealant joint	1501		2388-A4 B	↓	↓			2388-A4 C				
Sample ID	Room Sampled	Sample Location	PIC ID	Notes																											
2388-A4 A	Int	Sealant joint	1501																												
2388-A4 B	↓	↓																													
2388-A4 C																															
9	0.5MG Tank	1	Int	walls	Black	P/S - Coating	CC	GFP	Y (N)	10,000	—																				
<table border="1"> <thead> <tr> <th>Sample ID</th> <th>Room Sampled</th> <th>Sample Location</th> <th>PIC ID</th> <th>Notes</th> </tr> </thead> <tbody> <tr> <td>2388-A5 A</td> <td>Int</td> <td>walls</td> <td>1501</td> <td></td> </tr> <tr> <td>2388-A5 B</td> <td>↓</td> <td>↓</td> <td></td> <td></td> </tr> <tr> <td>2388-A5 C</td> <td></td> <td></td> <td></td> <td></td> </tr> </tbody> </table>												Sample ID	Room Sampled	Sample Location	PIC ID	Notes	2388-A5 A	Int	walls	1501		2388-A5 B	↓	↓			2388-A5 C				
Sample ID	Room Sampled	Sample Location	PIC ID	Notes																											
2388-A5 A	Int	walls	1501																												
2388-A5 B	↓	↓																													
2388-A5 C																															
10	0.5MG Tank	1	Ext	walls	AS	P/SC	CC	GFP	Y (N)	10,000	—																				
<table border="1"> <thead> <tr> <th>Sample ID</th> <th>Room Sampled</th> <th>Sample Location</th> <th>PIC ID</th> <th>Notes</th> </tr> </thead> <tbody> <tr> <td>2388-A6 A</td> <td>Ext</td> <td>walls</td> <td>1509</td> <td></td> </tr> <tr> <td>2388-A6 B</td> <td>↓</td> <td>↓</td> <td></td> <td></td> </tr> <tr> <td>2388-A6 C</td> <td></td> <td></td> <td></td> <td></td> </tr> </tbody> </table>												Sample ID	Room Sampled	Sample Location	PIC ID	Notes	2388-A6 A	Ext	walls	1509		2388-A6 B	↓	↓			2388-A6 C				
Sample ID	Room Sampled	Sample Location	PIC ID	Notes																											
2388-A6 A	Ext	walls	1509																												
2388-A6 B	↓	↓																													
2388-A6 C																															



# EMSL Analytical, Inc.

200 Route 130 North Cinnaminson, NJ 08077

Tel/Fax: (800) 220-3675 / (856) 786-5974

<http://www.EMSL.com> / [cinnasblab@EMSL.com](mailto:cinnasblab@EMSL.com)

EMSL Order: 041731009

Customer ID: 32MYOU50

Customer PO:

Project ID:

**Attention:** Akari Ihara  
Myounghee Noh & Associates, LLC  
99-1046 Iwaena Street  
Suite 210A  
Aiea, HI 96701

**Phone:** (808) 358-1421

**Fax:**

**Received Date:** 10/25/2017 4:30 PM

**Analysis Date:** 10/27/2017

**Collected Date:**

**Project:** 23883

## Test Report: Asbestos Analysis of Bulk Materials via EPA 600/R-93/116 Method using Polarized Light Microscopy

Sample	Description	Appearance	Non-Asbestos		Asbestos
			% Fibrous	% Non-Fibrous	% Type
2388-A7A <small>041731009-0001</small>	P2388-PCB4A	Brown/Black Non-Fibrous Homogeneous		100% Non-fibrous (Other)	None Detected
2388-A7B <small>041731009-0002</small>	P2388-PCB4B	Black Non-Fibrous Homogeneous		100% Non-fibrous (Other)	None Detected
2388-A7C <small>041731009-0003</small>	P2388-PCB4C	Black Non-Fibrous Homogeneous		100% Non-fibrous (Other)	None Detected

Analyst(s)

Steven Quinn (2)

Seri Smith (1)

Benjamin Ellis, Laboratory Manager  
or Other Approved Signatory

EMSL maintains liability limited to cost of analysis. This report relates only to the samples reported and may not be reproduced, except in full, without written approval by EMSL. EMSL bears no responsibility for sample collection activities or analytical method limitations. Interpretation and use of test results are the responsibility of the client. This report must not be used by the client to claim product certification, approval, or endorsement by NVLAP, NIST or any agency of the federal government. Non-friable organically bound materials present a problem matrix and therefore EMSL recommends gravimetric reduction prior to analysis. Samples received in good condition unless otherwise noted. Estimated accuracy, precision and uncertainty data available upon request. Unless requested by the client, building materials manufactured with multiple layers (i.e. linoleum, wallboard, etc.) are reported as a single sample. Reporting limit is 1%

Samples analyzed by EMSL Analytical, Inc. Cinnaminson, NJ NVLAP Lab Code 101048-0, AIHA-LAP, LLC-IHLAP Lab 100194, NYS ELAP 10872, NJ DEP 03036, PA ID# 68-00367

Initial report from: 10/27/2017 18:10:40



### Asbestos Chain of Custody

EMSL Order Number (Lab Use Only):

041731009

LATESTING  
5200 MISSION STREET  
SOUTH PASADENA, CA 91030  
CHINA TOWN  
PHONE: (800) 803-0047  
FAX: (323) 254-9962

2017 OCT 25 P 4:32

Company: Myounghee Noh & Associates L.L.C		EMSL-Bill to: <input type="checkbox"/> Same <input checked="" type="checkbox"/> Different If Bill to is Different note instructions in Comments**	
Street: 99-1046 Iwaena St.		Third Party Billing requires written authorization from third party	
City: Aiea	State/Province: Hawaii	Zip/Postal Code:	Country:
Report To (Name): AKARI		Telephone #:	
Email Address:		Fax #:	Purchase Order:
Project Name/Number: 2388-3		Please Provide Results: <input type="checkbox"/> Fax <input type="checkbox"/> Email <input type="checkbox"/> Mail	
U.S. State Samples Taken: HI		Connecticut Samples: <input type="checkbox"/> Commercial <input type="checkbox"/> Residential	

Turnaround Time (TAT) Options\* - Please Check

3 Hour  
  6 Hour  
  24 Hour  
  48 Hour  
  72 Hour  
  96 Hour  
  1 Week  
  2 Week

\*For TEM Air 3 hr through 6 hr, please call ahead to schedule. There is a premium charge for 3 Hour TEM AHERA or EPA Level II TAT. You will be asked to sign an authorization form for this service. Analysis completed in accordance with EMSL's Terms and Conditions located in the Analytical Price Guide.

<b>PCM - Air</b> <input type="checkbox"/> Check if samples are from NY <input type="checkbox"/> NIOSH 7400 <input type="checkbox"/> w/ OSHA 8hr. TWA <b>PLM - Bulk (reporting limit)</b> <input checked="" type="checkbox"/> PLM EPA 600/R-93/116 (<1%) <input type="checkbox"/> PLM EPA NOB (<1%) Point Count <input type="checkbox"/> 400 (<0.25%) <input type="checkbox"/> 1000 (<0.1%) Point Count w/Gravimetric <input type="checkbox"/> 400 (<0.25%) <input type="checkbox"/> 1000 (<0.1%) <input type="checkbox"/> NYS 198.1 (friable in NY) <input type="checkbox"/> NYS 198.6 NOB (non-friable-NY) <input type="checkbox"/> NIOSH 9002 (<1%)	<b>TEM - Air</b> <input type="checkbox"/> 4-4.5hr TAT (AHERA only) <input type="checkbox"/> AHERA 40 CFR, Part 763 <input type="checkbox"/> NIOSH 7402 <input type="checkbox"/> EPA Level II <input type="checkbox"/> ISO 10312 <b>TEM - Bulk</b> <input type="checkbox"/> TEM EPA NOB <input type="checkbox"/> NYS NOB 198.4 (non-friable-NY) <input type="checkbox"/> Chatfield SOP <input type="checkbox"/> TEM Mass Analysis-EPA 600 sec. 2.5 <b>TEM - Water: EPA 100.2</b> Fibers >10µm <input type="checkbox"/> Waste <input type="checkbox"/> Drinking All Fiber Sizes <input type="checkbox"/> Waste <input type="checkbox"/> Drinking	<b>TEM- Dust</b> <input type="checkbox"/> Microvac - ASTM D 5755 <input type="checkbox"/> Wipe - ASTM D6480 <input type="checkbox"/> Carpet Sonication (EPA 600/J-93/167) <b>Soil/Rock/Vermiculite</b> <input type="checkbox"/> PLM CARB 435 - A (0.25% sensitivity) <input type="checkbox"/> PLM CARB 435 - B (0.1% sensitivity) <input type="checkbox"/> TEM CARB 435 - B (0.1% sensitivity) <input type="checkbox"/> TEM CARB 435 - C (0.01% sensitivity) <input type="checkbox"/> TEM Qual. via Filtration Technique <input type="checkbox"/> TEM Qual. via Drop-Mount Technique <b>Other:</b> <input type="checkbox"/>
---	--	---

Check For Positive Stop - Clearly Identify Homogenous Group    Filter Pore Size (Air Samples):  0.8µm  0.45µm

Samplers Name: \_\_\_\_\_ Samplers Signature: *AKARI*

Sample #	Sample Description	Volume/Area (Air) HA # (Bulk)	Date/Time Sampled
2388- A7A	Use PCB samples (P2388-PCB4A)		
↓ ↓ B	↓ ↓ ↓ B		
↓ ↓ C	↓ ↓ ↓ C		

Client Sample # (s): 2388- A7A, B, C    Total # of Samples: 3

Relinquished (Client): *AKARI*    Date: 10-23-17    Time: \_\_\_\_\_

Received (Lab): *W*    Date: 10-25-17    Time: 11:30am

Comments/Special Instructions: \_\_\_\_\_

#321720066

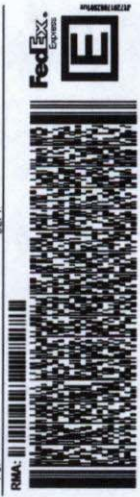
2

ORIGINATOR NAME: (000) 484-9214  
POLYMER CHEMICAL ASSOCIATES, LLC  
66-1040 IRVINE STREET SUITE 210A  
IRVINE, CA 92614  
UNITED STATES US

SHIP DATE: 18AUG17  
CXL: 10220858UWSX02000

TO SAMPLE RECEIVING  
LA TESTING  
520 MISSION STREET

SOUTH PASADENA CA 91030  
REF: AR, MEDIA, RFA, ZGM01050



RETURNS MON-FRI  
PRIORITY OVERNIGHT

7953 2369 9011

91030

CA-US



IMPORTANT! Do not duplicate this label. Each package must contain a unique tracking number in order to maintain tracking and billing integrity.  
Use of this FedEx shipping label is subject to the following restrictions and conditions:

Disclaimer

- The shipment must be via FedEx packaging (FedEx envelope pack or FedEx box); this label is not valid for use on non-standard packages nor coolers.
- Valid for shipment of the following samples only: Lead analysis of paint chips, air samples, or wipe samples; asbestos testing of bulk material samples, wipe/dust samples, or air sample cassettes; Microbiology air samples or bulk samples; tape lift samples; and/or swab samples. This label and shipping is not valid for shipment of any sample that requires a cooler or any other sample type not specifically described herein.
- The package shipment must exceed a minimum of \$100 in analytical fees. If this minimum is not met, a minimum shipping fee of \$15 will be added to the analysis invoice.
- Not valid for the shipping of any hazardous materials or items prohibited to be shipped by these means.
- Valid for only those accounts pre-approved to use this service. This courtesy shipping service may be terminated at any time by LA Testing for any customer accounts that are not in good standing due to late payment (COD Status, or any other reason in the sole determination of LA Testing).
- Any additional fees, including, but not limited to, custom pickup fees from FedEx, excessive weight fees, and any surcharge items added by FedEx, associated with this label/package will be back-charged to the customer that made the shipment.
- This label is not valid for weekend or holiday deliveries.
- Excludes Summa Centers, Equipment Rental and Loaner Returns.
- Valid in the Continental United States and within Canada.



# LA Testing

520 Mission Street South Pasadena, CA 91030  
Phone/Fax: (323) 254-9960 / (323) 254-9982  
<http://www.LATesting.com> / [pasadenalab@lateesting.com](mailto:pasadenalab@lateesting.com)

LA Testing Order: 321720371  
Customer ID: 32MYOU50  
Customer PO:  
Project ID:

**Attention:** Akari Ihara  
Myounghee Noh & Associates, LLC  
99-1046 Iwaena Street  
Suite 210A  
Aiea, HI 96701  
**Project:** Re-analysis 321720066 / 2388.3

**Phone:** (808) 358-1421  
**Fax:**  
**Received:** 08/25/2017 4:38 PM  
**Analysis Date:** 08/29/2017  
**Collected:**

## Test Report: Asbestos Analysis of Bulk Materials via EPA 600/R-93/116 Method using Polarized Light Microscopy. Quantitation using 400 Point Count Procedure

Sample	Description	Appearance	Non-Asbestos		Asbestos
			% Fibrous	% Non-Fibrous	% Type
2388.A3A-2388.A3 A-Cementitious Material 321720371-0001	Lut Floor - Beige	Brown/Gray Non-Fibrous Homogeneous		100% Non-fibrous (Other)	<0.25% Chrysotile
2388.A3B-2388.A3 A-Cementitious Material 321720371-0002	Lut Floor - Beige	Gray Non-Fibrous Homogeneous		100% Non-fibrous (Other)	<0.25% Chrysotile

Analyst(s)

Kieu-anh Pham Duong (2)

Jerry Drapala Ph.D, Laboratory Manager  
or other approved signatory

Disclaimer: Some samples may contain asbestos fibers present in dimensions below PLM resolution limits. The limit of detection as stated in the method is 0.25%. EMSL Analytical Inc suggests that samples reported as <0.25% or none detected undergo additional analysis via TEM. The above test report relates only to the items tested. This report may not be reproduced, except in full, without written approval of EMSL Analytical Inc. This test report must not be used by the client to claim product endorsement by NVLAP or any agency of the United States Government. EMSL Analytical Inc., bears no responsibility for sample collection activities, analytical method limitations, or the accuracy of results when requested to separate layered samples. EMSL Analytical Inc., liability is limited to the cost of sample analysis. The test results contained within this report meet the requirements of NELAC unless otherwise noted. Samples received in good condition unless otherwise noted. Unless requested by the client, building materials manufactured with multiple layers (i.e. linoleum, wallboard, etc.) are reported as a single sample.

Samples analyzed by LA Testing South Pasadena, CA NVLAP Lab Code 200232-0

Initial report from: 08/29/2017 16:04:15

**Mulcahy, Brandon**

---

**From:** Akari Ihara <akari@noh-associates.com>  
**Sent:** Friday, August 25, 2017 4:38 PM  
**To:** Vong, Julie; LA Testing Lab - Pasadena  
**Subject:** RE: LA Testing report, COC for order(s) 321720066 (321720066 - 2388.3)

Aloha,  
Can we get a 400 point count on the 2388.A3A,B,C (<1%). With a three day TAT.

Thank you,

**From:** LA Testing (South Pasadena) [mailto:pasadenalab@latestesting.com]  
**Sent:** Friday, August 25, 2017 11:34 AM  
**To:** Akari Ihara <akari@noh-associates.com>  
**Subject:** LA Testing report, COC for order(s) 321720066 (321720066 - 2388.3)

Report, COC for order(s):  
321720066 - 2388.3



**Julie Vong** | *Laboratory Analyst*

**LA Testing** | 520 Mission Street | South Pasadena, CA 91030  
Phone: 323-254-9960 | Fax: 323-254-9982 | Toll Free: 800-303-0047  
Lab Hours: Monday - Friday 8AM - 6PM, Saturday 9AM - 5PM, Sunday On-Call

Some of the resources LATesting, Inc. offers to our clients:  
[LABConnect](#) | [Order Products](#) | [Client Corner](#) | [Training](#) | [Additional Resources](#) | [Sampling Videos](#)

---

"This email may contain privileged and confidential information and is solely for the use of the sender's intended recipient(s). **If you are not the intended recipient of this communication, you are hereby notified that any unauthorized review, use, dissemination, distribution, downloading, or copying of this communication is strictly prohibited.** If you received this email in error, please notify the sender by reply email and delete all copies and attachments. Thank you."





## LA Testing

520 Mission Street South Pasadena, CA 91030

Tel/Fax: (323) 254-9960 / (323) 254-9982

http://www.LATesting.com / pasadenalab@lateesting.com

LA Testing Order: 321720066

Customer ID: 32MYOU50

Customer PO:

Project ID:

**Attention:** Akari Ihara  
 Myounghee Noh & Associates, LLC  
 99-1046 Iwaena Street  
 Suite 210A  
 Aiea, HI 96701

Project: 2388.3

Phone: (808) 358-1421

Fax:

Received Date: 08/21/2017 9:20 AM

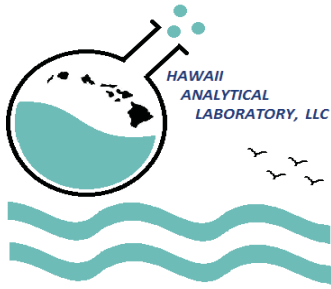
Analysis Date: 08/25/2017

Collected Date:

### Test Report: Asbestos Analysis of Bulk Materials via EPA 600/R-93/116 Method using Polarized Light Microscopy

Sample	Description	Appearance	Non-Asbestos		Asbestos
			% Fibrous	% Non-Fibrous	% Type
2388.A1A <small>321720066-0001</small>	Ext Roof System - P/SC	Gray Non-Fibrous Homogeneous		100% Non-fibrous (Other)	None Detected
2388.A1B <small>321720066-0002</small>	Ext Roof System - P/SC	Green Non-Fibrous Homogeneous		100% Non-fibrous (Other)	None Detected
2388.A1C <small>321720066-0003</small>	Ext Roof System - P/SC	Green/Beige Non-Fibrous Homogeneous		100% Non-fibrous (Other)	None Detected
2388.A2A <small>321720066-0004</small>	Ext Vent - Gray cementitas	Gray Non-Fibrous Homogeneous		100% Non-fibrous (Other)	None Detected
2388.A2B <small>321720066-0005</small>	Ext Vent - Gray cementitas	Gray Non-Fibrous Homogeneous		100% Non-fibrous (Other)	None Detected
2388.A2C <small>321720066-0006</small>	Ext Vent - Gray cementitas	Gray Non-Fibrous Homogeneous		100% Non-fibrous (Other)	None Detected
2388.A3A-Coating <small>321720066-0007</small>	Lut Floor - beige coating	Beige/Orange Non-Fibrous Homogeneous		100% Non-fibrous (Other)	None Detected
2388.A3A-Cementitious Material <small>321720066-0007A</small>	Lut Floor - beige coating	Brown/Gray Non-Fibrous Homogeneous		100% Non-fibrous (Other)	<1% Chrysotile
2388.A3B-Coating <small>321720066-0008</small>	Lut Floor - beige coating	Beige/Orange Non-Fibrous Homogeneous		100% Non-fibrous (Other)	None Detected
2388.A3B-Cementitious Material <small>321720066-0008A</small>	Lut Floor - beige coating	Gray Non-Fibrous Homogeneous		100% Non-fibrous (Other)	<1% Chrysotile
2388.A3C <small>321720066-0009</small>	Lut Floor - beige coating	Beige/Orange Non-Fibrous Homogeneous		100% Non-fibrous (Other)	None Detected
2388.A4A-Coating <small>321720066-0010</small>	Lut Sealant Joint - beige asphalt base sealant	Orange Non-Fibrous Homogeneous		100% Non-fibrous (Other)	None Detected
2388.A4A-Texture <small>321720066-0010A</small>	Lut Sealant Joint - beige asphalt base sealant	Gray Non-Fibrous Homogeneous		100% Non-fibrous (Other)	None Detected
2388.A4A-Tar <small>321720066-0010B</small>	Lut Sealant Joint - beige asphalt base sealant	Black Non-Fibrous Homogeneous		100% Non-fibrous (Other)	None Detected
2388.A4B-Coating <small>321720066-0011</small>	Lut Sealant Joint - beige asphalt base sealant	Orange Non-Fibrous Homogeneous		100% Non-fibrous (Other)	None Detected

Initial report from: 08/25/2017 14:24:05



# Hawaii Analytical Laboratory ANALYTICAL REPORT

Friday, August 25, 2017

Ms. Myounghee Noh  
 Myounghee Noh & Associates  
 99-1046 Iwaena St. Suite 210A  
 Aiea HI 96701

**Phone Number:** (808) 484-9214  
**Facsimile:** (808) 484-4660  
**Email:** m\_noh@noh-associates.com

**Lab Job No:** 20176765  
**Date Submitted:** 8/18/2017  
**Your Project:** DOW Kekaha 0.5 MG Tank, 8/17/2017

## Lead, total (paint chips)

NIOSH Method: 7082m LEAD by FAAS

Sample No.	Your Sample Description	Results	Units	Date Analyzed
201737463	2388-P1A	1200	mg/kg	8/23/2017
Comments				
201737464	2388-P1B	710	mg/kg	8/23/2017
Comments				
201737465	2388-P2A	55000	mg/kg	8/23/2017
Comments				
201737466	2388-P2B	41000	mg/kg	8/23/2017
Comments				
201737467	2388-P3A	1400	mg/kg	8/23/2017
Comments				
201737468	2388-P3B	1200	mg/kg	8/23/2017
Comments				
201737469	2388-P4A	41000	mg/kg	8/23/2017
Comments				
201737470	2388-P4B	40000	mg/kg	8/23/2017
Comments				

Hawaii Analytical Laboratory (101812) is accredited by the AIHA LAP, LLC in the EMLAP, IHLAP, and ELLAP programs for the scope of work listed on [www.aihaaccreditedlabs.org](http://www.aihaaccreditedlabs.org), in accordance with the recognized ISO/ IEC 17025:2005.  
 Controlled doc.: Lead Report, rev. 3 - 20161017

Ms. Myounghee Noh  
Myounghee Noh & Associates  
99-1046 Iwaena St. Suite 210A  
Aiea HI 96701

**Phone Number:** (808) 484-9214  
**Facsimile:** (808) 484-4660  
**Email:** m\_noh@noh-associates.com

**Lab Job No:** 20176765  
**Date Submitted:** 8/18/2017  
**Your Project:** DOW Kekaha 0.5 MG Tank, 8/17/2017

### Lead, total (paint chips)

NIOSH Method: 7082m LEAD by FAAS

Sample No.	Your Sample Description	Results	Units	Date Analyzed
201737471	2388-P5A	< 40	mg/kg	8/23/2017
Comments				
201737472	2388-P5B	< 40	mg/kg	8/23/2017
Comments				
201737473	2388-P6A	< 40	mg/kg	8/23/2017
Comments				
201737474	2388-P6B	< 40	mg/kg	8/23/2017
Comments				

All Quality Control data are acceptable unless otherwise noted.

MRL for lead air is 5ug.

MRL for lead wipe is 10ug.

MRL for lead paint or soil is 40 mg/kg for a 0.25g sample.

#### General Comments

The sample[s] analysis subject of this analytical report were conducted in general accordance with the procedures associated with the "analytical method" referenced above. Modifications to this methodology may have been made based upon the analyst's professional judgment and / or sample matrix effects encountered. The analysis of sample relates only to the sample analyzed, and may or may not be representative of the original source of the material submitted for our analysis. All analysts participate in interlaboratory quality control testing to continuously document proficiency. This report is not to be duplicated except in full without the expressed written permission of Hawaii Analytical Laboratory. This report should not be construed as an endorsement for a product or a service by the AIHA LAP, LLC or any affiliated organizations. Sample and associated sampling / collection data is reported as provided by client. TWA values have been calculated based on information supplied by the client that the laboratory has not independently verified. Results have not been corrected for blank determinations unless noted in remarks. Unless otherwise indicated the sample condition at the time of receipt was acceptable.

#### Results and Symbols Definitions

> This testing result is greater than the numerical value listed.

< This testing result is less than the numerical value listed.

# = Analytical methods marked with an "#" are not within our AIHA LAP, LLC Scope of Accreditation.

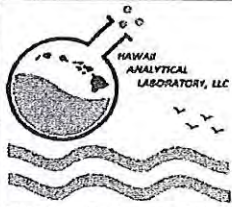
MRL = Method Reporting Limit.



**Jennifer Hsu Liao**  
**Laboratory Manager**

Hawaii Analytical Laboratory (101812) is accredited by the AIHA LAP, LLC in the EMLAP, IHLAP, and ELLAP programs for the scope of work listed on [www.aihaaccreditedlabs.org](http://www.aihaaccreditedlabs.org), in accordance with the recognized ISO/ IEC 17025:2005.

Controlled doc.: Lead Report, rev. 3 - 20161017



3615 Harding Avenue, Suite 308  
 Honolulu, HI 96816  
 PH: 808-735-0422  
 FAX: 808-735-0047

**Need Results By\*:**

- 5 Working Days
- 4 Working Days
- 72 hour
- 48 hour
- 24 Hour
- Rush - 6 hours
- Immediate - 4 hrs or less

New Client?

Report To\* : Myounghee Noh  
 Company : Myounghee Noh & Associates, LLC  
 Address\* : 99-1046 Iwaena Street, 210A  
 Aiea, HI 96701  
 Phone / Cell No.\* : 808-484-9214  
 Report results to :  
 via email or fax :  
 or verbal :

Invoice To\* : Myounghee Noh & Associates, LLC  
 Company :  
 Address\* : 99-1046 Iwaena Street, 210A  
 Aiea, HI 96701  
 Phone / Cell No.\* : 808-484-9214  
 Purchase Order No. :  
 Email Invoice To :

Site/Project Name: DOW Kekaha 0.5 MG Tank Client Project No.: 2388.2 Sampled By: AI

Comments / Special Instructions:

PLM POSITIVE STOP Instructions:

- Positive stop per SAMPLE
- Positive stop per LAYER

**LAB USE ONLY**

Lab Report No.:  
**20176765**

Sample Identification* (Maximum of 30 Characters)	Date Sampled* (mm/dd/yy)	Collection Medium	Sample Area / Air Volume	Analysis Requested*	Method Reference	Lab ID
<u>2388-PIA</u> <u>L ↓ B</u>	<u>8.17.17</u>	<u>PoChrp</u>	<u>NA</u>	<u>PoChrp</u>		
<u>2388-P6A</u> <u>L ↓ B</u>						

Relinquished By (Print and Sign) 	Date/Time <u>1 8.18.17</u>	Received By (Print and Sign) <u>Anne Antin</u>	Date/Time <u>08-18-17P01:44 RCVD</u>
--------------------------------------	-------------------------------	---	---

Sample description can be paint chips, concrete, specific sample collection location, etc...  
 If matrix is 'soil', please specify if it is a FOREIGN SOIL SAMPLE (outside Hawaii) in the comment section.  
 All samples submitted are subject to Hawaii Analytical Laboratory terms and conditions.  
 \*Required fields, failure to complete these fields may result in a delay in your samples being processed.  
 Rev 20140701

### Hazardous Homogeneous Materials and Sampling Survey Field Form: Lead Paint

6765

Project Number: 2388 3 Location: DOW Kekaha 0.5MG Storage Tank

Inspector Initials: AI Survey Dates and Times: 8.17.17

HM ID	Building	Flr.	Rooms	Locations	Material Color	Material	Substrate	Condition	Area Sq. ft or L. ft	Hatch Color
1	0.5MG Res Tank	R	ext	Roofing System	lt blue	P	CC	GⓅP	2,000 700	
Sample ID		Room Sampled		Sample Location		PIC ID		Notes		
2388-P 1 A		ext 201737463		Roofing system		1489				
2388-P 1 B		↓ 201737464		↓						
HM ID	Building	Flr.	Rooms	Locations	Material Color	Material	Substrate	Condition	Area Sq. ft or L. ft	Hatch Color
2 4	0.5MG Tank	R	ext	Hatch	Drk Green	P	M	GⓅP	5	
Sample ID		Room Sampled		Sample Location		PIC ID		Notes		
2388-P 2 A		ext 201737465		Hatch		1492				
2388-P 2 B		↓ 201737466		↓						
HM ID	Building	Flr.	Rooms	Locations	Material Color	Material	Substrate	Condition	Area Sq. ft or L. ft	Hatch Color
5	0.5MG Tank	R	BA	handrail, ladder	lt green	P	M	GⓅP	20	
Sample ID		Room Sampled		Sample Location		PIC ID		Notes		
2388-P 3 A		ext 201737467		handrail		1495				
2388-P 3 B		↓ 201737468		ladder						

**Hazardous Homogeneous Materials and Sampling Survey Field Form: Lead Paint**

Project Number: 2388 3 Location: DOW Kekaha 0.5MG Storage Tank

Inspector Initials: AI

Survey Dates and Times: 8.17.17

HM ID	Building	Flr.	Rooms	Locations	Material Color	Material	Substrate	Condition	Area Sq. ft or L. ft	Hatch Color
6	0.5MG Tank	1	Int	Floor	beige	coating	CC	G F P	5,000	Same as HM7
Sample ID		Room Sampled		Sample Location		PIC ID	Notes			
2388-P 4 A		Int 201737469		floor		1501				
2388-P 4 B		↓ 201737470		↓						
HM ID	Building	Flr.	Rooms	Locations	Material Color	Material	Substrate	Condition	Area Sq. ft or L. ft	Hatch Color
10		1	Ext	walls	gray	P	CC	G F P	10,000	Same as HM10
Sample ID		Room Sampled		Sample Location		PIC ID	Notes			
2388-P 5 A		Ext 201737471		walls		1509				
2388-P 5 B		↓ 201737472		↓						
HM ID	Building	Flr.	Rooms	Locations	Material Color	Material	Substrate	Condition	Area Sq. ft or L. ft	Hatch Color
11		1	Ext	walls	beige	P	CC	G F P	5,000	
Sample ID		Room Sampled		Sample Location		PIC ID	Notes			
2388-P 6 A		Ext 201737473		Walls		1509				
2388-P 6 B		↓ 201737474		↓						



**EMSL Analytical, Inc.**

200 Route 130 North, Cinnaminson, NJ 08077

Phone: (856) 303-2500 Fax: (856) 858-4571 Email: EnvChemistry2@emsl.com

---

Attn:

**Akari Ihara**  
**Myounghee Noh & Associates, LLC**  
**99-1046 Iwaena Street**  
**Suite 210A**  
**Aiea, HI 96701**

9/11/2017

Phone: (808) 484-9214

Fax:

The following analytical report covers the analysis performed on samples submitted to EMSL Analytical, Inc. on 8/23/2017. The results are tabulated on the attached data pages for the following client designated project:

**2388.3**

The reference number for these samples is EMSL Order #011706838. Please use this reference when calling about these samples. If you have any questions, please do not hesitate to contact me at (856) 303-2500.

Approved By:

---

Phillip Worby, Environmental Chemistry  
Laboratory Director



The test results contained within this report meet the requirements of NELAP and/or the specific certification program that is applicable, unless otherwise noted.  
NELAP Certifications: NJ 03036, NY 10872, PA 68-00367, CA ELAP 1877

The samples associated with this report were received in good condition unless otherwise noted. This report relates only to those items tested as received by the laboratory. The QC data associated with the sample results meet the recovery and precision requirements established by the NELAP, unless specifically indicated. All results for soil samples are reported on a dry weight basis, unless otherwise noted. This report may not be reproduced except in full and without written approval by EMSL Analytical, Inc.

**EMSL Analytical, Inc.**

200 Route 130 North, Cinnaminson, NJ 08077

Phone/Fax: (856) 303-2500 / (856) 858-4571

<http://www.EMSL.com>[EnvChemistry2@emsl.com](mailto:EnvChemistry2@emsl.com)

EMSL Order: 011706838

CustomerID: 32MYOU50

CustomerPO:

ProjectID:

Attn: **Akari Ihara**  
**Myounghee Noh & Associates, LLC**  
**99-1046 Iwaena Street**  
**Suite 210A**  
**Aiea, HI 96701**

Phone: (808) 484-9214

Fax:

Received: 08/23/17 9:15 AM

Project: 2388.3

**Analytical Results**

**Client Sample Description** 2388.PCB1-A,B,C **Collected:** 8/18/2017 **Lab ID:** 011706838-0001

Method	Parameter	Result	RL	Units	Prep Date	Analyst	Analysis Date	Analyst
3540C/8082A	Aroclor-1016	ND	0.79	mg/Kg	9/7/2017	AB	9/11/2017	EH
3540C/8082A	Aroclor-1221	ND	0.79	mg/Kg	9/7/2017	AB	9/11/2017	EH
3540C/8082A	Aroclor-1232	ND	0.79	mg/Kg	9/7/2017	AB	9/11/2017	EH
3540C/8082A	Aroclor-1242	2.3	0.79	mg/Kg	9/7/2017	AB	9/11/2017	EH
3540C/8082A	Aroclor-1248	ND	0.79	mg/Kg	9/7/2017	AB	9/11/2017	EH
3540C/8082A	Aroclor-1254	8.1	0.79	mg/Kg	9/7/2017	AB	9/11/2017	EH
3540C/8082A	Aroclor-1260	18	0.79	mg/Kg	9/7/2017	AB	9/11/2017	EH
3540C/8082A	Aroclor-1262	ND	0.79	mg/Kg	9/7/2017	AB	9/11/2017	EH
3540C/8082A	Aroclor-1268	ND	0.79	mg/Kg	9/7/2017	AB	9/11/2017	EH

**Client Sample Description** 2388.PCB2-A,B,C **Collected:** 8/18/2017 **Lab ID:** 011706838-0002

Method	Parameter	Result	RL	Units	Prep Date	Analyst	Analysis Date	Analyst
3540C/8082A	Aroclor-1016	ND	0.82	mg/Kg	9/7/2017	AB	9/8/2017	EH
3540C/8082A	Aroclor-1221	ND	0.82	mg/Kg	9/7/2017	AB	9/8/2017	EH
3540C/8082A	Aroclor-1232	ND	0.82	mg/Kg	9/7/2017	AB	9/8/2017	EH
3540C/8082A	Aroclor-1242	2.4	0.82	mg/Kg	9/7/2017	AB	9/8/2017	EH
3540C/8082A	Aroclor-1248	ND	0.82	mg/Kg	9/7/2017	AB	9/8/2017	EH
3540C/8082A	Aroclor-1254	3.4	0.82	mg/Kg	9/7/2017	AB	9/8/2017	EH
3540C/8082A	Aroclor-1260	4.7	0.82	mg/Kg	9/7/2017	AB	9/8/2017	EH
3540C/8082A	Aroclor-1262	ND	0.82	mg/Kg	9/7/2017	AB	9/8/2017	EH
3540C/8082A	Aroclor-1268	ND	0.82	mg/Kg	9/7/2017	AB	9/8/2017	EH

**Client Sample Description** 2388.PCB3-A,B,C **Collected:** 8/18/2017 **Lab ID:** 011706838-0003

Method	Parameter	Result	RL	Units	Prep Date	Analyst	Analysis Date	Analyst
3540C/8082A	Aroclor-1016	ND	4.7	mg/Kg	9/7/2017	AB	9/11/2017	EH
3540C/8082A	Aroclor-1221	ND	4.7	mg/Kg	9/7/2017	AB	9/11/2017	EH
3540C/8082A	Aroclor-1232	ND	4.7	mg/Kg	9/7/2017	AB	9/11/2017	EH
3540C/8082A	Aroclor-1242	ND	4.7	mg/Kg	9/7/2017	AB	9/11/2017	EH
3540C/8082A	Aroclor-1248	ND	4.7	mg/Kg	9/7/2017	AB	9/11/2017	EH
3540C/8082A	Aroclor-1254	38	4.7	mg/Kg	9/7/2017	AB	9/11/2017	EH
3540C/8082A	Aroclor-1260	76	4.7	mg/Kg	9/7/2017	AB	9/11/2017	EH
3540C/8082A	Aroclor-1262	ND	4.7	mg/Kg	9/7/2017	AB	9/11/2017	EH
3540C/8082A	Aroclor-1268	ND	4.7	mg/Kg	9/7/2017	AB	9/11/2017	EH





## EMSL Analytical, Inc.

200 Route 130 North, Cinnaminson, NJ 08077

Phone/Fax: (856) 303-2500 / (856) 858-4571

<http://www.EMSL.com>

[EnvChemistry2@emsl.com](mailto:EnvChemistry2@emsl.com)

EMSL Order:	011706838
CustomerID:	32MYOU50
CustomerPO:	
ProjectID:	

### Definitions:

ND - indicates that the analyte was not detected at the reporting limit

RL - Reporting Limit (Analytical)



**Asbestos Chain of Custody**  
**EMSL Order Number (Lab Use Only):**

011706838

LATESTING  
 520 MISSION STREET  
 SOUTH PASADENA, CA 91030  
 PHONE: (800)-303-0047  
 FAX: (323)-254-9962

<b>Company :</b> Myounghee Noh & Associates L.L.C		<b>EMSL-Bill to:</b> <input type="checkbox"/> Same <input type="checkbox"/> Different If Bill to is Different note instructions in Comments**	
<b>Street:</b> 99-1046 Iwaena St.		Third Party Billing requires written authorization from third party	
<b>City:</b> Aiea	<b>State/Province:</b> Hawaii	<b>Zip/Postal Code:</b>	<b>Country:</b>
<b>Report To (Name):</b> Akari		<b>Telephone #:</b>	
<b>Email Address:</b>		<b>Fax #:</b>	<b>Purchase Order:</b>
<b>Project Name/Number:</b> 2388-3		<b>Please Provide Results:</b> <input type="checkbox"/> Fax <input type="checkbox"/> Email <input type="checkbox"/> Mail	
<b>U.S. State Samples Taken:</b> 4		<b>Connecticut Samples:</b> <input type="checkbox"/> Commercial <input type="checkbox"/> Residential	

**Turnaround Time (TAT) Options\* - Please Check**

3 Hour  
  6 Hour  
  24 Hour  
  48 Hour  
  72 Hour  
  96 Hour  
 1 Week  
 2 Week

\*For TEM Air 3 hr through 6 hr, please call ahead to schedule. \*There is a premium charge for 3 Hour TEM AHERA or EPA Level II TAT. You will be asked to sign an authorization form for this service. Analysis completed in accordance with EMSL's Terms and Conditions located in the Analytical Price Guide.

<b>PCM - Air</b> <input type="checkbox"/> Check if samples are from NY <input type="checkbox"/> NIOSH 7400 <input type="checkbox"/> w/ OSHA 8hr. TWA	<b>TEM - Air</b> <input type="checkbox"/> 4-4.5hr TAT (AHERA only) <input type="checkbox"/> AHERA 40 CFR, Part 763 <input type="checkbox"/> NIOSH 7402 <input type="checkbox"/> EPA Level II <input type="checkbox"/> ISO 10312	<b>TEM - Dust</b> <input type="checkbox"/> Microvac - ASTM D 5755 <input type="checkbox"/> Wipe - ASTM D6480 <input type="checkbox"/> Carpet Sonication (EPA 600/J-93/167)
<b>PLM - Bulk (reporting limit)</b> <input type="checkbox"/> PLM EPA 600/R-93/116 (<1%) <input type="checkbox"/> PLM EPA NOB (<1%) Point Count <input type="checkbox"/> 400 (<0.25%) <input type="checkbox"/> 1000 (<0.1%) Point Count w/Gravimetric <input type="checkbox"/> 400 (<0.25%) <input type="checkbox"/> 1000 (<0.1%) <input type="checkbox"/> NYS 198.1 (friable in NY) <input type="checkbox"/> NYS 198.6 NOB (non-friable-NY) <input type="checkbox"/> NIOSH 9002 (<1%)	<b>TEM - Bulk</b> <input type="checkbox"/> TEM EPA NOB <input type="checkbox"/> NYS NOB 198.4 (non-friable-NY) <input type="checkbox"/> Chatfield SOP <input type="checkbox"/> TEM Mass Analysis-EPA 600 sec. 2.5	<b>Soil/Rock/Vermiculite</b> <input type="checkbox"/> PLM CARB 435 - A (0.25% sensitivity) <input type="checkbox"/> PLM CARB 435 - B (0.1% sensitivity) <input type="checkbox"/> TEM CARB 435 - B (0.1% sensitivity) <input type="checkbox"/> TEM CARB 435 - C (0.01% sensitivity) <input type="checkbox"/> TEM Qual. via Filtration Technique <input type="checkbox"/> TEM Qual. via Drop-Mount Technique
<input type="checkbox"/> Check For Positive Stop - Clearly Identify Homogenous Group		<b>Filter Pore Size (Air Samples):</b> <input type="checkbox"/> 0.8µm <input type="checkbox"/> 0.45µm

**Samplers Name:** Akari      **Samplers Signature:** [Signature]

Comp or separate?  
 (1)  
 (2)  
 (3)

Sample #	Sample Description	Volume/Area (Air) HA # (Bulk)	Date/Time Sampled
2388-PCB1A ↓ ↓ ↓ C	Bulk		
2388-PCB3A ↓ ↓ ↓ B C			

**Client Sample # (s):** 2388-PCB1A ~ 2388-PCB3C      **Total # of Samples:** 6

**Relinquished (Client):** [Signature]      **Date:** 8-18-17      **Time:**

**Received (Lab):** DF Lores (EMSL FedEx)      **Date:** 8/21/17      **Time:** 9:20am

**Comments/Special Instructions:**  
 Rec: FE (pv) 8.22.17 Relinquished: [Signature] 8.22.17

1300

Ca 21.7 8/23/17

09:15

\*Pasadena Lab sent corresponding samples to supplement for composite analysis on 9/6

\*After Akari: proceed w/ samples as composite at 3 day TAT on 9/6 14:30

011706838

Hazardous Homogeneous Materials and Sampling Survey Field Form: PCB Bulk

6.17.17

Project Number: 2388 3 Location: DOW Kekaha 0.5MG Storage Tank Inspector Initials: AI Survey Dates and Times:

Order ID: 011706838

HM ID	Building	Flr.	Rooms	Locations	Material Color	Material	Substrate	Condition	Friable ACM	Area Sq. ft or L. ft	Hatch Color
									Type		
12	0.5MG Tank	1	Int	floor + dibris	Beige	Asphalt base sealant	cc	G F P	Y (M) TSI S (M)	1,000	Same as HMG

Sample ID	Room Sampled	Sample Location	PIC ID	Notes
2388-PCB 1 A	Int	floor + dibris	1501	
2388-PCB 1 B	↓	↓	↓	
2388-PCB 1 C				

HM ID	Building	Flr.	Rooms	Locations	Material Color	Material	Substrate	Condition	Friable ACM	Area Sq. ft or L. ft	Hatch Color
									Type		
13	0.5MG Tank	1	Int	sealant joint	Beige	Asphalt base sealant	cc	G F P	Y (M) TSI S (M)	1,000	Same HMG

Sample ID	Room Sampled	Sample Location	PIC ID	Notes
2388-PCB 2 A			1501	
2388-PCB 2 B				
2388-PCB 2 C				

HM ID	Building	Flr.	Rooms	Locations	Material Color	Material	Substrate	Condition	Friable ACM	Area Sq. ft or L. ft	Hatch Color
									Type		
14	0.5MG Tank	1	Int - Int	walls	Blk	Coating	cc	G F P	Y (M) TSI S (M)	10,000	Same as HMG

Sample ID	Room Sampled	Sample Location	PIC ID	Notes
2388-PCB 3 A	Int	walls	1501	
2388-PCB 3 B				
2388-PCB 3 C				

Page 2 of 3

011706838

**Hazardous Homogeneous Materials and Sampling Survey Field Form: PCB Bulk**

Project Number: 2388 3 Location: DOW Kekaha 0.5MG Storage Tank Inspector Initials: AI Survey Dates and Times: 6.17.17

Order ID: 011706838

HM ID	Building	Flr.	Rooms	Locations	Material Color	Material	Substrate	Condition	Friable ACM	Area Sq. ft or L. ft	Hatch Color
									Type		
12	0.5MG Tank	1	Int	Floor + debris Sealant	Beige	Asphalt Asphalt	CC	G F P	Y (M) TSI S (M)	1,000	Same as HMG

Sample ID	Room Sampled	Sample Location	PIC ID	Notes
2388-PCB 1 A	Int	floor + debris	1501	
2388-PCB 1 B	↓	↓	↓	
2388-PCB 1 C				

HM ID	Building	Flr.	Rooms	Locations	Material Color	Material	Substrate	Condition	Friable ACM	Area Sq. ft or L. ft	Hatch Color
									Type		
13	0.5MG Tank	1	Int	Sealant joint	Beige	Asphalt beige sealant	CC	G F P	Y (M) TSI S (M)	1,000	Same HMG

Sample ID	Room Sampled	Sample Location	PIC ID	Notes
2388-PCB 2 A			1501	
2388-PCB 2 B				
2388-PCB 2 C				

HM ID	Building	Flr.	Rooms	Locations	Material Color	Material	Substrate	Condition	Friable ACM	Area Sq. ft or L. ft	Hatch Color
									Type		
14	0.5MG Tank	1	Int - Int	walls	Blk	Coating	CC	G F P	Y (M) TSI S (M)	10,000	Same as HMG

Sample ID	Room Sampled	Sample Location	PIC ID	Notes
2388-PCB 3 A	Int	walls	1501	
2388-PCB 3 B				
2388-PCB 3 C				

Page 3 of 3



**EMSL Analytical, Inc.**

200 Route 130 North, Cinnaminson, NJ 08077

Phone: (856) 303-2500 Fax: (856) 858-4571 Email: EnvChemistry2@emsl.com

---

Attn:

**Akari Ihara**  
**Myounghee Noh & Associates, LLC**  
**99-1046 Iwaena Street**  
**Suite 210A**  
**Aiea, HI 96701**

10/25/2017

Phone: (808) 484-9214

Fax:

The following analytical report covers the analysis performed on samples submitted to EMSL Analytical, Inc. on 10/23/2017. The results are tabulated on the attached data pages for the following client designated project:

**2388-3**

The reference number for these samples is EMSL Order #011708485. Please use this reference when calling about these samples. If you have any questions, please do not hesitate to contact me at (856) 303-2500.

Approved By:

---

Phillip Worby, Environmental Chemistry  
Laboratory Director



The test results contained within this report meet the requirements of NELAP and/or the specific certification program that is applicable, unless otherwise noted.  
NELAP Certifications: NJ 03036, NY 10872, PA 68-00367, CA ELAP 1877

The samples associated with this report were received in good condition unless otherwise noted. This report relates only to those items tested as received by the laboratory. The QC data associated with the sample results meet the recovery and precision requirements established by the NELAP, unless specifically indicated. All results for soil samples are reported on a dry weight basis, unless otherwise noted. This report may not be reproduced except in full and without written approval by EMSL Analytical, Inc.

**EMSL Analytical, Inc.**

200 Route 130 North, Cinnaminson, NJ 08077

Phone/Fax: (856) 303-2500 / (856) 858-4571

<http://www.EMSL.com>[EnvChemistry2@emsl.com](mailto:EnvChemistry2@emsl.com)

EMSL Order: 011708485

CustomerID: 32MYOU50

CustomerPO:

ProjectID:

Attn: **Akari Ihara**  
**Myounghee Noh & Associates, LLC**  
**99-1046 Iwaena Street**  
**Suite 210A**  
**Aiea, HI 96701**

Phone: (808) 484-9214  
 Fax:  
 Received: 10/23/17 9:15 AM

Project: 2388-3

**Analytical Results**

**Client Sample Description** 2388-PCB4A **Collected:** 10/19/2017 **Lab ID:** 011708485-0001  
 Interior Coating 0.5 MG Tank

Method	Parameter	Result	RL	Units	Prep Date	Analyst	Analysis Date	Analyst
3540C/8082A	Aroclor-1016	ND	20	mg/Kg	10/24/2017	SD	10/25/2017	EH
3540C/8082A	Aroclor-1221	ND	20	mg/Kg	10/24/2017	SD	10/25/2017	EH
3540C/8082A	Aroclor-1232	ND	20	mg/Kg	10/24/2017	SD	10/25/2017	EH
3540C/8082A	Aroclor-1242	ND	20	mg/Kg	10/24/2017	SD	10/25/2017	EH
3540C/8082A	Aroclor-1248	ND	20	mg/Kg	10/24/2017	SD	10/25/2017	EH
3540C/8082A	Aroclor-1254	73	20	mg/Kg	10/24/2017	SD	10/25/2017	EH
3540C/8082A	Aroclor-1260	210	20	mg/Kg	10/24/2017	SD	10/25/2017	EH
3540C/8082A	Aroclor-1262	ND	20	mg/Kg	10/24/2017	SD	10/25/2017	EH
3540C/8082A	Aroclor-1268	ND	20	mg/Kg	10/24/2017	SD	10/25/2017	EH

**Client Sample Description** 2388-PCB4B **Collected:** 10/19/2017 **Lab ID:** 011708485-0002  
 Interior Coating 0.5 MG Tank

Method	Parameter	Result	RL	Units	Prep Date	Analyst	Analysis Date	Analyst
3540C/8082A	Aroclor-1016	ND	19	mg/Kg	10/24/2017	SD	10/25/2017	EH
3540C/8082A	Aroclor-1221	ND	19	mg/Kg	10/24/2017	SD	10/25/2017	EH
3540C/8082A	Aroclor-1232	ND	19	mg/Kg	10/24/2017	SD	10/25/2017	EH
3540C/8082A	Aroclor-1242	ND	19	mg/Kg	10/24/2017	SD	10/25/2017	EH
3540C/8082A	Aroclor-1248	ND	19	mg/Kg	10/24/2017	SD	10/25/2017	EH
3540C/8082A	Aroclor-1254	51	19	mg/Kg	10/24/2017	SD	10/25/2017	EH
3540C/8082A	Aroclor-1260	170	19	mg/Kg	10/24/2017	SD	10/25/2017	EH
3540C/8082A	Aroclor-1262	ND	19	mg/Kg	10/24/2017	SD	10/25/2017	EH
3540C/8082A	Aroclor-1268	ND	19	mg/Kg	10/24/2017	SD	10/25/2017	EH

**Client Sample Description** 2388-PCB4C **Collected:** 10/19/2017 **Lab ID:** 011708485-0003  
 Interior Coating 0.5 MG Tank

Method	Parameter	Result	RL	Units	Prep Date	Analyst	Analysis Date	Analyst
3540C/8082A	Aroclor-1016	ND	14	mg/Kg	10/24/2017	SD	10/25/2017	EH
3540C/8082A	Aroclor-1221	ND	14	mg/Kg	10/24/2017	SD	10/25/2017	EH
3540C/8082A	Aroclor-1232	ND	14	mg/Kg	10/24/2017	SD	10/25/2017	EH
3540C/8082A	Aroclor-1242	ND	14	mg/Kg	10/24/2017	SD	10/25/2017	EH
3540C/8082A	Aroclor-1248	ND	14	mg/Kg	10/24/2017	SD	10/25/2017	EH
3540C/8082A	Aroclor-1254	39	14	mg/Kg	10/24/2017	SD	10/25/2017	EH
3540C/8082A	Aroclor-1260	170	14	mg/Kg	10/24/2017	SD	10/25/2017	EH
3540C/8082A	Aroclor-1262	ND	14	mg/Kg	10/24/2017	SD	10/25/2017	EH
3540C/8082A	Aroclor-1268	ND	14	mg/Kg	10/24/2017	SD	10/25/2017	EH



## EMSL Analytical, Inc.

200 Route 130 North, Cinnaminson, NJ 08077

Phone/Fax: (856) 303-2500 / (856) 858-4571

<http://www.EMSL.com>

[EnvChemistry2@emsl.com](mailto:EnvChemistry2@emsl.com)

EMSL Order:	011708485
CustomerID:	32MYOU50
CustomerPO:	
ProjectID:	

### Definitions:

ND - indicates that the analyte was not detected at the reporting limit

RL - Reporting Limit (Analytical)



**Asbestos Chain of Custody**  
**EMSL Order Number (Lab Use Only):**

011708485

LATESTING  
 520 MISSION STREET  
 SOUTH PASADENA, CA 91030  
 PHONE: (800) 303-0047  
 FAX: (323) 254-9962

RECEIVED  
 EMSL  
 17 OCT 2017 AM 9:21

**Company:** Myounghee Noh & Associates L.L.C  
**Street:** 99-1046 Iwaena St.  
**City:** Aiea **State/Province:** Hawaii **Zip/Postal Code:** 96701 **Country:** U.S.A.  
**Report To (Name):** Akari Ihara **Telephone #:** 808-480-9214  
**Email Address:** akari@noh-associates.com **Fax #:** **Purchase Order:** 2388.3  
**Project Name/Number:** 2388 **Please Provide Results:**  Fax  Email  Mail  
**U.S. State Samples Taken:** Hawaii **Connecticut Samples:**  Commercial  Residential

**Turnaround Time (TAT) Options\* - Please Check**  
 3 Hour  6 Hour  24 Hour  48 Hour  72 Hour  96 Hour  1 Week  2 Week

\*For TEM Air 3 hr through 6 hr, please call ahead to schedule. \*There is a premium charge for 3 Hour TEM AHERA or EPA Level II TAT. You will be asked to sign an authorization form for this service. Analysis completed in accordance with EMSL's Terms and Conditions located in the Analytical Price Guide.

**PCM - Air**  Check if samples are from NY  
 NIOSH 7400  
 w/ OSHA 8hr. TWA  
**PLM - Bulk (reporting limit)**  
 PLM EPA 600/R-93/116 (<1%)  
 PLM EPA NOB (<1%)  
 Point Count  
 400 (<0.25%)  1000 (<0.1%)  
 Point Count w/Gravimetric  
 400 (<0.25%)  1000 (<0.1%)  
 NYS 198.1 (friable in NY)  
 NYS 198.6 NOB (non-friable-NY)  
 NIOSH 9002 (<1%)

**TEM - Air**  4-4.5hr TAT (AHERA only)  
 AHERA 40 CFR, Part 763  
 NIOSH 7402  
 EPA Level II  
 ISO 10312

**TEM - Bulk**  
 TEM EPA NOB  
 NYS NOB 198.4 (non-friable-NY)  
 Chatfield SOP  
 TEM Mass Analysis-EPA 600 sec. 2.5

**TEM - Water:** EPA 100.2  
 Fibers >10µm  Waste  Drinking  
 All Fiber Sizes  Waste  Drinking

**TEM- Dust**  
 Microvac - ASTM D 5755  
 Wipe - ASTM D6480  
 Carpet Sonication (EPA 600/J-93/167)

**Soil/Rock/Vermiculite**  
 PLM CARB 435 - A (0.25% sensitivity)  
 PLM CARB 435 - B (0.1% sensitivity)  
 TEM CARB 435 - B (0.1% sensitivity)  
 TEM CARB 435 - C (0.01% sensitivity)  
 TEM Qual. via Filtration Technique  
 TEM Qual. via Drop-Mount Technique

**Other:**  
 PCB Bulk

Check For Positive Stop - Clearly Identify Homogenous Group **Filter Pore Size (Air Samples):**  0.8µm  0.45µm

**Samplers Name:** Danny Falanag **Samplers Signature:** [Signature]

Sample #	Sample Description	Volume/Area (Air) HA # (Bulk)	Date/Time Sampled
① 2388-PCB 4A	Interior coating 0.5 MG Tank	16 bulk	10/19/2017
② 2388-PCB 4B	↓	↓	↓
③ 2388-PCB 4C	↓	↓	↓

**Client Sample # (s):** 2388-PCB 4A - 4C **Total # of Samples:** 3

**Relinquished (Client):** Myounghee Noh **Date:** 10/19/2017 **Time:** 12:00

**Received (Lab):** [Signature] 21.5 **Date:** 10/23/17 **Time:** 09:15

**Comments/Special Instructions:**  
 Separate the black coating material please. Analyze black coating and the remaining bulk material separately. Myounghee Noh 10/19/2017 myounghee@noh-associates.com

\*Rec'd in plastic (af) [Signature]

\*per client: analyze entire sample



***Attachment H – USEPA Conditional Approval of PCB Cleanup Plan under TSCA 761.61 (c) for Pana Valley Tank #1, Kekaha, Kauai, Hawaii***



**UNITED STATES ENVIRONMENTAL PROTECTION AGENCY**

REGION IX  
75 Hawthorne Street  
San Francisco, CA 94105-3901

**OCT 16 2018**

Mr. Jerry S. Fujita  
Structural Engineer  
KAI Hawaii, Inc.  
50 S. Beretania Street #C-119C  
Honolulu, Hawaii 96813

**Re: USEPA Conditional Approval of PCB Cleanup Plan under TSCA 761.61(c) for Paua Valley Tank #1, Kekaha, Kauai, Hawaii**

Dear Mr. Fujita:

Thank you for working with the U.S. Environmental Protection Agency, Region 9 ("USEPA") to address the disposal of polychlorinated biphenyls ("PCBs") found in the County of Kauai Department of Water ("DOW") Paua Valley 0.5-million-gallon concrete drinking water Tank #1 located at Tax Map Key (4) 1-2-002:039, Kekaha, Kauai, Hawaii (the "Site"). USEPA has received and reviewed the "Risk-Based PCB Cleanup Approval Application" (the "Workplan") dated September 18, 2018 that was prepared by KAI Hawaii, Inc. ("KAI Hawaii") on behalf of DOW, which outlines DOW's plan for drainage of the tank and disposal of floating oil containing PCBs.

Paua Valley Tank #1 is located on the southwest side of the island of Kauai, on a slope above the town of Kekaha. The Site is owned by the state of Hawaii with an executive order to DOW for well and water tank purposes. A hazardous materials survey of the tank was conducted in 2017, and the coal tar lining and joint sealant were found to have PCB levels up to 283 ppm. Water in the tank was sampled at the entry point to the water system, and the result was non-detect (i.e., less than or equal to the method detection limit of 0.1 ppb). The tank is currently off-line.

The Workplan describes an approach to drain the tank and dispose of oil currently floating in a thin layer at the top of the water tank consistent with Toxic Substances Control Act ("TSCA") standards. The oily layer has been sampled for PCBs, and the result was 13 ug/L (ppb). However, since water was likely entrained in the sample, disposal is conditioned on a follow-up oil sample with improved water removal, and on PCB levels in carbon filtration media.

Following drainage of the tank, DOW will not need USEPA approval to (1) remove the PCB coating (and/or PCB caulking) from the inside of the tank, (2) recoat the interior tank surfaces after PCB coating removal, and (3) dispose of the PCB coating material consistent with all applicable TSCA PCB disposal requirements (including and not limited to requirements in 40 C.F.R. § 761.62(a) and 40 C.F.R. § 761.205, "Notification of PCB waste activity"). A liner meeting technical specifications for contact with drinking water will be needed for the tank, because drinking water cannot come into direct contact with material that once was in contact with PCBs.

The tank is located adjacent to a streambed that provides a drainage ditch for the tank. The Workplan states that the streambed was dry during previous site visits, and that the stream likely flows during times of heavy rainfall. The drainage ditch is known to be contaminated with levels of PCBs exceeding the applicable Hawaii Department of Health Tier 1 environmental action level, per the investigation report dated August 22, 2018. Remediation of soils within the drainage ditch is outside the scope of the Workplan and will be addressed subsequently.

USEPA is approving KAI Hawaii's Workplan with conditions pursuant to 40 C.F.R. § 761.61(c) (i.e., risk-based disposal standards of TSCA). DOW shall implement the Workplan as modified by the conditions listed below.

**USEPA Conditions of Approval and Additional Comments:**

1. **Tank Drainage and PCB Disposal:** The following approach shall be used to drain the tank:
  - i. Test water at the effluent line sampling tap that draws water from the bottom region of the tank to confirm the PCB concentration is below the PCB drinking water maximum contaminant limit ("MCL") of 0.5 µg/L. Consult with USEPA and HDOH about PCB concentration and obtain concurrence to discharge water.
  - ii. If the PCB concentration in water is below the MCL, slowly discharge water from the bottom of the tank to minimize mixing of the water with the PCB-containing oily layer on the water surface. The water shall be drained at a rate slow enough to allow the discharged water to infiltrate into the ground surface before reaching approximately 200 feet downstream of the reservoir discharge pipe. The discharge process shall be observed at the 200-foot location to ensure the flow rate is slow enough. Drain continuously at a slow rate until the water level reaches a depth of approximately two (2) feet.
  - iii. DOW shall sample the oil sheen using an absorbent pad. A duplicate sample shall also be taken. The absorbent pad(s) shall be dried to remove water to the extent possible before analysis for PCBs using EPA Method 8082A with Soxhlet extraction. If the oil is determined to be at or greater than 50 ppm PCBs, then the oil, the absorbent pad(s), and the activated carbon filter units, required in step iv below, shall be disposed of at a hazardous waste landfill or a TSCA waste landfill, consistent with 40 C.F.R. § 761.61(a)(5)(i)(B)(2)(iii). If the oil is determined to be less than 50 ppm PCBs, then the oil and the absorbent pad(s) can be disposed of at a municipal landfill consistent with 40 C.F.R. § 761.61(a)(5)(i)(B)(2)(ii).
  - iv. Construct an activated carbon filter system and discharge the remaining water through the filter system.
  - v. Take a follow-up water sample following the carbon filter to confirm the PCB concentration is still below the MCL. If the PCB result is above the MCL, the active carbon shall be replaced or additional treatment such as bag filters shall be added after the carbon filter.
  - vi. Sample the activated carbon filter drum units for PCBs using EPA Method 8082A with Soxhlet extraction. If the PCB concentration of the filter media is determined to be less than 50 ppm, and if the concentration of the oil sheen (via the absorbent pad samples) is also determined to be less than 50 ppm, then the drum units can be disposed of at a municipal landfill consistent with 40 C.F.R. § 761.61(a)(5)(i)(B)(2)(ii). If the PCB concentration of the filter media or the oil is determined to be at or greater than 50 ppm, the activated carbon drum units shall be disposed of at a hazardous waste landfill or a TSCA waste landfill, consistent with 40 C.F.R. § 761.61(a)(5)(i)(B)(2)(iii).
2. **Drinking Water Sampling:** Following removal of the interior PCB coating, recoating of the interior of the tank, and refilling the tank with water, DOW shall sample water from the tank at the entry point to the distribution system for PCBs on a quarterly basis for at least three (3) quarters. If results are non-detect, then sampling can go to annual in perpetuity.
3. **Disposal of PCBs:** DOW shall dispose of all waste that it generates during the PCB cleanup in accordance with the TSCA PCB regulations and other applicable federal, state, and local regulations. In determining the disposal method for the waste, DOW must comply with the anti-dilution requirements in

40 C.F.R. § 761.1(b). All bulk PCB remediation waste (i.e., oil) must be disposed of in accordance with the requirements in 40 C.F.R. § 761.61(a)(5). DOW must select appropriate disposal facilities based on the in-situ PCB concentrations of the waste.


4. **PCB Cleanup Waste Disposal:** Cleanup waste (e.g., personal protective equipment, rags, gloves, booties) shall be disposed of in accordance with 40 C.F.R. § 761.61(a)(5)(v). Disposal of all waste shall be in accordance with all federal, state, and local regulations.
5. **Equipment Decontamination:** DOW shall decontaminate non-disposable sampling tools and equipment, as well as movable equipment used during cleanup and/or additional sampling in accordance with 40 C.F.R. § 761.79(c)(2). Decontamination residues must be disposed of at their original concentration in accordance with the requirements in 40 C.F.R. § 761.79(g). Recordkeeping of the decontamination events must be maintained in accordance with the requirements in 40 C.F.R. § 761.79(f)(2). These procedures must be implemented in a manner that is protective of human health and the environment consistent with the requirements in 40 C.F.R. § 761.79(e).
6. **PCB Cleanup Report:** DOW shall submit a PCB cleanup report to USEPA, to include all relevant data and justification demonstrating that the work completed is consistent with this approval. DOW must address at a minimum all the reporting requirements set forth at 40 C.F.R. § 761.61(a)(9) and 40 C.F.R. § 761.125(c)(5).
7. **Future Proposed Modifications to Cleanup Plan:** DOW shall request any changes to the approved cleanup plan via email to USEPA, and USEPA will provide any response to the request via email.

This approval does not relieve DOW from complying with all other applicable federal, state, and local regulations and permits. Departure from the conditions of the approval without prior written permission from USEPA may result in the commencement of proceedings to revoke this approval, and/or an enforcement action. Nothing in this approval bars USEPA from imposing penalties for violations of this approval or for violations of other applicable TSCA PCB requirements or for activities not covered under this approval.

This approval only applies to the Site. USEPA reserves the right to require additional characterization and/or cleanup of PCBs at the Site if new information during additional site characterization, cleanup verification, and/or during future post-cleanup activities (e.g. redevelopment or post-redevelopment) at the property shows that PCBs remain at the Site above the approved PCB cleanup level. In addition, USEPA may require cleanup of areas immediately adjacent to the site if those areas are found to be impacted by PCBs from the Site.

USEPA appreciates the opportunity to assist DOW with this PCB cleanup. If you have any questions regarding this approval, please contact Sara Ziff at (415) 972-3536 or [ziff.sara@epa.gov](mailto:ziff.sara@epa.gov). Thank you for your cooperation.

Sincerely,

  
Jeff Scott, Director  
Land Division

cc (electronic): Eric Fujikawa, DOW  
Eric Sadoyama, Hawaii Department of Health  
Myounghee Noh, Myounghee Noh & Associates

***Attachment I – Soil PCB Investigation for Kekaha 0.5 MG Concrete Storage Tank County of  
Kauai Department of Water Kekaha Water System, Kekaha, Island of Kauai 96752***

---

**SOIL PCB INVESTIGATION FOR  
KEKAHA 0.5 MG CONCRETE STORAGE TANK  
COUNTY OF KAUAI DEPARTMENT OF WATER  
KEKAHA WATER SYSTEM  
KEKAHA, ISLAND OF KAUAI 96752**

**MNA PROJECT 2388\_3**

**AUGUST 22, 2018**



**Myounghee Noh & Associates**

**Environmental Studies and Consulting Services**

200 Kohola Street, Hilo, Hawaii, USA 96720 • 808.935.8727  
99-1046 Iwaena Street, Suite 210A, Aiea, Hawaii, USA 96701 • 808.484.9214

---

SOIL PCB INVESTIGATION FOR  
KEKAHA 0.5 MG CONCRETE STORAGE TANK  
COUNTY OF KAUAI DEPARTMENT OF WATER  
KEKAHA WATER SYSTEM  
KEKAHA, ISLAND OF KAUAI 96752

TMK (4) 1-2-002:039

MNA Project No. 2388\_3

August 22, 2018

Prepared for:

Department of Water  
County of Kauai  
4398 Pua Loke Street  
Lihue, Hawaii 96766

and

KAI Hawaii, Inc.  
50 S. Beretania Street, #C-119C  
Honolulu, Hawaii 96813

Prepared by:

Myounghee Noh & Associates, L.L.C.  
Environmental Studies and Consulting Services  
99-1046 Iwaena Street, Suite 210A, Aiea, HI 96701  
Tel (808) 484-9214  
[www.noh-associates.com](http://www.noh-associates.com)

## TABLE OF CONTENTS

<b>LIST OF ABBREVIATIONS .....</b>	<b>iv</b>
<b>EXECUTIVE SUMMARY .....</b>	<b>v</b>
<b>1.0 INTRODUCTION AND PURPOSE .....</b>	<b>1</b>
<b>2.0 BACKGROUND .....</b>	<b>1</b>
2.1 Site Description.....	1
2.1.1 Climate.....	2
2.1.2 Soils/Geology .....	3
2.1.3 Surface Water.....	3
2.1.4 Groundwater.....	3
2.2 Historic Land Use .....	4
2.3 Current/Future Land Use .....	5
2.4 Investigation History.....	5
<b>3.0 COPC AND CONCEPTUAL SITE MODEL .....</b>	<b>5</b>
3.1 Potential Contamination Sources and COPC.....	5
3.2 Primary Release Mechanism.....	6
3.3 Conceptual Site Model and Exposure Pathway .....	6
3.3.1 Surface Soil .....	6
3.3.2 Subsurface Soil.....	9
3.3.3 Groundwater .....	9
3.3.4 Surface Water.....	9
<b>4.0 SITE INVESTIGATION OBJECTIVES/DATA QUALITY OBJECTIVES.....</b>	<b>9</b>
4.1 Problem Statement.....	9
4.2 Identify Objectives and Chemicals of Potential Concern .....	10
4.3 Define the Boundary of the Study .....	10
4.4 Decision Statements.....	10
<b>5.0 SOIL SAMPLING AND ANALYSIS.....</b>	<b>10</b>
5.1 Selection of Decision Units .....	11
5.1.1 DU1.....	11
5.1.2 DU2.....	11
5.1.3 DU3.....	11
5.1.4 DU4.....	11
5.2 Vegetation Clearance .....	12
5.3 Soil Sampling Activities .....	12
5.3.1 DU1.....	12
5.3.2 DU2.....	13



5.3.3	DU3	14
5.3.4	DU4	14
5.4	Sample Chain of Custody and Transportation	14
5.5	Sample Identification	15
5.6	Decontamination Procedures	15
5.7	Investigation-Derived Waste	15
<b>6.0</b>	<b>ANALYTICAL RESULTS</b>	<b>16</b>
6.1	Regulatory Criteria	16
6.2	Data Comparison of Field Triplicate Samples	16
6.3	PCB Analytical Results	19
6.3.1	DU1	19
6.3.2	DU2	19
6.3.3	DU3	19
6.3.4	DU4	19
<b>7.0</b>	<b>LABORATORY DATA QUALITY REVIEW</b>	<b>20</b>
<b>8.0</b>	<b>SUMMARY OF RESULTS</b>	<b>20</b>
<b>9.0</b>	<b>CONCLUSION AND RECOMMENDATIONS</b>	<b>20</b>
	<b>REFERENCES</b>	<b>22</b>

## TABLES

Table 1.	Kekaha Aquifer System	4
Table 2.	Conceptual Site Model	7
Table 3.	Decision Units for PCB Analysis	11
Table 4.	PCB Analytical Results	18

## APPENDICES

### Appendix A Figures

- Figure 1. Site Location Map
- Figure 2. Topographic Map of Project Site
- Figure 3A. Decision Units for Surface Soil Sampling
- Figure 3B. Decision Units for Surface Soil Sampling
- Figure 4A. DU1 Soil Sampling Locations and Results
- Figure 4B. DU2 Soil Sampling Locations and Results
- Figure 4C. DU3 Soil Sampling Locations and Results
- Figure 4D. DU4 Soil Sampling Locations and Results

### Appendix B Photographs

### Appendix C Laboratory Analytical Report

### Appendix D Tier 1 EAL Surfer Summary Report

## LIST OF ABBREVIATIONS

bgs	below ground surface
COC	Chain-of-Custody
COPC	Chemical of Potential Concern
CSM	Conceptual Site Model
DL	Detection Limit
DOW	County of Kauai Department of Water
DU	Decision Unit
EAL	Environmental Action Levels
EHE	Environmental Hazard Evaluation
EHMP	Environmental Hazard Management Plan
EPA	Environmental Protection Agency
°F	degrees Fahrenheit
ft	feet
HDOH	State of Hawaii Department of Health
ID	Identification
IDW	Investigation-Derived Waste
kg	kilograms
LCS/LCSD	Laboratory Control Sample/Laboratory Control Sample Duplicate
LOQ	Limit of Quantitation
MCL	Maximum Contaminant Level
µg/L	micrograms per liter
mg/kg	milligrams per kilogram
MG	million gallon
MI	Multi-Incremental
MNA	Myounghee Noh & Associates, L.L.C.
MS/MSD	Matrix Spike/Matrix Spike Duplicate
PCB	Polychlorinated Biphenyls
ppb	parts per billion
PPE	Personal Protection Agency
RSD	Relative Standard Deviation
TMK	Tax Map Key
TSCA	Toxic Substances Control Act
UCL	Upper Confidence Limit
UIC	Underground Injection Control

## EXECUTIVE SUMMARY

Myounghee Noh & Associates, L.L.C. (MNA), was retained by the County of Kauai Department of Water (Project Owner) and KAI Hawaii, Inc. (Prime Architect-Engineer), to conduct a surface soil polychlorinated biphenyls (PCBs) investigation along the Paua drainage ditch, to which water was discharged from a 0.5-million gallon (MG) water storage tank in Paua Valley, Kekaha, Kauai. PCBs were previously discovered in the tank water; the source of PCBs were determined to be the interior liner materials of the tank, based on sampling and analysis of the bulk materials. Previously, the tank was emptied into the drainage ditch adjacent to the tank as needed, to control overflow or to provide access for tank interior inspections and maintenance.

The chemical of potential concern (COPC) for the site is PCB. An important property of PCBs are in their inertness; they resist both acids and alkalis and have thermal stability. This made them useful in a wide variety of applications, including dielectric fluids in electrical equipment and lubricants.

Four decision units (DUs) were established along the Paua drainage ditch from the discharge point/headwall of the tank to approximately 2,500 feet downstream from the discharge point. The DUs were established as the following:

- **DU1:** Encompassed the immediate effluent outlet and extended approximately 12 feet across laterally, as applicable, and went east from the headwall to the drainage ditch, turned toward southwest and downstream; the DU length was approximately 100 feet. A set of triplicate surface soil multi-incremental (MI) samples of 75 increments were collected from DU1 between 0-6 inches below ground surface (bgs). This DU was the closest to the tank where the tank effluent was initially released.
- **DU2:** Encompassed the center of the drainage ditch and extended approximately 12 feet across laterally, as applicable, and included the 100 to 200-ft segment downstream of the headwall, making the DU 100 feet long. A surface MI soil sample of 75 increments was collected from DU2 between 0-6 inches bgs.
- **DU3:** Encompassed the center of the drainage ditch and extended approximately 6 feet across laterally, as applicable, and included the 200 to 500-foot segment downstream of the headwall, making the DU approximately 300 feet long. A surface MI soil sample of 150 increments was collected from DU3 between 0-6 inches bgs.
- **DU4:** Encompassed the center of the drainage ditch and extended approximately 1.5 feet across laterally, as applicable, and included the 500 to 2,500-ft segment downstream of the headwall, making the DU approximately 2,000 feet long. A surface MI soil sample of 150 increments was collected between 0-6 inches bgs.

The analytical results were compared to the State of Hawaii Department of Health (HDOH) Tier 1 Environmental Action Level (EAL) for unrestricted land use of a drinking water source and with surface water closer than 150 meters, 1.2 milligrams per kilogram (mg/kg), and the U.S.

Environmental Protection Agency Toxic Substances Control Act (TSCA) Cleanup Levels for Low Occupancy Areas, 25 mg/kg.

Total PCB was 3.9 mg/kg in the DU1 primary sample, exceeding the Tier 1 EAL of 1.2 mg/kg. The DU1 duplicate and triplicate samples, however, contained 0.95 mg/kg and 0.66 mg/kg, below the EAL. The Relative Standard Deviation (RSD) of the triplicate samples was 97%. Due to this high RSD, the 95% Upper Confidence Level (UCL) for the triplicate set was compared to 150% of the EAL. The 95% UCL was 6.35 mg/kg, exceeding the 150% EAL of 1.8 mg/kg. Based on these findings, the surface soil in DU1 is determined PCB-impacted, exceeding the HDOH Tier 1 EAL. The total PCB concentration, however, was below the TSCA Cleanup Levels for Low Occupancy Areas of 25 mg/kg.

Total PCB concentrations in DU2, DU3, and DU4 soil were 0.12 mg/kg, 0.12 mg/kg, and 0.10 mg/kg, respectively, below the Tier 1 EAL of 1.2 mg/kg.

Due to the rocky site conditions along the ditch, further assessment of DU1 for deeper soil depths is neither feasible nor recommended (Photograph 2 in Appendix B). As the drainage area is mostly rocky, available soils were scarce. During the surface soil sampling, about one half of the sampling points had less than 6-inch depth soils or sediments.

The HDOH Tier 1 PCB soil EAL of 1.2 mg/kg is driven by the direct exposure hazard potential. Direct exposure hazards to human health and environment requires direct contact with contaminated soil. Direct contact can be made by incidental ingestion of soil, dermal contact with soil, and inhalation of soil particles by human and ecological receptors. Access to the drainage ditch is limited by dense vegetation and limited access pathways. Therefore, the direct contact hazard potential at the drainage ditch to on-site workers or trespassers is low. Terrestrial wildlife are expected to ingest surface soil as part of normal feeding activities; therefore, this exposure is considered a potential pathway. However, since the ditch is established with dense vegetative cover, contact with the soil is anticipated to be limited.

Based on the current and future planned use of the site and the lack of available soils, and the PCB levels below the TSCA Cleanup Level of 25 mg/kg, active soil remediation of DU1 is not recommended. Rather, an Environmental Hazard Evaluation (EHE) / Environmental Hazard Management Plan (EHMP) is recommended for long-term management which may include limited or treated impacted-effluent from the existing tank, periodical site inspections, and groundcover monitoring. The EHE must identify specific environmental hazards of PCB. Long-term management under an EHMP is required for site where soil contamination above the levels of potential concern cannot be remediated in a relatively short time frame. The EHMP must include a detailed survey of the PCB-impacted area.

## 1.0 INTRODUCTION AND PURPOSE

Myounghee Noh & Associates, L.L.C. (MNA), under contract with KAI Hawaii, Inc., conducted a soil PCB investigation along a drainage ditch, which receives waters from a 0.5-million gallon (MG) water storage tank in Paua Valley, Kekaha, Kauai. The purpose of the investigation was to evaluate the presence, if any, and levels of polychlorinated biphenyls (PCB) in soil along the Paua drainage ditch, which may have occurred when the PCB-impacted waters from the tank were drained to the ditch.



A View of Paua 0.5-MG Tank (August 2017)

## 2.0 BACKGROUND

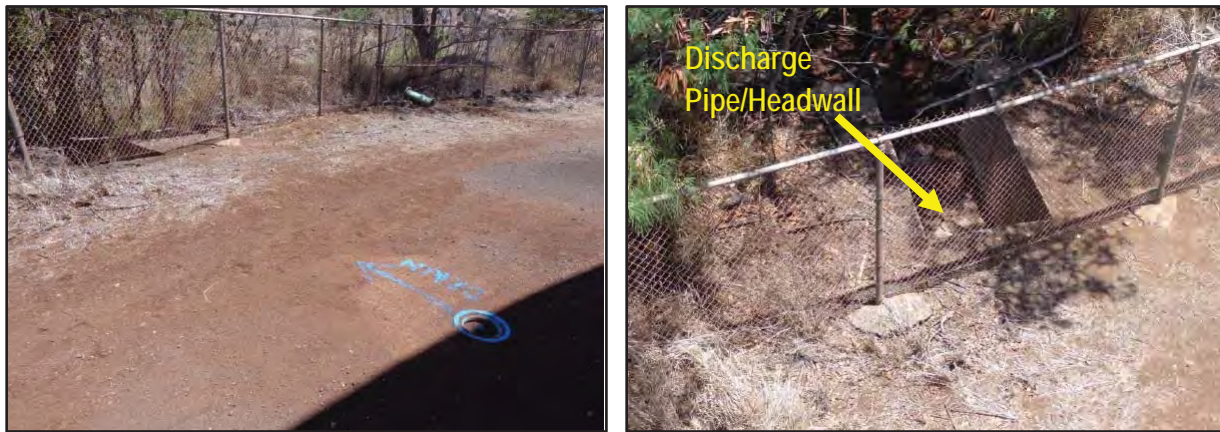
### 2.1 Site Description

The County of Kauai Department of Water (DOW) operates the 0.5-MG tank in Paua Valley, Kekaha, Kauai. The Tax Map Key (TMK) of the tank site is (4) 1-2-002:039. The site location is presented in Appendix A, Figures 1 and 2. The tank was built in 1972 and previously serviced nearly 6,000 residents in Kekaha and Waimea. The entire DOW tank site is secured in a fenced area.

In 2017, drinking water samples were collected as part of a tank maintenance project undertaken by the DOW. Measurable levels of PCB were found in the water within the tank. The State of Hawaii Department of Health (HDOH) published that in October 2017, a sample was collected from the surface water layer of the tank and contained 13 parts per billion (ppb) PCB, exceeding federal maximum contaminant level (MCL) of 0.5 ppb. Water collected from the effluent pipe, near the tank floor and leading to the distribution system, contained no measurable levels of PCB. The tank was disconnected from the supply system following the PCB discovery (ehawaii.gov, 2017). Refer to Section 2.4 for additional information.

For the public water distribution, tank water is discharged through the effluent/influent pipe located near the floor of the tank, which connects to the water system. When water removal is necessary, the tank water is discharged into the adjacent drainage ditch. Once the water is discharged to the ditch, the water flows downstream or infiltrates through the soil along the ditch.

Two methods are available to discharge water to the drainage ditch. The first method is through an overflow pipe, which provides a safeguard against overflowing of the tank. The overflow pipe extends from the tank floor to the full depth of the reservoir and has an open-end pipe at the top. If water reaches this height, water flows through the pipe and out of the tank to the drainage ditch, but not into the water distribution system. The second discharge method is through the cleanout drain line that is installed flush with the floor finish. This discharge method is used when the tank needs to be completely emptied for access or maintenance. Water from the tank is infrequently discharged from the tank using either of these methods.



Photographs of the tank discharge pipe/headwall to the drainage ditch (August 2017)



Photographs taken during tank flushing, following an inspection of the tank interior (August 2017)

### 2.1.1 Climate

Kekaha has a tropical climate. The site is located on the dry side of Kauai and receives 33 inches of rain annually (Mink & Lau, 1992). The average temperature is 75°F, with August being the

hottest month averaging 78°F and January being the coolest month with an average of 72°F (Climate-Data, 2017).

### 2.1.2 Soils/Geology

Kauai is the fourth largest and the oldest of the main Hawaiian Islands. It was formed from a single shield volcano that has been highly weathered and eroded to the point that the summit peak can be difficult to locate.

The age of Kauai has transformed much of its surface lava flows into weathered soils lending the island more erosional landforms versus the volcanic landforms found on the younger Hawaiian Islands (Morgan, 1996).

Mink and Lau (1992) describe the geology in the area as the following:

The region is a part of the southwest flank of the original volcano. Napali lavas terminate as a fossil sea cliff along a mile wide coastal plain of terrestrial and marine sediments. The Mana Plain is the most extensive and thickest accumulation of sediments on the island. Inland a few dikes have been mapped.

The United States Department of Agriculture Natural Resources Conservation Service classifies the soil at the tank site as Kekaha extremely stony silty clay loam with 0 to 35 percent slopes. Typically, this soil type is composed of extremely stony silty clay from 0 to 21 inches and clay from 21 to 70 inches. It is well-drained and more than 80 inches from the water table. Soil to the west of the drainage ditch are classified as Waiawa extremely rocky clay with 30 to 80 percent slopes. This soil type is typically composed of clay from 0 to 14 inches, before reaching the bedrock and is well drained (United States Department of Agriculture, 2008).

### 2.1.3 Surface Water

Mink and Lau (1992), describe the hydrogeology in the area as the following:

Having an average rainfall of just 33 inches, Kekaha is the driest Aquifer System in Kauai. Surface drainage is by way of small, non-perennial streams that debouch onto the Mana Plain. The Plain originally was a vast swamp but is not artificially drained to allow cropping.

The tank is located adjacent to a dry streambed which acts as the drainage ditch for the tank. During previous site visits, there were no indications of water flow in the ditch. The stream likely flows during times with heavy rainfall.

### 2.1.4 Groundwater

The HDOH Safe Drinking Water Branch established an Underground Injection Control (UIC) line to serve as a boundary between drinking water and non-drinking water portions of aquifers. Areas

above (mountain side) the UIC line are within drinking water portions of the aquifer, while areas below (ocean side) the UIC line are in non-drinking water portions of the underlying aquifer. The subject property is above the UIC line in a drinking water portion of the aquifer (Hawaii Department of Health Safe Drinking Water Branch, 2017).

The hydraulic gradient, and therefore the expected direction of travel, of the basal groundwater within the basaltic formation is, in general, from mountain areas to the shoreline. According to Mink and Lau (1992), the tank site is located above the Kekaha Aquifer System of the Waimea aquifer sector and described the groundwater as follows:

High-level dike aquifers may occur in Napali lavas in the interior near the Waimea Canyon divide. Otherwise the flank lavas contain basal groundwater. The Napali aquifer beneath the Mana Plain caprock is artesian. This aquifer has been developed as a source of irrigation supply. The sediments are saturated with brackish to salty water. Upward leakage into the sediments from the Napali artesian aquifer is the cause of the original swamp conditions. When artificial drainage for the Plain ceases, it will again become a swamp. Potable water is developed from the wells near Kekaha and Waimea. These wells are located at the inland edge of the Plain.

In 1985, three geotechnical investigation borings were advanced to determine the nature of the soils underlying the 0.5 MG water tank site. A groundwater table was not observed during the drilling down to 30 feet below ground surface (Ernest K. Hirata & Associates, Inc., 1985).

**Table 1. Kekaha Aquifer System**

<b>Aquifer Code</b>	<b>20301112</b>
Island Code	2-Kauai
Aquifer Sector	03-Waimea
Aquifer System	01-Kekaha
Aquifer Type, hydrogeology	1-Basal
Aquifer Condition	1-Unconfined
Aquifer Type, geology	2-Dike, aquifers in dike compartments
<b>Status Code</b>	<b>11111</b>
Development Stage	1-Currently used
Utility	1-Drinking
Salinity (in mg/L Cl <sup>-</sup> )	1-Fresh (<250)
Uniqueness	1-Irreplaceable
Vulnerability to Contamination	1-High

mg/L Cl<sup>-</sup>-milligrams per liter of chloride

## 2.2 Historic Land Use

The site has been used for the water storage for the Kekaha and Waimea areas since 1972 when the tank was built. U.S. Geological Survey topographic maps indicate that the area was historically used as “cropland and pasture” and was likely used by the sugarcane industry (U.S Geological Survey, 2012).



## **2.3 Current/Future Land Use**

The current land use of the site is for water storage tanks that previously serviced the Kekaha and Waimea areas. The future land use will remain the same; no future development at the site is expected.

## **2.4 Investigation History**

On 01 May 2014, DOW conducted water sampling from the tank. The water sample was collected from the floating scum layer. Total PCB as Aroclor 1260 was reported at 0.42 micrograms per liter ( $\mu\text{g/L}$  or ppb), which is below the federal MCL of 0.5  $\mu\text{g/L}$  for PCB, regulated by National Primary Drinking Water Regulation. On 13 September 2017, DOW collected a sample from the surface water of the tank. The 2017 result for total PCB was 24  $\mu\text{g/L}$ , exceeding the MCL. A pesticide Dieldrin was also detected at 0.237  $\mu\text{g/L}$ ; however, there is no MCL established for this discontinued pesticide.

On 17 August 2017, MNA was retained to conduct a building material survey to identify the source of PCB contamination. In preparation of the survey, the tank was emptied by discharging water via pipeline to the drainage ditch. PCB-containing materials were suspected on the interior tank liner materials (i.e. coating materials and sealant). Total PCB concentrations in bulk materials ranged from 10.5 milligrams per kilogram (mg/kg) to 283 mg/kg. The liner materials were observed to be in poor condition. The binding of the material had failed its integrity, indicated by peeling, cracking, or crumbling.

## **3.0 COPC AND CONCEPTUAL SITE MODEL**

### **3.1 Potential Contamination Sources and COPC**

PCBs are the primary chemical of potential concern (COPC) for this investigation. PCBs are mixtures of up to 209 individual chlorinated compounds, known as congeners, and are no longer produced in the U.S., but are still found in the environment. PCBs are a colorless to light yellow oily liquid or solid and were manufactured from 1929 until they were banned in 1979. They were used in hundreds of industrial and commercial applications due to its non-flammability, chemical stability, high boiling point, and electrical insulating properties. Many commercial PCB mixtures are known in the U.S. by the trade name Aroclor (Agency for Toxic Substances and Disease Registry, 2000).

PCBs were previously added to some specialty paints and coatings to improve their performance, primarily for industrial and/or military applications (e.g., paints manufactured to endure thermal stress, vibration or corrosivity). It is possible that these paints or coatings were previously applied in schools or other buildings built or renovated between approximately 1950 and 1979. PCB were added to specialty paints and coatings and may occur in high concentrations (U.S. Environmental Protection Agency, 2015).

PCBs do not readily biodegrade in the environment and thus may persist in the environment for extended periods of time and have the ability to migrate far distances in the air and be dispersed in areas far from where they were released. In water, small amounts may remain dissolved, but most will bind to organic particles and bottom sediments (Agency for Toxic Substances and Disease Registry, 2000).

PCBs in water are transported by diffusion and currents and are removed from the water column by sorption to suspended solids and sediments as well as from volatilization from water surfaces. Higher chlorinated congeners are more likely to sorb, while lower chlorinated congeners are more likely to volatilize. PCBs also leave the water column by concentrating in biota. PCBs in soil are unlikely to migrate to groundwater because of strong binding to soil (Agency for Toxic Substances and Disease Registry, 2000).

PCBs are taken up by small organisms and fish in water, and can bioaccumulate in arthropods, fish, and marine mammals reaching levels that may be thousands of times higher than in water. Terrestrial arthropods and mammals can also take in PCBs. PCBs levels are highest in animals high up in the food chain (Agency for Toxic Substances and Disease Registry, 2000).

### **3.2 Primary Release Mechanism**

The waters from the tank were discharged to the drainage ditch adjacent to the tank, as needed, to control overflow or provide interior tank access. During the hazardous materials survey, PCB-containing materials were identified from the interior coatings of the tank, ranging from 10.5 mg/kg to 283 mg/kg. The coating materials were observed in poor condition; peeling, cracking, or crumbling. DOW Engineering Division conducted water testing for PCB in May 2014 and September 2017. PCB were detected in the range of 0.42 µg/L to 24 µg/L. The ditch area was suspected to be contaminated with PCB due to receiving impacted discharged water or flaked coating materials from the tank.

### **3.3 Conceptual Site Model and Exposure Pathway**

The conceptual site model (CSM) is presented in Table 2. The CSM includes exposure pathway evaluations, potential exposure pathways available for transport of PCB, and their likelihood to reach human and ecological receptors.

#### **3.3.1 Surface Soil**

The tank site is protected by a fence; it is unlikely that on-site workers have accessed the discharge pipe and drainage ditch. Probability for inhalation of contaminated particulate matter and inhalation of PCB is expected to be low because much of the drainage ditch area is heavily vegetated and access to the drainage source is limited.

**Table 2. Conceptual Site Model**

Primary Sources/ Potential COPC	Primary Release Mechanism	Secondary Sources	Potential Environmental Hazards/Exposure Pathway	Hazard present during Construction			Comments
				On-site Worker	Trespasser	Ecological Receptors	
<b>PCB- containing water or coating materials from the water tank</b>	Dischargin g water to the drainage ditch	<b>Surface soil (0-6 inches bgs)</b>	Risk to Human Health	Direct Exposure	No	Yes	Access to the drainage ditch is limited by high vegetation and limited pathways. Therefore, possible direct contact (via ingestion, dermal contact, or inhalation) to on-site workers or trespassers is unlikely.
				Air Transport	Yes	Yes	Terrestrial wildlife may incidentally ingest surface soil as part of normal feeding activities; therefore, this exposure is considered a potential pathway.
				Vapor Intrusion into Buildings	No	No	The site is surrounded by thick vegetation, preventing the dispersal though surface, however, high wind may carry contaminated soil particles. Lower chlorinated congeners are volatilized.
					No	Not applicable	There are no occupied buildings within the project area.
<b>COPC: PCB</b>			Stormwater Runoff to Surface Water	No	No	Yes	PCB bind to soil particles and do not move readily to surface water. However, PCB persist in the environment and do not easily biodegrade. PCB have the potential to move from surface soil or be conveyed by runoff to ephemeral surface waters along the drainage ditch and ultimately into marine environment. Exposure pathways for direct contact and ingestion or uptake of PCB in surface water are potential pathways for terrestrial and marine plants and animals.
				Leaching	No	No	No
			Gross Contamination	Yes	Yes	Yes	There is the potential for gross contamination on surface soil adhering PCB.

**Table 2. Conceptual Site Model, Cont'd**

Primary Sources/ Potential COPC	Primary Release Mechanism	Secondary Sources	Potential Environmental Hazards/Exposure Pathway		Hazard present during Construction			Comments
			Risk to Human Health	Direct Exposure	On-site Worker	Trespasser	Ecological Receptors	
<b>PCB- containing water or coating materials from the water tank</b>  <b>COPC: PCB</b>	Dischargin g water to the drainage ditch	<b>Sub surface soil (deeper than 6 inches bgs)</b>	Direct Exposure	No	No	No	PCBs bind to soil particles and do not move readily to subsurface soils and groundwater; therefore, this exposure pathway is considered insignificant.	
			Air Transport	No	No	No		
			Vapor Intrusion into Buildings	No	No	Not applicable		
			Stormwater Runoff to Surface Water	No	No	No		
<b>PCB- containing water or coating materials from the water tank</b>  <b>COPC: PCB</b>	Dischargin g water to the drainage ditch	<b>Ground- water</b>	Leaching	No	No	No	PCBs bind to soil particles and do not move readily to subsurface soils and groundwater; therefore, this exposure pathway is considered insignificant.	
			Gross Contamination	No	No	No		
			Direct Exposure	No	No	Not applicable		
			Air Transport	No	No	Not applicable		
<b>COPC: PCB</b>			Risk to Aquatic Ecological Habitats	Not applicable	Not applicable	No		
			Gross Contamination	No	No	No		

bgs below ground surface  
PCB Polychlorinated Biphenyls

COPC Chemical of Potential Concern

PCBs bind to soil particles and the volatilization rate from soil surfaces is low. However, exposure pathways for incidental ingestion and uptake of PCBs in surface soil are potential pathways for terrestrial plants and animals. Terrestrial herbivorous wildlife and soil invertebrates, may take up PCBs from the surface soil. PCBs also tend to bio-accumulate, therefore, posing a potential exposure pathway.

### 3.3.2 Subsurface Soil

Ecological receptors are not expected to come into contact with subsurface soils because PCBs bind to soil particles and do not migrate readily to subsurface soils. Therefore, this exposure pathway is considered insignificant.

### 3.3.3 Groundwater

Because PCBs generally bind to soil particles and do not leach readily to groundwater, terrestrial ecological receptors are not expected to be exposed to groundwater; therefore, this exposure pathway is considered insignificant.

### 3.3.4 Surface Water

PCBs bind to soil particles and do not leach readily to surface water. However, PCBs do not readily biodegrade but remain in the environment, such as in sediments, and have the potential to migrate from surface soil or be conveyed by runoff to ephemeral surface waters along the drainage ditch and ultimately, into marine environment. Exposure pathways for direct contact and ingestion or uptake of PCBs in surface water are potential pathways for terrestrial and marine plants and animals.

## 4.0 SITE INVESTIGATION OBJECTIVES/DATA QUALITY OBJECTIVES

### 4.1 Problem Statement

In May 2014, DOW conducted water sampling from the top scum water layer. Measurable level of PCBs were reported at 0.42 µg/L, below the federal MCL of 0.5 µg/L. In September 2017, DOW conducted additional water sampling from the tank surface water. PCBs were reported at 24 µg/L, exceeding the MCL.

In August 2017, MNA conducted a building material survey in support of the tank rehabilitation design. PCB-containing tank inner liner was reported, ranging from 10.5 mg/kg to 283 mg/kg. The coating materials were observed in poor conditions.

The waters from the tank were discharged to Paua drainage ditch adjacent to the tank as needed for overflow control or to provide interior tank access. As a result of discharging water from the tank, PCB-impacted water or flaked tank coating materials were likely discharged from the tank into the drainage ditch. Because PCBs tend to bind to soil particles, it was suspected that the drainage ditch soils and sediments may have been impacted.

## 4.2 Identify Objectives and Chemicals of Potential Concern

The objectives of this soil sampling and analysis is to evaluate the presence of PCB-contaminated soil exceeding the HDOH Tier 1 Environmental Action Levels (EAL) in the drainage ditch. Based on MNA's current understanding of the project site and previous site investigations, described in Sections 3.0, the COPC for this site investigation are PCBs.

## 4.3 Define the Boundary of the Study

The lateral boundaries of this investigation encompass the drainage ditch from the headwall (effluent point of drainage pipe) of the tank to the intersection of Paua drainage ditch and Kokee Road which is approximately 2,500 feet downstream from the discharge point. PCB leaching to the subsurface soil or groundwater resulting from water discharge from the tank to the drainage ditch is unlikely. Thus, the vertical boundary of the investigation extends from the ground surface to 6 inches below ground surface (bgs) to collect surface soil.

## 4.4 Decision Statements

The information and data collected, including field observations and sample analytical results, were reviewed and evaluated to determine the presence and levels of PCB-impacted soil. The analytical results were compared to the current HDOH Tier 1 EAL with unrestricted land use above a drinking water resource and located less than 150 meters from surface waters (State of Hawaii Department of Health, Summer 2016, rev. January 2017). The decision statement for this soil sampling and analysis is as follows:

Decision Statement: Has PCB-contaminated water impacted the drainage ditch soil and sediment in concentrations exceeding the HDOH Tier 1 EALs?

- No – No Action if PCB are not detected in soil or if the levels are below the Tier 1 EAL, 1.2 mg/kg.
- Yes – Recommendation for (1) follow-on investigation if the investigation does not provide sufficient information for PCB contamination, or (2) preparation of an Environmental Hazard Evaluation (EHE) / Environmental Hazard Management Plan (EHMP).

## 5.0 SOIL SAMPLING AND ANALYSIS

Surface soil sampling and analysis were conducted in accordance with the HDOH HEER Office Technical Guidance Manual and implemented the use of multi-incremental (MI) sampling. Four decision units (DUs) were established to address potentially contaminated soil along the drainage ditch which received waters from the 0.5-MG tank. A map depicting each DU and sampling locations is presented in Table 3 and Figures 3A and 3B (Appendix A).

## 5.1 Selection of Decision Units

### 5.1.1 DU1

DU1 encompassed the immediate effluent outlet and extended approximately 12 feet across laterally, went east from the headwall to the drainage ditch, and turned toward southwest and downstream; the DU length was approximately 100 feet. A set of triplicate surface soil MI samples of 75 increments were collected from DU1 between 0-6 inches bgs.

### 5.1.2 DU2

DU2 encompassed the center of the drainage ditch and extended approximately 12 feet across laterally and included the 100 to 200-ft segment downstream of the headwall, making the DU 100 feet long. A surface soil MI sample of 75 increments was collected between 0-6 inches bgs.

### 5.1.3 DU3

DU3 encompassed the center of the drainage ditch and extended approximately 6 feet across laterally sides and included the 200 to 500-ft segment downstream of the headwall, making the DU approximately 300 feet long. A surface soil MI sample of 150 increments was collected between 0-6 inches bgs.

### 5.1.4 DU4

DU4 encompassed the center of the drainage ditch and extended approximately 3 feet across laterally, included the 500 to 2,500-ft segment downstream of the headwall (2,000 feet in length) and ended near Kokee Road. A surface soil MI sample of 150 increments was collected between 0-6 inches bgs.

**Table 3. Decision Units for PCB Analysis**

Sample ID (2388-)	Decision Unit	Location	Rationale	Number of Increments	Sampling Depth (in. bgs)
DU1-MIS1 (primary)	DU1	West to east from headwall to drainage ditch, and downstream. Width was approximately 12 ft wide; length was 100 ft.	Most impacted area where potentially contaminated water would have been released.	75	0-6
DU1-MIS2 (duplicate)				75	0-6
DU1-MIS3 (triplicate)				75	0-6
DU2-MIS1	DU2	100 to 200-foot portion of drainage ditch. Width was approximately 12 ft wide; length was 100 ft.	Projected lower levels of PCBs.	75	0-6
DU3-MIS1	DU3	200 to 500-foot portion of drainage ditch. Width was approximately 12 ft wide; length was 300 ft.	Projected lower levels of PCBs.	150	0-6
DU4-MIS1	DU4	500 to 2,500-foot portion of drainage ditch to nearby Kokee Rd. Width was approximately 3 ft wide; length was 2,000 ft.	Projected lowest levels of PCBs.	150	0-6

bgs	below ground surface	MIS	Multi-Increment Sample
ID	Identification	PCB	Polychlorinated Biphenyls

The collected MI samples were analyzed for PCB using the U.S. Environmental Protection Agency (EPA) Method 8082. A description of each DU and sampling locations is presented in Table 3 and Figures 3A and 3B (Appendix A).

## 5.2 Vegetation Clearance

MNA attempted soil sample collection on 04 June 2018. However, the drainage ditch was overgrown with dense vegetation making access to the ditch difficult. During 05-22 June 2018, DOW conducted vegetation clearance of approximately 2,500 feet along the drainage ditch, 12 feet wide for DU1 through DU3, and 3 feet wide along DU4. Following vegetation clearance of the drainage ditch by the DOW, soil sampling was conducted from 27-28 June 2018.

## 5.3 Soil Sampling Activities

MNA collected soil samples using the MI sampling method. Samples were analyzed for PCB by EPA Method 8082A. Photographs of the field sampling activities are presented in Appendix B.

### 5.3.1 DU1

DU1 encompassed the width of the drainage ditch and ran west to east from the headwall to the drainage ditch, turned to the southwest, and ran downstream; it was approximately 100 feet in length. On 27 June 2018, a primary, duplicate, and triplicate MI samples were collected from the DU. Entire continuous soil core plugs were collected using a hammer-head soil probe ( $\frac{7}{8}$ -in diameter) from 75 independent increment locations/per MI sample within the DU. A grid containing seventy-five 4-ft by 4-ft cells was established to determine increment sampling locations. The DU grid was three cells (12 ft) wide and 25 cells (100 ft) long. Three increments, one increment per triplicate sample, were collected from each 4-ft by 4-ft cell. Duplicate increment samples were collected generally 1 ft to the east of each primary increment sampling location; triplicate samples were collected generally 1 ft to the south from each primary increment sampling location. Figure 4A depicts the grid pattern and increment locations.

The planned sampling depth was 0-6 inches bgs; however, the surface of DU was covered with vegetation, boulders, and rocks and as a result, surface soil was scarce. Sampler refusal was encountered between 3 to 6 inches bgs in about one half of the 75 cells. When sampler refusal was encountered before reaching 6 inches bgs, soil samples were collected from surface to the refusal depth.

The entire soil plug between 0-6 inches, depending on the depth of refusal, was collected from 75 locations for the bulk MI sample. Each soil plug (increment) weighted 30-50 grams, depending on refusal depth, and was combined in the field to create a bulk MI sample, which had a final weighed mass of 2.5 kilograms (kg). The MI sample was then transferred into a 1-gallon plastic



sealable bag, sealed, double-bagged, labeled, and placed in a chilled insulated chest prior to transfer to MNA's Aiea office via cargo.

A set of triplicate surface soil MI sample of 75 increments was collected from DU1 using the same sampling procedures. The following steps were taken to collect the primary, duplicate, and triplicate samples (Figure 3A).

- *Step 1.* Incremental primary soil sampling: The soil increments for the primary sample were collected at the 75 cells. Within each cell, the soil collection was biased toward most abundant soil spot. The final weighed sample mass was 2.5 kg.
- *Step 2.* Incremental duplicate soil sampling: Once the incremental primary soil sampling was completed and the sample weighed, the duplicate soil increments were collected from approximately 1 foot east of the primary increment locations. A few attempts were made to locate available soil or sediment pockets. The final weighed sample mass was 2.9 kg.
- *Step 3.* Incremental triplicate soil sampling: Once the duplicate soil sampling was completed and the sample weighed, the triplicate soil increments were collected approximately 1 ft south of the primary increment locations. A few attempts were made to locate available soil or sediment pockets. The final weighed sample mass was 2.5 kg.

The planned sampling depth was 0-6 inches bgs; however, the sampling depth of each increment varied between to 3 to 6 inches depending on refusal depth. The sampling locations were adjusted based on accessible sampling depth, with two to three times of sampling/boring attempts per increment collected.

### 5.3.2 DU2

DU2 encompassed the width of the drainage ditch, approximately 12 feet wide, and was 100 ft to 200 ft downstream of the headwall, making it 100 ft in length. On 27 June 2018, an MI sample was collected from the DU. Entire continuous soil core plugs were collected using a hammer-head soil probe from 75 independent increment locations within the DU. A grid containing seventy-five 4-ft by 4-ft cells was established to determine increment sampling locations. The DU grid was three cells (12 feet) wide and 25 cells (100 ft) long. One increment was collected from each 4-ft by 4-ft cell. Figure 4B presents the DU dimensions and sampling grid used to determine sampling increment locations.

The planned sampling depth was 0-6 inches bgs, however, sampler refusal was encountered between 3 to 6 inches from about one half of 75 grid cells due to presence of boulders, and rocks. When sampler refusal was encountered before reaching 6 inches bgs, soil samples were collected from surface to the refusal depth. The entire soil plug between 0-6 inches depending on the refusal was collected from 75 locations for the bulk MI sample. Each soil plug (increment) weighed 30-50 grams, depending on refusal depth, and was combined in the field to create a bulk MI sample, which had a final weighed mass of 3.3 kg. The MI sample was transferred into a 1-gallon plastic sealable bag, sealed, double-bagged, labeled, and placed in a chilled insulated chest prior to transfer to MNA's Aiea office via cargo.

### 5.3.3 DU3

DU3 encompassed the width of the drainage ditch, approximately 12 feet wide, and was 200 ft to 500 ft from the headwall, making it 300 ft in length. On 27 June 2018, an MI sample was collected from the DU. Entire continuous soil core plugs were collected using a hammer-head soil probe from 150 independent increment locations within the DU. A grid containing one hundred fifty 4-ft by 6-ft cells was established, three cells (12 ft) wide and 50 cells (300 ft) long. One increment was collected from each 4 ft by 6 ft cell. Figure 4C presents the DU dimensions and sampling grid used to determine sampling increment locations.

The planned sampling depth was 0-6 inches bgs; however, sampler refusal was encountered between 3 to 6 inches from about one half of 150 sampling locations due to presence of boulder and rocks. When sampler refusal was encountered before reaching 6 inches bgs, soil samples were collected from surface to the refusal depth. The entire soil plug between 0-6 inches depending on the refusal was collected from 150 locations for the bulk MI sample. Each soil plug (increment) weighed 30-50 grams, depending on refusal depth, and was combined in the field to create a bulk MI sample, which had a final weighed mass of 6.6 kg. The MI sample was transferred into a 2-gallon plastic sealable bag, sealed, double-bagged, labeled, and placed in a chilled insulated chest prior to transfer to MNA's Aiea office via cargo.

### 5.3.4 DU4

DU4 encompassed the width of the drainage ditch, approximately 3 feet wide, and was 500 ft to 2,500 ft from the headwall, making it 2,000 ft in length. On 27 June 2018, an MI sample was collected from the DU. Entire continuous soil core plugs were collected using a hammer-head soil probe from 150 independent increment locations within the DU. A grid containing one hundred fifty 3-ft by 13-ft cells was established to determine increment sampling locations. The grid was one cell (3 ft) wide and 150 cells (approximately 2,000 ft) long. One increment was collected from each 3-ft by 13-ft cell. Figure 4D presents the DU dimensions and sampling grid.

The planned sampling depth was 0-6 inches bgs, however, sampler refusal continued between 3 to 6 inches from about one half of 150 sampling locations due to presence of boulder and rocks. When sampler refusal was encountered before reaching 6 inches bgs, soil samples were collected from surface to the refusal depth. The entire soil plug between 0-6 inches depending on the refusal was collected from 150 locations for the bulk MI sample. Each soil plug (increment) weighed 30-50 grams, depending on refusal depth, and was combined in the field to create a bulk MI sample, which had a final weighed mass of 6.6 kg. The MI sample was transferred into a 2-gallon plastic sealable bag, sealed, double-bagged, labeled, and placed in a chilled insulated chest prior to transfer to MNA's Aiea office via cargo.

## 5.4 Sample Chain of Custody and Transportation

Samples collected for analysis were recorded in the field logbook and chain-of-custody (COC) form. Following collections during 27-28 June 2018, the samples were placed in a cooler and

chilled to 2-4°C with wet ice. On 29 June 2018, one cooler was transferred via inter-island cargo with frozen blue ice to MNA's Aiea office where samples were refrigerated. The samples were transported in two coolers on 02 July 2018 to TestAmerica Laboratories, Inc., in West Sacramento, California, via overnight airfreight.

The COC served as an analytical request form and as a place to record sample condition upon receipt. Two coolers containing samples were accompanied by identical COCs, identifying the contents of the cooler. Custody seals were signed and dated and then placed over each cooler and each sample container to detect potential tampering.

## 5.5 Sample Identification

Each field sample collected was assigned a sample identification (ID) which ensures uniqueness and clarity. Each sample ID was used to indicate the sample location and MIS sampling number using the following components:

2388-DU<sub>x</sub>-MIS<sub>y</sub>

where, DU<sub>x</sub>: Sampling location (i.e. DU1: from headwall and 100 feet downstream)

MIS<sub>y</sub>: Sample number (i.e. MIS1 for primary, MIS2 for duplicate, MIS3 for triplicate)

For example, 2388-DU1-MIS1 was the sample ID used for the primary soil sample collected from DU1.

## 5.6 Decontamination Procedures

Personnel handling samples donned new nitrile gloves prior to each sampling. The sampling equipment requiring decontamination was a manual hammer-head soil probe sampler. The manual sampler was decontaminated between DUs as follows: (1) washed with a non-phosphate detergent Liquinox and potable water solution; (2) rinsed with potable water; and (3) sprayed with distilled water.

## 5.7 Investigation-Derived Waste

Investigation-derived waste (IDW) for the site investigation was limited to decontamination rinsate generated from decontaminating the non-disposable equipment; personal protective equipment (PPE), such as nitrile gloves; and disposable sampling equipment.

Less than 5 gallons of decontamination water was generated. The decontamination water was spread on site not to result in surface runoff. Disposable PPE and sampling equipment was collected in plastic trash bags, double bagged, and disposed of as solid waste.

## 6.0 ANALYTICAL RESULTS

### 6.1 Regulatory Criteria

Soil analytical results were compared to the HDOH Tier 1 EAL, 1.2 mg/kg, for unrestricted land use above a drinking water resource and located less than 150 meters to surface water. In addition, the results were also compared to the Toxic Substances Control Act (TSCA) Cleanup Level because the investigation, cleanup, verification and disposal of soil contaminated with PCB is regulated under 40 CFR 761.61 (PCB remediation waste) of the TSCA.

Under TSCA, remediation sites fall into two categories: low-occupancy areas and high-occupancy areas. In terms of frequency of occupation, a low-occupancy area limits occupancy for any individual who is not wearing dermal and respiratory protection to less than 335 hours per calendar year for porous surfaces (i.e. soil, concrete).

Examples of low-occupancy area are an electrical substation where a worker spends small amounts of time per week, an unoccupied area outside a building, an electrical equipment vault, or in the non-office space in a warehouse where occupancy is transitory. High occupancy is defined as areas where occupancy for any individual who is not wearing dermal and respiratory protection exceeds the time limits specified for low occupancy. Examples of high occupancy area are: a residence, school, day care center, sleeping quarters, a single or multiple occupancy 40 hours per week work station, a school classroom, a cafeteria in an industrial facility, a control room, or a work station at an assembly line.

For this soil investigation, the cleanup criteria for low-occupancy areas, 25 mg/kg, was used. The summary of laboratory analytical results is presented in Table 4, and the laboratory analytical report is provided in Appendix C. A summary report of the PCB EAL is provided in Appendix D, which includes a breakdown of the action levels by environmental hazard.

### 6.2 Data Comparison of Field Triplicate Samples

MNA collected a set of triplicate surface soil samples from DU1 to support the reproducibility of the field sampling technique and analytical practice and representativeness of the soil investigation. Field performance was reviewed by comparing the results of primary, duplicate, and triplicate samples of DU1. Standard deviation, average, and/or the percent relative standard deviation (RSD) between triplicates. The RSD was calculated using the following equation.

$$RSD (\%) = \frac{\text{Replicate Standard Deviation}}{\text{Replicate Mean}} \times 100\%$$

The 95% upper confidence level (UCL) of the average was calculated using the Chebyshev method for comparison to the EAL using the following equation. The 95% UCL of the average is defined as a value that, when repeatedly calculated for randomly drawn subsets of size “r” from a population, equals or exceeds the population arithmetic mean 95% of the time.

$$95\% \text{ UCL} = \text{average} + \left( \sqrt{\frac{1}{\alpha}} - 1 \times \frac{SD}{\sqrt{r}} \right)$$

Where: SD = Standard deviation; r = number of replicate samples;  
 $\alpha$  = acceptable level of potential decision error (0.05 for a 95% UCL);  
t = (1- $\alpha$ )<sup>th</sup> quantile of the Student's t-distribution with (r-1) degrees of freedom

Table 4 presents the average, standard deviation, and RSD between the triplicate samples that were collected from DU 1.

**RSD:** If the RSD between field triplicate samples is 35% or less, the total error is considered within a reasonable range for precision and reproducibility for field sampling activities. The percent RSD of the set of DU1 triplicate was 97%, indicating lower precision and confidence in the replicate data. This high RSD may have resulted from rocky site conditions and uneven soil availability of the DU.

As discussed in Section 5.3.1, the surface of DU was covered with dense vegetation, boulders, and rocks and, as a result, surface soil was scarce. During sample collection, MNA searched for soil pockets found between boulders and rocks. Additionally, the sampling depth of each increment varied due to sample refusal encountered between 0-6 inches bgs. The sampling locations and depths were adjusted based on soil accessibility. Approximately two to three samplings/borings were attempted per each increment of soil collected. These inconsistent soil availability/depths and the natural rocky conditions of DU1 accounted for the high RSD and poor precision.

**95% UCL:** Because the RSD was 97%, the 95% UCLs for the samples were calculated and estimated as presented in Table 4 in accordance with Section 4.2.7.3 Evaluation of Data Representativeness of the HDOH TGM, in order to compare the 95% UCL values to 150% of the PCB EAL, 1.8 mg/kg. This approach helps to ensure that potentially significant risk to human health and the environment is not inadvertently overlooked under a worst-case scenario, in the case that the true mean actually does exceed the action level (Hawaii Department of Health Office of Hazard Evaluation and Emergency Reponse, 2008).

**Table 4. PCB Analytical Results**

Sampling Locations/ Sample ID	Analytical Results (mg/kg)							Regulatory Criteria		
	DU1			DU2	DU3	DU4	HDOH EAL	150% HDOH EAL	TSCA Cleanup Standards for Low Occupancy	
	DU1-MIS1 (Primary)	DU1-MIS2 (Duplicate)	DU1-MIS3 (TriPLICATE)	DU2-MIS1	DU3-MIS1	DU4-MIS1				
PCB-1016	0.1 U M J1	0.049 U M	0.02 U M	0.0099 U M	0.01 U M	0.01 U M	U	N/A	N/A	
PCB-1221	0.15 U	0.074 U	0.03 U	0.015 U M	0.015 U	0.015 U	U	N/A	N/A	
PCB-1232	0.2 U M	0.099 U M	0.04 U M	0.02 U M	0.02 U M	0.02 U M	U	N/A	N/A	
PCB-1242	0.2 U M	0.099 U M	0.04 U M	0.02 U M	0.02 U M	0.02 U M	U	N/A	N/A	
PCB-1248	0.15 U M	0.074 U M	0.03 U M	0.015 U M	0.015 U M	0.015 U M	U M	N/A	N/A	
PCB-1254	0.1 U M	0.049 U M	0.02 U M	0.0099 U M	0.01 U M	0.01 U M	U M	N/A	N/A	
PCB-1260	3 D J1	0.51 D	0.48 D	0.032 J	0.025 J	0.0045 J	J	N/A	N/A	
<b>Total PCB</b>	<b>3.90</b>	<b>0.95</b>	<b>0.66</b>	<b>0.12</b>	<b>0.12</b>	<b>0.10</b>		<b>1.2</b>	<b>25</b>	
<b>95% UCL</b>		<b>6.35</b>		<b>0.53</b>	<b>0.53</b>	<b>0.45</b>		N/A	<b>1.8</b>	
Data Precision Review of Triplicate Samples	Mean: 1.84 mg/kg Standard Deviation: 1.79 Relative Standard Deviation (RSD): 97%							N/A	N/A	N/A

**Red values indicate levels above the laboratory limit of quantitation. Red values indicate levels above regulatory standards.**

**Regulatory Criteria:**

HDOH EAL: HDOH Tier 1 Environmental Action Levels (EAL) for unrestricted land use of a drinking water source and located less than 150 meters from surface water. 150% HDOH EAL. Per Section 4.2.7.3 of HDOH TGM, 95% UCL were compared to 150% of HDOH EAL. TSCA Cleanup Standard for Low Occupancy: 25 mg/kg in residual waste or porous surface, unless otherwise specified in 40 CFR 761.61(a)(4)(i)(B) & institutional control implemented (deed restriction). Deed restriction will be required if PCB concentration are greater than 25 mg/kg.

**Laboratory Analytical Data Qualifiers:**

- J1 Estimated: The quantitation is an estimation due to discrepancies in meeting certain analyte-specific quality control criteria.
- M Manual integrated compound.
- U Undetected at the Limit of Detection.
- D The reported value is from a dilution.
- J Estimated: The analyte was positively identified; the quantitation is an estimation

**Acronyms/Abbreviations:**

- 95% UCL 95% Upper Confidence Limit
- HDOH EAL State of Hawaii Department of Health Environmental Action Level
- ID identifier
- N/A Not Applicable or Not Available
- mg/kg milligrams per kilogram
- PCB Polychlorinated Biphenyls
- TSCA Toxic Substances Control Act

**Note**

- 1) 95% UCL: Compare the 95% Upper Confidence Level for replicate data to 150% of the EAL for decision making per Section 4.2.7.3 of HDOH TGM.

## 6.3 PCB Analytical Results

### 6.3.1 DU1

PCB-1260 was measured in the primary sample at 3 milligrams per kilogram (mg/kg). PCB-1016, -1221, -1232, -1242, -1248, and -1254 were also measured, but below the limit of quantitation (LOQ) ranging from 0.1 mg/kg to 0.2 mg/kg. Total PCB was calculated as 3.90 mg/kg, exceeding the HDOH Tier 1 EAL of 1.2 mg/kg, but below the TSCA cleanup level for low-occupancy areas of 25 mg/kg.

The duplicate sample had a measureable level of PCB-1260 of 0.51 mg/kg. Other PCB Arochlor mixtures were measured, but below the LOQ, ranging from 0.049 mg/kg to 0.099 mg/kg. Total PCB was calculated at 0.95 mg/kg, below the EAL of 1.2 mg/kg.

The triplicate sample had a measureable level of PCB-1260 at 0.48 mg/kg. Other PCB Arochlor mixtures were measured but below the LOQ, ranging from 0.02 mg/kg to 0.04 mg/kg. Total PCB was calculated as 0.66 mg/kg, below the EAL of 1.2 mg/kg.

The data comparison between triplicate samples is presented in Table 4. The RSD for total PCB was 97%. Because the RSD was between 50% and 100%, the 95% UCL was compared to 150% of the Tier 1 EAL, 1.8 mg/kg. The 95% UCL was calculated as 6.35 mg/kg, exceeding the 150% EAL of 1.8 mg/kg, but below the TSCA Cleanup Level of 25 mg/kg.

### 6.3.2 DU2

PCB-1260 was measured in the sample at 0.032 mg/kg. PCB-1016, -1221, -1232, -1242, -1248, and -1254 were also measured from 0.0099 mg/kg to 0.2 mg/kg. Total PCB was calculated as 0.12 mg/kg, one tenth of the HDOH Tier 1 EAL of 1.2 mg/kg. The 95% UCL of DU2 was calculated as 0.53 mg/kg, below the 150% EAL of 1.8 mg/kg.

### 6.3.3 DU3

PCB-1260 was measured in the sample at 0.025 mg/kg. PCB-1016, -1221, -1232, -1242, -1248, and -1254 were also measured, ranging from 0.01 mg/kg to 0.2 mg/kg. Total PCB was calculated as 0.12 mg/kg, one tenth of the HDOH Tier 1 EAL of 1.2 mg/kg. The 95% UCL of DU3 was calculated as 0.53 mg/kg, below the 150% EAL of 1.8 mg/kg.

### 6.3.4 DU4

PCB-1260 was measured in the sample at 0.0045 mg/kg. PCB-1016, -1221, -1232, -1242, -1248, and -1254 were also measured, ranging from 0.01 mg/kg to 0.21 mg/kg. Total PCB was calculated as 0.10 mg/kg, less than one tenth of the HDOH Tier 1 EAL of 1.2 mg/kg. The 95% UCL of DU3 was calculated as 0.45 mg/kg, below the 150% EAL of 1.8 mg/kg.

## **7.0 LABORATORY DATA QUALITY REVIEW**

MNA conducted a review of analytical data quality to determine the usability of the data generated by performing a data check for sample preservation methods, technical sample holding times, method blanks, laboratory control sample/laboratory control sample duplicate (LCS/LCSD), matrix spike/matrix spike duplicate (MS/MSD), and surrogate recoveries.

The technical holding time was met. All samples were labeled and recorded in a COC document. No PCB were detected in the laboratory blank sample, which indicated that the analytical processes were free of the contaminant. The LCS/LCSD, MS/MSD, and surrogate recoveries were within the laboratory acceptable ranges. All reporting limits were below the Tier 1 EAL for unrestricted land use. No anomalies were reported by the laboratory, although samples collected from DU1 Required dilutions. Based on review of the laboratory data quality information, all analytical data was considered valid and usable.

## **8.0 SUMMARY OF RESULTS**

Total PCB calculations for the primary sample from DU1 was 3.90 mg/kg, above the Tier I EAL for unrestricted land use of 1.2 mg/kg, but below the TSCA Cleanup Standard of 25 mg/kg for Low Occupancy Areas. Total PCB for the duplicate and triplicate samples from DU1 were 0.95 mg/kg and 0.66 mg/kg, respectively, with both results below the Tier 1 EAL and TSCA Cleanup Standard. The RSD of the triplicate samples was calculated at 97%. Due to the high RSD, the 95% UCL was compared to the 150% EAL for PCB, which was determined to be 1.8 mg/kg. The 95% UCL for the triplicate was 6.35 mg/kg, above the 150% PCB EAL of 1.8 kg/kg. Based on these results, the PCB concentrations within DU1 exceeds the HDOH EAL. The inconsistent soil availability/depths and the natural rocky conditions of DU1 accounted for the high RSD and poor precision. PCB in water or released flaked tank coating materials may have been unevenly distributed within the DU.

The total PCB for DU2 was 0.12 mg/kg, one tenth of the Tier 1 EAL of 1.2 mg/kg. The 95% UCL was calculated at 0.53 mg/kg, below the 150% PCB EAL of 1.8 mg/kg.

The total PCB for DU3 was 0.12 mg/kg, one tenth of the Tier 1 EAL of 1.2 mg/kg. The 95% UCL was calculated at 0.53 mg/kg, below the 150% PCB EAL of 1.8 mg/kg.

The total PCB for DU4 was 0.10 mg/kg, less than one tenth of the Tier 1 EAL of 1.2 mg/kg. The 95% UCL was calculated at 0.45 mg/kg, below the 150% PCB EAL of 1.8 mg/kg.

## **9.0 CONCLUSION AND RECOMMENDATIONS**

Measurable levels of PCB in the Kekaha 0.5-MG tank water were previously reported; the source of PCB was determined to be the interior liner materials of the tank, based on bulk materials sampling and analysis. The objective of this soil investigation was to evaluate the presence and levels of PCB-contaminated soil in the drainage ditch, which received effluent from the Kekaha 0.5-MG water storage tank in Paua Valley.



DU1. The surface soil (0-6 inches bgs) in DU1, which started from the discharge pipe to 100 feet down the drainage ditch, is found to be PCB-impacted, exceeding the HDOH Tier 1 EAL of 1.2 mg/kg, but below the TSCA Cleanup Standard of 25 mg/kg. Further delineation to assess the deeper soil depths is not feasible due to the lack of available soil, as the area was mostly rock. During the surface soil sampling, soil depths down to 6 inches were not observed at about one half of the sampled areas.

DU2, DU3, DU4. None of the surface soils in DU2, DU3, and DU4, are determined to be PCB-impacted above the Tier 1 EAL. As a result, it is unlikely that PCB-impacted soil exceeding the EAL is present outside of DU1 surface soil.

The HDOH Tier 1 PCB soil EAL of 1.2 mg/kg is driven by the direct exposure hazard. Direct exposure hazards to human health and environment involves direct contact with contaminated soil. Direct contact can be made by incidental ingestion of soil, dermal contact with soil, and inhalation of soil particles by human and ecological receptors. Access to the drainage ditch is limited by dense vegetation and limited access pathways. Therefore, the direct contact hazard at the drainage ditch to on-site workers or trespassers is unlikely. Terrestrial wildlife are expected to ingest surface soil as part of normal feeding activities; therefore, this exposure is considered a potential pathway. However, since the drainage ditch is dense with vegetative cover, contact to the soil is limited.

Based on the current and future planned use of the site and lack of available soils in DU1, and the findings of total PCB below the TSCA Cleanup Level of 25 mg/kg, active soil remediation of DU1 may not be necessary or feasible. Rather, an EHE / EHMP is recommended to control the residual PCBs in DU1 soil for long-term management which may include limited or treated impacted-effluent from the existing tank, periodical site inspections, and ground cover monitoring. The EHE must identify specific environmental hazards. Long-term management under an EHMP is required for site where soil contamination above the levels of potential concern cannot be remediated in a relatively short time frame. The EHMP must include a detailed survey of the PCB-impacted area.

## REFERENCES

- Agency for Toxic Substances and Disease Registry. (2000, November). *Toxicological Profile for Polychlorinated Biphenyls (PCBs)*. Retrieved from Agency for Toxic Substances and Disease Registry: <https://www.atsdr.cdc.gov/toxprofiles/tp.asp?id=142&tid=26>
- Climate-Data. (2017, December 13). *Climate: Kekaha*. Retrieved from Climate-Data.Org: <https://en.climate-data.org/location/766106/>
- ehawaii.gov. (2017, December 4). *Governor of the State of Hawaii*. Retrieved from DOH News Release: Organic Chemical Round in Kauai Water Tank: <https://governor.hawaii.gov/newsroom/latest-news/doh-news-release-organic-chemical-found-in-kauai-water-tank/>
- Ernest K. Hirata & Associates, Inc. (1985). *Foundation Investigation 0.5 MG Water Tank, Paua Valley, Kekaha, Kauai, Hawaii*.
- Hawaii Department of Health Office of Hazard Evaluation and Emergency Reponse. (2008). *Technical Guidance Manual for the Implementation of the Hawai'i State Contingency Plan*. Honolulu: Hawaii Department of Health Office of Hazard Evaluation and Emergency Reponse.
- Hawaii Department of Health Safe Drinking Water Branch. (2017, August 11). *UIC Map of Kauai*. Retrieved from Underground Injection Control (UIC) Program: <http://health.hawaii.gov/sdwb/underground-injection-control-program/>
- Mink, J. F., & Lau, L. S. (1992). *Aquifer Identification and Classification for Kauai: Groundwater Protection Strategy for Hawai'i*. Honolulu: University of Hawaii, Water Resources Research Center.
- Morgan, J. R. (1996). *Hawai'i, A Unique Geography*. Honolulu: Bess Press.
- State of Hawaii Department of Health. (Summer 2016, rev. January 2017). *Evaluation of Enviromental Hazards at Sites with Contaminated Soil and Groundwater*. Retrieved from <http://hawaii.gov/health/environmental/hazard/index.html>
- U. S. Environmental Protection Agency. (2005). *Polychlorinated Biphenyl (PCB) Site Revitalization Guidance Under the Toxic Substances Control Act (TSCA)*. U. S. Environmental Protection Agency.
- U.S Geological Survey. (2012, February 10). *USGS*. Retrieved from Land Use and Land Cover, 1976-98, Kauai County, Hawaii: <https://pubs.er.usgs.gov/publication/1128>
- U.S. Environmental Protection Agency. (2015). *PCBs in Building Materials—Questions & Answers*. Retrieved from [https://www.epa.gov/sites/production/files/2016-03/documents/pcbs\\_in\\_building\\_materials\\_questions\\_and\\_answers.pdf](https://www.epa.gov/sites/production/files/2016-03/documents/pcbs_in_building_materials_questions_and_answers.pdf)
- United States Department of Agriculture. (2008, November 13). *Natrural Resources Conservation Service*. Retrieved from Web Soil Survey: <http://websoilsurvey.nrcs.usda.gov/app/HomePage.htm>

## **APPENDIX A. FIGURES**

Figure 1. Site Location Map

Figure 2. Topographic Map of Project Site

Figure 3A. Decision Units for Surface Soil Sampling

Figure 3B. Decision Units for Surface Soil Sampling

Figure 4A. DU1 Soil Sampling Locations and Results

Figure 4B. DU2 Soil Sampling Locations and Results

Figure 4C. DU3 Soil Sampling Locations and Results

Figure 4D. DU4 Soil Sampling Locations and Results

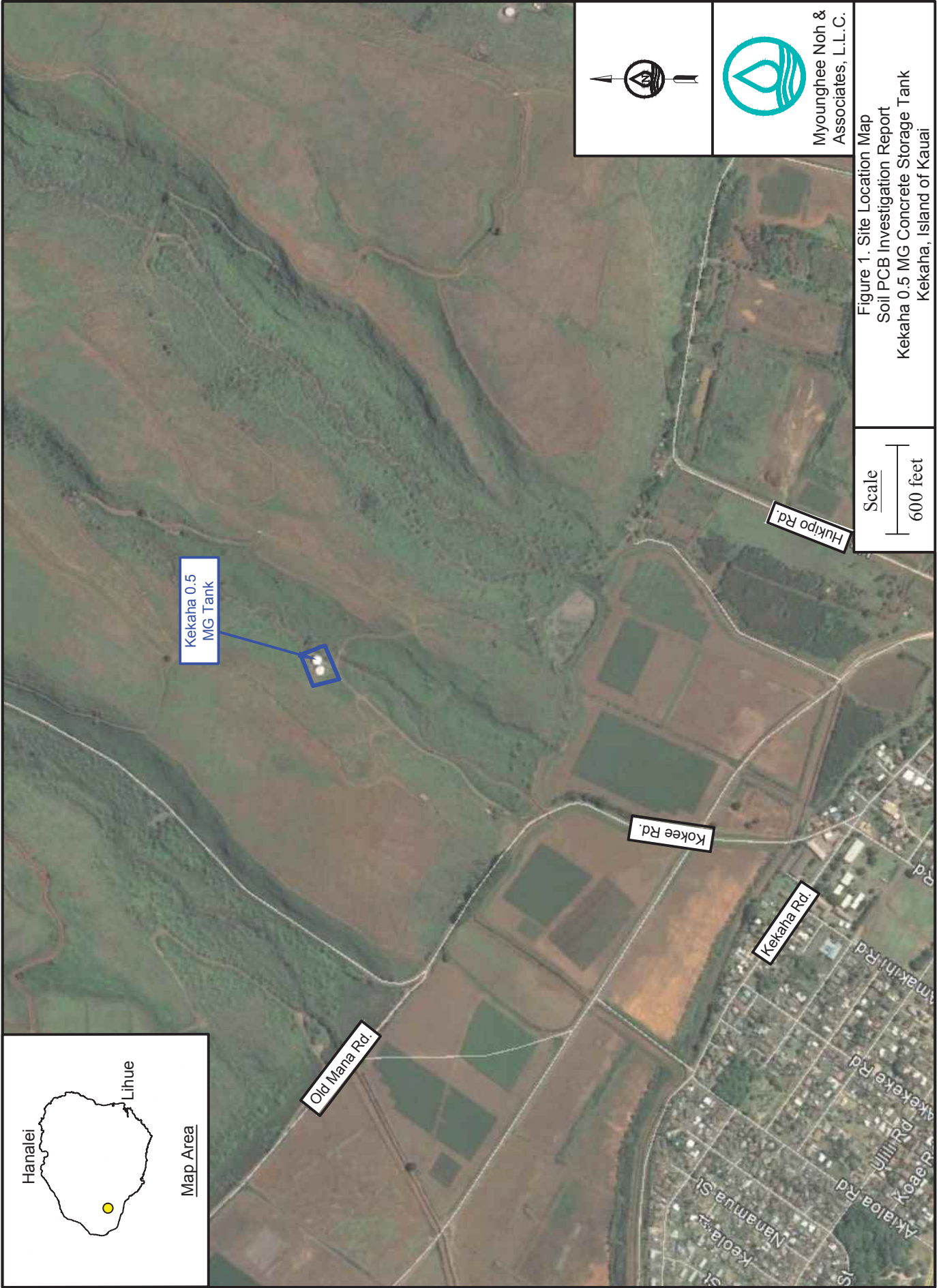
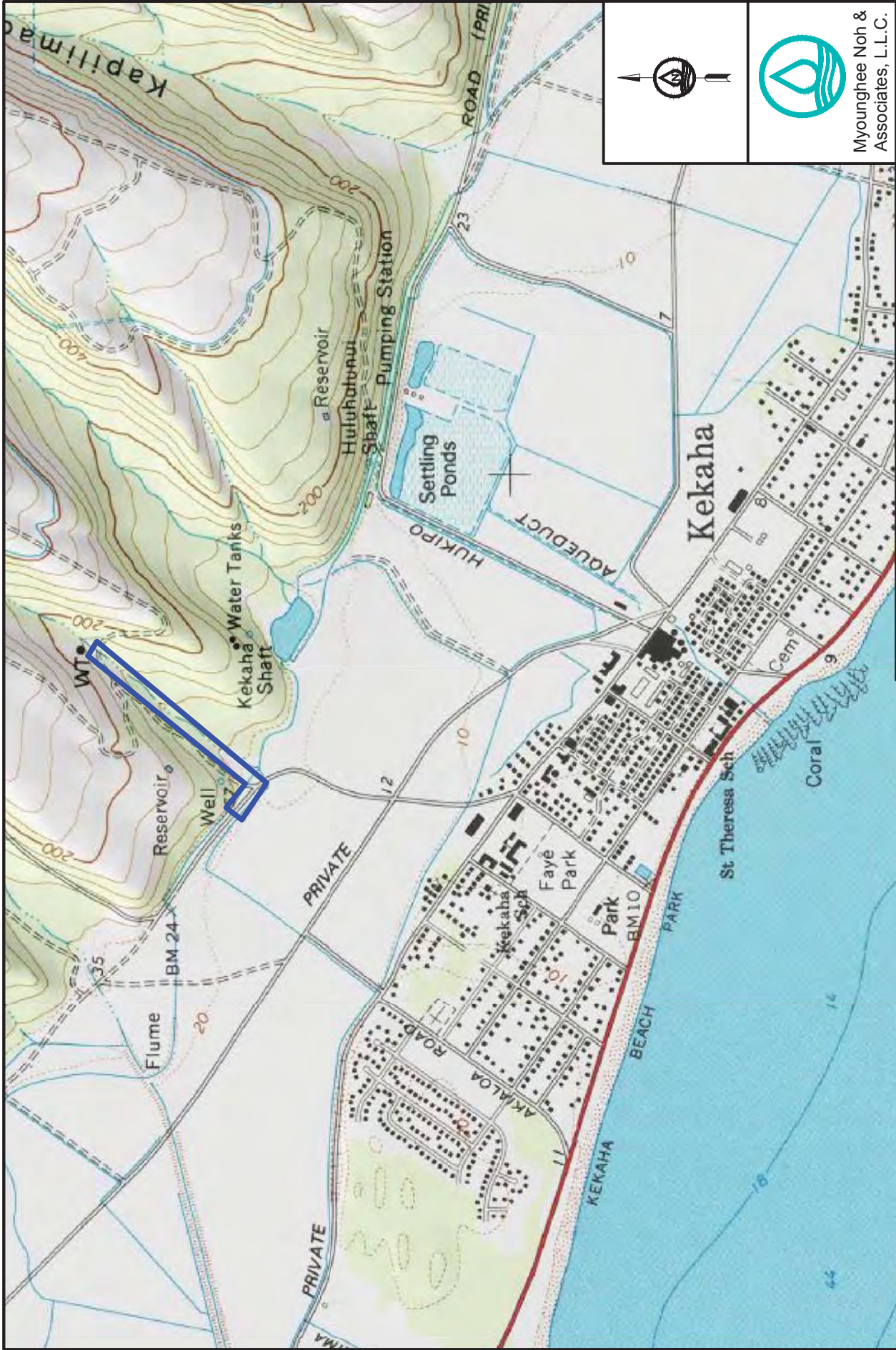


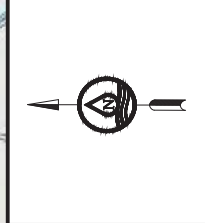
Figure 1. Site Location Map  
 Soil PCB Investigation Report  
 Kekaha 0.5 MG Concrete Storage Tank  
 Kekaha, Island of Kauai

Scale  
 600 feet



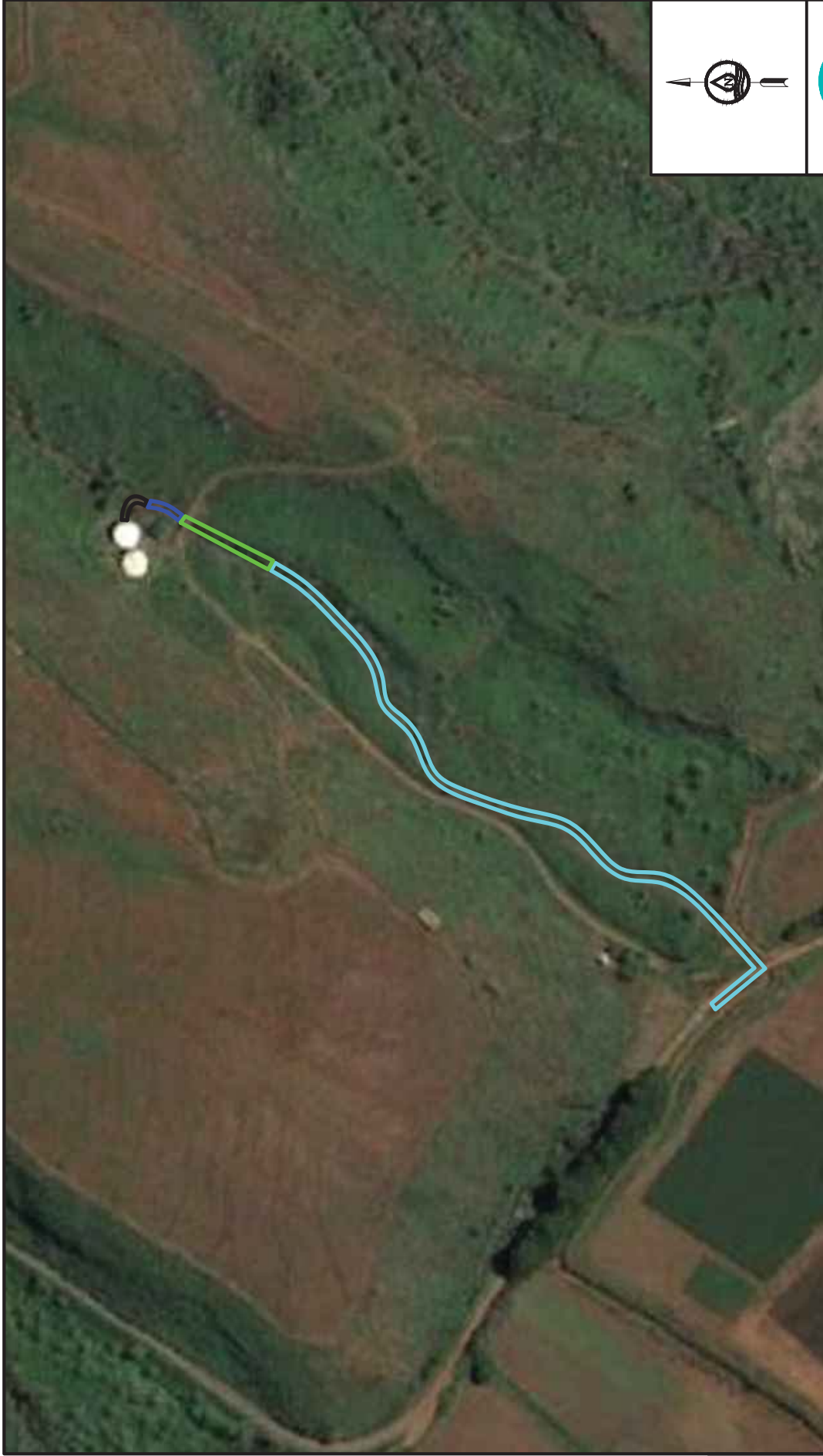
**Legend**  
 — Paua Drainage Ditch

**Scale (ft.)**  
 0 600 1,200 1,800



Myounghee Noh & Associates, L.L.C.

Figure 2. Topographic Map of Project Site  
 Soil PCB Investigation Report  
 Kekaha 0.5 MG Concrete Storage Tank  
 Kekaha, Island of Kauai



Legend

Tank diameter is 69 feet.

— DU1 Boundary (Triplicate Sample)

— DU2 Boundary

— DU3 Boundary

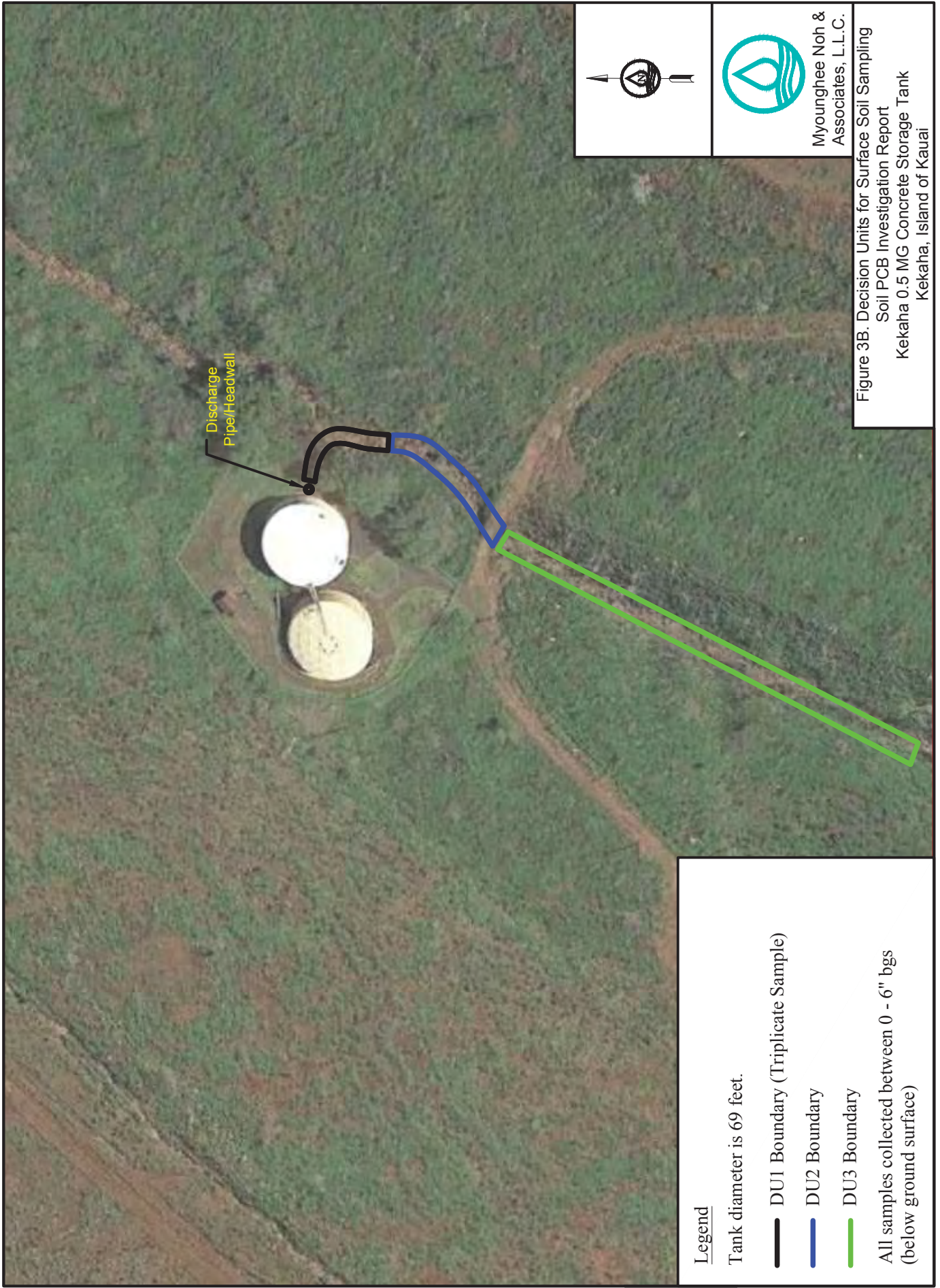
— DU4 Boundary

All samples collected between 0 - 6" bgs (below ground surface).  
Detailed tank map with DUs 1 through 3 provided in Figure 3B.



Myounghee Noh &  
Associates, L.L.C.

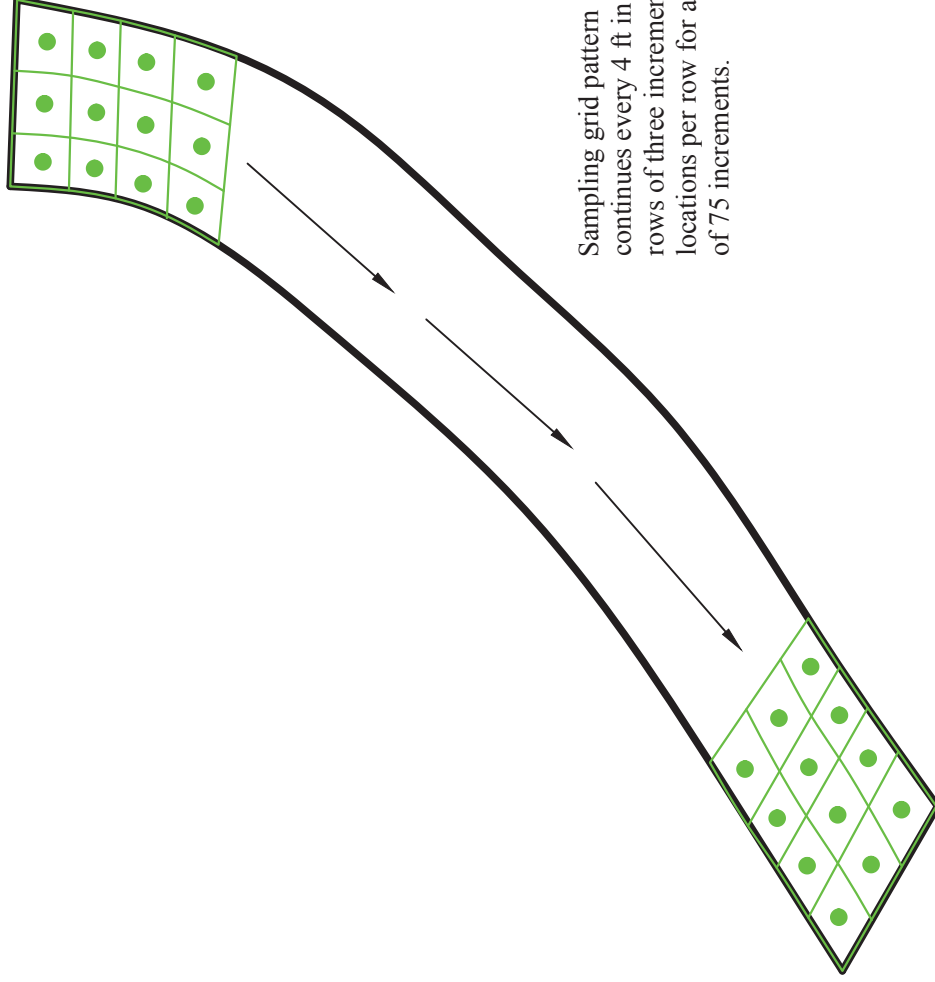
Figure 3A. Decision Units for Surface Soil Sampling  
Soil PCB Investigation Report  
Kekaha 0.5 MG Concrete Storage Tank  
Kekaha, Island of Kauai





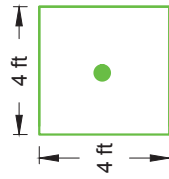


Analytical Results (mg/kg)	
Analyte	DU2-MIS1
Total PCB	0.12
95% UCL	0.53
Total PCB EAL: 1.2 mg/kg	
Total PCB TSCA Cleanup Standard: 25 mg/kg	
95% UCL EAL: 1.8 mg/kg	



Sampling grid pattern continues every 4 ft in 25 rows of three increment locations per row for a total of 75 increments.

Sampling Grid Dimensions



Legend

DU dimensions are approximately 100 ft x 12 ft.

— DU2 Boundary

● Increment Location

Increment samples (75) collected between 0 - 6" bgs (below ground surface)

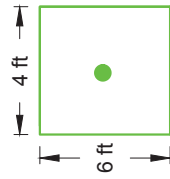


Myounghee Noh & Associates, L.L.C.

Figure 4B. DU2 Soil Sampling Locations and Results  
Soil PCB Investigation Report  
Kekaha 0.5 MG Concrete Storage Tank  
Kekaha, Island of Kauai

Analytical Results (mg/kg)	
Analyte	DU3-MIS1
Total PCB	0.12
95% UCL	0.53
Total PCB EAL: 1.2 mg/kg	
Total PCB TSCA Cleanup Standard: 25 mg/kg	
95% UCL EAL: 1.8 mg/kg	

Sampling Grid Dimensions



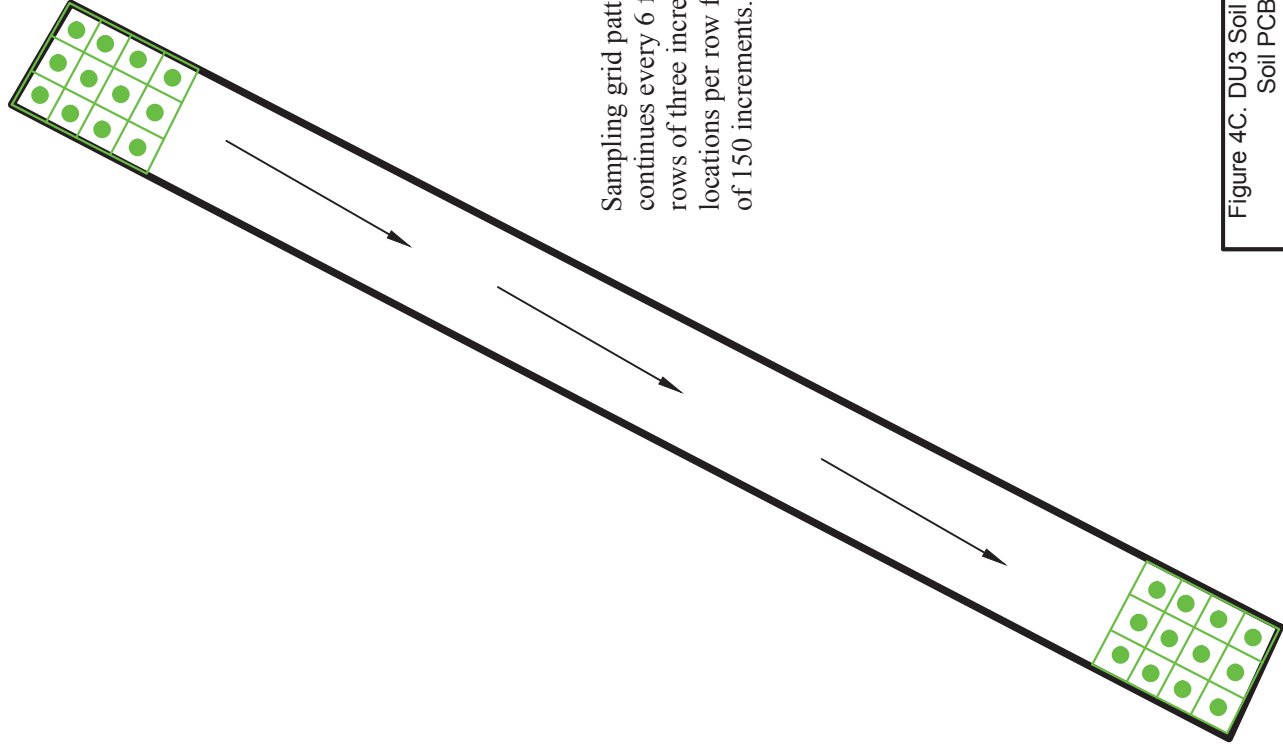
Legend

DU dimensions are approximately 300 ft x 18 ft.

— DU3 Boundary

● Increment Location

Increment samples (150) collected between 0 - 6" bgs (below ground surface)



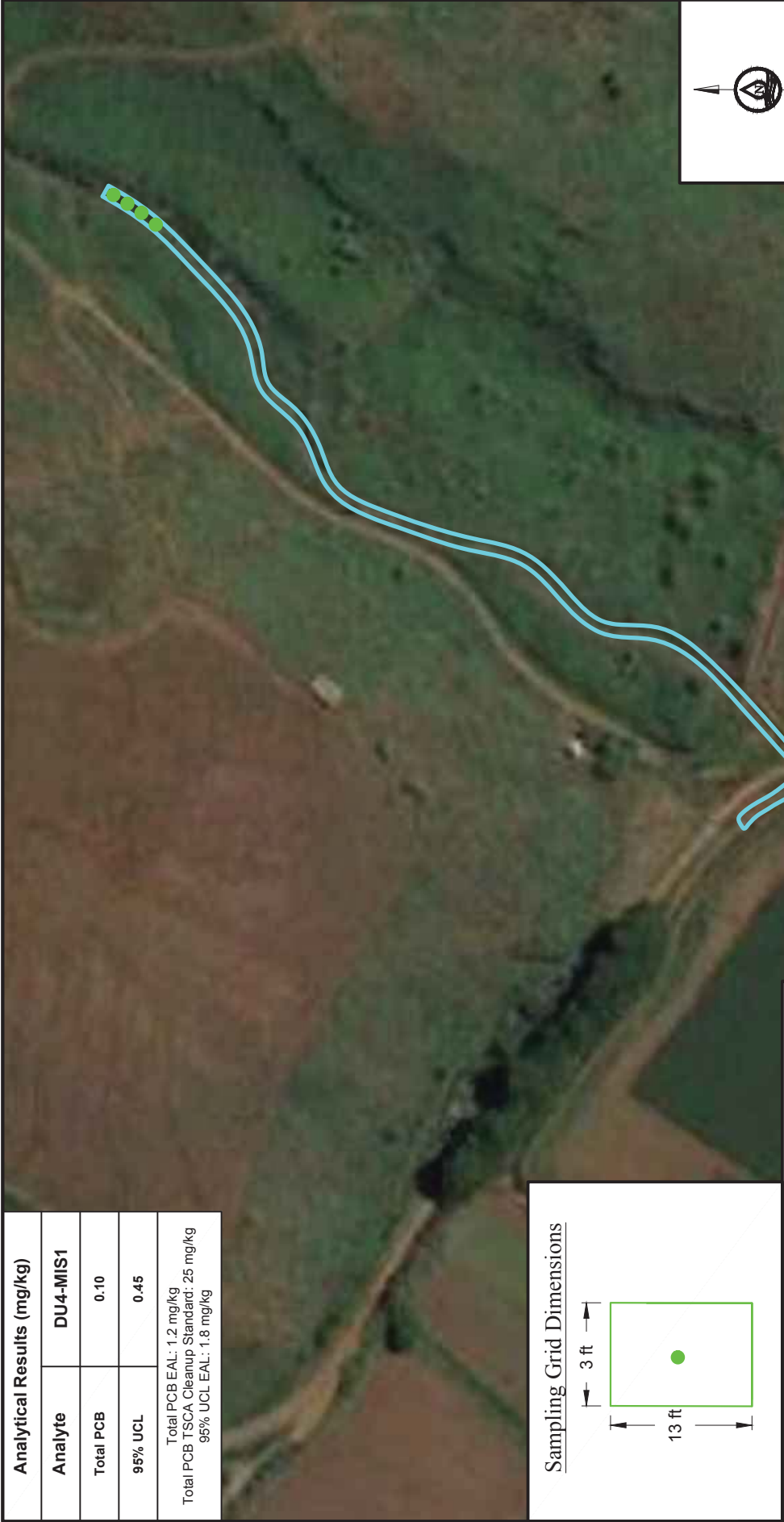
Sampling grid pattern continues every 6 ft in 50 rows of three increment locations per row for a total of 150 increments.



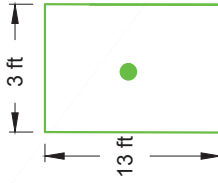
Myounghee Noh & Associates, L.L.C.

Figure 4C. DU3 Soil Sampling Locations and Results  
Soil PCB Investigation Report  
Kekaha 0.5 MG Concrete Storage Tank  
Kekaha, Island of Kauai

Analytical Results (mg/kg)	
Analyte	DU4-MIS1
Total PCB	0.10
95% UCL	0.45
Total PCB EAL: 1.2 mg/kg	
Total PCB TSCA Cleanup Standard: 25 mg/kg	
95% UCL EAL: 1.8 mg/kg	



Sampling Grid Dimensions



Legend

DU dimensions are approximately 2,000 ft x 3 ft.

- DU4 Boundary
  - Increment Location (taken inside DU boundary)
- Increment samples (150) collected between 0 - 6" bgs (below ground surface)
- Sampling pattern continues every 13 ft for a total of 150 increments.



Myounghee Noh & Associates, L.L.C.

Figure 4D. DU4 Soil Sampling Locations and Results  
Soil PCB Investigation Report  
Kekaha 0.5 MG Concrete Storage Tank  
Kekaha, Island of Kauai

## **APPENDIX B. PHOTOGRAPHS**



Photograph 1. A view of tank discharge point/headwall to the drainage ditch. The DU was 12 ft wide by 100 ft long. The width of the drainage ditch varied (27 June 2018).



Photograph 2. A view of DU1 just beyond the discharge point. The drainage ditch was covered with vegetation, boulders, and rock. The DU was 12 ft wide by 100 ft long. The width of the drainage ditch varied (27 June 2018).



Photograph 3. A view of DU 2. Vegetation was cleared by DOW enough to access the drainage ditch. Entire continuous soil core plugs were collected using a hammer-head soil probe ( $\frac{7}{8}$ -inch diameter). The soil plug was combined in a 2-gallon bag inside of a bucket to generate a bulk MI sample. Then, the MI sample was transferred into a plastic sealable bag, sealed, double-bagged, labeled, and placed in a chilled insulated chest (27 June 2018).



Photograph 4. A view of a soil increment location. Due to sampler refusal, two to three soil boring attempts were made for each soil increment collected between 0-6 inches bgs (28 June 2018).



Photograph 5. A view of DU3. Vegetation was cleared by DOW enough to access the drainage ditch (27 June 2018).



Photograph 6. A view of DU4 along the drainage ditch. Vegetation was cleared by DOW enough to access the drainage ditch (28 June 2018).



Photograph 7. Soil sampling in DU4 (28 June 2018). Dense vegetation was observed throughout the DU.



Photograph 8. A view of sample collection in DU4, along Kokee Road (28 June 2018). The DU4 in the Kokee Road vicinity was the end of the drainage ditch in a depressed area where water might be collected during heavy rainfall.

**APPENDIX C. LABORATORY ANALYTICAL REPORT**



# TestAmerica

THE LEADER IN ENVIRONMENTAL TESTING

## ANALYTICAL REPORT

TestAmerica Laboratories, Inc.  
TestAmerica Sacramento  
880 Riverside Parkway  
West Sacramento, CA 95605  
Tel: (916)373-5600

TestAmerica Job ID: 320-40847-1  
Client Project/Site: KEKAHA, ISLAND OF KAUAI

For:  
Myounghee Noh & Associates  
99-1046 Iwaena Street, Suite 210A  
Aiea, Hawaii 96701

Attn: Eunjin Kotkovetz

*Cesar C Cortes*

Authorized for release by:  
7/27/2018 6:17:35 PM

Cesar Cortes, Project Management Assistant I  
(916)373-5600  
[cesar.cortes@testamericainc.com](mailto:cesar.cortes@testamericainc.com)

### LINKS

Review your project  
results through  
**TotalAccess**

Have a Question?



Visit us at:  
[www.testamericainc.com](http://www.testamericainc.com)

*The test results in this report meet all 2003 NELAC and 2009 TNI requirements for accredited parameters, exceptions are noted in this report. This report may not be reproduced except in full, and with written approval from the laboratory. For questions please contact the Project Manager at the e-mail address or telephone number listed on this page.*

*This report has been electronically signed and authorized by the signatory. Electronic signature is intended to be the legally binding equivalent of a traditionally handwritten signature.*

*Results relate only to the items tested and the sample(s) as received by the laboratory.*

1

2

3

4

5

6

7

8

9

10

11

12

13

14

15

# Table of Contents

Cover Page . . . . .	1
Table of Contents . . . . .	2
Definitions/Glossary . . . . .	3
Case Narrative . . . . .	4
Detection Summary . . . . .	5
Client Sample Results . . . . .	6
Surrogate Summary . . . . .	8
QC Sample Results . . . . .	9
QC Association Summary . . . . .	11
Lab Chronicle . . . . .	12
Certification Summary . . . . .	14
Method Summary . . . . .	15
Sample Summary . . . . .	16
Chain of Custody . . . . .	17
Receipt Checklists . . . . .	18



# Definitions/Glossary

Client: Myounghee Noh & Associates  
Project/Site: KEKAHA, ISLAND OF KAUAI

TestAmerica Job ID: 320-40847-1

## Qualifiers

### GC Semi VOA

Qualifier	Qualifier Description
J1	Estimated: The quantitation is an estimation due to discrepancies in meeting certain analyte-specific quality control criteria.
M	Manual integrated compound.
U	Undetected at the Limit of Detection.
D	The reported value is from a dilution.
J	Estimated: The analyte was positively identified; the quantitation is an estimation
4	MS, MSD: The analyte present in the original sample is greater than 4 times the matrix spike concentration; therefore, control limits are not applicable.

## Glossary

Abbreviation	These commonly used abbreviations may or may not be present in this report.
α	Listed under the "D" column to designate that the result is reported on a dry weight basis
%R	Percent Recovery
CFL	Contains Free Liquid
CNF	Contains No Free Liquid
DER	Duplicate Error Ratio (normalized absolute difference)
Dil Fac	Dilution Factor
DL	Detection Limit (DoD/DOE)
DL, RA, RE, IN	Indicates a Dilution, Re-analysis, Re-extraction, or additional Initial metals/anion analysis of the sample
DLC	Decision Level Concentration (Radiochemistry)
EDL	Estimated Detection Limit (Dioxin)
LOD	Limit of Detection (DoD/DOE)
LOQ	Limit of Quantitation (DoD/DOE)
MDA	Minimum Detectable Activity (Radiochemistry)
MDC	Minimum Detectable Concentration (Radiochemistry)
MDL	Method Detection Limit
ML	Minimum Level (Dioxin)
NC	Not Calculated
ND	Not Detected at the reporting limit (or MDL or EDL if shown)
PQL	Practical Quantitation Limit
QC	Quality Control
RER	Relative Error Ratio (Radiochemistry)
RL	Reporting Limit or Requested Limit (Radiochemistry)
RPD	Relative Percent Difference, a measure of the relative difference between two points
TEF	Toxicity Equivalent Factor (Dioxin)
TEQ	Toxicity Equivalent Quotient (Dioxin)

# Case Narrative

Client: Myounghee Noh & Associates  
Project/Site: KEKAHA, ISLAND OF KAUAI

TestAmerica Job ID: 320-40847-1

---

## Job ID: 320-40847-1

---

Laboratory: TestAmerica Sacramento

### Narrative

#### Receipt

The samples were received on 7/3/2018 at 9:30 AM; the samples arrived in good condition, properly preserved and, where required, on ice. The temperatures of the 2 coolers at receipt time were 1.2° C and 2.9° C.

#### Method 8082A

The following samples required a dilution due to the nature of the sample matrix: DU1-MIS1 (320-40847-1), DU1-MIS1 (320-40847-1[MS]), DU1-MIS1 (320-40847-1[MSD]), DU1-MIS2 (320-40847-2) and DU1-MIS3 (320-40847-3). Because of this dilution, the surrogate spike concentration in the sample was reduced to a level where the recovery calculation does not provide useful information. Elevated reporting limits (RLs) are provided.

No additional analytical or quality issues were noted, other than those described above or in the Definitions/Glossary page.

- 1
- 2
- 3
- 4
- 5
- 6
- 7
- 8
- 9
- 10
- 11
- 12
- 13
- 14
- 15

# Detection Summary

Client: Myounghee Noh & Associates  
Project/Site: KEKAHA, ISLAND OF KAUAI

TestAmerica Job ID: 320-40847-1

## Client Sample ID: DU1-MIS1

Lab Sample ID: 320-40847-1

Analyte	Result	Qualifier	LOQ	DL	Unit	Dil Fac	D	Method	Prep Type
PCB-1260	3000	D J1	340	29	ug/Kg	10		8082A	Total/NA

## Client Sample ID: DU1-MIS2

Lab Sample ID: 320-40847-2

Analyte	Result	Qualifier	LOQ	DL	Unit	Dil Fac	D	Method	Prep Type
PCB-1260	510	D	160	14	ug/Kg	5		8082A	Total/NA

## Client Sample ID: DU1-MIS3

Lab Sample ID: 320-40847-3

Analyte	Result	Qualifier	LOQ	DL	Unit	Dil Fac	D	Method	Prep Type
PCB-1260	480	D	66	5.8	ug/Kg	2		8082A	Total/NA

## Client Sample ID: DU2-MIS1

Lab Sample ID: 320-40847-4

Analyte	Result	Qualifier	LOQ	DL	Unit	Dil Fac	D	Method	Prep Type
PCB-1260	32	J	33	2.9	ug/Kg	1		8082A	Total/NA

## Client Sample ID: DU3-MIS1

Lab Sample ID: 320-40847-5

Analyte	Result	Qualifier	LOQ	DL	Unit	Dil Fac	D	Method	Prep Type
PCB-1260	25	J	34	3.0	ug/Kg	1		8082A	Total/NA

## Client Sample ID: DU4-MIS1

Lab Sample ID: 320-40847-6

Analyte	Result	Qualifier	LOQ	DL	Unit	Dil Fac	D	Method	Prep Type
PCB-1260	4.5	J	34	3.0	ug/Kg	1		8082A	Total/NA

This Detection Summary does not include radiochemical test results.

TestAmerica Sacramento

# Client Sample Results

Client: Myounghee Noh & Associates  
 Project/Site: KEKAHA, ISLAND OF KAUAI

TestAmerica Job ID: 320-40847-1

## Client Sample ID: DU1-MIS1

Date Collected: 06/27/18 16:00

Date Received: 07/03/18 09:30

## Lab Sample ID: 320-40847-1

Matrix: Solid

### Method: 8082A - Polychlorinated Biphenyls (PCBs) by Gas Chromatography

Analyte	Result	Qualifier	LOQ	DL	Unit	D	Prepared	Analyzed	Dil Fac
PCB-1016	100	U M J1	340	35	ug/Kg		07/10/18 11:16	07/26/18 12:33	10
PCB-1221	150	U	340	53	ug/Kg		07/10/18 11:16	07/26/18 12:33	10
PCB-1232	200	U M	340	65	ug/Kg		07/10/18 11:16	07/26/18 12:33	10
PCB-1242	200	U M	340	75	ug/Kg		07/10/18 11:16	07/26/18 12:33	10
PCB-1248	150	U M	340	58	ug/Kg		07/10/18 11:16	07/26/18 12:33	10
PCB-1254	100	U M	340	27	ug/Kg		07/10/18 11:16	07/26/18 12:33	10
<b>PCB-1260</b>	<b>3000</b>	<b>D J1</b>	340	29	ug/Kg		07/10/18 11:16	07/26/18 12:33	10

Surrogate	%Recovery	Qualifier	Limits	Prepared	Analyzed	Dil Fac
DCB Decachlorobiphenyl	113		60 - 125	07/10/18 11:16	07/26/18 12:33	10
DCB Decachlorobiphenyl	123		60 - 125	07/10/18 11:16	07/26/18 12:33	10

## Client Sample ID: DU1-MIS2

Date Collected: 06/27/18 16:00

Date Received: 07/03/18 09:30

## Lab Sample ID: 320-40847-2

Matrix: Solid

### Method: 8082A - Polychlorinated Biphenyls (PCBs) by Gas Chromatography

Analyte	Result	Qualifier	LOQ	DL	Unit	D	Prepared	Analyzed	Dil Fac
PCB-1016	49	U M	160	17	ug/Kg		07/10/18 11:16	07/26/18 13:35	5
PCB-1221	74	U	160	26	ug/Kg		07/10/18 11:16	07/26/18 13:35	5
PCB-1232	99	U M	160	32	ug/Kg		07/10/18 11:16	07/26/18 13:35	5
PCB-1242	99	U M	160	37	ug/Kg		07/10/18 11:16	07/26/18 13:35	5
PCB-1248	74	U M	160	28	ug/Kg		07/10/18 11:16	07/26/18 13:35	5
PCB-1254	49	U M	160	13	ug/Kg		07/10/18 11:16	07/26/18 13:35	5
<b>PCB-1260</b>	<b>510</b>	<b>D</b>	160	14	ug/Kg		07/10/18 11:16	07/26/18 13:35	5

Surrogate	%Recovery	Qualifier	Limits	Prepared	Analyzed	Dil Fac
DCB Decachlorobiphenyl	80		60 - 125	07/10/18 11:16	07/26/18 13:35	5
DCB Decachlorobiphenyl	85		60 - 125	07/10/18 11:16	07/26/18 13:35	5

## Client Sample ID: DU1-MIS3

Date Collected: 06/27/18 16:00

Date Received: 07/03/18 09:30

## Lab Sample ID: 320-40847-3

Matrix: Solid

### Method: 8082A - Polychlorinated Biphenyls (PCBs) by Gas Chromatography

Analyte	Result	Qualifier	LOQ	DL	Unit	D	Prepared	Analyzed	Dil Fac
PCB-1016	20	U M	66	6.8	ug/Kg		07/10/18 11:16	07/26/18 13:55	2
PCB-1221	30	U	66	10	ug/Kg		07/10/18 11:16	07/26/18 13:55	2
PCB-1232	40	U M	66	13	ug/Kg		07/10/18 11:16	07/26/18 13:55	2
PCB-1242	40	U M	66	15	ug/Kg		07/10/18 11:16	07/26/18 13:55	2
PCB-1248	30	U M	66	11	ug/Kg		07/10/18 11:16	07/26/18 13:55	2
PCB-1254	20	U M	66	5.4	ug/Kg		07/10/18 11:16	07/26/18 13:55	2
<b>PCB-1260</b>	<b>480</b>	<b>D</b>	66	5.8	ug/Kg		07/10/18 11:16	07/26/18 13:55	2

Surrogate	%Recovery	Qualifier	Limits	Prepared	Analyzed	Dil Fac
DCB Decachlorobiphenyl	88		60 - 125	07/10/18 11:16	07/26/18 13:55	2
DCB Decachlorobiphenyl	90		60 - 125	07/10/18 11:16	07/26/18 13:55	2

TestAmerica Sacramento

# Client Sample Results

Client: Myounghee Noh & Associates  
 Project/Site: KEKAHA, ISLAND OF KAUAI

TestAmerica Job ID: 320-40847-1

## Client Sample ID: DU2-MIS1

Date Collected: 06/28/18 10:30

Date Received: 07/03/18 09:30

## Lab Sample ID: 320-40847-4

Matrix: Solid

### Method: 8082A - Polychlorinated Biphenyls (PCBs) by Gas Chromatography

Analyte	Result	Qualifier	LOQ	DL	Unit	D	Prepared	Analyzed	Dil Fac
PCB-1016	9.9	U M	33	3.3	ug/Kg		07/10/18 11:16	07/26/18 14:16	1
PCB-1221	15	U M	33	5.1	ug/Kg		07/10/18 11:16	07/26/18 14:16	1
PCB-1232	20	U M	33	6.3	ug/Kg		07/10/18 11:16	07/26/18 14:16	1
PCB-1242	20	U M	33	7.3	ug/Kg		07/10/18 11:16	07/26/18 14:16	1
PCB-1248	15	U M	33	5.6	ug/Kg		07/10/18 11:16	07/26/18 14:16	1
PCB-1254	9.9	U M	33	2.7	ug/Kg		07/10/18 11:16	07/26/18 14:16	1
<b>PCB-1260</b>	<b>32</b>	<b>J</b>	33	2.9	ug/Kg		07/10/18 11:16	07/26/18 14:16	1

Surrogate	%Recovery	Qualifier	Limits	Prepared	Analyzed	Dil Fac
DCB Decachlorobiphenyl	71		60 - 125	07/10/18 11:16	07/26/18 14:16	1
DCB Decachlorobiphenyl	75		60 - 125	07/10/18 11:16	07/26/18 14:16	1

## Client Sample ID: DU3-MIS1

Date Collected: 06/28/18 14:30

Date Received: 07/03/18 09:30

## Lab Sample ID: 320-40847-5

Matrix: Solid

### Method: 8082A - Polychlorinated Biphenyls (PCBs) by Gas Chromatography

Analyte	Result	Qualifier	LOQ	DL	Unit	D	Prepared	Analyzed	Dil Fac
PCB-1016	10	U M	34	3.5	ug/Kg		07/10/18 11:16	07/26/18 14:36	1
PCB-1221	15	U	34	5.3	ug/Kg		07/10/18 11:16	07/26/18 14:36	1
PCB-1232	20	U M	34	6.6	ug/Kg		07/10/18 11:16	07/26/18 14:36	1
PCB-1242	20	U M	34	7.6	ug/Kg		07/10/18 11:16	07/26/18 14:36	1
PCB-1248	15	U M	34	5.8	ug/Kg		07/10/18 11:16	07/26/18 14:36	1
PCB-1254	10	U M	34	2.8	ug/Kg		07/10/18 11:16	07/26/18 14:36	1
<b>PCB-1260</b>	<b>25</b>	<b>J</b>	34	3.0	ug/Kg		07/10/18 11:16	07/26/18 14:36	1

Surrogate	%Recovery	Qualifier	Limits	Prepared	Analyzed	Dil Fac
DCB Decachlorobiphenyl	78		60 - 125	07/10/18 11:16	07/26/18 14:36	1
DCB Decachlorobiphenyl	82		60 - 125	07/10/18 11:16	07/26/18 14:36	1

## Client Sample ID: DU4-MIS1

Date Collected: 06/28/18 16:30

Date Received: 07/03/18 09:30

## Lab Sample ID: 320-40847-6

Matrix: Solid

### Method: 8082A - Polychlorinated Biphenyls (PCBs) by Gas Chromatography

Analyte	Result	Qualifier	LOQ	DL	Unit	D	Prepared	Analyzed	Dil Fac
PCB-1016	10	U	34	3.5	ug/Kg		07/10/18 11:16	07/26/18 15:37	1
PCB-1221	15	U	34	5.3	ug/Kg		07/10/18 11:16	07/26/18 15:37	1
PCB-1232	21	U	34	6.6	ug/Kg		07/10/18 11:16	07/26/18 15:37	1
PCB-1242	21	U	34	7.6	ug/Kg		07/10/18 11:16	07/26/18 15:37	1
PCB-1248	15	U M	34	5.9	ug/Kg		07/10/18 11:16	07/26/18 15:37	1
PCB-1254	10	U M	34	2.8	ug/Kg		07/10/18 11:16	07/26/18 15:37	1
<b>PCB-1260</b>	<b>4.5</b>	<b>J</b>	34	3.0	ug/Kg		07/10/18 11:16	07/26/18 15:37	1

Surrogate	%Recovery	Qualifier	Limits	Prepared	Analyzed	Dil Fac
DCB Decachlorobiphenyl	77		60 - 125	07/10/18 11:16	07/26/18 15:37	1
DCB Decachlorobiphenyl	83		60 - 125	07/10/18 11:16	07/26/18 15:37	1

TestAmerica Sacramento

# Surrogate Summary

Client: Myounghee Noh & Associates  
Project/Site: KEKAHA, ISLAND OF KAUAI

TestAmerica Job ID: 320-40847-1

## Method: 8082A - Polychlorinated Biphenyls (PCBs) by Gas Chromatography

Matrix: Solid

Prep Type: Total/NA

### Percent Surrogate Recovery (Acceptance Limits)

Lab Sample ID	Client Sample ID	DCBP1 (60-125)	DCBP2 (60-125)
320-40847-1	DU1-MIS1	113	123
320-40847-1 MS	DU1-MIS1	91	
320-40847-1 MSD	DU1-MIS1	104	
320-40847-2	DU1-MIS2	80	85
320-40847-3	DU1-MIS3	88	90
320-40847-4	DU2-MIS1	71	75
320-40847-5	DU3-MIS1	78	82
320-40847-6	DU4-MIS1	77	83
320-40847-6 DU	DU4-MIS1	81	78
320-40847-6 TRL	DU4-MIS1	90	88
LCS 320-236318/2-A	Lab Control Sample	109	
MB 320-236318/1-A	Method Blank	96	89

#### Surrogate Legend

DCBP = DCB Decachlorobiphenyl



# QC Sample Results

Client: Myounghee Noh & Associates  
 Project/Site: KEKAHA, ISLAND OF KAUAI

TestAmerica Job ID: 320-40847-1

## Method: 8082A - Polychlorinated Biphenyls (PCBs) by Gas Chromatography

**Lab Sample ID: MB 320-236318/1-A**  
**Matrix: Solid**  
**Analysis Batch: 236295**

**Client Sample ID: Method Blank**  
**Prep Type: Total/NA**  
**Prep Batch: 236318**

Analyte	MB Result	MB Qualifier	LOQ	DL	Unit	D	Prepared	Analyzed	Dil Fac
PCB-1016	10	U	33	3.4	ug/Kg	-	07/10/18 11:16	07/26/18 11:52	1
PCB-1221	15	U	33	5.2	ug/Kg	-	07/10/18 11:16	07/26/18 11:52	1
PCB-1232	20	U	33	6.4	ug/Kg	-	07/10/18 11:16	07/26/18 11:52	1
PCB-1242	20	U	33	7.4	ug/Kg	-	07/10/18 11:16	07/26/18 11:52	1
PCB-1248	15	U	33	5.7	ug/Kg	-	07/10/18 11:16	07/26/18 11:52	1
PCB-1254	10	U	33	2.7	ug/Kg	-	07/10/18 11:16	07/26/18 11:52	1
PCB-1260	10	U	33	2.9	ug/Kg	-	07/10/18 11:16	07/26/18 11:52	1

Surrogate	MB %Recovery	MB Qualifier	Limits	Prepared	Analyzed	Dil Fac
DCB Decachlorobiphenyl	96		60 - 125	07/10/18 11:16	07/26/18 11:52	1
DCB Decachlorobiphenyl	89		60 - 125	07/10/18 11:16	07/26/18 11:52	1

**Lab Sample ID: LCS 320-236318/2-A**  
**Matrix: Solid**  
**Analysis Batch: 236295**

**Client Sample ID: Lab Control Sample**  
**Prep Type: Total/NA**  
**Prep Batch: 236318**

Analyte	Spike Added	LCS Result	LCS Qualifier	Unit	D	%Rec	Limits
PCB-1016	66.7	71.2		ug/Kg	-	107	47 - 134
PCB-1260	66.7	72.3		ug/Kg	-	109	53 - 140

Surrogate	LCS %Recovery	LCS Qualifier	Limits
DCB Decachlorobiphenyl	109		60 - 125

**Lab Sample ID: 320-40847-1 MS**  
**Matrix: Solid**  
**Analysis Batch: 236295**

**Client Sample ID: DU1-MIS1**  
**Prep Type: Total/NA**  
**Prep Batch: 236318**

Analyte	Sample Result	Sample Qualifier	Spike Added	MS Result	MS Qualifier	Unit	D	%Rec	Limits
PCB-1016	100	U M J1	68.0	98.9	J D J1	ug/Kg	-	146	47 - 134
PCB-1260	3000	D J1	68.0	755	D 4	ug/Kg	-	-3372	53 - 140

Surrogate	MS %Recovery	MS Qualifier	Limits
DCB Decachlorobiphenyl	91		60 - 125

**Lab Sample ID: 320-40847-1 MSD**  
**Matrix: Solid**  
**Analysis Batch: 236295**

**Client Sample ID: DU1-MIS1**  
**Prep Type: Total/NA**  
**Prep Batch: 236318**

Analyte	Sample Result	Sample Qualifier	Spike Added	MSD Result	MSD Qualifier	Unit	D	%Rec	Limits	RPD	RPD Limit
PCB-1016	100	U M J1	65.7	106	J D J1	ug/Kg	-	161	47 - 134	7	30
PCB-1260	3000	D J1	65.7	991	D 4	ug/Kg	-	-3129	53 - 140	27	30

Surrogate	MSD %Recovery	MSD Qualifier	Limits
DCB Decachlorobiphenyl	104		60 - 125

# QC Sample Results

Client: Myounghee Noh & Associates  
 Project/Site: KEKAHA, ISLAND OF KAUAI

TestAmerica Job ID: 320-40847-1

## Method: 8082A - Polychlorinated Biphenyls (PCBs) by Gas Chromatography (Continued)

**Lab Sample ID: 320-40847-6 DU**  
**Matrix: Solid**  
**Analysis Batch: 236295**

**Client Sample ID: DU4-MIS1**  
**Prep Type: Total/NA**  
**Prep Batch: 236318**

Analyte	Sample		DU		Unit	D	RPD	Limit
	Result	Qualifier	Result	Qualifier				
PCB-1016	10	U	9.9	U	ug/Kg		NC	30
PCB-1221	15	U	15	U	ug/Kg		NC	30
PCB-1232	21	U	20	U	ug/Kg		NC	
PCB-1242	21	U	20	U	ug/Kg		NC	
PCB-1248	15	U M	15	U M	ug/Kg		NC	
PCB-1254	10	U M	9.9	U M	ug/Kg		NC	
PCB-1260	4.5	J	4.37	J	ug/Kg		3	30
<b>DU DU</b>								
Surrogate	%Recovery	Qualifier	Limits					
DCB Decachlorobiphenyl	81		60 - 125					
DCB Decachlorobiphenyl	78		60 - 125					

**Lab Sample ID: 320-40847-6 TRL**  
**Matrix: Solid**  
**Analysis Batch: 236295**

**Client Sample ID: DU4-MIS1**  
**Prep Type: Total/NA**  
**Prep Batch: 236318**

Analyte	Sample		TRL		Unit	D	RSD	Limit
	Result	Qualifier	Result	Qualifier				
PCB-1016	10	U	9.7	U	ug/Kg		NC	20
PCB-1221	15	U	15	U	ug/Kg		NC	20
PCB-1232	21	U	19	U	ug/Kg		NC	20
PCB-1242	21	U	19	U	ug/Kg		NC	20
PCB-1248	15	U M	15	U M	ug/Kg		NC	20
PCB-1254	10	U M	9.7	U M	ug/Kg		NC	20
PCB-1260	4.5	J	5.80	J	ug/Kg		16	20
<b>TRL TRL</b>								
Surrogate	%Recovery	Qualifier	Limits					
DCB Decachlorobiphenyl	90		60 - 125					
DCB Decachlorobiphenyl	88		60 - 125					

# QC Association Summary

Client: Myounghee Noh & Associates  
 Project/Site: KEKAHA, ISLAND OF KAUAI

TestAmerica Job ID: 320-40847-1

## GC Semi VOA

### ISM Prep Batch: 232637

Lab Sample ID	Client Sample ID	Prep Type	Matrix	Method	Prep Batch
320-40847-1	DU1-MIS1	Total/NA	Solid	Increment, prep	
320-40847-2	DU1-MIS2	Total/NA	Solid	Increment, prep	
320-40847-3	DU1-MIS3	Total/NA	Solid	Increment, prep	
320-40847-4	DU2-MIS1	Total/NA	Solid	Increment, prep	
320-40847-5	DU3-MIS1	Total/NA	Solid	Increment, prep	
320-40847-6	DU4-MIS1	Total/NA	Solid	Increment, prep	
320-40847-1 MS	DU1-MIS1	Total/NA	Solid	Increment, prep	
320-40847-1 MSD	DU1-MIS1	Total/NA	Solid	Increment, prep	
320-40847-6 DU	DU4-MIS1	Total/NA	Solid	Increment, prep	
320-40847-6 TRL	DU4-MIS1	Total/NA	Solid	Increment, prep	

### Analysis Batch: 236295

Lab Sample ID	Client Sample ID	Prep Type	Matrix	Method	Prep Batch
320-40847-1	DU1-MIS1	Total/NA	Solid	8082A	236318
320-40847-2	DU1-MIS2	Total/NA	Solid	8082A	236318
320-40847-3	DU1-MIS3	Total/NA	Solid	8082A	236318
320-40847-4	DU2-MIS1	Total/NA	Solid	8082A	236318
320-40847-5	DU3-MIS1	Total/NA	Solid	8082A	236318
320-40847-6	DU4-MIS1	Total/NA	Solid	8082A	236318
MB 320-236318/1-A	Method Blank	Total/NA	Solid	8082A	236318
LCS 320-236318/2-A	Lab Control Sample	Total/NA	Solid	8082A	236318
320-40847-1 MS	DU1-MIS1	Total/NA	Solid	8082A	236318
320-40847-1 MSD	DU1-MIS1	Total/NA	Solid	8082A	236318
320-40847-6 DU	DU4-MIS1	Total/NA	Solid	8082A	236318
320-40847-6 TRL	DU4-MIS1	Total/NA	Solid	8082A	236318

### Prep Batch: 236318

Lab Sample ID	Client Sample ID	Prep Type	Matrix	Method	Prep Batch
320-40847-1	DU1-MIS1	Total/NA	Solid	3550B	232637
320-40847-2	DU1-MIS2	Total/NA	Solid	3550B	232637
320-40847-3	DU1-MIS3	Total/NA	Solid	3550B	232637
320-40847-4	DU2-MIS1	Total/NA	Solid	3550B	232637
320-40847-5	DU3-MIS1	Total/NA	Solid	3550B	232637
320-40847-6	DU4-MIS1	Total/NA	Solid	3550B	232637
MB 320-236318/1-A	Method Blank	Total/NA	Solid	3550B	
LCS 320-236318/2-A	Lab Control Sample	Total/NA	Solid	3550B	
320-40847-1 MS	DU1-MIS1	Total/NA	Solid	3550B	232637
320-40847-1 MSD	DU1-MIS1	Total/NA	Solid	3550B	232637
320-40847-6 DU	DU4-MIS1	Total/NA	Solid	3550B	232637
320-40847-6 TRL	DU4-MIS1	Total/NA	Solid	3550B	232637

# Lab Chronicle

Client: Myounghee Noh & Associates  
Project/Site: KEKAHA, ISLAND OF KAUAI

TestAmerica Job ID: 320-40847-1

## Client Sample ID: DU1-MIS1

Date Collected: 06/27/18 16:00

Date Received: 07/03/18 09:30

## Lab Sample ID: 320-40847-1

Matrix: Solid

Prep Type	Batch Type	Batch Method	Run	Dil Factor	Initial Amount	Final Amount	Batch Number	Prepared or Analyzed	Analyst	Lab
Total/NA	ISM Prep	Increment, prep					232637	07/05/18 22:03	AJC	TAL SAC
Total/NA	Prep	3550B			29.55 g	10 mL	236318	07/10/18 11:16	MSB	TAL SAC
Total/NA	Analysis	8082A		10			236295	07/26/18 12:33	RS1	TAL SAC

## Client Sample ID: DU1-MIS2

Date Collected: 06/27/18 16:00

Date Received: 07/03/18 09:30

## Lab Sample ID: 320-40847-2

Matrix: Solid

Prep Type	Batch Type	Batch Method	Run	Dil Factor	Initial Amount	Final Amount	Batch Number	Prepared or Analyzed	Analyst	Lab
Total/NA	ISM Prep	Increment, prep					232637	07/05/18 22:03	AJC	TAL SAC
Total/NA	Prep	3550B			30.35 g	10 mL	236318	07/10/18 11:16	MSB	TAL SAC
Total/NA	Analysis	8082A		5			236295	07/26/18 13:35	RS1	TAL SAC

## Client Sample ID: DU1-MIS3

Date Collected: 06/27/18 16:00

Date Received: 07/03/18 09:30

## Lab Sample ID: 320-40847-3

Matrix: Solid

Prep Type	Batch Type	Batch Method	Run	Dil Factor	Initial Amount	Final Amount	Batch Number	Prepared or Analyzed	Analyst	Lab
Total/NA	ISM Prep	Increment, prep					232637	07/05/18 22:03	AJC	TAL SAC
Total/NA	Prep	3550B			29.80 g	10 mL	236318	07/10/18 11:16	MSB	TAL SAC
Total/NA	Analysis	8082A		2			236295	07/26/18 13:55	RS1	TAL SAC

## Client Sample ID: DU2-MIS1

Date Collected: 06/28/18 10:30

Date Received: 07/03/18 09:30

## Lab Sample ID: 320-40847-4

Matrix: Solid

Prep Type	Batch Type	Batch Method	Run	Dil Factor	Initial Amount	Final Amount	Batch Number	Prepared or Analyzed	Analyst	Lab
Total/NA	ISM Prep	Increment, prep					232637	07/05/18 22:03	AJC	TAL SAC
Total/NA	Prep	3550B			30.45 g	10 mL	236318	07/10/18 11:16	MSB	TAL SAC
Total/NA	Analysis	8082A		1			236295	07/26/18 14:16	RS1	TAL SAC

## Client Sample ID: DU3-MIS1

Date Collected: 06/28/18 14:30

Date Received: 07/03/18 09:30

## Lab Sample ID: 320-40847-5

Matrix: Solid

Prep Type	Batch Type	Batch Method	Run	Dil Factor	Initial Amount	Final Amount	Batch Number	Prepared or Analyzed	Analyst	Lab
Total/NA	ISM Prep	Increment, prep					232637	07/05/18 22:03	AJC	TAL SAC
Total/NA	Prep	3550B			29.27 g	10 mL	236318	07/10/18 11:16	MSB	TAL SAC
Total/NA	Analysis	8082A		1			236295	07/26/18 14:36	RS1	TAL SAC

TestAmerica Sacramento

# Lab Chronicle

Client: Myounghee Noh & Associates  
Project/Site: KEKAHA, ISLAND OF KAUAI

TestAmerica Job ID: 320-40847-1

**Client Sample ID: DU4-MIS1**

**Lab Sample ID: 320-40847-6**

**Date Collected: 06/28/18 16:30**

**Matrix: Solid**

**Date Received: 07/03/18 09:30**

Prep Type	Batch Type	Batch Method	Run	Dil Factor	Initial Amount	Final Amount	Batch Number	Prepared or Analyzed	Analyst	Lab
Total/NA	ISM Prep	Increment, prep					232637	07/05/18 22:03	AJC	TAL SAC
Total/NA	Prep	3550B			29.21 g	10 mL	236318	07/10/18 11:16	MSB	TAL SAC
Total/NA	Analysis	8082A		1			236295	07/26/18 15:37	RS1	TAL SAC

**Laboratory References:**

TAL SAC = TestAmerica Sacramento, 880 Riverside Parkway, West Sacramento, CA 95605, TEL (916)373-5600

- 1
- 2
- 3
- 4
- 5
- 6
- 7
- 8
- 9
- 10
- 11
- 12
- 13
- 14
- 15

# Accreditation/Certification Summary

Client: Myounghee Noh & Associates  
 Project/Site: KEKAHA, ISLAND OF KAUAI

TestAmerica Job ID: 320-40847-1

## Laboratory: TestAmerica Sacramento

Unless otherwise noted, all analytes for this laboratory were covered under each accreditation/certification below.

Authority	Program	EPA Region	Identification Number	Expiration Date																																														
ANAB	DoD ELAP		L2468	01-20-21																																														
<table border="1" style="width: 100%; border-collapse: collapse;"> <thead> <tr> <th style="text-align: left;">Analysis Method</th> <th style="text-align: left;">Prep Method</th> <th style="text-align: left;">Matrix</th> <th style="text-align: left;">Analyte</th> </tr> </thead> <tbody> <tr> <td>USDA</td> <td>Federal</td> <td></td> <td>P330-11-00436</td> <td>01-17-21</td> </tr> <tr> <td colspan="5" style="padding: 5px 0 0 20px;">                     The following analytes are included in this report, but accreditation/certification is not offered by the governing authority:                 </td> </tr> <tr> <th style="text-align: left;">Analysis Method</th> <th style="text-align: left;">Prep Method</th> <th style="text-align: left;">Matrix</th> <th style="text-align: left;">Analyte</th> </tr> <tr> <td>8082A</td> <td>3550B</td> <td>Solid</td> <td>PCB-1016</td> </tr> <tr> <td>8082A</td> <td>3550B</td> <td>Solid</td> <td>PCB-1221</td> </tr> <tr> <td>8082A</td> <td>3550B</td> <td>Solid</td> <td>PCB-1232</td> </tr> <tr> <td>8082A</td> <td>3550B</td> <td>Solid</td> <td>PCB-1242</td> </tr> <tr> <td>8082A</td> <td>3550B</td> <td>Solid</td> <td>PCB-1248</td> </tr> <tr> <td>8082A</td> <td>3550B</td> <td>Solid</td> <td>PCB-1254</td> </tr> <tr> <td>8082A</td> <td>3550B</td> <td>Solid</td> <td>PCB-1260</td> </tr> </tbody> </table>					Analysis Method	Prep Method	Matrix	Analyte	USDA	Federal		P330-11-00436	01-17-21	The following analytes are included in this report, but accreditation/certification is not offered by the governing authority:					Analysis Method	Prep Method	Matrix	Analyte	8082A	3550B	Solid	PCB-1016	8082A	3550B	Solid	PCB-1221	8082A	3550B	Solid	PCB-1232	8082A	3550B	Solid	PCB-1242	8082A	3550B	Solid	PCB-1248	8082A	3550B	Solid	PCB-1254	8082A	3550B	Solid	PCB-1260
Analysis Method	Prep Method	Matrix	Analyte																																															
USDA	Federal		P330-11-00436	01-17-21																																														
The following analytes are included in this report, but accreditation/certification is not offered by the governing authority:																																																		
Analysis Method	Prep Method	Matrix	Analyte																																															
8082A	3550B	Solid	PCB-1016																																															
8082A	3550B	Solid	PCB-1221																																															
8082A	3550B	Solid	PCB-1232																																															
8082A	3550B	Solid	PCB-1242																																															
8082A	3550B	Solid	PCB-1248																																															
8082A	3550B	Solid	PCB-1254																																															
8082A	3550B	Solid	PCB-1260																																															

- 1
- 2
- 3
- 4
- 5
- 6
- 7
- 8
- 9
- 10
- 11
- 12
- 13
- 14
- 15

# Method Summary

Client: Myounghee Noh & Associates  
Project/Site: KEKAHA, ISLAND OF KAUAI

TestAmerica Job ID: 320-40847-1

Method	Method Description	Protocol	Laboratory
8082A	Polychlorinated Biphenyls (PCBs) by Gas Chromatography	SW846	TAL SAC
3550B	Ultrasonic Extraction	SW846	TAL SAC
Increment, prep	ISM - Dry, Disaggregate, Sieve, 2 D Slabcake Subsample	EPA	TAL SAC

#### Protocol References:

EPA = US Environmental Protection Agency

SW846 = "Test Methods For Evaluating Solid Waste, Physical/Chemical Methods", Third Edition, November 1986 And Its Updates.

#### Laboratory References:

TAL SAC = TestAmerica Sacramento, 880 Riverside Parkway, West Sacramento, CA 95605, TEL (916)373-5600



# Sample Summary

Client: Myounghee Noh & Associates  
Project/Site: KEKAHA, ISLAND OF KAUAI

TestAmerica Job ID: 320-40847-1

Lab Sample ID	Client Sample ID	Matrix	Collected	Received
320-40847-1	DU1-MIS1	Solid	06/27/18 16:00	07/03/18 09:30
320-40847-2	DU1-MIS2	Solid	06/27/18 16:00	07/03/18 09:30
320-40847-3	DU1-MIS3	Solid	06/27/18 16:00	07/03/18 09:30
320-40847-4	DU2-MIS1	Solid	06/28/18 10:30	07/03/18 09:30
320-40847-5	DU3-MIS1	Solid	06/28/18 14:30	07/03/18 09:30
320-40847-6	DU4-MIS1	Solid	06/28/18 16:30	07/03/18 09:30

- 1
- 2
- 3
- 4
- 5
- 6
- 7
- 8
- 9
- 10
- 11
- 12
- 13
- 14
- 15



West Sacramento, CA, 95605  
phone 916.373.5600 fax

Regulatory Program:  DW  NPDES  RCRA  Other: **TSCA PCB**

TestAmerica Laboratories, Inc.

**Client Contact**  
 Myounghee Noh & Associates, L.L.C.  
 99-1046 Iwaena St. Suite 210A  
 Aiea, HI, 96701  
 (808) 853-3137 Phone  
 (808) 484-4660 FAX  
 Project Name: KEKAHA 0.5 MG WATER TANK  
 Site: KEKAHA, ISLAND OF KAUAI  
 P.O.# 12388

**Project Manager:** Eunjin Kottkavetz  
**Tel/Fax:** eunjinn@noh-associates.com

**Analysis Turnaround Time**  
 CALENDAR DAYS  WORKING DAYS  
 TAT if different from Below: Standard \_\_\_\_\_  
 2 weeks  
 1 week  
 2 days  
 1 day

Sample Identification	Sample Date	Sample Time	Sample Type (C=Comp, G=Grab)	Matrix	# of Cont.	Filtered Sample (Y/N)		Perform MS / MSD (Y/N)		MIS Preparation (Hawaii Dept of H		PCB (6082)	Date:	Carrier:	COC No: 1 of 1 COCs
						Y	N	Y	N	Y	N				
DU1-MIS1	6/27/18	1600	MIS	soil	1	Y		Y		X					
DU1-MIS2	6/27/18	1600	MIS	soil	1	Y		X		X					
DU1-MIS3	6/27/18	1600	MIS	soil	1	Y		X		X					
DU2-MIS1	6/28/18	1030	MIS	soil	1	Y		X		X					
DU3-MIS1	6/28/18	1430	MIS	soil	1	Y		X		X					
DU4-MIS1	6/28/18	1630	MIS	soil	1	Y		X		X					



**Preservation Used:** 1= Ice, 2= HCl; 3= H2SO4; 4= HNO3; 5= NaOH; 6= Other \_\_\_\_\_

**Possible Hazard Identification:**  
 Are any samples from a listed EPA Hazardous Waste? Please List any EPA Waste Codes for the sample in the Comments Section if the lab is to dispose of the sample.  
 Non-Hazard  Flammable  Skin Irritant  Poison B  Unknown

**Sample Disposal (A fee may be assessed if samples are retained longer than 1 month)**  
 Return to Client  Disposal by Lab  Archive for \_\_\_\_\_ Months

**Special Instructions/QC Requirements & Comments:**  
 1.2<sup>u</sup> 1.2<sup>u</sup> 2.9<sup>u</sup> 2.9<sup>u</sup> ALK-2 ALK-2  
 Cooler Temp. (°C): Obs'd: \_\_\_\_\_ Therm ID No.: \_\_\_\_\_

**Custody Seal No.:** \_\_\_\_\_  
 Company: **MNA**  
 Relinquished by: **Eunjin Kottkavetz**  
 Date/Time: **07/05/18**

**Received by:** **John Alan**  
 Company: **HUSA**  
 Date/Time: **7/3/18 930**

**Relinquished by:** \_\_\_\_\_  
 Company: \_\_\_\_\_  
 Date/Time: \_\_\_\_\_

**Received in Laboratory by:** \_\_\_\_\_  
 Company: \_\_\_\_\_  
 Date/Time: \_\_\_\_\_



# Login Sample Receipt Checklist

Client: Myounghee Noh & Associates

Job Number: 320-40847-1

**Login Number: 40847**

**List Source: TestAmerica Sacramento**

**List Number: 1**

**Creator: Nelson, Kym D**

Question	Answer	Comment
Radioactivity wasn't checked or is </= background as measured by a survey meter.	True	
The cooler's custody seal, if present, is intact.	True	
Sample custody seals, if present, are intact.	N/A	
The cooler or samples do not appear to have been compromised or tampered with.	True	
Samples were received on ice.	True	GEL PACKS
Cooler Temperature is acceptable.	True	
Cooler Temperature is recorded.	True	
COC is present.	True	
COC is filled out in ink and legible.	True	
COC is filled out with all pertinent information.	True	
Is the Field Sampler's name present on COC?	False	
There are no discrepancies between the containers received and the COC.	True	
Samples are received within Holding Time (excluding tests with immediate HTs)	True	
Sample containers have legible labels.	True	
Containers are not broken or leaking.	True	
Sample collection date/times are provided.	True	
Appropriate sample containers are used.	True	
Sample bottles are completely filled.	True	
Sample Preservation Verified.	N/A	
There is sufficient vol. for all requested analyses, incl. any requested MS/MSDs	True	
Containers requiring zero headspace have no headspace or bubble is <6mm (1/4").	True	
Multiphasic samples are not present.	True	
Samples do not require splitting or compositing.	True	
Residual Chlorine Checked.	N/A	



**APPENDIX D. TIER 1 EAL SURFER SUMMARY REPORT**

# <sup>1</sup>Tier 1 EAL SURFER SUMMARY REPORT

## Hawai'i DOH (Fall 2017)

**Site Name:** KEKAHA WATER SYSTEM, KEKAHA, ISLAND OF KAUAI 96752  
**Site Address:** TMK (4) 1-2-002:039

**Site ID Number:**  
**Date of EAL Search:** 16-Aug-18

Selected Site Scenario	
<b>Land Use:</b>	Unrestricted
<b>Groundwater Utility:</b>	Drinking Water Resource
<b>Distance To Nearest Surface Water Body:</b>	< 150m

**Selected Chemical of Concern:** POLYCHLORINATED BIPHENYLS (PCBs)

Input Site Concentrations	
Soil (mg/kg):	6.35
Groundwater (ug/L):	-
Soil Vapor (ug/m <sup>3</sup> ):	-

Soil Environmental Hazards	Units	Tier 1 Action Level	<sup>2</sup> Potential Hazard?	<sup>3</sup> Referenced Table
<b>Direct Exposure:</b>	mg/kg	1.2E+00	Yes	Table I-1
<b>Vapor Emissions To Indoor Air:</b>	mg/kg	-	-	Table C-1b
<b>Terrestrial Ecotoxicity:</b>	mg/kg	site-specific	No	Table L
<b>Gross Contamination:</b>	mg/kg	5.0E+02	No	Table F-2
<b>Leaching (threat to groundwater):</b>	mg/kg	3.4E+01	No	Table E-1
<b>Background:</b>	mg/kg	-		
<b>Final Soil Tier 1 EAL:</b>		<b>mg/kg 1.2E+00</b>		
<b>Basis: Direct Exposure</b>				

Groundwater Environmental Hazards	Units	Tier 1 Action Level	<sup>2</sup> Potential Hazard?	<sup>3</sup> Referenced Table
<b>Drinking Water (Toxicity):</b>	ug/L	5.0E-01	-	Table D-1a
<b>Vapor Emissions To Indoor Air:</b>	ug/L	-	-	Table C-1a
<b>Aquatic Ecotoxicity:</b>	ug/L	1.4E-02	-	Table D-4a
<b>Gross Contamination:</b>	ug/L	2.2E+01	-	Table G-1
<b>Final Groundwater Tier 1 EAL:</b>		<b>ug/L 1.4E-02</b>		
<b>Basis: Aquatic Ecotoxicity</b>				

Other Tier 1 EALs:	Units	EAL	<sup>2</sup> Potential Hazard?	<sup>3</sup> Referenced Table
<b>Shallow Soil Vapor:</b>	ug/m <sup>3</sup>	9.9E+01	-	Table C-2
<b>Indoor Air:</b>	ug/m <sup>3</sup>	4.9E-02	-	Table C-3

**Notes:**

1. Include Surfer Summary Report in appendices of *Environmental Hazard Evaluation* (EHE) for contaminants that exceed Tier 1 EALs (refer to Chapter 3 of main text).
2. Environmental hazard could exist if concentration of contaminant exceeds action level.
3. Referenced tables presented in Appendix 1 of EHE guidance document.

HDOH 2017, Evaluation of Environmental Hazards at Sites with Contaminated Soil and Groundwater (Fall 2017): Hawai'i Department of Health, Hazard Evaluation and Emergency Response, <http://hawaii.gov/health/environmental/hazard/index.html>



# LETTER OF TRANSMITTAL

4398 PUA LOKE STREET  
LĪHU‘E, KAUA‘I, HAWAI‘I 96766  
PHONE: 808-245-5400 / FAX: 808-245-5813

DATE: October 25, 2018

TO: Mr. Jerry Fujita KAI Hawai‘i, Inc. 50 South Beretania Street, #C-119C Honolūlū, HI 96813	JOB #: 17-10, WP2020 #KW-07 RE: Rehabilitate Paua Valley Tank #1, 0.5mg Concrete Kekaha Water System, Kekaha, Kaua‘i, Hawai‘i
---	---

We are sending you the following items:

COPIES	DESCRIPTION
1 EA	Certification Statement for e-Permitting Submission #HNN-RE2M-VNM3V, version 2

These are transmitted as checked below:

- |                                     |                            |                          |  |
|-------------------------------------|----------------------------|--------------------------|--|
| <input type="checkbox"/>            | For signature              | <input type="checkbox"/> | Approved as submitted                  |
| <input type="checkbox"/>            | For review and comment     | <input type="checkbox"/> | As requested                           |
| <input type="checkbox"/>            | For your use               | <input type="checkbox"/> | Returned for corrections               |
| <input checked="" type="checkbox"/> | Other (see comments below) | <input type="checkbox"/> | Return revision with DOW red-lined set |

Aloha Mr. Fujita:

Enclosed is the above referenced document for processing. If you have any questions, please call Eric Fujikawa at (808) 245-5412 or email [efujikawa@kauaiwater.org](mailto:efujikawa@kauaiwater.org).

Mahalo.

COPIES TO: FILE, ENG

SIGNED:

  
 Christine Ererita, Deputy Secretary

*If enclosures are not as noted, kindly notify us at once.*



## TRANSMITTAL REQUIREMENTS AND CERTIFICATION STATEMENT FOR E-PERMITTING NOTICE OF INTENT (NOI) SUBMISSIONS

### 1. Submission and File Numbers

e-Permitting Submission #: HNH-RE2M-VNM3V, version 2

I am submitting a (check only one):

Initial NOI.

Revised NOI, File Number: \_\_\_\_\_

NOI for an Already Issued NGPC, Current NGPC File Number: \_\_\_\_\_

### 2. Certification Statement

I certify under penalty of law that this document and all attachments were prepared under my direction or supervision in accordance with a system designed to assure that qualified personnel properly gather and evaluate the information submitted. Based on my inquiry of the person or persons who manage the system, or those persons directly responsible for gathering the information, the information submitted is, to the best of my knowledge and belief, true, accurate, and complete. I am aware that there are significant penalties for submitting false information, including the possibility of fine and imprisonment for knowing violations.

Signature *Bryan Wienand* Date Signed 10/24/18

Printed First and Last Name Bryan Wienand

### 3. Transmittal Requirements (Check all.)

I have read the instructions on Pages 2 and 3.

If I do not follow all of the instructions on Pages 2 and 3, I acknowledge that:

- This submittal will not be accepted by the Clean Water Branch (CWB);
- Processing of my NOI will not begin;
- I am delaying the processing of my NOI; and
- The CWB may deny my request for NPDES general permit coverage with or without prejudice.

The signature provided in Item No. 2 is an original signature.

My CD or DVD is attached. This CD or DVD contains only the downloaded e-Permitting submission identified in Item No. 1 above. I have not altered this file.

### 4. Filing Fee (Check the applicable box.)

A \$500 check made payable to the State of Hawaii is attached.

The filing fee was paid online through the e-Permitting Portal.

I am submitting a Revised NOI. My filing fee has already been paid under the initial submittal.

I am a State agency, and I am requesting a Bill for Collection.

## **IMPORTANT INSTRUCTIONS:**

You are required to follow these instructions to complete your e-Permitting NOI submittal. Failure to follow all of these instructions will delay the processing of your submittal and may result in the denial of your request for NPDES general permit coverage. **Processing of your submission will not begin until the Clean Water Branch (CWB) receives all of the items below.**

### Item No. 1 – Submission and File Numbers

- a. Enter your e-Permitting Submission #. You may find your unique e-Permitting Submission # (e.g. 15H-ZGVV-421H) in your History Link of the e-Permitting Portal. If you are submitting a revised NOI, the e-Permitting Submission # will contain the version (e.g. 15H-ZGVV-421H, v1).
- b. Check only one (1) box to indicate if you are submitting an Initial NOI (new submittal) or a Revised NOI (revised submittal to address CWB comments) or a NOI for an Already Issued NGPC (see Item No. 1.d below).
- c. Enter your file number if you are revising an Initial NOI to respond to CWB comments. The CWB comments will contain the file number. You will not need to provide a file number if you are submitting an Initial NOI.
- d. Enter your current NGPC file number if you are submitting a NOI for an Already Issued NGPC. A NOI for an Already Issued NGPC is required if there are any changes to the information previously provided. NGPCs can no longer be modified and reissued. Once the NGPC is issued, any changes to the information provided during the NOI processing (except changes to BMPs) will require another NOI with filing fee and another NGPC to be issued. Upon issuance of the NGPC, the existing NGPC will be terminated.

### Item No. 2 – Certification Statement

- a. This is the certification statement for the e-Permitting submission # identified in Item No. 1.
- b. Enter the Printed First and Last Name.
  - i. For an Initial NOI and a NOI for an Already Issued NGPC, the Printed First and Last Name must be the Certifying Person identified in Section No. 2 of the e-Permitting NOI form.
  - ii. For Revised NOI submittals, the Printed First and Last Name may be either the Certifying Person identified in Section No. 2 of the e-Permitting NOI form or the duly authorized representative identified in Section No. 8 of the e-Permitting NOI form.
- c. Enter the Date Signed.
- d. Provide an original Certification signature (hard copy of this form).  
Someone else may sign "for" the individual listed in the Printed First and Last Name.

### Item No. 3 – Transmittal Requirements

- a. You are required to check all of the boxes.
- b. Provide a **CD or DVD containing only the e-Permitting submission in PDF or ZIP**. To download the submission, click on the History Link in the e-Permitting Portal (after you submitted the application). Locate your submission and press the view button under the Action column. Then you may either:
  - i. Press the Print button, scan the document, save the document as a PDF, and save the PDF and all your attachments on the CD or DVD; or
  - ii. Press the Print Screen button on your keyboard, paste the image into a text editor (e.g. MS Word), convert the text file as a PDF, and save the PDF and all your attachments on the CD or DVD; or
  - iii. **Press the Download Submission button**. A PDF file will be generated if you have no attachments. **A ZIP file will be created if you have attachments. Save the PDF or ZIP file on the CD or DVD.****Do not add additional files to the CD or DVD. Your CD or DVD shall match your e-Permitting submission #.**

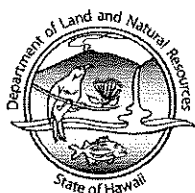
### Item No. 4 – Filing Fee

- a. You are required to check only one (1) of the boxes.
- b. A \$500 filing fee is required for an Initial NOI and a NOI for an Already Issued NGPC.
- c. If you are a State agency, you may request a Bill for Collection.

### Additional

- a. Mail or deliver this form and all attachments to the Department of Health, Clean Water Branch, Hale Ola Building, 2827 Waimano Home Road, Room 225, Pearl City, Hawaii 96782.

DAVID Y. IGE  
GOVERNOR OF HAWAII



STATE OF HAWAII  
DEPARTMENT OF LAND AND NATURAL RESOURCES

STATE HISTORIC PRESERVATION DIVISION  
KAKUHIHEWA BUILDING  
601 KAMOKILA BLVD, STE 555  
KAPOLEI, HAWAII 96707

SUZANNE D. CASE  
CHAIRPERSON  
BOARD OF LAND AND NATURAL RESOURCES  
COMMISSION ON WATER RESOURCE MANAGEMENT

ROBERT K. MASUDA  
FIRST DEPUTY

JEFFREY T. PEARSON, P.E.  
DEPUTY DIRECTOR - WATER

AQUATIC RESOURCES  
BOATING AND OCEAN RECREATION  
BUREAU OF CONVEYANCES  
COMMISSION ON WATER RESOURCE MANAGEMENT  
CONSERVATION AND COASTAL LANDS  
CONSERVATION AND RESOURCES ENFORCEMENT  
ENGINEERING  
FORESTRY AND WILDLIFE  
HISTORIC PRESERVATION  
KAHOOLAWE ISLAND RESERVE COMMISSION  
LAND  
STATE PARKS

July 31, 2018

Eric Fujikawa  
Department of Water, County of Kauai  
4398 Pua Loke Street  
Lihue, Hawaii 96766  
[efujikawai@kauaiwater.org](mailto:efujikawai@kauaiwater.org)

IN REPLY REFER TO:  
Log No. 2018.01359  
Doc No. 1807GC23  
Archaeology

Dear Mr. Fujikawa:

**SUBJECT: Chapter 6E-8 Historic Preservation Review –  
Request for Concurrence of No Historic Properties Affected  
Rehabilitation of Paua Valley Tank No. 1, 0.5 MG Concrete Kekaha Water System  
Kekaha Ahupua‘a, Kona District, Island of Kana‘i  
TMK: (4) 1-2-002: 039**

This letter provides the State Historic Preservation Division's (SHPD's) review of the subject County of Kauai Department of Water (DOW) project identified as *Rehabilitation of Paua Valley Tank No. 1, 0.5 MG Concrete Kekaha Water System* project. Per the submittal, DOW requests the SHPD's concurrence with their HRS 6E project effect determination of no historic properties affected. The SHPD received this submittal on June 25, 2018. The submittal included a DOW cover letter, a HRS 6E Submittal Form, site plans, a TMK plat map, and photographs. The scope of work includes the repair and rehabilitation of the existing concrete water tank, removal of existing AC pavement, and installation of new AC pavement around the water tank, within the 0.648-acre State-owned parcel.

The water system and the storage tank are less than 50 years old and do not meet the HRS 6E-2 definition of a historic property. Additionally, a review of SHPD records indicate that no archaeological inventory survey has been conducted for the subject parcel and that no historic properties have been identified. The USDA identifies the soils as Kekaha extremely stony, silty clay (KOYE) (Foote et al. 1972)

Based on the information provided, the SHPD concurs with DOW's HRS 6E effect determination of *no historic properties affected*. Pursuant to HAR §13-275-8(e) "When the SHPD agrees that the action will not affect any significant historic properties, this is the SHPD's written concurrence and historic preservation review ends". The historic preservation review process is ended. The permitting process may continue.

Attach to the permit: In the event that historic properties, including human skeletal remains, structural remains, cultural deposits or features, or artifacts are uncovered please cease work in the vicinity of the find, protect the find from further disturbance, and immediately contact the State Historic Preservation Division at (808) 692-8015.

Please contact Dr. Susan Lebo, Archaeology Branch Chief, at (808) 692-8019 or at [Susan.A.Lebo@hawaii.gov](mailto:Susan.A.Lebo@hawaii.gov) if you have any questions regarding this letter.

Aloha,  
*Alan Downer*

Alan S. Downer, PhD  
Administrator, State Historic Preservation Division  
Deputy Historic Preservation Officer

cc: Jerry Fujita, KAI Hawaii, [jfujita@kaihawaii.com](mailto:jfujita@kaihawaii.com)  
Chance Bukoski, County of Kauai, [cbukoski@kauai.gov](mailto:cbukoski@kauai.gov)





# **Water Quality Report**

Covering the period of  
January 1, 2017 to December 31, 2017

**Department of**



**County of Kaua'i**

Kaua'i Department of Water  
Kekaha-Waimea Water System  
2018

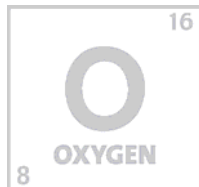
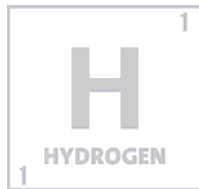


This report by the Kaua'i Department of Water describes the quality of your drinking water, and where it comes from. The Safe Drinking Water Act, a federal law, requires water utilities to provide water quality information to its customers every year.

Providing safe drinking water is a complex business, but you and your neighbors have a right to know the results of our water quality monitoring. Safe drinking water is essential to our community. Your water is tested regularly through our certified laboratories and the State Department of Health.

In summary, our drinking water meets, or is better than, state and federal standards. We spend in excess of \$400,000 in chemical and microbial testing each year to assure the safety of your water.

A Source Water Assessment, intended to enable "well-founded, fair and reasonable decisions for the protection and preservation of Hawai'i's drinking water" has been completed by the State Department of Health and the University of Hawai'i. For Further information on this assessment, please contact the Department of Water at (808) 245-5455.



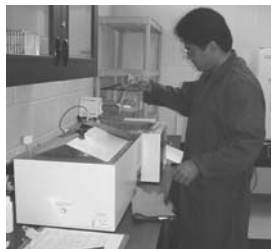
We welcome your interest in the Department of Water's water system. Please refer to the directory in this publication for the Department's phone numbers. Also, the Water Board normally meets on the fourth Friday of each month, and their meetings are open to the public. Please call (808) 245-5406 for the time, date and location.

Beth Tokioka  
***Chairperson, Board of Water Supply***

Bryan Wienand, P.E.  
***Manager and Chief Engineer***

## Why am I getting this brochure?

The Safe Drinking Water Act has been amended to require water systems to provide its customers with an annual report of the quality of their drinking water. This brochure is a snapshot of the quality of the water we provided last year. Included are details about where your water comes from, what it contains and how it compares to Environmental Protection Agency (EPA) and state standards.



We are committed to providing you with information because informed customers are our best allies.

## Is my drinking water safe?

**Yes.** The Department of Water regularly conducts microbiological analysis and has contracted for extensive chemical testing in order to comply with Environmental Protection Agency (EPA) and Hawai'i State standards. The standards are very strict in order to ensure safe drinking water.

## Where does my water come from?

Your water comes from ground water (**underground**) sources. Rain that falls in the mountain filters through the ground into formations called aquifers. Wells are drilled into these formations and the water is pumped out. These formations can also be found in the mountains (**still considered ground water**). Tunnels are constructed to tap these sources. The quality of groundwater is very good and requires no treatment except for disinfection (**as opposed to surface water sources that require filtration and stronger disinfection**).

The water supply for the Kekaha-Waimea Water System water system comes from the following sources:

***Kekaha, Waipa'o Valley Well***

***Waimea Well A***

***Kekaha, Pau'a Valley Well***

***Waimea Well B***

***Kekaha Shaft 12***

***Kapilimao Well***

All of the water is chlorinated and pumped into the distribution system or stored in the following tanks:

***Kapilimao  
500,000 gallon tank***

***Waimea  
100,000 gallon tank***

***Kekaha  
500,000 gallon tanks @ 2 each***

***Waimea  
200,000 gallon tank***

***Waimea - 500,000 gallon tank***

## How do contaminants get into our drinking water?

The sources of drinking water (*both tap water and bottled water*) include rivers, lakes, streams, ponds, reservoirs, springs and wells.

As water travels over the surface of the land or through the ground, it dissolves naturally occurring minerals and, in some cases, radioactive material, and can pick up substances resulting from the presence of animals or from human activity.

Therefore, drinking water, including bottled water may reasonably be expected to contain at least small amounts of some contaminants. The presence of contaminants does not necessarily indicate that the water poses a health risk.

Contaminants that may be present in source water before we treat it include:

**Microbial contaminants:** Viruses and bacteria from sewage treatment plants, septic systems, agricultural livestock operations and wildlife.

**Inorganic contaminants:** Salts and metals which can be naturally occurring or from other sources, such as urban storm water runoff, industrial or domestic wastewater discharges, oil and gas production, mining or farming.

**Pesticides and herbicides:** Variety of sources such as agriculture, urban storm water runoff and residential uses.

**Radioactive contaminants:** Naturally occurring.

**Organic chemical contaminants:** Synthetic and volatile organic chemicals, by-products of industrial processes and petroleum production, also from gas stations, urban storm water runoff, and septic systems.

To ensure safe tap water, EPA sets limits on these substances in water provided by public water systems.



## Should I take special precautions?

Some people may be more vulnerable to contaminants in drinking water than the general population. Immuno-compromised persons such as persons with cancer undergoing chemotherapy, persons who have undergone organ transplants, people with HIV/AIDS or other immune system disorders, some elderly and infants can be particularly at risk from infections. These people should seek advice about drinking water from their healthcare providers.

EPA/CDC (Centers for Disease Control) guidelines on appropriate means to lessen the risk of infection by *Cryptosporidium* and other microbial contaminants are available from EPA's Safe Drinking Water Hotline (1-800-426-4791).

More information about contaminants can also be obtained by calling the EPA's Hotline.

## Other Frequently Asked Questions:

### ***What is the pH of my water?***

The pH of your water in the Kekaha-Waimea area can range from 7.4 to 7.8.

### ***What is the hardness of my water?***

The hardness of your water can range from 60 to 190 ppm.

### ***Why do I notice off-odors or taste in my water?***

Sometimes if water in your house is not used, the microbes in the pipes can grow and cause odors and funny taste. Flushing the water can resolve this problem. Water should be flushed in the morning or when not used for an extended period of time.

### ***What causes my water to look milky when it comes out of the faucet?***

Air trapped in the water lines causes this problem. Let the water sit in a glass. The water becomes clear from the bottom up if air is the cause. The water is safe to drink.

### ***Why is chlorine added to my water?***

Chlorine is added to control microbe levels in the water distribution system to keep the water safe. The chlorine level ranges between 0.1 to 0.5 ppm. The small amounts of chlorine in the water do not pose a health hazard. If you want to remove chlorine, either let it sit for a while or filter it through an activated carbon filter.



## Water Quality Data

We are required to test your tap water for:

- Different types of chemical contaminants: Regulated contaminants, each with a maximum contaminant level (MCL) and a maximum contaminant level goal (MCLG); and unregulated contaminants, which don't have maximum contaminant levels.
- Coliform bacteria.
- Heavy metals (lead and copper).

Remember that just because these contaminants may be present in your water, it doesn't mean your water has a health risk.

This past year, we tested your water for a wide array of contaminants. Most of them were not found in your water, and only those that we found are reported in the test results section that follows.



**Microbiological Contaminants**

Total Coliform Bacteria  
Fecal Coliform Bacteria

**Radioactive Contaminants**

Alpha emitters  
Beta/photon emitters  
Radium

**Inorganic Contaminants**

Antimony  
Arsenic  
Asbestos  
Barium  
Beryllium  
Cadmium  
Chromium  
Copper  
Cyanide  
Fluoride  
Lead  
Mercury  
Nitrate  
Nitrite  
Selenium  
Thallium

**Organic Contaminants**

2,4-D  
2,4,5-TP[Silvex]  
Acrylamide  
Alachlor  
Atrazine  
Benzo(a)pyrene  
Carbofuran  
Chlordane  
Dalapon  
Di(2-ethylhexyl) adipate  
Di(2-ethylhexyl) phthalate  
Dibromochloropropane  
Dinoseb  
Diquat  
Dioxin  
Endothall  
Endrin  
Epichlorohydrin  
Ethylene dibromide  
Glyphosate  
Heptachlor  
Heptachlor epoxide  
Hexachlorobenzene  
Hexachlorocyclopentadiene  
Lindane  
Methoxychlor  
Oxamyl [Vydate]  
PCBs [Polychlorinated biphenyls]  
Pentachlorophenol  
Picloram  
Simazine  
Toxaphene

**Volatile Organic Contaminants**

Benzene  
Carbon tetrachloride  
Chlorobenzene  
o-Dichlorobenzene  
p-Dichlorobenzene  
1,2-Dichloroethane  
1,1-Dichloroethylene  
Cis-1,2-Dichloroethylene  
trans-1,2-Dichloroethylene  
Dichloromethane  
1,2-Dichloropropane  
Ethylbenzene  
HAA (Haloacetic Acid)  
Styrene  
Tetrachloroethylene  
1,2,4-Trichlorobenzene  
1,1,1-Trichloroethane  
1,1,2-Trichloroethane  
Trichloroethylene  
1,2,3-Trichloropropane  
TTHMs [Total trihalomethanes]  
Toluene  
Vinyl Chloride  
Xylenes

**Unregulated Contaminants**

2,4,5-T  
2-4-DB  
Aldicarb  
Aldicarb sulfone  
Aldicarb sulfoxide  
Aldrin  
Butachlor  
Carbaryl  
Dicamba  
Dieldrin  
3-Hydroxycarbofuran  
Methiocarb  
Methomyl  
Metolachlor  
Metribuzin  
Molinate  
Nickel  
Paraquat  
Propachlor  
Propoxur  
Thiobencarb



**Results:**

The following tables list all the drinking water contaminants that were found in 2017. Unless otherwise noted, the data presented in the following tables are from testing done January 1 - December 31, 2017.

The State requires us to monitor for certain contaminants less than once per year because the concentrations of these contaminants are not expected to vary from year to year. Thus, some of the data, though representative of the water quality, is more than one year old.

This Consumer Confidence Report (CCR) reflects changes in drinking water regulatory requirements during 2016. All water systems were required to comply with the Total Coliform Rule from 1989 to March 31, 2016, and began compliance with a new rule, the Revised Total Coliform Rule on April 1, 2016. The new rule maintains the purpose to protect public health by ensuring the integrity of the drinking water distribution system and monitoring for the presence of microbial (i.e. total coliform and E. coli bacteria). The U.S. EPA anticipates greater public health protection under this new rule, as it required water systems that are vulnerable to microbial contamination to identify and fix problems. As a result, under the new rule there is no longer a monthly maximum contamination level violation for multiple total coliform detections. Instead, the new rule requires water systems that exceeds a specified frequency of total coliform occurrences to conduct an assessment to determine if any sanitary defects exist. If found, these must be corrected by the public water system.

## **Terms and abbreviations used below:**

**Maximum Contaminant Level Goal (MCLG):** is the level of contaminant in drinking water below which there is no known or expected risk to health. MCLGs allow for a margin of safety.

**Maximum Contaminant Level (MCL):** the highest level of a contaminant that is allowed in drinking water. MCLs are set as close to the MCLGs as feasible using the best available treatment technology.

**Action Level (AL):** the concentration of a contaminant which, when exceeded, triggers treatment or other requirements which a water system must follow.

n/a: not applicable.

nd: not detectable at testing limit.

ppm: parts per million or milligrams per liter  
(corresponds to one penny in \$10,000).

ppb: parts per billion or micrograms per liter  
(corresponds to one penny in \$10,000,000).

pCi/L: picocuries per liter  
(a measure of radiation).

mrem/year: millirems per year  
(a measure of radiation exposure).



### Microbiological Contaminants:

Substance	Highest Level Allowed (MCL)	EPA MCLG	Highest Monthly # of Positive Samples	Date	Violation	Source of Contaminant
None Detected						

### Inorganic Contaminants:

Substance	Highest Level Allowed (MCL)	EPA MCLG	Highest Level Detected	Detection Range	Date	Violation	Source of Contaminant
Chromium (ppb)	100	100	10	3-10	2016	No	Erosion of Natural Deposits
Nitrate (ppm)	10	10	3	2-3	2016	No	Runoff from fertilizer use; leaching from septic tanks, sewage; erosion of natural deposits

### Organic Contaminants:

Substance	Highest Level Allowed (MCL)	EPA MCLG	Highest Level Detected	Detection Range	Date	Violation	Source of Contaminant
TTHMs (Total trihalomethanes) (ppb)	80	NA	3	-	2017	No	By-Product of drinking water chlorination

### Lead and Copper Rule Compliance:

Substance	Action Level	EPA MCLG	90th Percentile Value	Detection Range	# of Sites Found Above AL	Date	Source of Contaminant
Lead (ppb)	15	0	<5	ND-8	0/20	2015	Corrosion of household plumbing systems
Copper (ppm)	1.3	1.3	0.06	ND-0.16	0/20	2015	Corrosion of household plumbing Systems

The Kekaha-Waimea system is in compliance with the Lead and Copper Rule Requirements and is on a reduced monitoring schedule. Samples for lead and copper will be taken and analyzed every three years from residential customers.

### Unregulated Contaminants:

Substance	Highest Level Allowed (MCL)	EPA MCLG	Highest Level Detected	Detection Range	Date	Violation	Source of Contaminant
None Detected							

### Radioactive Contaminants:

Substance	Highest Level Allowed (MCL)	EPA MCLG	Highest Level Detected	Detection Range	Date	Violation	Source of Contaminant
Beta Emitters (pCi/L)	-	0	4	ND-4	2016	No	Erosion of Natural Deposits
Alpha Emitters (pCi/L)	15	0	13	ND-13	2016	No	Erosion of Natural Deposits

If present, elevated levels of lead can cause serious health problems, especially for pregnant women and young children. Lead in drinking water is primarily from materials and components associated with service lines and home plumbing. The Department of Water is responsible for providing high quality drinking water, but cannot control the variety of materials used in plumbing components. When your water has been sitting for several hours, you can minimize the potential for lead exposure by flushing your tap for 30 seconds to 2 minutes before using water for drinking or cooking. If you are concerned about lead in your water, you may wish to have your water tested. Information on lead in drinking water, testing methods, and steps you can take to minimize exposure is available from the Safe Drinking Water Hotline or at <http://www.epa.gov/safewater/lead>.



## Where to call

<b>Who</b>	<b>About</b>	<b>Number</b>
Kaua'i Dept. of Water	General Inquiries Water Quality Report	(808) 245-5400
State Dept. of Health	Contaminants, health effects	(808) 586-4258
EPA Safe Drinking Water Hotline	Contaminants, health effects	1-800-426-4791